



TECHNICAL DOCUMENTATION

ROBOT S7



 Norm. Tecn. 60.2.109 rev. 00	TECHNICAL DOCUMENTATION ROBOT S7	March 2022	Rev.07
	ENGLISH	Pag. 2 / 93	

Date	Revision	Detailed revision reasons	Issue-Checked by
06/2021	00	First issue	<i>Fabrizio BALDININI</i>
07/2021	01	Modification of parameters, modification of software insertion procedure in the Touch and in the carriage PLC	<i>Fabrizio BALDININI</i>
09/2021	02	Details on the software update operation	<i>Fabrizio BALDININI</i>
10/2021	03	Modification of parameter nomenclature and addition of P8	<i>Fabrizio BALDININI</i>
12/2021	04	New general parameters saving mode (P)	<i>Fabrizio BALDININI</i>
02/2022	05	Enter parameters C14, C15, delete parameters P6, P8, enter film tension delay parameter	<i>Fabrizio BALDININI</i>
03/2022	06	"Recovery" charging curve insertion	<i>Fabrizio BALDININI</i>
03/2022	07	Roping calibration procedure and new alarms	<i>Fabrizio BALDININI</i>

 Norm. Tecn. 60.2.109 rev. 00	TECHNICAL DOCUMENTATION ROBOT S7	March 2022	Rev.07
	ENGLISH	Pag. 3 / 93	

Index

CARRIAGES SCHEMATIC DESCRIPTION and FILM PATH	7
FRD CARRIAGE.....	7
FR CARRIAGE.....	8
FILM PATH in FRD and FR carriages	9
P3GS CARRIAGE	10
PVS CARRIAGE	11
FILM PATH in P3GS and PVS carriages	12
OPERATOR PANEL DESCRIPTION.....	13
BATTERY STATE DESCRIPTION.....	14
CYCLE PARAMETERS DESCRIPTION	15

 Norm. Tecn. 60.2.109 rev. 00	TECHNICAL DOCUMENTATION ROBOT S7	March 2022	Rev.07
	ENGLISH	Pag. 4 / 93	

QUICK MENU21

PASSWORDS MANAGEMENT22

 Password for VISION SERVICE area23

 RESET of the Customer Manager password to 1111.....24

MANUAL OPERATIONS ON THE CARRIAGE25

MANUAL OPERATIONS ON THE STEERING WHEEL26

 FAST FORWARD in Manual.....26

CIRCULAR LED MEANING.....27

CYCLE SELECTION.....28

SERVICE PAGES29

COUNTERS.....30

VARIOUS SETTINGS AND INFORMATION31

SERVICE PAGES32

CONFIGURATION PARAMETERS33

 ACCESS to CONFIGURATION PARAMETERS34

 CONFIGURATION PARAMETERS DEFAULT35

 LIST of the CONFIGURATION PARAMETERS until March 202236

 LIST of the CONFIGURATION PARAMETERS from March 2022.....37

 ACCESS to CARRIAGE PARAMETERS38

 DEFAULT of the CARRIAGE PARAMETERS.....39

 LIST of the CARRIAGE PARAMETERS40

 ACCESS to MOTOR PARAMETERS41

 MOTOR PARAMETERS DEFAULT42

 LIST of the MOTOR PARAMETERS43

 Norm. Tecn. 60.2.109 rev. 00	TECHNICAL DOCUMENTATION ROBOT S7	March 2022	Rev.07
	ENGLISH	Pag. 5 / 93	

LOAD CELL CALIBRATION44

VARIABLE ROPING CALIBRATION/SETTING.....45

CARRIAGE TEST CYCLE.....45

COMUNICATION CHECK between DEVICES.....47

R-CONNECT MODULE REGISTRATION.....48

PRODUCT HEIGHT DETECTION PHOTOCELL CALIBRATION49

 STANDARD PHOTOCELL (for clear products).....49

 PHOTOCELL FOR BLACK PRODUCTS S6249

 READING DISTANCE ADJUSTMENT50

 PHOTOCELL FOR BLACK PRODUCTS S6551

“POWER SAVE” FUNCTION52

AUTO POWER OFF FUNCTION52

LITHIUM BATTERY AUTO POER OFF.....52

BATTERY CHARGER SETTINGS53

 CHECK THE CURRENT DELIVERED in the CHARGE PHASE54

 MEANING OF THE LEDS of the battery charger54

BATTERYCHARGERS ALARMS55

“RECOVERY” CHARGING CURVE.....56

 Norm. Tecn. 60.2.109 rev. 00	TECHNICAL DOCUMENTATION ROBOT S7	March 2022	Rev.07
	ENGLISH	Pag. 6 / 93	

PROCEDURES FOR REPLACEMENT, SOFTWARE LOADING AND CALIBRATION OF ELECTRONIC BOARDS.....57

TOUCH SCREEN PANEL57

 New Installation.....59

 Software Update63

PLC BOARD mounted in the electrical panel (U500).....66

PLC BOARD mounted on the carriage (U550)69

Motor DRIVERS REPLACEMENT72

 TRACTION MOTOR DRIVER.....72

 Up / down CARRIAGE MOTOR DRIVER.....73

 DRIVERS PRESENT on the FILM SPOOL CARRIAGE74

PLC BOARDS DESCRIPTION (PLC04ROB)75

 PLC BOARD mounted on the ELECTRICAL BOX (U500)75

 PLC BOARD mounted on the CARRIAGE (U550).....78

CHECK CORRECT POSITION OF THE BOTTOM CARRIAGE POSITION CAM.....81

ALARM LIST.....82

 Emergency Button Alarm E100182

 Emergency Bumper Alarm E100283

 Open Carriage Alarm E1010.....83

 Battery in Charge Alarm E1090.....84

 Motor Alarms E3x10.....85

 TRACTION Alarm E61xx86

 LIFTING group (up/down carriage) Alarm E62xx88

 FILM Alarms E63xx89

 ROPING GROUP Alarms E64xx90

 Alarm E68xx91

 Communication alarms E80xx92

 Alarms E9xxx.....93

CARRIAGES SCHEMATIC DESCRIPTION and FILM PATH

FRD CARRIAGE

FILM Tensioning with MECHANICAL BRAKE

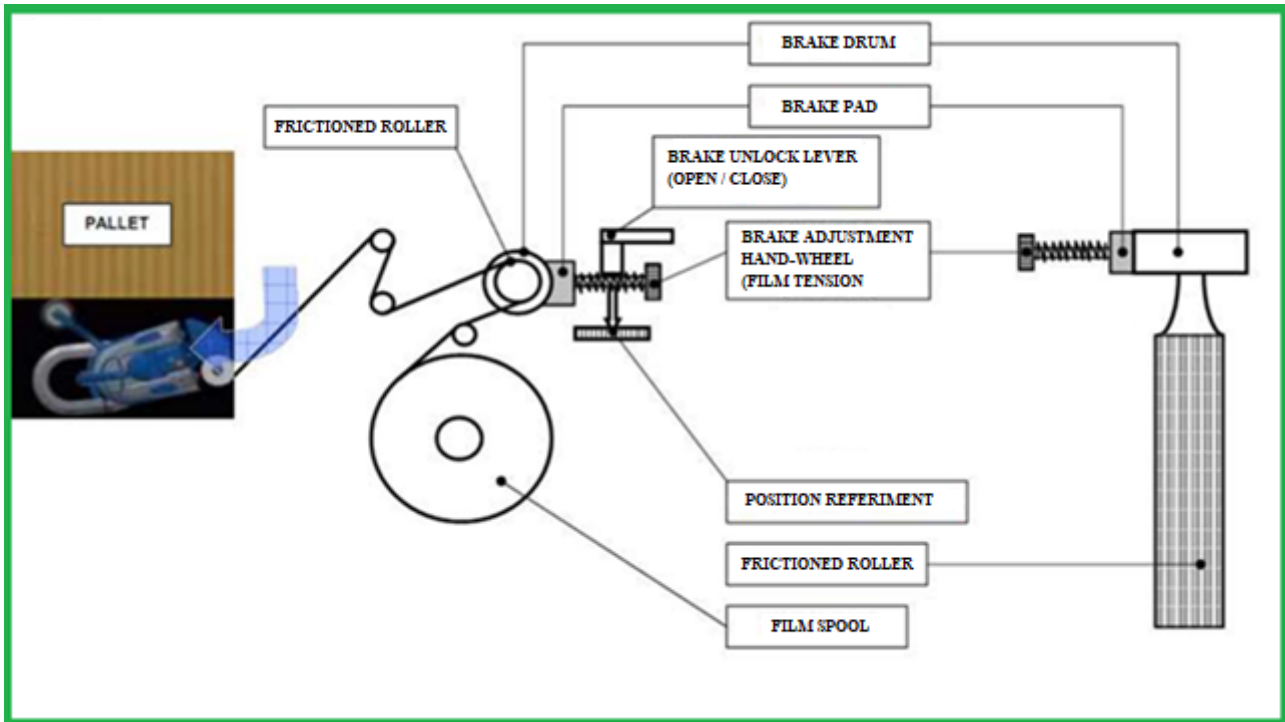

FR CARRIAGE

FILM Tensioning with ELECTROMAGNETIC BRAKE/CLUTCH

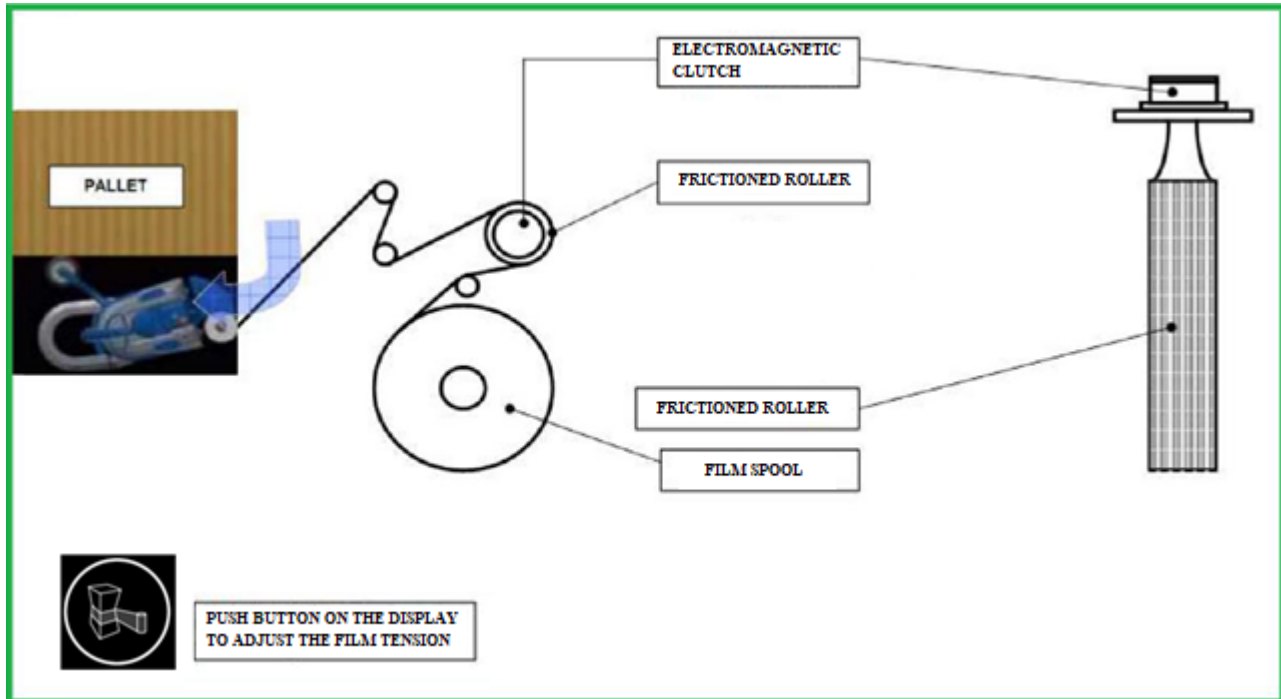

FILM PATH in FRD and FR carriages

FRD

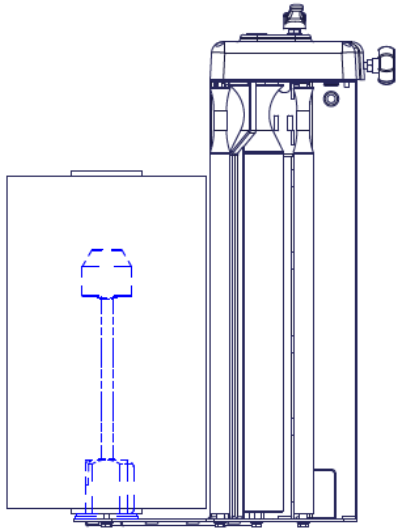

FR

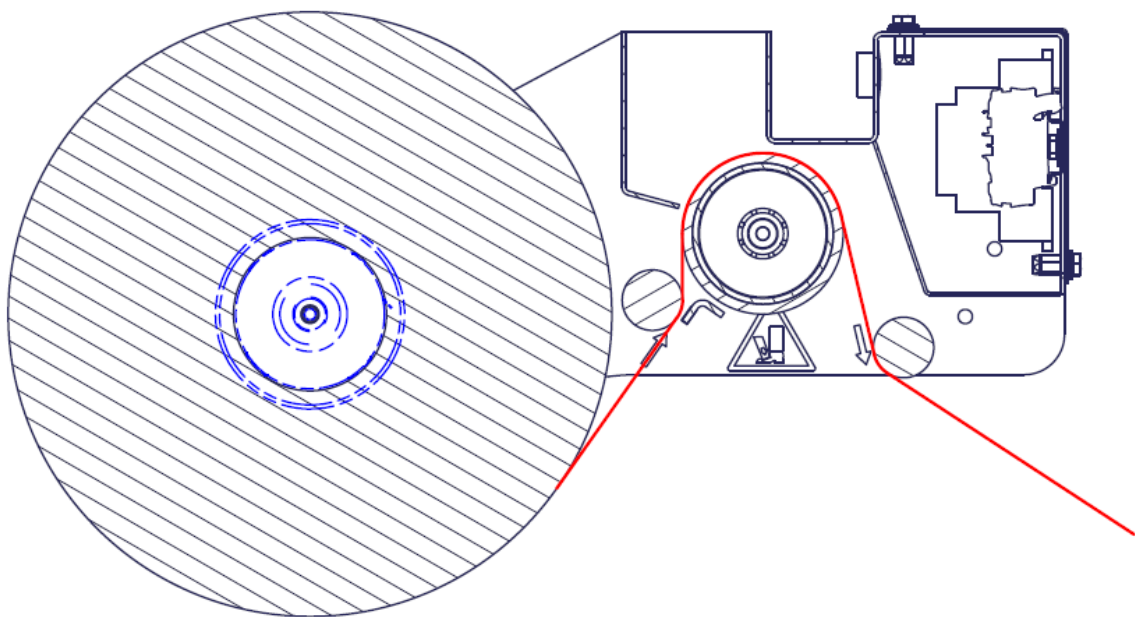
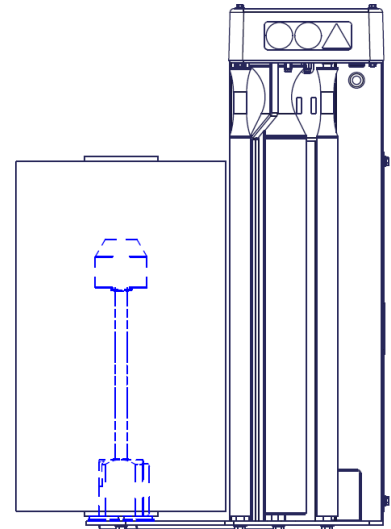

P3GS CARRIAGE

FILM Tensioning with LOAD CELL and FIXED PRESTRETCH (3 values)

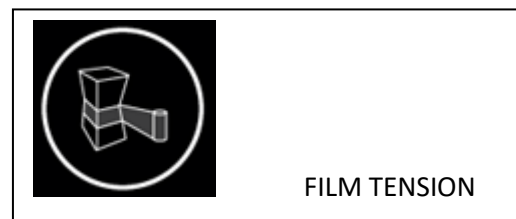
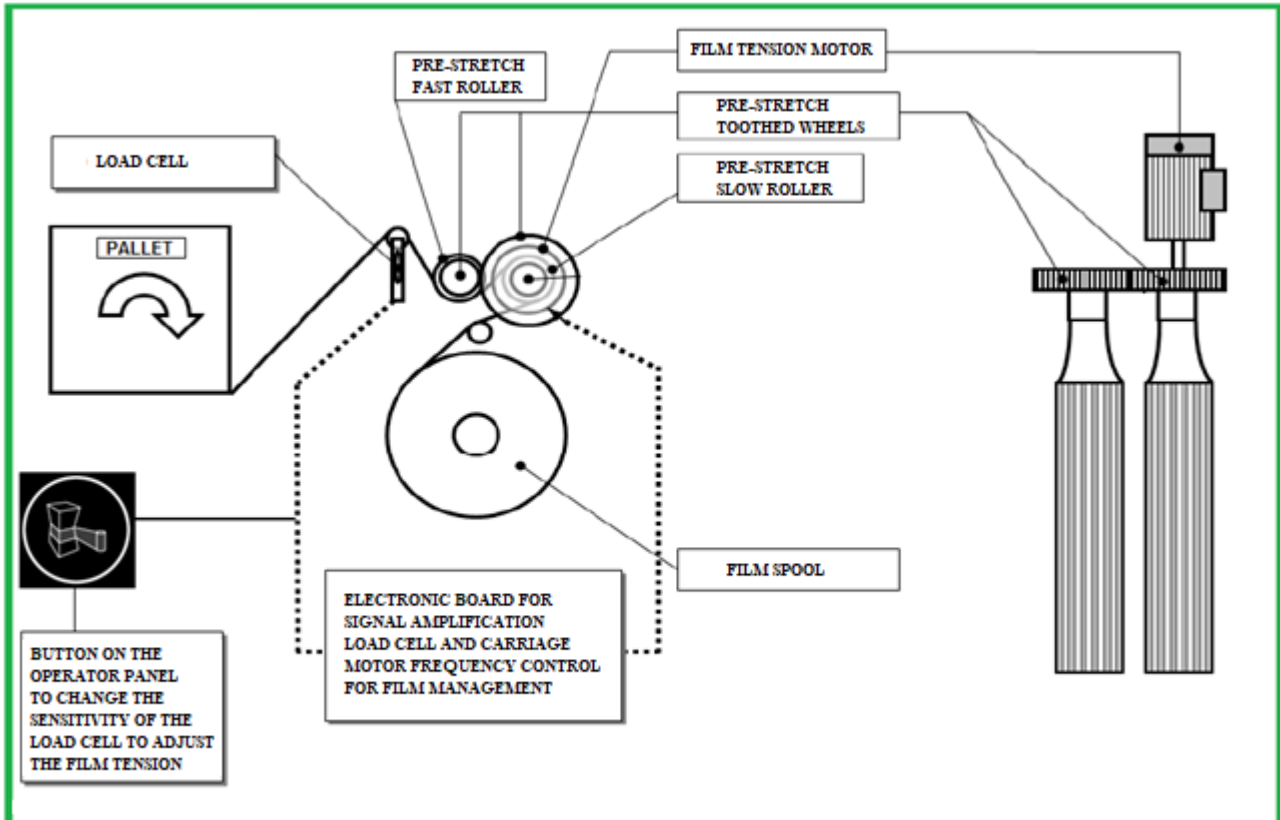

Selectable prestretch

230 %	YELLOW
0 %	GREEN
300 %	RED

PVS CARRIAGE

FILM Tensioning with LOAD CELL and VARIABLE PRESTRETCH

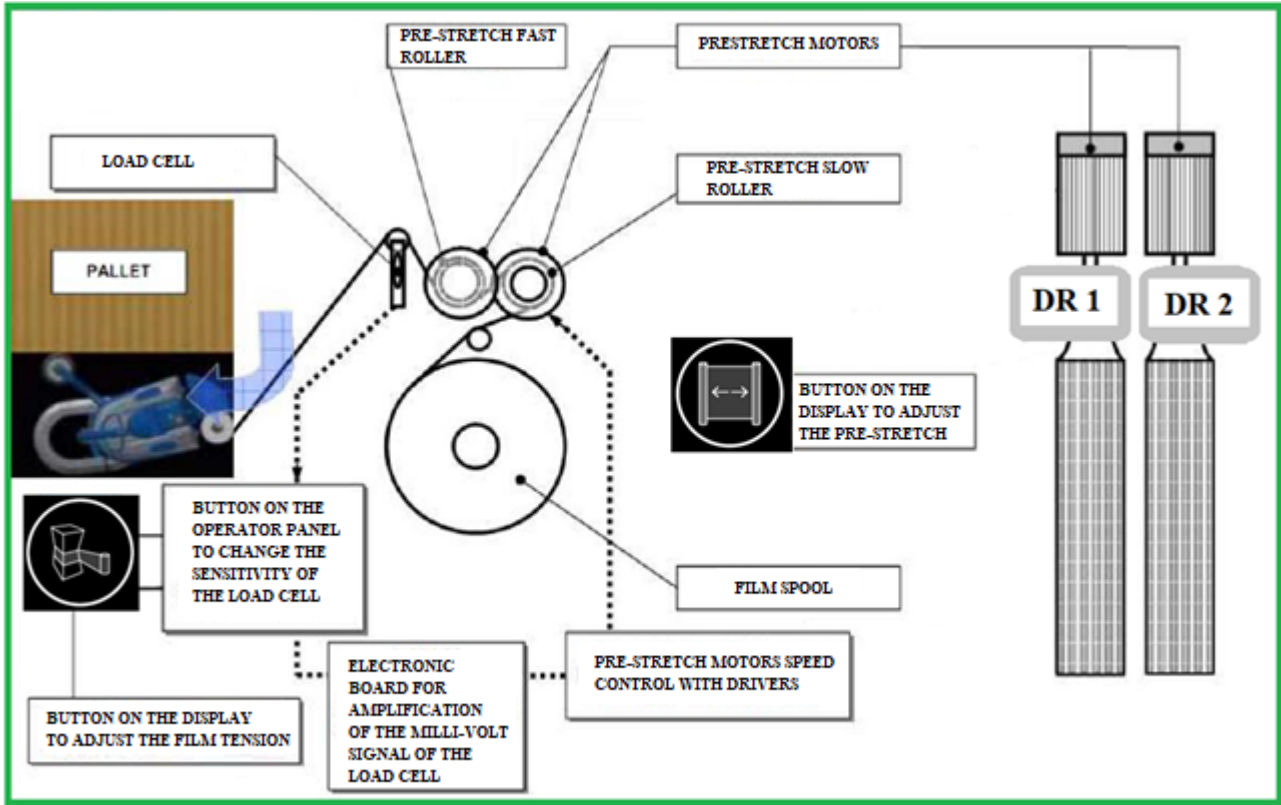

FILM PATH in P3GS and PVS carriages

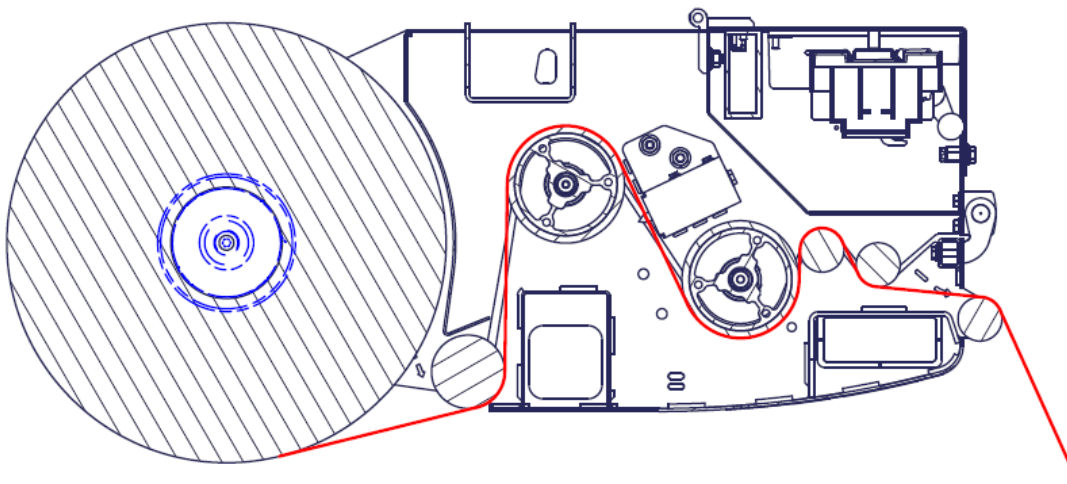
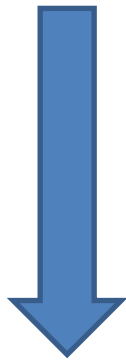
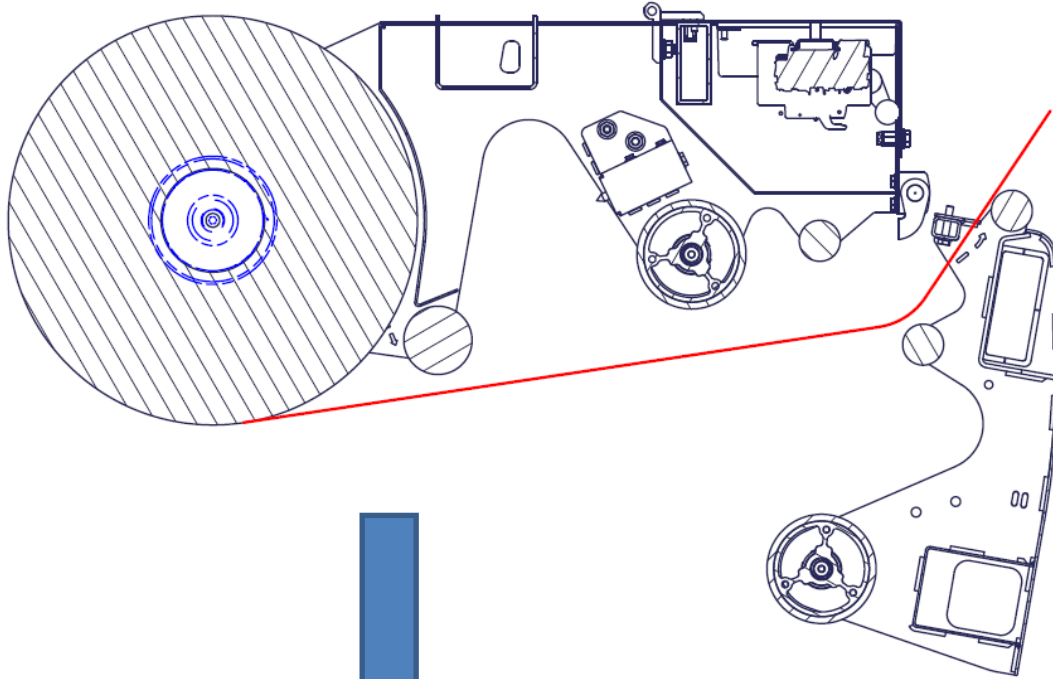

OPERATOR PANEL DESCRIPTION

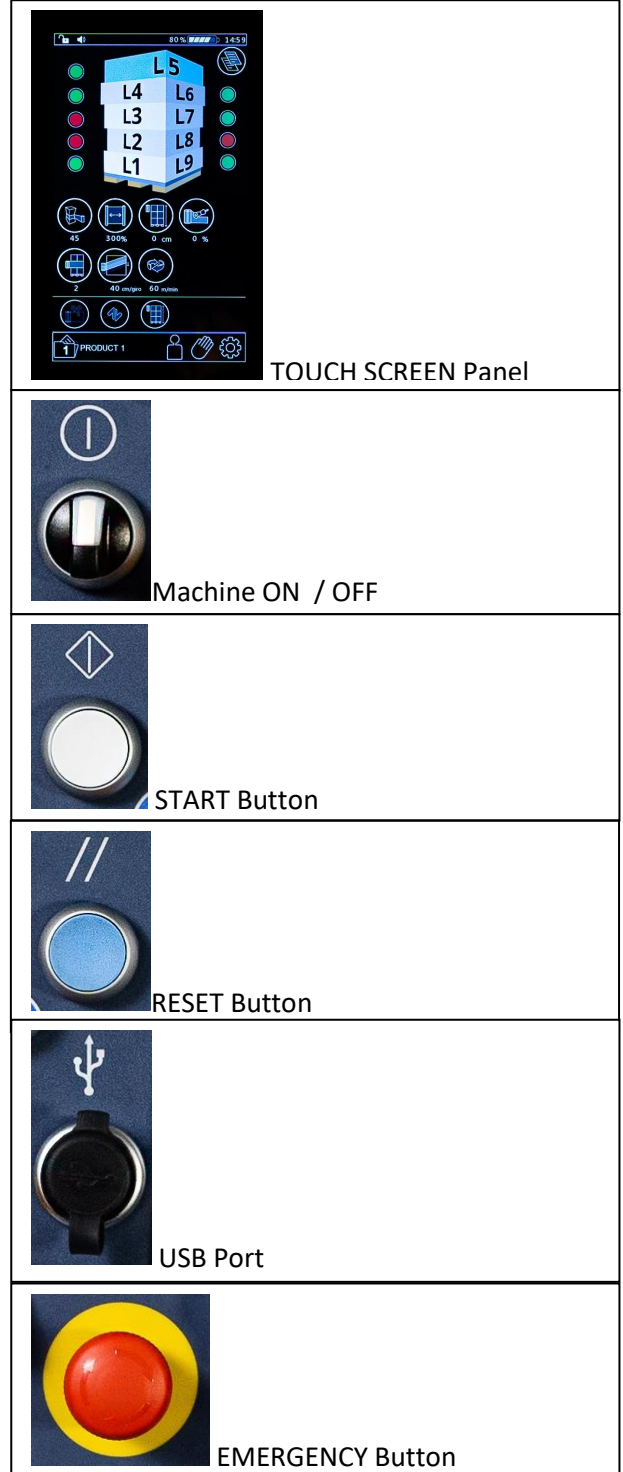
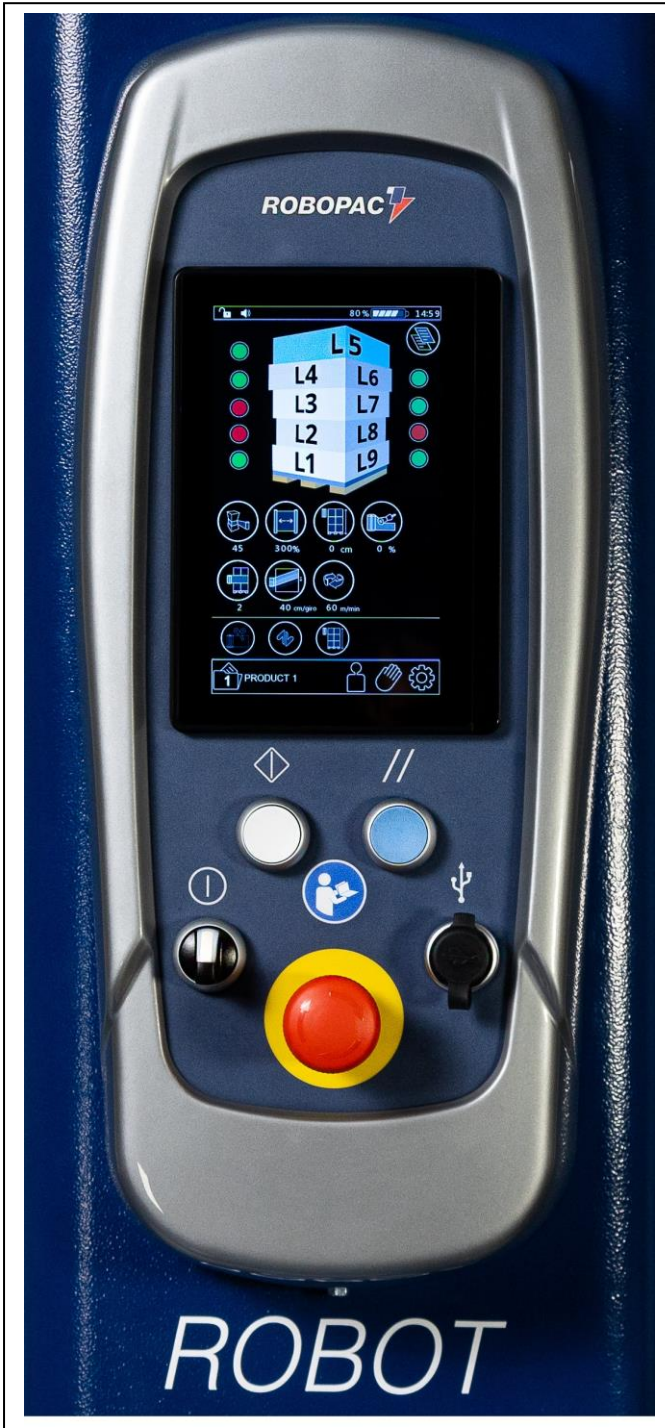

BATTERY STATE DESCRIPTION

The battery level is displayed



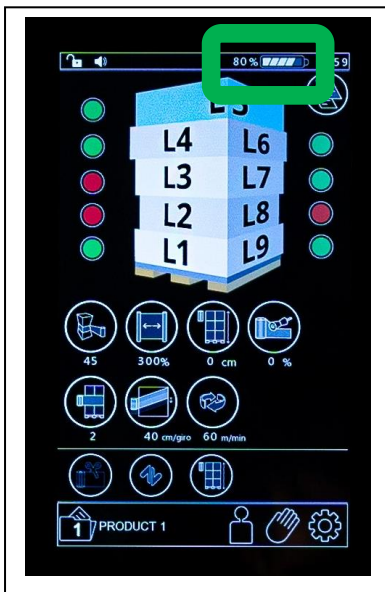

- On the Panel with percentage value
100 % BATTERY TOTALLY FULL







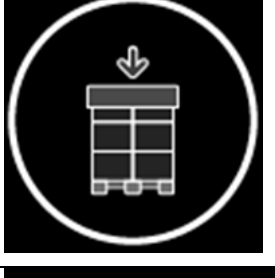
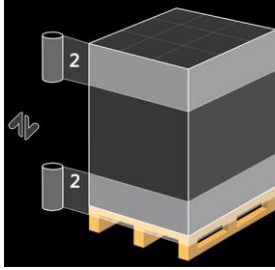



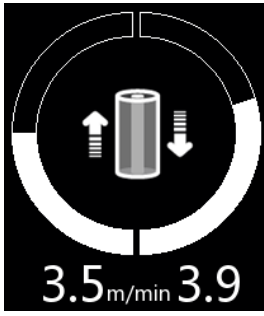

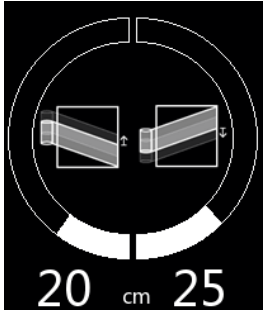

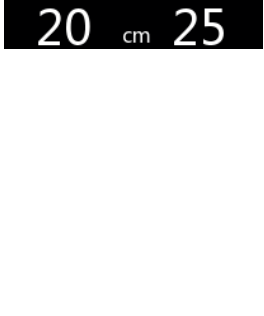
- On the robot carter with green leds ON
All the leds on BATTERY TOTALLY FULL

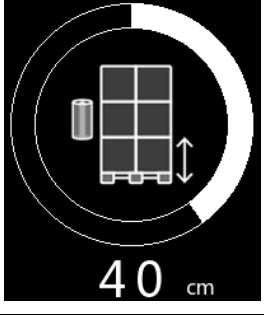

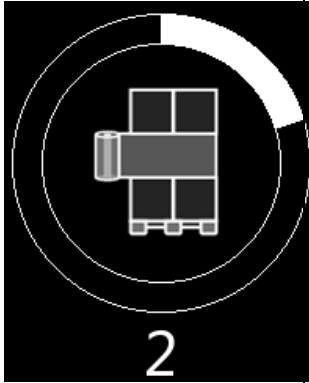

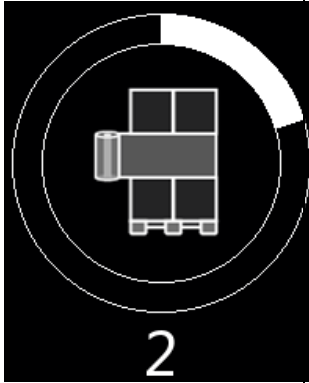
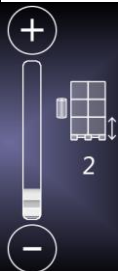

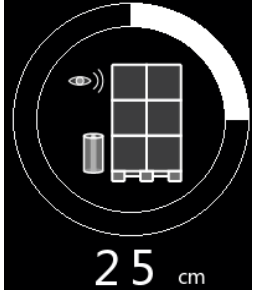
CYCLE PARAMETERS DESCRIPTION

Parameter		Values (min-max)	Step	Unit of measure
Type of packaging cycle		UP and DOWN Cycle		
		ONLY UP or ONLY DOWN Cycle		
		UP and DOWN Cycle with TOP		
Top Turns		0-10	1	Dimensionless
Bottom Turns		0-10	1	Dimensionless
Rotation Speed		35 - 80	1	Meters / minute

Parameter		Values (min-max)	Step	Unit of measure
Carriage Up Speed (meters / minute)		 1.5 – 5.5	0.1	Meters / minute
Carriage Down Speed (meters / minute)		 1.5 – 5.5	0.1	Meters / minute
Carriage Up Centimeters (centimeters of carriage ascent at each turn) similar of F1 CYCLE of Robot S6	<p>SAME</p> <p>BUTTON</p> <p>keep pressed</p> 	 5 – 100	1	Centimeters
Carriage Down Centimeters (centimeters of carriage descent at each turn) similar of F1 CYCLE of Robot S6		 5 – 100	1	Centimeters
Offset from Ground		0 - 100	1	Centimeters

Parameter		Values (min-max)	Step	Unit of measure	
Reinforcement Tours			0 - 10	1	Dimensionless
Reinforcement Height			0 - 200	1	Centimeters
Altimeter			50 - 240	1	Centimeters
Photocell Delay		<div style="border: 1px solid black; padding: 5px; width: fit-content;"> <p>SAME</p> <p>BUTTON</p> <p>keep pressed</p> </div>	0 - 100	1	Centimeters
Film Cut		ON - OFF			

Parameter	Values (min-max)	Step	Unit of measure
Roping Turns (from Top to Bottom)	 0 - 10	1	Dimensionless
Roping percentage (from Top to Bottom)	 0% - 100 %	10 %	Percentage
Roping Turns (from Bottom to Top)	 0 - 10	1	Dimensionless
Roping percentage (from Bottom to Top)	 0% - 100 %	10 %	Percentage
Ergonomic ascent	0-100	1	Centimeters



40 %

SAME BUTTON
keep pressed



30 %

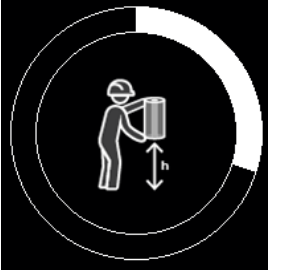

30 cm

 Norm. Tecn. 60.2.109 rev. 00	TECHNICAL DOCUMENTATION ROBOT S7	March 2022	Rev.07
	ENGLISH	Pag. 20 / 93	

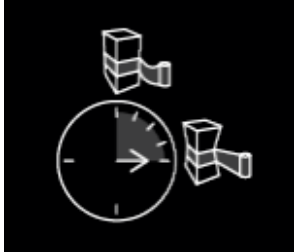

Parameter		Values (min-max)	Step	Unit of measure
Film Tension Delay (at the start) From MARCH 2022		0-10	1	seconds

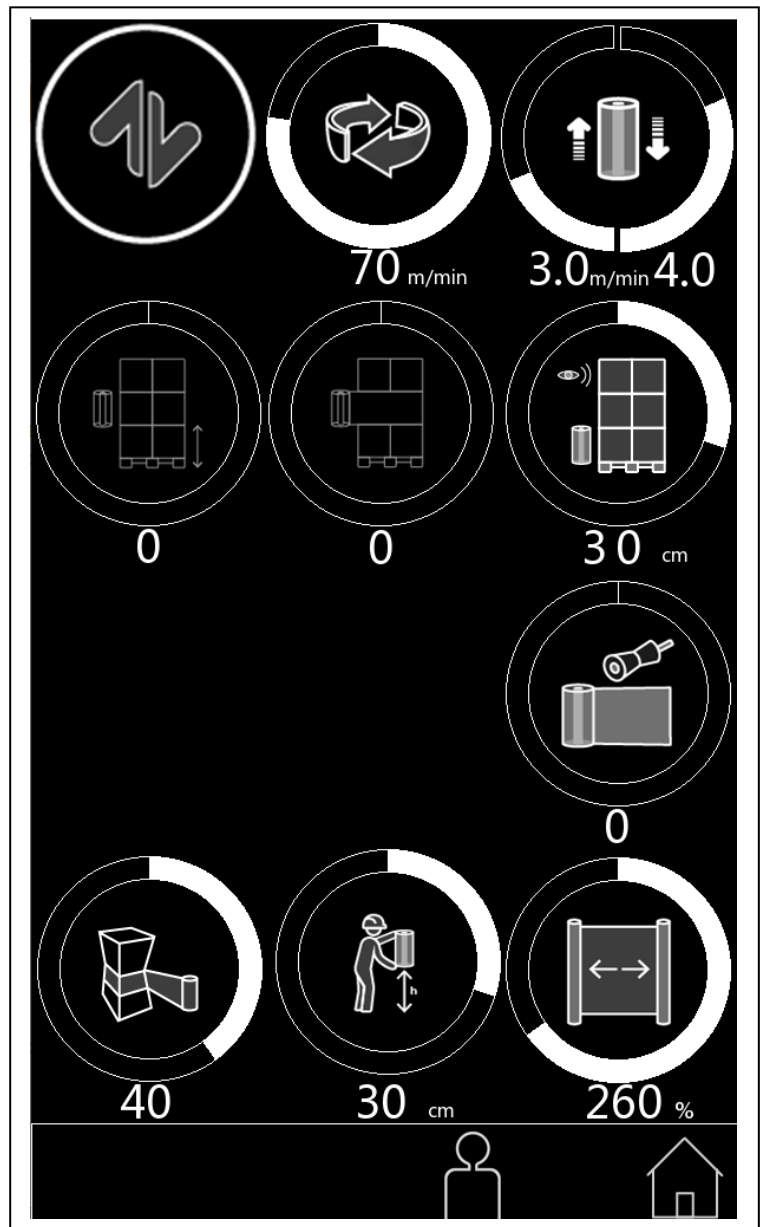
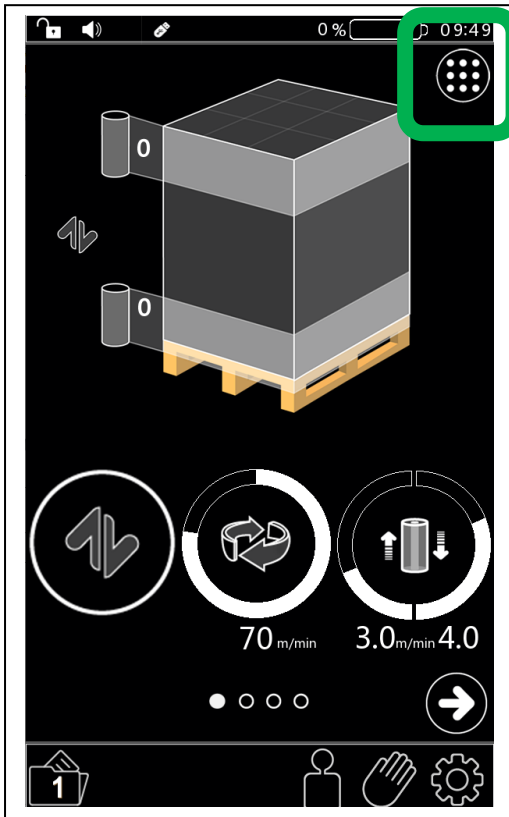
QUICK MENU

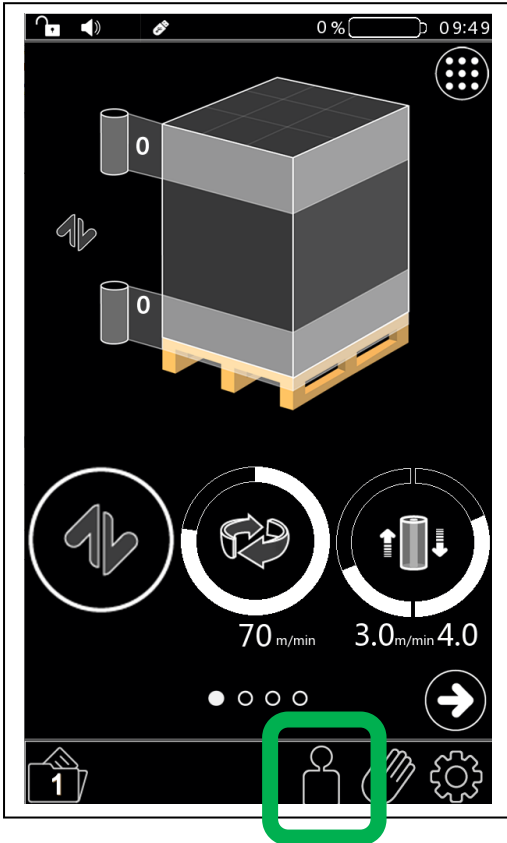

PASSWORDS MANAGEMENT



	<p>Customer Manager Password</p> <p>PSW = 1111</p> <p>Exchangeable (enter with 1111 password)</p>
	<p>SERVICE Password</p> <p>PSW = 6161</p> <p>NOT Exchangeable</p>

 Norm. Tecn. 60.2.109 rev. 00	TECHNICAL DOCUMENTATION ROBOT S7	March 2022	Rev.07
	ENGLISH	Pag. 23 / 93	

Password for VISION SERVICE area



If the user presses the SERVICE page icon



and then press the icon to enter the service area

WITHOUT PASSWORD

a pop-up will appear as below

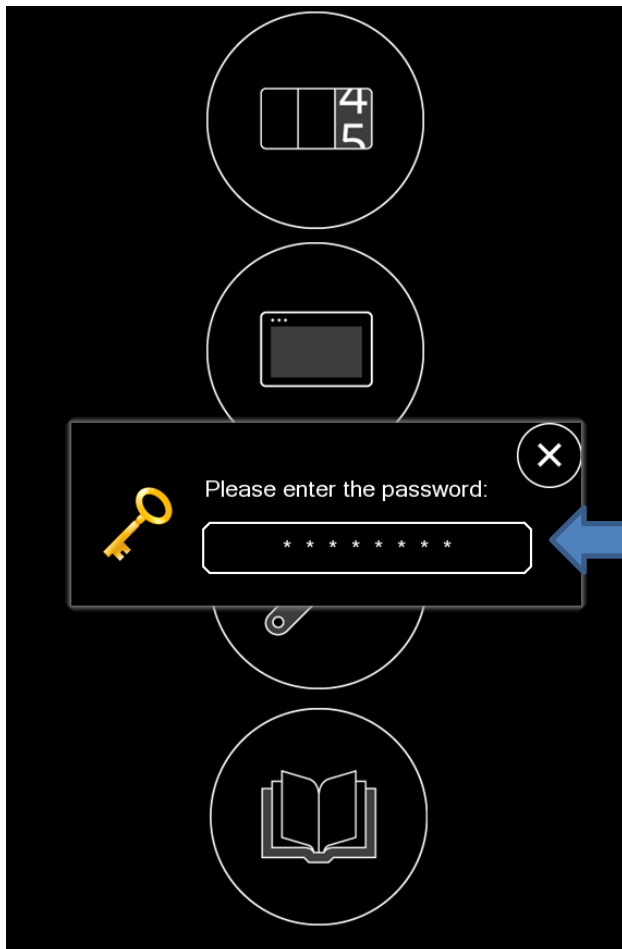

Insert the

PASSWORD = 2021

To enter as **DISPLAY ONLY MODE**

in the service area

 Norm. Tecn. 60.2.109 rev. 00	TECHNICAL DOCUMENTATION ROBOT S7	March 2022	Rev.07
	ENGLISH	Pag. 24 / 93	

RESET of the Customer Manager password to 1111



It is possible at any time to reset the Customer Manager password to 1111

- When switching on, wait for the RESET PRESSURE page
- Press the corners in SEQUENCE [1] then [2] then [3] then [4]



- The pop-up **PASSWORD RESET to 1111** is displayed

MANUAL OPERATIONS ON THE CARRIAGE



To move the carriage in manual, press

With SERVICE password ALL manual operations are possible

With CUSTOMER MANAGER password ONLY some manual operations are possible
Carriage, Roping, Cut-- > No Film Tension Motor (M3) and Prestretc Motor (M4)

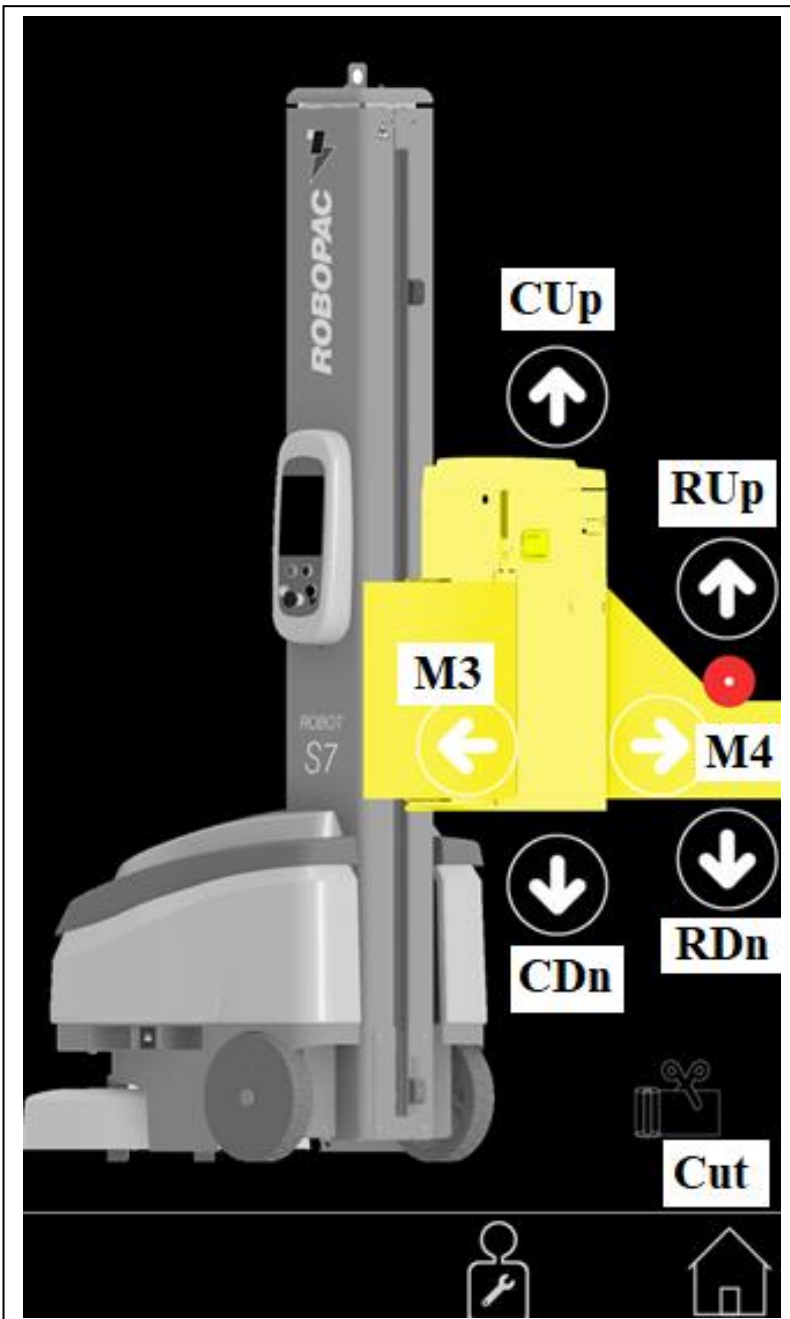

CUp = CARRIAGE UP

CDn = CARRIAGE DOWN

RUp = ROPING UP

RDn = ROPING DOWN

Cut = FILM CUT

M3 = Film Tension Motor

M4 = Prestretch Motor

MANUAL OPERATIONS ON THE STEERING WHEEL

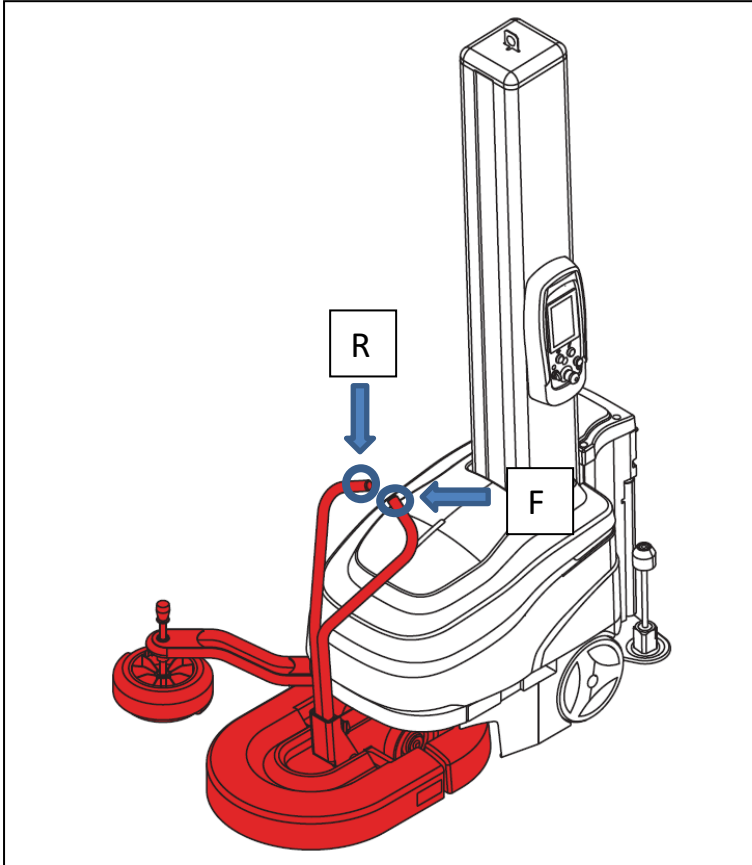

Button F :

Robot forward in Manual

Button R :

Robot backward in Manual

FAST FORWARD in Manual

By keeping pressed the FORWARD button F and repeatedly pressing the backward button R

The Robot Advancement SPEED is INCREASED

Higher number of pulses of the
R button with F button pressed



Higher speed of the Robot in
manual forward

 Norm. Tecn. 60.2.109 rev. 00	TECHNICAL DOCUMENTATION ROBOT S7	March 2022	Rev.07
	ENGLISH	Pag. 27 / 93	

CIRCULAR LED MEANING

The circular LED has different colors depending on the state of the machine



RED	Alarm
WHITE	Manual operations
GREEN	Waiting for START
BLUE	Waiting for RESET
YELLOW	Machine working

CYCLE SELECTION

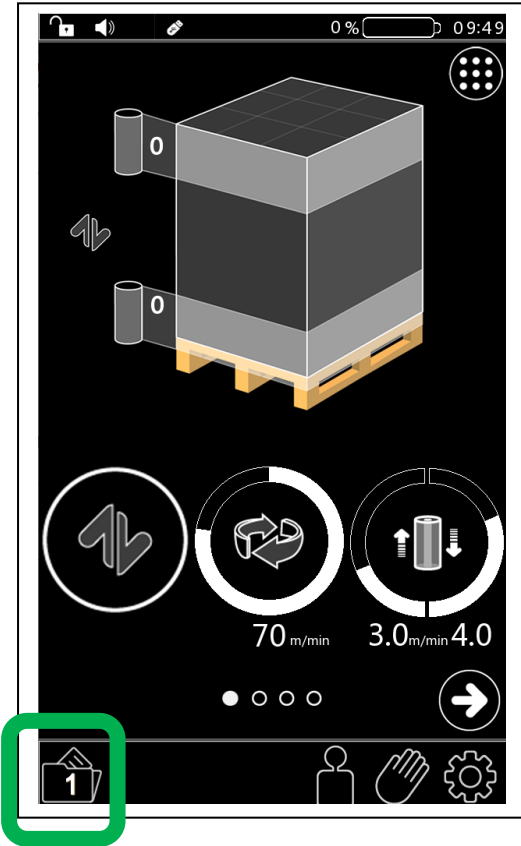



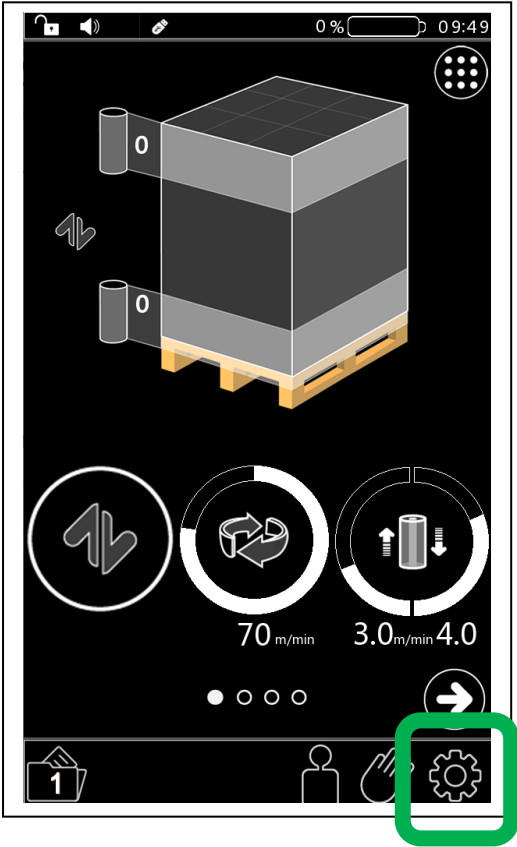

STANDARD Cycle

MULTILAYER Cycle

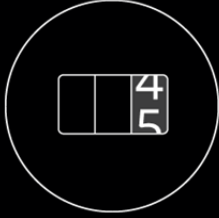
SERVICE PAGES



	Counters		Service Pages
	Various settings and information		Documents and video

COUNTERS

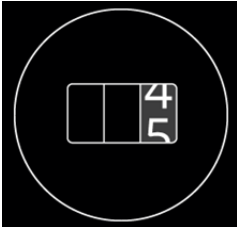

Partial number of cycles
Resettable with
Password 1111 or 6161

VARIOUS SETTINGS AND INFORMATION

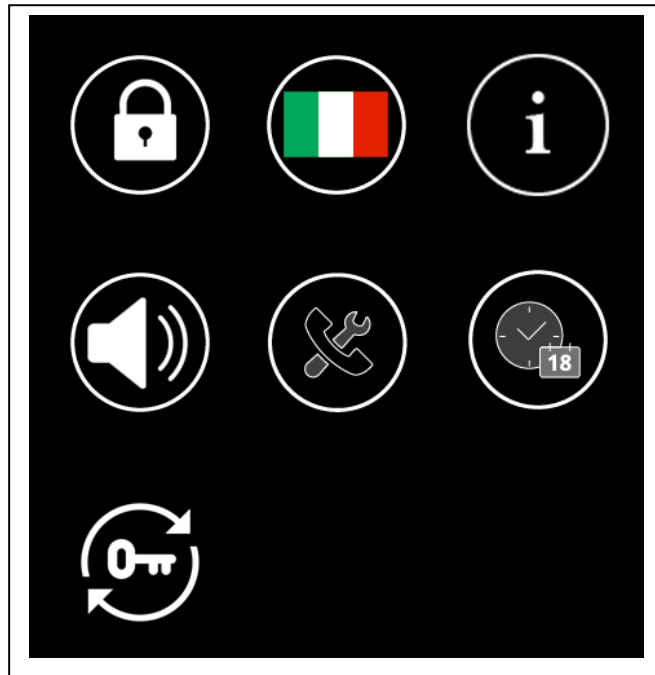

Language Selection



Boards and Software Information



Acoustic Signal



Assistance Phone



Date and Hour

WITHOUT
PASSWORD



Parameters Lock / Unlock



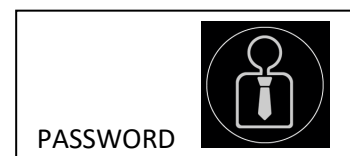

Change of the Customer Manager Password

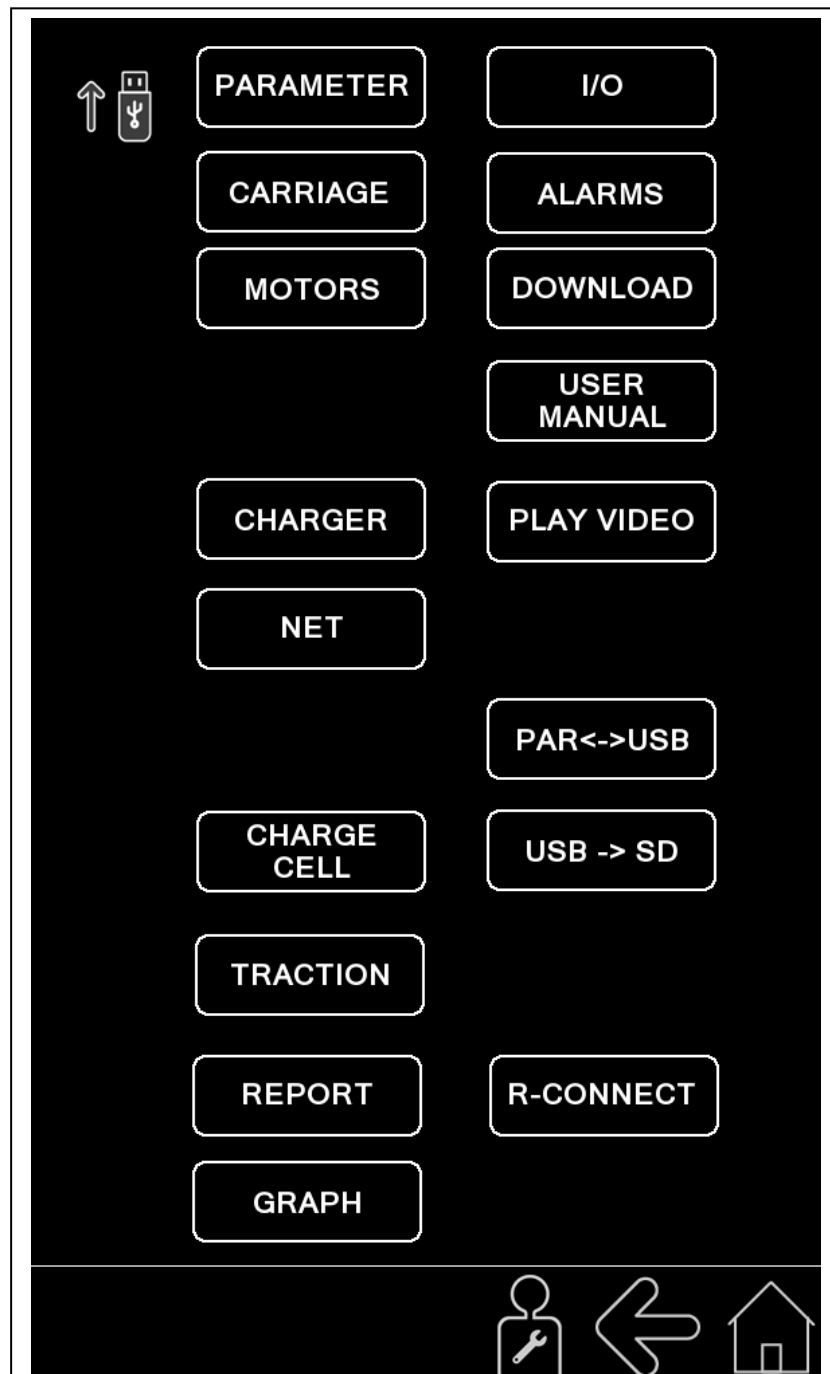

SERVICE PAGES

access **ONLY** with **PASSWORDS**



 Norm. Tecn. 60.2.109 rev. 00	TECHNICAL DOCUMENTATION ROBOT S7	March 2022	Rev.07
	ENGLISH	Pag. 33 / 93	

CONFIGURATION PARAMETERS

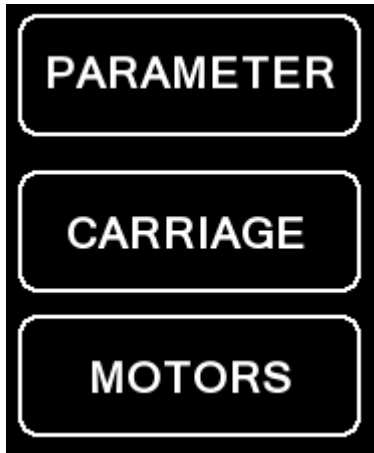

Vision with Customer Manager Password



Modification with Service Password



 Norm. Tecn. 60.2.109 rev. 00	TECHNICAL DOCUMENTATION ROBOT S7	March 2022	Rev.07
	ENGLISH	Pag. 34 / 93	

ACCESS to CONFIGURATION PARAMETERS





For the modification the password 6161 is required





Press on

 Norm. Tecn. 60.2.109 rev. 00	TECHNICAL DOCUMENTATION ROBOT S7	March 2022	Rev.07
	ENGLISH	Pag. 35 / 93	

CONFIGURATION PARAMETERS DEFAULT

Press  and confirm the pop up window displayed 

IF PRESENT  PRESS the button to write the panel parameters to the memory
 The "W" becomes **RED** to indicate the writing then becomes **GREEN** as confirmation of the end of writing

IF NOT PRESENT  the ROBOT automatically saves the parameters to the memory and displays to the RESET page

 Norm. Tecn. 60.2.109 rev. 00	TECHNICAL DOCUMENTATION ROBOT S7	March 2022	Rev.07
	ENGLISH	Pag. 36 / 93	

LIST of the CONFIGURATION PARAMETERS until March 2022

Below is the list of configuration parameters, after any modification (password 6161 required)



IF PRESENT  PRESS the button to write the panel parameters to the memory

The "W" becomes **RED** to indicate the writing then becomes **GREEN** as confirmation of the end of writing

IF NOT PRESENT  TURN OFF/ON the ROBOT to write the parameters to the memory

Parameter	Values	Default	Parameter Description
P1	EU – US	EU	U.S.A. DISPLAY Enable
P2	21.0 – 25.0	23.7	V Min BATTERY Voltage
P3	ON - OFF	OFF	Beeper Enable during the Cycle
P4	0 - 90	30	Auto power OFF Time – minuts
P5	0 - 50	25	Top Descent – centimeters
P6	ON - OFF	ON	Steering wheel Alarm Enable
P7	500 - 750	500	Spool Height
P8	0.0 – 10.0	0	Prestretch delay Seconds of prestretch activation delay (PVS)
P9	Pb - Li	Pb	Battery Type
P10	-1000 +1000	-500	K Traction Correction on lap calculation (360 °), do not modify
P11	ON- OFF	OFF	Traction Alarm
P12	OFF – ON – ON FAST	0	Film cutting enable (ON FAST does NOT provide for the slowdown during the cutting preparation phase, the slowdown has been introduced to improve and make the cut repeatable regardless of the machine starting point)
P13	0 – 200	80	Tail Lenght film cut
P14 – P17	0	0	Free
P18	0 – 200	55	Film density g / 5m
P19	2200 – 2400 - 2800 - 3000	2200	Mast Height
P20	200 - 500	500	Max Prestretch (only for PVS)
P21	OFF	OFF	Enable Graphic (Robopac only)
P22	0	0	Restart (Robopac only)
P23	OFF	OFF	Simulation (Robopac only)
P24	0 - 360	320	Advance Stop Angle at which the robot goes in low speed during the last turn for zero position
P25	OFF	OFF	Comm + (Robopac only)
P26	0 – 20	0	Charger (battery charger analysis warning not implemented)
P27	OFF	OFF	(Robopac only)
P28 – P30	0	0	Free

 Norm. Tecn. 60.2.109 rev. 00	TECHNICAL DOCUMENTATION ROBOT S7	March 2022	Rev.07
	ENGLISH	Pag. 37 / 93	

LIST of the CONFIGURATION PARAMETERS from March 2022

Below is the list of configuration parameters, after any modification (password 6161 required)



TURN OFF/ON the ROBOT to write the parameters to the memory

Parameter	Values	Default	Parameter Description
P1	EU – US	EU	U.S.A. DISPLAY Enable
P2	21.0 – 25.0	23.7	V Min BATTERY Voltage
P3	ON - OFF	OFF	Beeper Enable during the Cycle
P4	0 - 90	30	Auto power OFF Time – minuts
P5	0 - 50	25	Top Descent – centimeters
P6	ON - OFF	ON	Free
P7	500 - 750	500	Spool Height
P8	0.0 – 10.0	0	Free
P9	Pb - Li	Pb	Battery Type
P10	-1000 +1000	-500	K Traction Correction on lap calculation (360 °), do not modify
P11	ON- OFF	OFF	Traction Alarm
P12	OFF – ON – ON FAST	0	Film cutting enable (ON FAST does NOT provide for the slowdown during the cutting preparation phase, the slowdown has been introduced to improve and make the cut repeatable regardless of the machine starting point)
P13	0 – 200	80	Tail Lenght film cut
P14 – P17	0	0	Free
P18	0 – 200	55	Film density g / 5m
P19	2200 – 2400 - 2800 - 3000	2200	Mast Height
P20	200 - 500	500	Max Prestretch (only for PVS)
P21	OFF	OFF	Enable Graphic (Robopac only)
P22	0	0	Restart (Robopac only)
P23	OFF	OFF	Simulation (Robopac only)
P24	0 - 360	320	Advance Stop Angle at which the robot goes in low speed during the last turn for zero position
P25	OFF	OFF	Comm + (Robopac only)
P26	0 – 20	0	Charger (battery charger analysis warning not implemented)
P27	OFF	OFF	(Robopac only)
P28 – P30	0	0	Free

 Norm. Tecn. 60.2.109 rev. 00	TECHNICAL DOCUMENTATION ROBOT S7	March 2022	Rev.07
	ENGLISH	Pag. 38 / 93	

ACCESS to CARRIAGE PARAMETERS



For the modification the password 6161 is required





Press on

 Norm. Tecn. 60.2.109 rev. 00	TECHNICAL DOCUMENTATION ROBOT S7	March 2022	Rev.07
	ENGLISH	Pag. 39 / 93	

DEFAULT of the CARRIAGE PARAMETERS

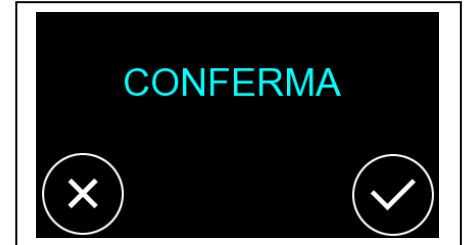
Press  and confirm the pop up window displayed



Press  to write the panel parameters to the memory

The “W” button becomes **RED** to indicate the writing then becomes **GREEN** as confirmation of the end of writing

 Norm. Tecn. 60.2.109 rev. 00	TECHNICAL DOCUMENTATION ROBOT S7	March 2022	Rev.07
	ENGLISH	Pag. 40 / 93	

LIST of the CARRIAGE PARAMETERS



Below is the list of carriage parameters, after any modification (password 6161 required)



Press  to write the panel parameters to the memory

The “W” button becomes **RED** to indicate the writing then becomes **GREEN** as confirmation of the end of writing

Parameter	Values	Default	Parameter Description
C1	FRD – FR P3GS - PVS	FRD	Type of the Carriage
C2	ON - OFF	OFF	Roping
C3	0 - 100	30	KP Film treatment, proportional constant
C4	0 - 100	59	KI Film treatment, integrative constant
C5	0 – 100	3	KD Film treatment, derivative constant
C6	0 - 100	20	TMIN Minimum deviation of the cell under which the film treatment does not work
C7	0 - 100	80	DELTA Distance (* 10) between cell value for film tension = 0 and film tension = 100
C8	OFF ROLLER CELL BOTH	OFF	Film Break Alarm ROLLER = R-connect film consumption roller CELL = load cell BOTH = both (roller and cell)
C9	0 - 100	70	PWM Clutch % PWM of the clutch for maximum film tension in FR
C10	0 - 100	30	KPrest prestretch constant
C11	0 - 100	60	Roping Advance Encoder pulses before the target to be traversed at low speed
C12	0 - 100	30	Roping Max Stretch Maximum film tension during roping
C13	0 - 100	10	Roping Min Stretch Minimal film tension during roping
C14	0.0 – 10.0 (dSec)	0	Time Manual Film Indicates how long the rollers continue to rotate after releasing the manual film button
C15	0.015 – 1.000 (Sec)	0.015	Photocell Delay Photocell filter to filter any small erroneous readings
C16 – C20	0	0	Free

 Norm. Tecn. 60.2.109 rev. 00	TECHNICAL DOCUMENTATION ROBOT S7	March 2022	Rev.07
	ENGLISH	Pag. 41 / 93	

ACCESS to MOTOR PARAMETERS



For the modification the password 6161 is required





Press on

 Norm. Tecn. 60.2.109 rev. 00	TECHNICAL DOCUMENTATION ROBOT S7	March 2022	Rev.07
	ENGLISH	Pag. 42 / 93	

MOTOR PARAMETERS DEFAULT

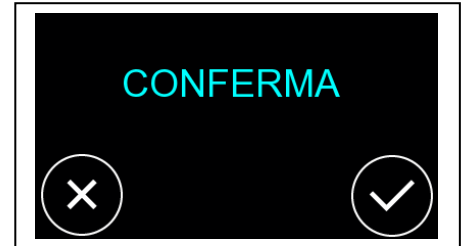
Press  and confirm the pop up window displayed



Press  to write the panel parameters to the memory

The “W” button becomes **RED** to indicate the writing then becomes **GREEN** as confirmation of the end of writing

 Norm. Tecn. 60.2.109 rev. 00	TECHNICAL DOCUMENTATION ROBOT S7	March 2022	Rev.07
	ENGLISH	Pag. 43 / 93	

LIST of the MOTOR PARAMETERS



Below is the list of motor parameters, after any modification (password 6161 required)



Press  to write the panel parameters to the memory

The “W” button becomes **RED** to indicate the writing then becomes **GREEN** as confirmation of the end of writing

MXYY : **X = motor number**

1 rotation 2 carriage 3 tension 4 prestretch 5 roping

YY = parameter number (01-20)

Par.	Parameter Description	ROTATION Motor 1 Default	CARRIAGE Motor 2 Default	FILM TENSION Motor 3 Default	PRESTRETCH Motor 4 Default	ROPING Motor 5 Default
Mx01	N POLI	M101 = 4	M201 = 4	M301 = 4	M401 = 4	M501 = 4
Mx02	HALL	M102 = 32	M202 = 32	M302 = 32	M402 = 32	M502 = 32
Mx03	ACC	M103 = 2000	M203 = 500	M303 = 130	M403 = 30	M503 = 300
Mx04	DEC	M104 = 100	M204 = 100	M304 = 130	M404 = 30	M504 = 100
Mx05	QSTOP	M105 = 100	M205 = 100	M305 = 100	M405 = 100	M505 = 50
Mx06	INom	M106 = 20	M206 = 15	M306 = 20	M406 = 20	M506 = 10
Mx07	l2t	M107 = 15	M207 = 15	M307 = 10	M407 = 10	M507 = 10
Mx08	vKP	M108 = 15	M208 = 40	M308 = 40	M408 = 50	M508 = 5
Mx09	vKl	M109 = 6	M209 = 24	M309 = 10	M409 = 10	M509 = 2
Mx10	vFilter	M110 = 100	M210 = 200	M310 = 200	M410 = 200	M510 = 200
Mx11	tBrake	M111 = 10	M211 = 10	M311 = 10	M411 = 10	M511 = 10
Mx12	cKP	M112 = 250	M212 = 280	M312 = 500	M412 = 500	M512 = 800
Mx13	cKl	M113 = 100	M213 = 120	M313 = 100	M413 = 100	M513 = 600
Mx14	rStatore	M114 = 20	M214 = 25	M314 = 30	M414 = 30	M514 = 190
Mx15	hSincrona	M115 = 7	M215 = 10	M315 = 20	M415 = 20	M515 = 26
Mx16	flusso	M116 = 100	M216 = 94	M316 = 90	M416 = 90	M516 = 50
Mx17	iMax	M117 = 70	M217 = 50	M317 = 45	M417 = 45	M517 = 20
Mx18	Libero	M118 = 0	M218 = 0	M318 = 0	M418 = 0	M518 = 0
Mx19	Libero	M119 = 0	M219 = 0	M319 = 0	M419 = 0	M519 = 0
Mx20	Libero	M120 = 0	M220 = 0	M320 = 0	M420 = 0	M520 = 0



 Norm. Tecn. 60.2.109 rev. 00	TECHNICAL DOCUMENTATION ROBOT S7	March 2022	Rev.07
	ENGLISH	Pag. 44 / 93	

LOAD CELL CALIBRATION

After to be sure that

- No Film is present on the rollers
- The roller connected to the load cell to be in correct mechanical conditions

Enter with the SERVICE password 6161  or Customer manager password 

Press  then press 

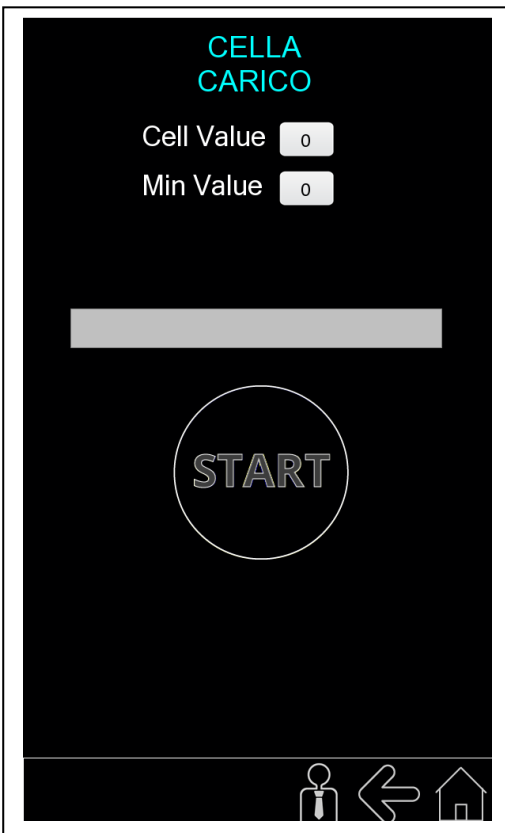

PRESS

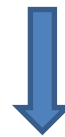
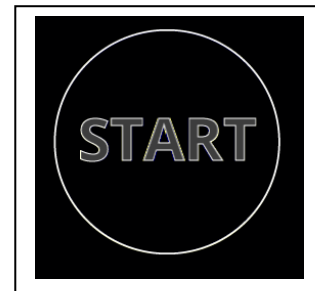

Calibration OK

Calibration
NOT correct

 Norm. Tecn. 60.2.109 rev. 00	TECHNICAL DOCUMENTATION ROBOT S7	March 2022	Rev.07
	ENGLISH	Pag. 45 / 93	

VARIABLE ROPING CALIBRATION/SETTING

In the case of variable roping problems, in case of installation of the roping group, in case of change of the carriage PLC and in case of Alarm E6404 make the ROPING DEVICE CALIBRATION



Enter with the SERVICE password 6161



Press

then press

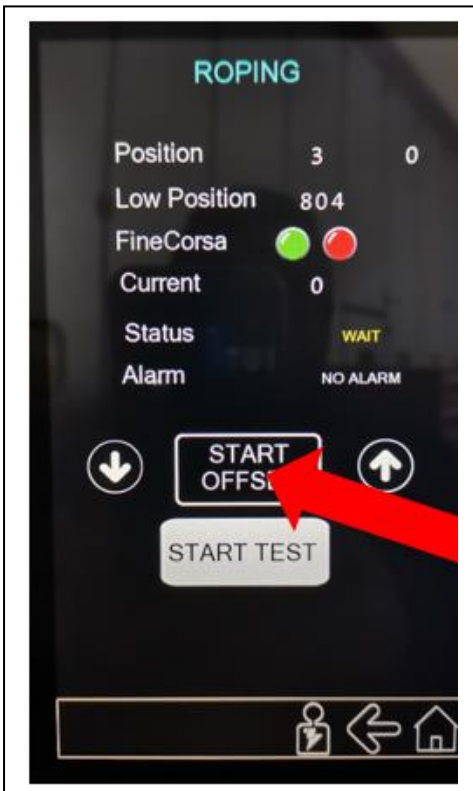

Press **"START OFFSET"** and wait the end of the AUTOMATIC TEST.

During the cycle the two icons of the limit switches turn on.

When the **Status** indication turns green, the procedure is completed correctly

CARRIAGE TEST CYCLE

Enter to the REPORT page pressing the buttons in sequence



Start the LIFTING cycle (L) --- > **WITHOUT FILM SPOOL** on the **CARRIAGE**

to allow to the software to register all the values related to the operation of the carriage.



At the end of the cycle the values at the left underlined in red are filled with the values detected during the cycle.

The values detected can be send with Rconnect with

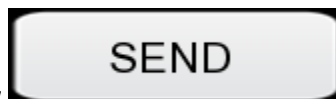

the button at the top right indicated by the arrow

The GLOBAL cycle has to be eventually performed **WITH FILM SPOOL MOUNTED** on the **CARRIAGE**

COMUNICATION CHECK between DEVICES

Enter to the NET page with the sequence of the buttons

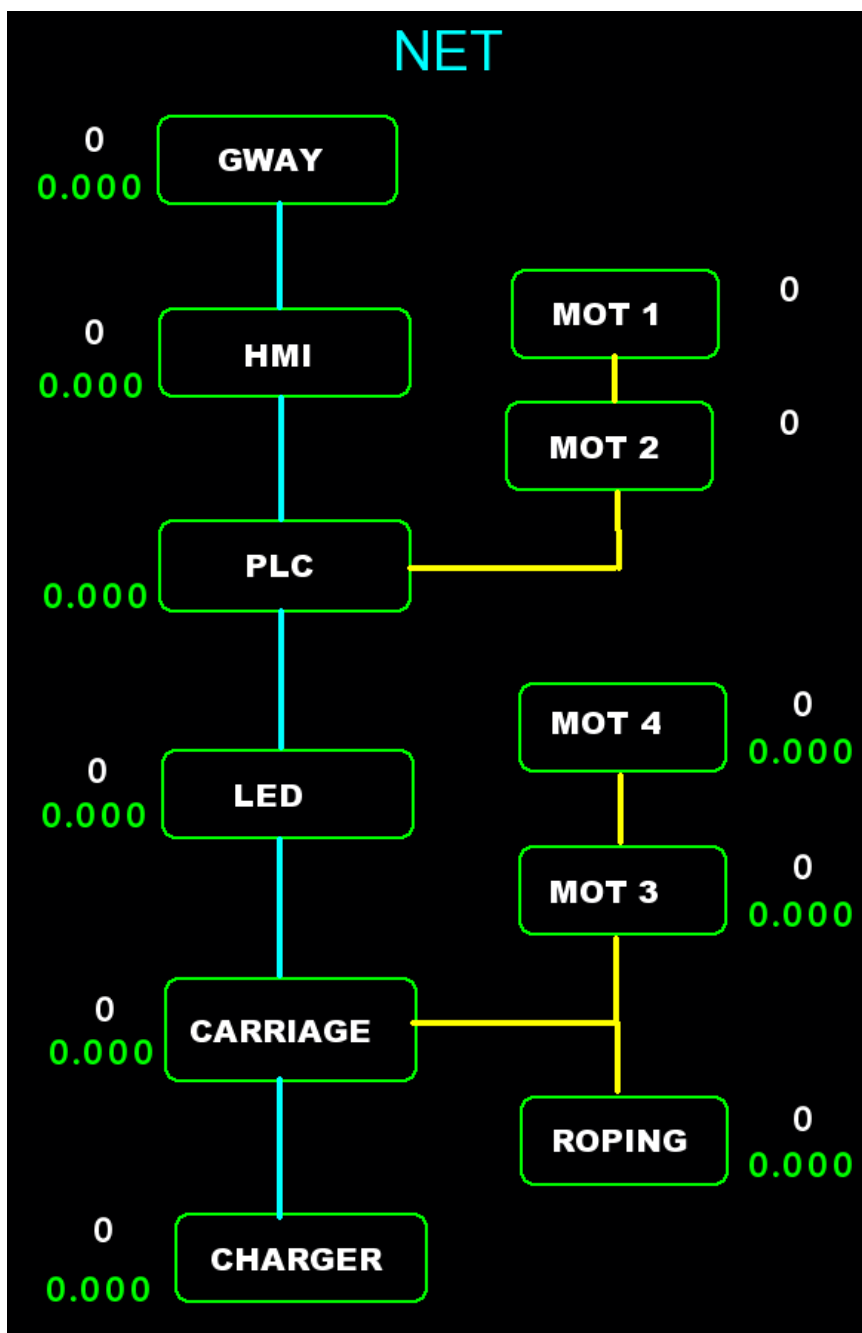

CAN Communication

--- YELLOW CONNECTIONS ---

MODBUS Communication

--- BLUES CONNECTIONS ---

- **GTWAY** = R-Connect
- **HMI** = Touch Screen
- **PLC** =
PLC on the electrical box
- **LED** = LED Module
- **CARRIAGE** =
PLC on the CARRIAGE
- **CHARGER** =
Battery Charger
- **MOT1** = Driver for Traction Motor
- **MOT2** = Driver for Carriage Motor (up/down)
- **MOT3** = Driver for Film Tension Motor
- **MOT4** = Driver for Prestretch Motor
- **ROPING** = Driver for Roping Motor

 Norm. Tecn. 60.2.109 rev. 00	TECHNICAL DOCUMENTATION ROBOT S7	March 2022	Rev.07
	ENGLISH	Pag. 49 / 93	

PRODUCT HEIGHT DETECTION PHOTOCELL CALIBRATION

STANDARD PHOTOCELL (for clear products)

Adjust the photocell sensitivity trimmer about to load center;

approximately set the trimmer to time 2

(looking the photocell from back in order to read the written DL).

PHOTOCELL FOR BLACK PRODUCTS S62

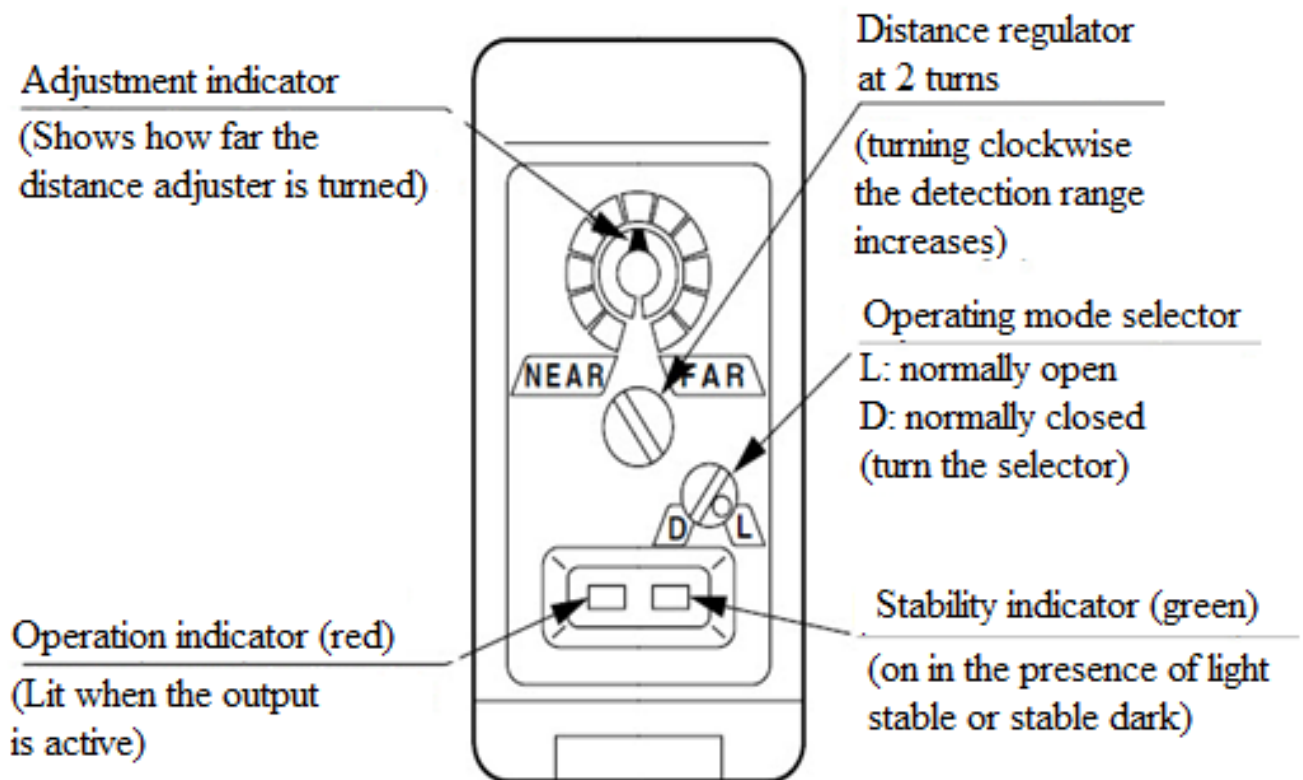

Set the "Operating mode selector" to L mode (turn the selector clockwise as far as it will go).

READING DISTANCE ADJUSTMENT

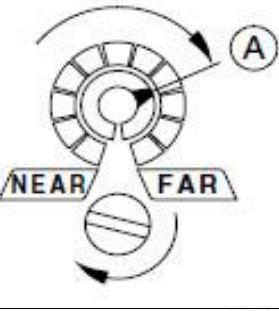
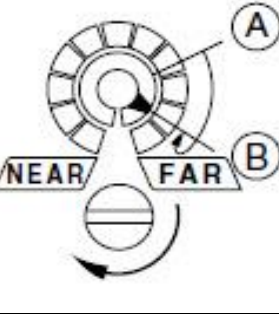
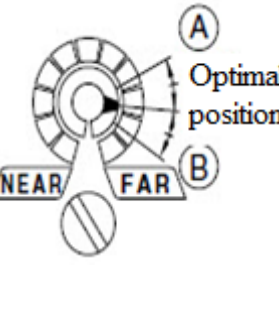
Description	Distance selector
<p>Turn completely the selector counter clock-wise direction in case of minimum distance (about 0.2mm).</p>	 <p>Turn completely</p>
<p>Locate the object to detect from the photocell (pallet centre) and turn the selector clock-wise direction till "A" to set the photocell in "light" condition (output active)</p>	
<p>Remove the a.m. object. Turn the selector in clock-wise direction till switch again the photocell to "light" condition. When it become on, turn again the selector to switch to "dark" to "B"</p> <p>(if absence of the object to detect the photocell do not switch to "light" condition ON, the "B" point must be considered like maximum point of the setting range).</p>	
<p>Set the selector to half range (middle between point "A" and point "B" that should be the best point to detect the object</p>	

 Norm. Tecn. 60.2.109 rev. 00	TECHNICAL DOCUMENTATION ROBOT S7	March 2022	Rev.07
	ENGLISH	Pag. 51 / 93	

PHOTOCELL FOR BLACK PRODUCTS S65

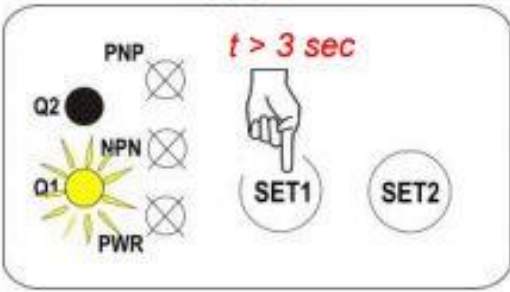
	<p>Place the target at the center of the pallet</p>
<p style="text-align: center;">Teach-In</p> 	<p>Keep pressed the Set1 button for more than 3 seconds, till the Q1 flashing</p>
	<p>Release the button, target detected</p>

 Norm. Tecn. 60.2.109 rev. 00	TECHNICAL DOCUMENTATION ROBOT S7	March 2022	Rev.07
	ENGLISH	Pag. 52 / 93	

“POWER SAVE” FUNCTION

after 15 minuts the machine turns to POWER SAVE mode --- > touch screen

AUTO POWER OFF FUNCTION

the machine turns off autonomously after the minutes written in the general parameter P [4]

default value P [4] = 30 ---> auto-off after 30 minutes

LITHIUM BATTERY AUTO POER OFF

after 60 minuts when not in use, the LITHIUM battery also turns off



to turn the machine and the lithium battery back on, keep the selector pressed for 5 seconds

 Norm. Tecn. 60.2.109 rev. 00	TECHNICAL DOCUMENTATION ROBOT S7	March 2022	Rev.07
	ENGLISH	Pag. 53 / 93	

BATTERY CHARGER SETTINGS



Enter with the SERVICE password 6161



Press

then press



The battery charge curve must be selected according to the type of battery used.

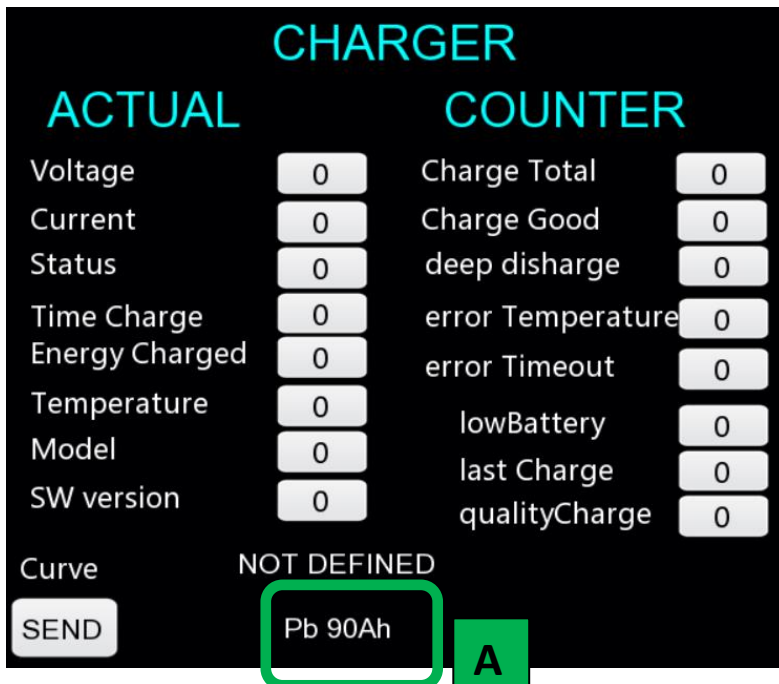

In the SEND section **(A)** select the charge curve according to the battery installed.



Once the battery is selected, press **SEND** then close the window.

Pb 90Ah	00L0605281
Pb 110 Ah 8 ore	0001346639 - 0001346706
Pb PURE	1760300042
Pb GENERIC	
Pb ENERSYS	
Pb RECOVERY	
AGM GEL	0001341436
LITHIUM	00L0553330

CHECK THE CURRENT DELIVERED in the CHARGE PHASE

For NORD ELETTRONICA battery charger connect it to the electrical socket and check that the **BATTERY CHARGER red LED** changes **from FLASHING to STEADY**

At the same time, the CURRENT parameter shown on the display must be greater than 10 A.

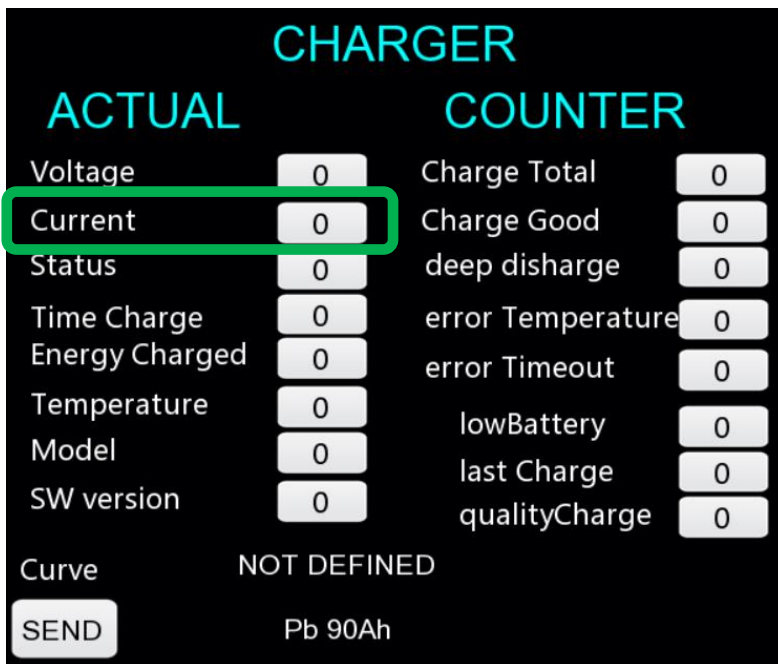

MEANING OF THE LEDS of the battery charger

- Flashing Red :

- Red :

- Yellow :

- Green :

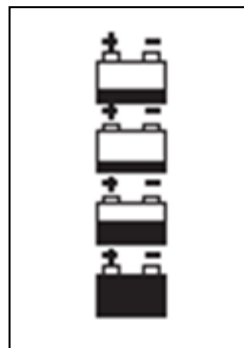

Battery status check phase

First charging phase

Second charging phase

Battery full / Maintenance phase

 Norm. Tecn. 60.2.109 rev. 00	TECHNICAL DOCUMENTATION ROBOT S7	March 2022	Rev.07
	ENGLISH	Pag. 55 / 93	

BATTERYCHARGERS ALARMS

- **1 flash of the yellow led:** Battery disconnected or Polarity inversion or Output Short Circuit

--- > Check the connection to the battery

- **2 flashes of the yellow led:** Time-out alarm: faulty battery or battery capacity too high

--- > The alarm is reset by disconnecting the power supply. If it appears again, consult assistance.

- **3 flashes of the yellow led:** Battery charger faulty alarm

--- > The alarm is reset by disconnecting the power supply. If it appears again, consult assistance.

- **4 flashes of the yellow led:** Overtemperature alarm

--- > The alarm resets itself when the battery charger cools down. Check ventilation.

 Norm. Tecn. 60.2.109 rev. 00	TECHNICAL DOCUMENTATION ROBOT S7	March 2022	Rev.07
	ENGLISH	Pag. 56 / 93	

“RECOVERY” CHARGING CURVE

If you feel a deterioration in the performance of the **LEAD ACID Pb 90 Ah - Pb 110 Ah batteries**, probably related to the performance of NOT COMPLETE CHARGES

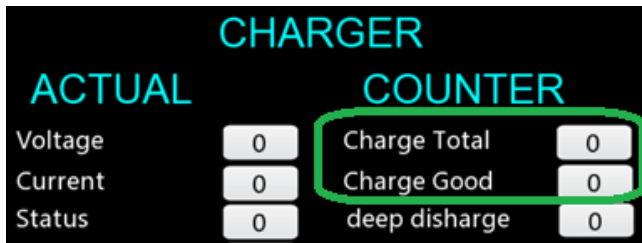

You can do a "RECOVERY" charge lasting about 24 hours (the green LED indicates the end of the charge)



to set this curve enter with the password SERVICE 6161





press

then press

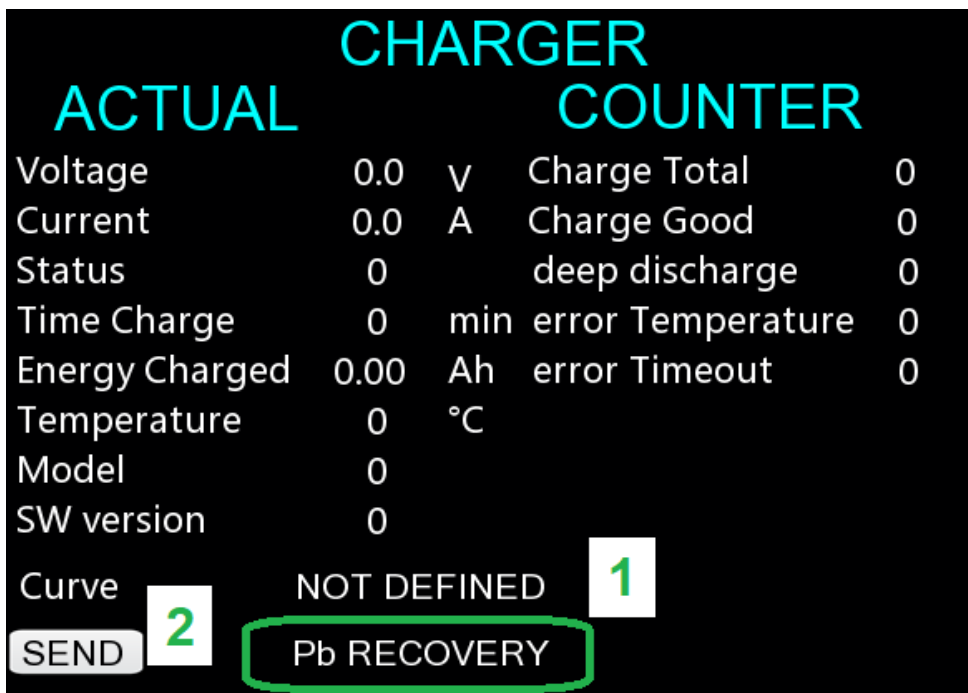

select the **Pb RECOVERY [1]** curve then press **SEND [2]**



 Norm. Tecn. 60.2.109 rev. 00	TECHNICAL DOCUMENTATION ROBOT S7	March 2022	Rev.07
	ENGLISH	Pag. 57 / 93	

PROCEDURES FOR REPLACEMENT, SOFTWARE LOADING AND CALIBRATION OF ELECTRONIC BOARDS

TOUCH SCREEN PANEL

The TOUCH SCREEN is supplied as a spare WITHOUT SOFTWARE inside, in case it is necessary to replace or update the TOUCH SCREEN



Use the USB pen drive containing the original software versions which is supplied with the machine.



Robopac provides the original machine software with the USB 2.0 pen drive housed in the switchboard with all the technical machine documentation.

N.B.: In case it's necessary to create a new installation support (e.g: the original pen drive is lost) with a commercial pen drive:

- *use a USB 2.0 pen drive only*
- *copy the PLC board software files provided by Robopac at first directory level of pen drive*

 PLC04_V0
 PLC04_V1
 Robot_S7_48_20210519_b177.fpg

Example of software files

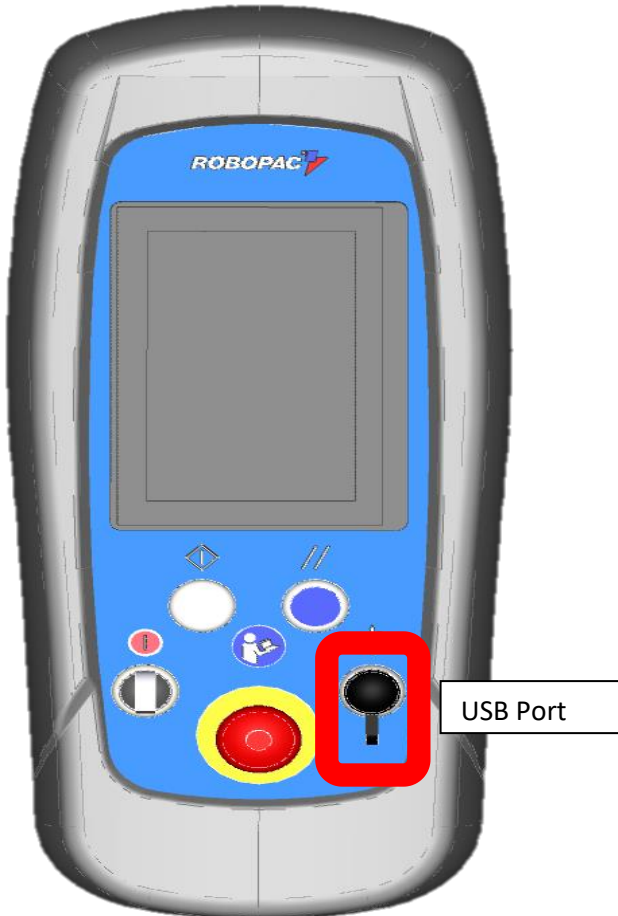

 Norm. Techn. 60.2.109 rev. 00	TECHNICAL DOCUMENTATION ROBOT S7	March 2022	Rev.07
	ENGLISH	Pag. 59 / 93	

New Installation

- Mechanically mount the touch-screen panel in place of the defective one
- Insert the SD card of the defective Touch Screen into the new Touch Screen

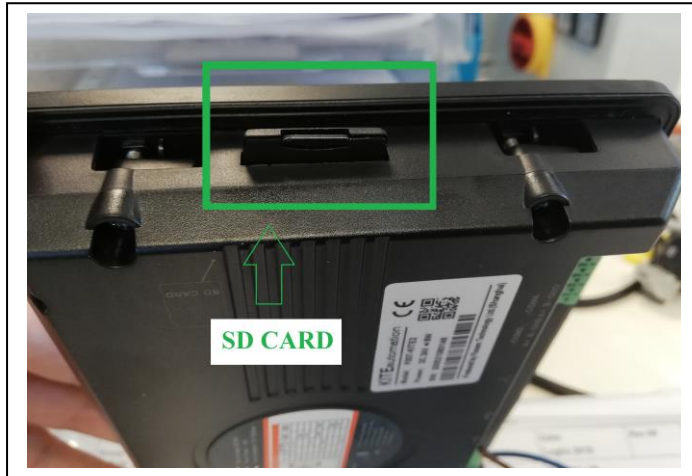

- Electrically wire the panel
- Turn on the machine and wait some seconds
- Insert the USB key into the port on the left of the HMI
- Select “Yes” in the popup window that is shown



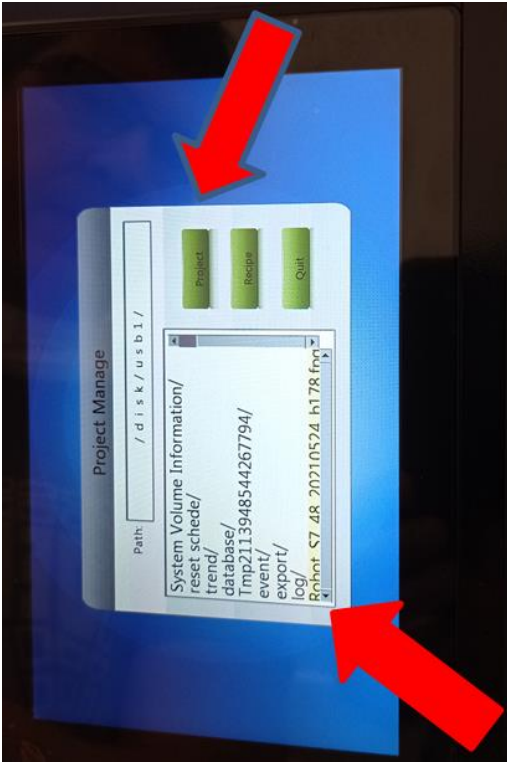

 <p>Norm. Tecn. 60.2.109 rev. 00</p>	TECHNICAL DOCUMENTATION ROBOT S7	March 2022	Rev.07
ENGLISH	Pag. 60 / 93		

- Select the file **ROBOT S7 xxxxxxxxxxxx** then press “Project”

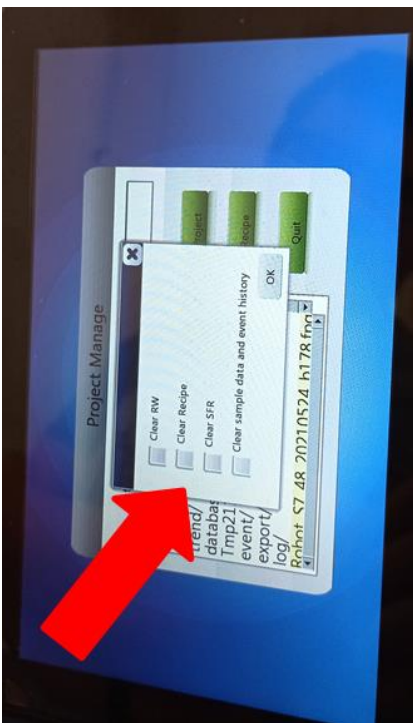

- Activate all the ticks then press OK



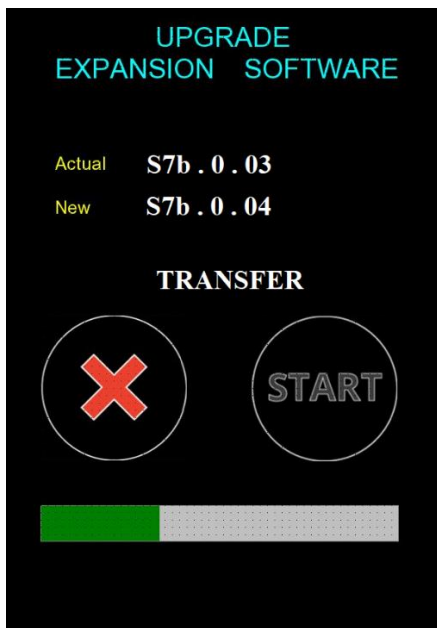

 Norm. Tecn. 60.2.109 rev. 00	TECHNICAL DOCUMENTATION ROBOT S7	March 2022	Rev.07
	ENGLISH	Pag. 61 / 93	

- At the end of the software download, the panel restarts the application
- Press “START” to update the software in the PLC on the pre-stretch carriage

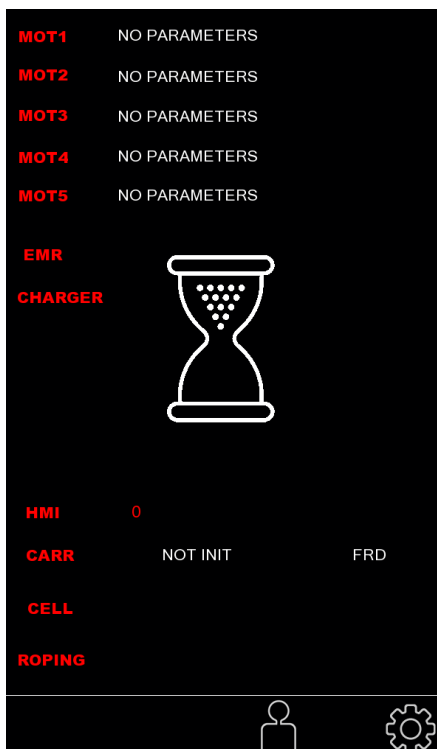

- Once the machine has restarted, this page appears. Turn the machine off and on again.



 Norm. Tecn. 60.2.109 rev. 00	TECHNICAL DOCUMENTATION ROBOT S7	March 2022	Rev.07
	ENGLISH	Pag. 62 / 93	

At the end of the REPLACEMENT and insertion of the software in the TOUCH SCREEN

IT IS NECESSARY to do

(1) The default of the CONFIGURATION PARAMETERS



and subsequent RE-CONFIGURATION of the ROBOT

(2) The default of the CARRIAGE PARAMETERS



and subsequent RE-CONFIGURATION of the CARRIAGE PARAMETERS

(3) Default of RECIPES



 Norm. Techn. 60.2.109 rev. 00	TECHNICAL DOCUMENTATION ROBOT S7	March 2022	Rev.07
	ENGLISH	Pag. 63 / 93	

Software Update



Enter with the Customer Manager password 1111



Access the service page

and then to the



page

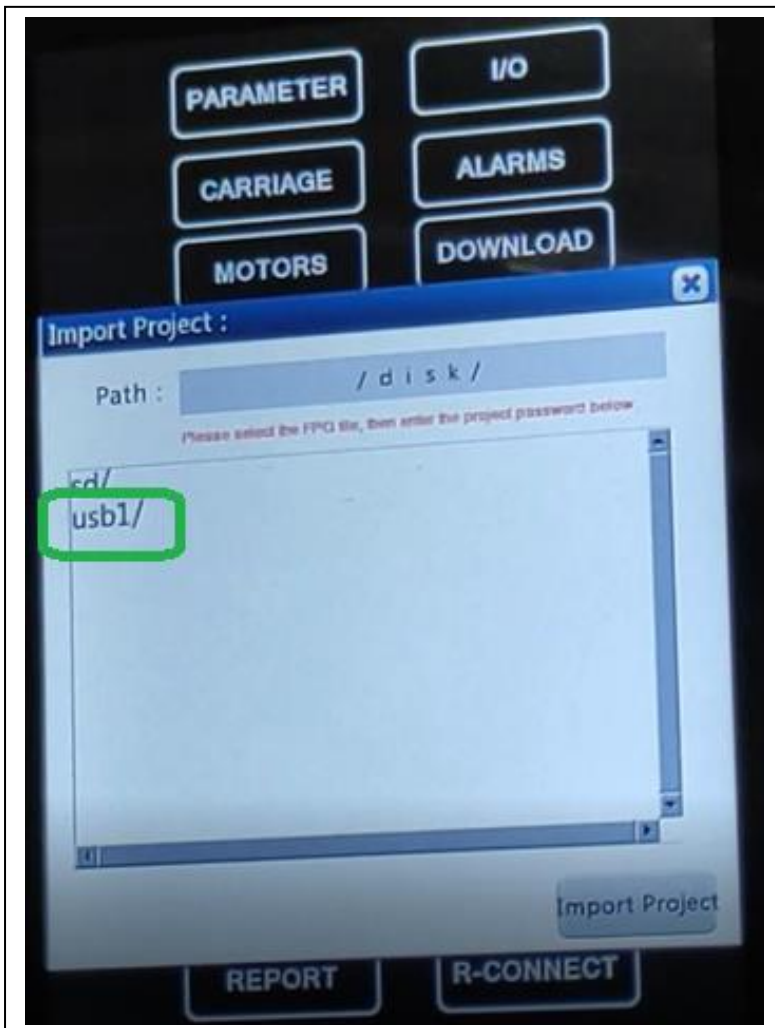

Select usb1/

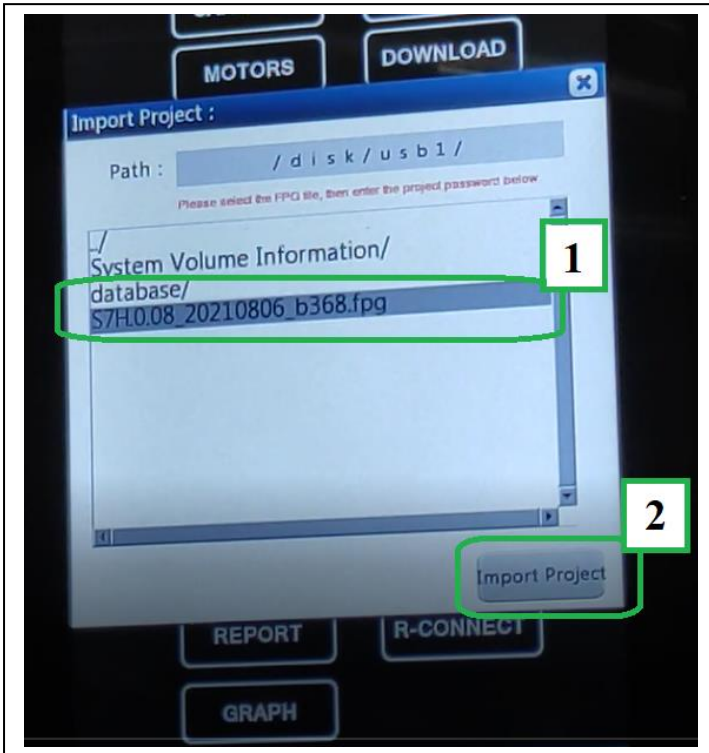

[1] Select the file **fpg**

PLC04_V0

PLC04_V1

Robot_S7_48_20210519_b177.fpg

[2] press **Import Project**

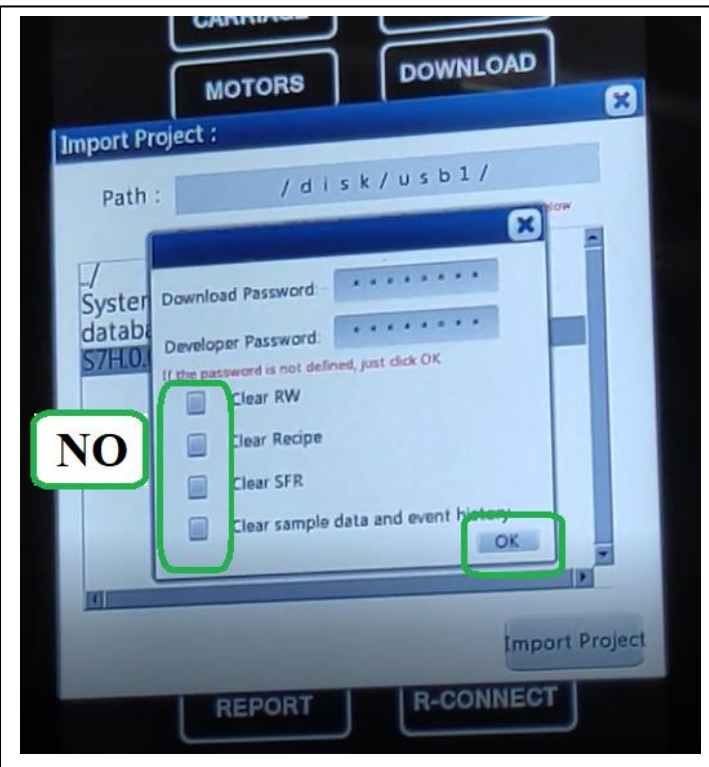

[OK] press **OK**

Without ticking ANYTHING

 Norm. Tecn. 60.2.109 rev. 00	TECHNICAL DOCUMENTATION ROBOT S7	March 2022	Rev.07
ENGLISH	Pag. 65 / 93		

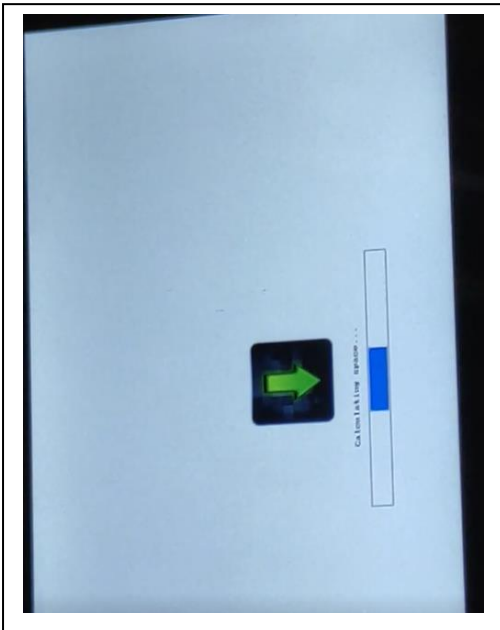

The software is downloaded ...



Operation Concluded

At the end of the simple software UPDATE in the TOUCH SCREEN

IT IS NOT NECESSARY to do other operations on the parameters

 Norm. Tecn. 60.2.109 rev. 00	TECHNICAL DOCUMENTATION ROBOT S7	March 2022	Rev.07
	ENGLISH	Pag. 66 / 93	

PLC BOARD mounted in the electrical panel (U500)

The PLC is supplied as a spare WITHOUT SOFTWARE inside, in case it is necessary to replace or update the PLC

Use the USB pen drive containing the original software versions which is supplied with the machine.



Robopac provides the original machine software with the USB 2.0 pen drive housed in the switchboard with all the technical machine documentation.

N.B.: In case it's necessary to create a new installation support (e.g: the original pen drive is lost) with a commercial pen drive:

- *use a USB 2.0 pen drive only*
- *copy the PLC board software files provided by Robopac at first directory level of pen drive*

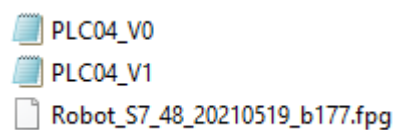

Example of software files

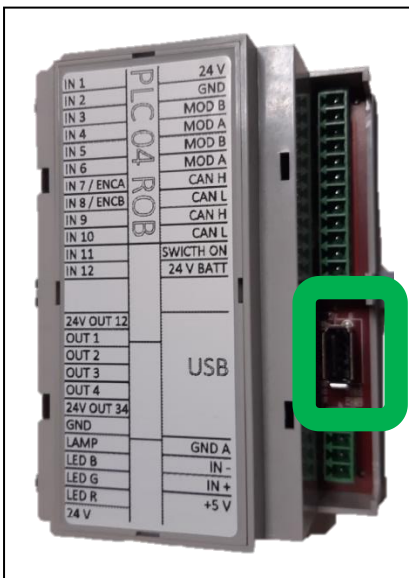
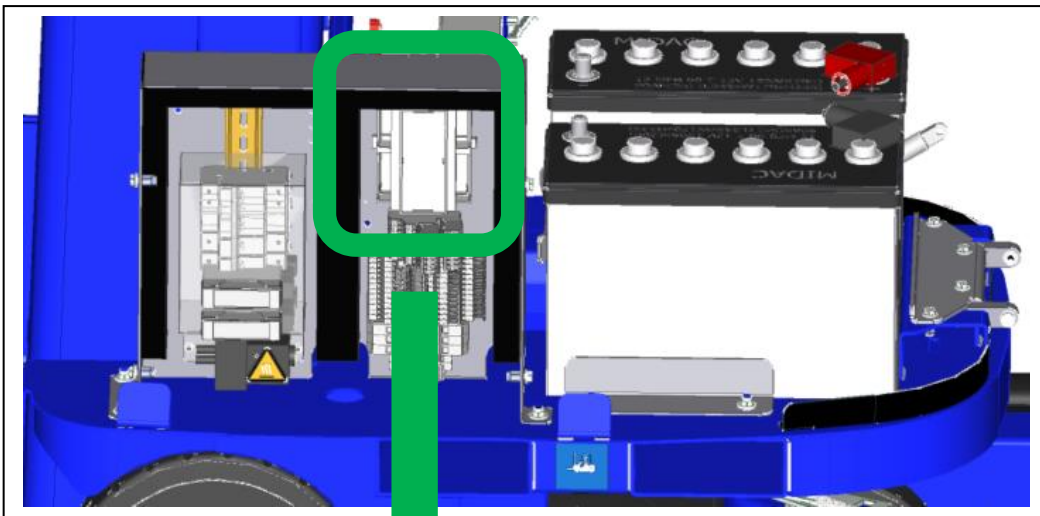

USB Port

WHITE LED = plc OK

- With the machine off, insert the USB key into the appropriate port
- Turn on the machine
- The LED next to the USB port emits a blue flash during the software download
- Once the download has been completed successfully, the LED turns flashing white or red in the event of an alarm
- Remove the USB key

- Check that you have all DIP SWITCHES ON and only N.2 OFF

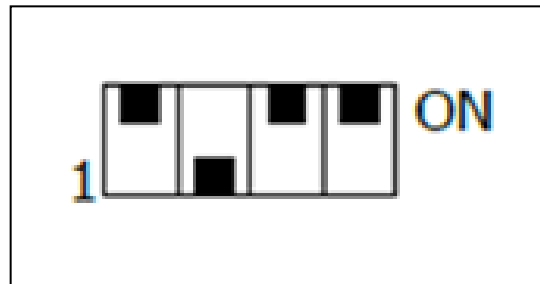
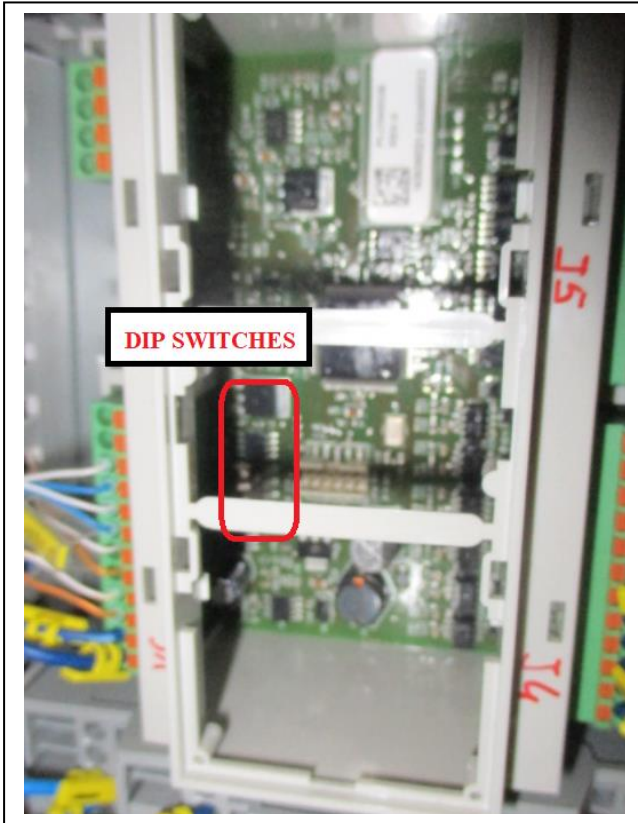

Write the MOTORS parameters

- For the modification the password 6161 is required



- Press on



Press

to write the panel parameters to the memory

The "W" button becomes **RED** to indicate the writing then becomes **GREEN** as confirmation of the end of writing

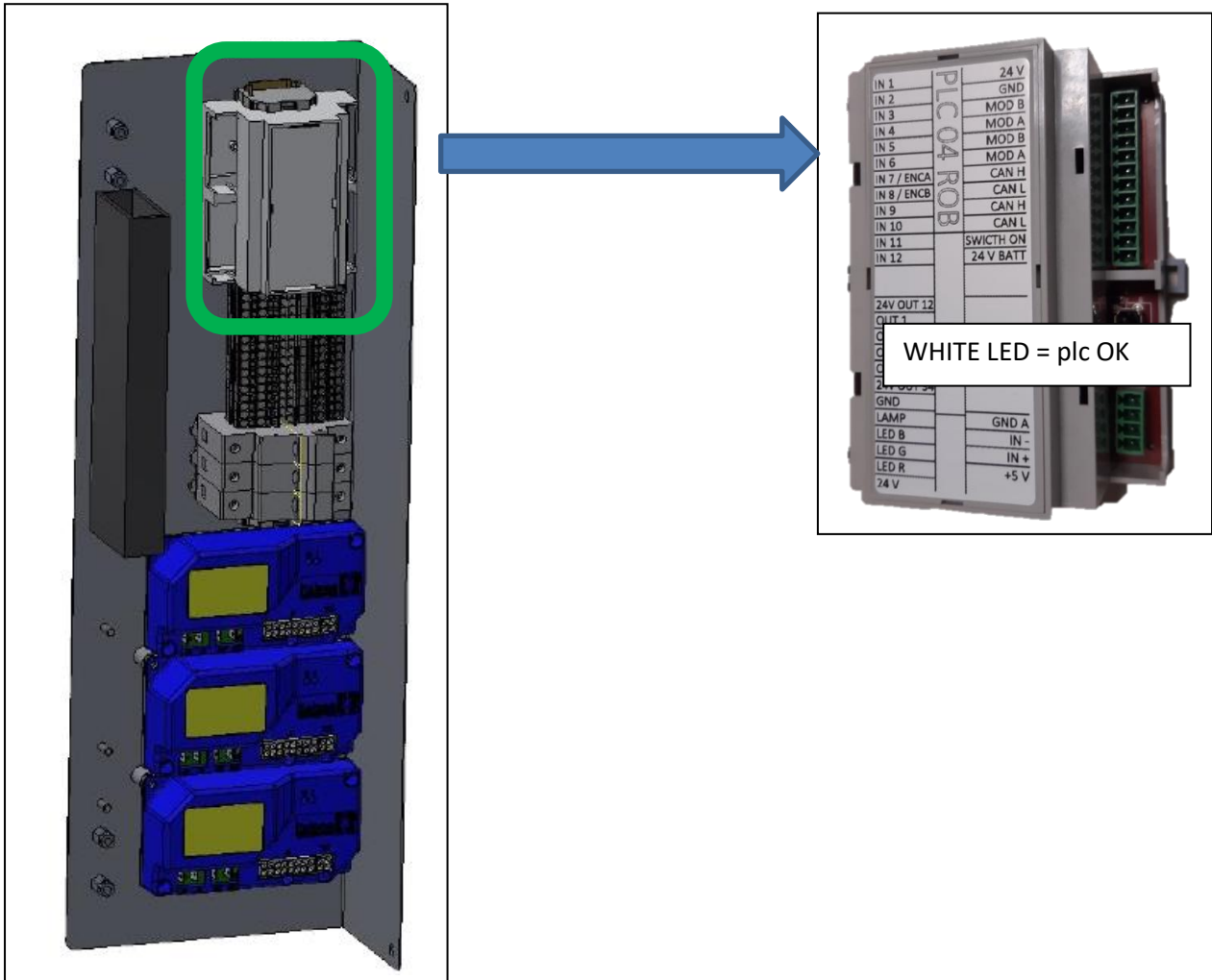
PLC BOARD mounted on the carriage (U550)

- With the machine off, insert the USB key into the appropriate port
- Turn on the machine
- The LED next to the USB port emits a blue flash during the software download
- Once the download has been completed successfully, the LED turns flashing white or red in the event of an alarm
- Remove the USB key

 Norm. Tecn. 60.2.109 rev. 00	TECHNICAL DOCUMENTATION ROBOT S7	March 2022	Rev.07
	ENGLISH	Pag. 70 / 93	

- Check that you have all DIP SWITCHES ON

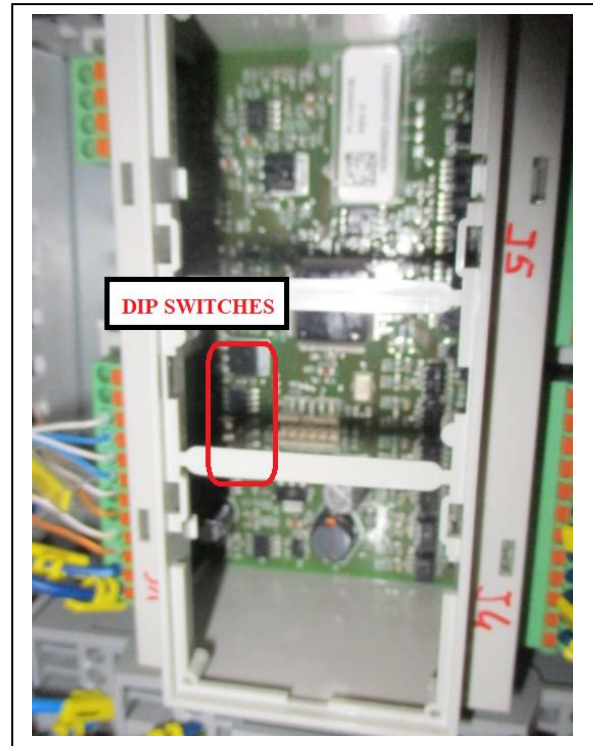
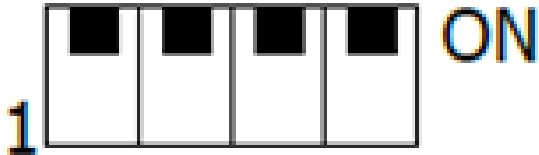

Write the CARRIAGE parameters



- For the modification the password 6161 is required



- Press on



Press  to write the panel parameters to the memory

The "W" button becomes **RED** to indicate the writing then becomes **GREEN** as confirmation of the end of writing

 Norm. Tecn. 60.2.109 rev. 00	TECHNICAL DOCUMENTATION ROBOT S7	March 2022	Rev.07
	ENGLISH	Pag. 71 / 93	

Write the MOTORS parameters



- For the modification the password 6161 is required



- Press on



Press

to write the panel parameters to the memory

The “W” button becomes **RED** to indicate the writing then becomes **GREEN** as confirmation of the end of writing

Perform the CALIBRATION of the LOAD CELL



Perform the VARIABLE ROPING CALIBRATION/SETTING



 Norm. Tecn. 60.2.109 rev. 00	TECHNICAL DOCUMENTATION ROBOT S7	March 2022	Rev.07
	ENGLISH	Pag. 72 / 93	

Motor DRIVERS REPLACEMENT

TRACTION MOTOR DRIVER

In the case of replacement of the traction group MOTOR + GEAR BOX + DRIVER (A201)

(code 2210300049)

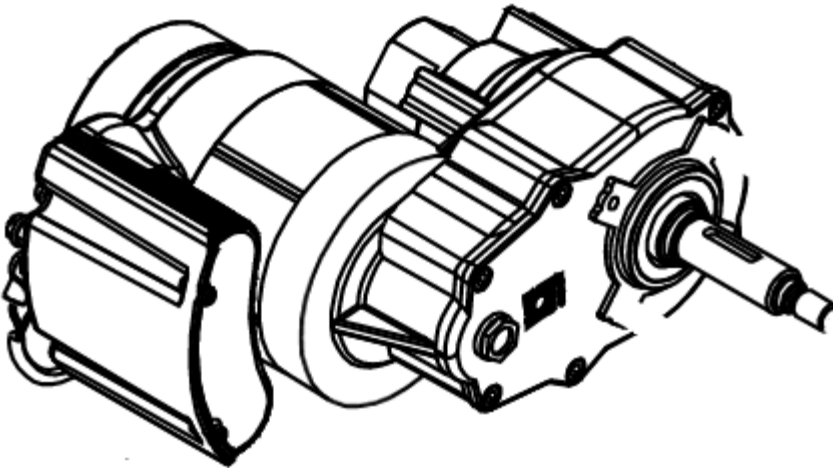

The only operation to be performed on the parameters is:

Write the MOTORS parameters

- For the modification the password 6161 is required



- Press on



Press



to write the panel parameters to the memory

The “W” button becomes **RED** to indicate the writing then becomes **GREEN** as confirmation of the end of writing

 Norm. Tecn. 60.2.109 rev. 00	TECHNICAL DOCUMENTATION ROBOT S7	March 2022	Rev.07
	ENGLISH	Pag. 73 / 93	

Up / down CARRIAGE MOTOR DRIVER

In the case of replacement of the up/down carriage group MOTOR + DRIVER (A251)
 (code 2210300068)

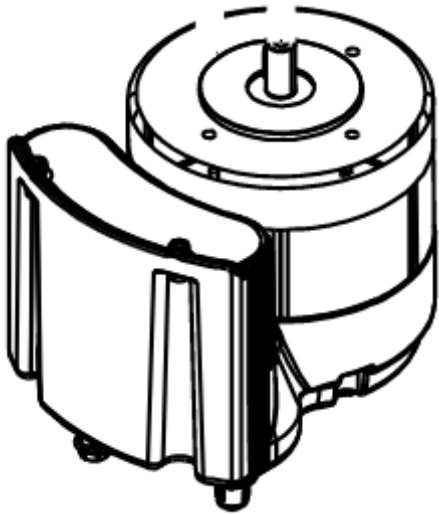

The only operation to be performed on the parameters is:

Write the MOTORS parameters

- For the modification the password 6161 is required



- Press on



Press



to write the panel parameters to the memory

The "W" button becomes **RED** to indicate the writing then becomes **GREEN** as confirmation of the end of writing

 Norm. Tecn. 60.2.109 rev. 00	TECHNICAL DOCUMENTATION ROBOT S7	March 2022	Rev.07
	ENGLISH	Pag. 74 / 93	

DRIVERS PRESENT on the FILM SPOOL CARRIAGE

3 drives with the same CODE can be mounted on the carriage (code 00L0639095)

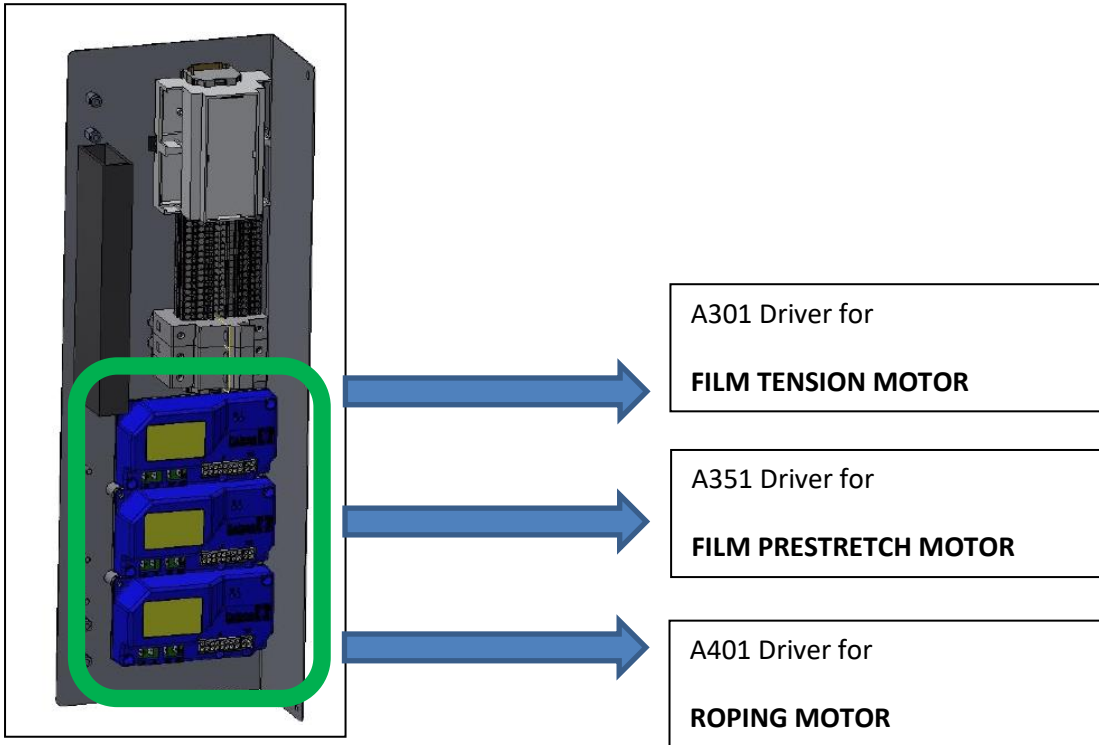

In the case of **REPLACEMENT**, the only operation to be performed on the parameters is:

Write the MOTORS parameters

- For the modification the password 6161 is required



- Press on



Press  to write the panel parameters to the memory

The "W" button becomes **RED** to indicate the writing then becomes **GREEN** as confirmation of the end of writing

 Norm. Tecn. 60.2.109 rev. 00	TECHNICAL DOCUMENTATION ROBOT S7	March 2022	Rev.07
	ENGLISH	Pag. 75 / 93	

PLC BOARDS DESCRIPTION (PLC04ROB)

PLC BOARD mounted on the ELECTRICAL BOX (U500)

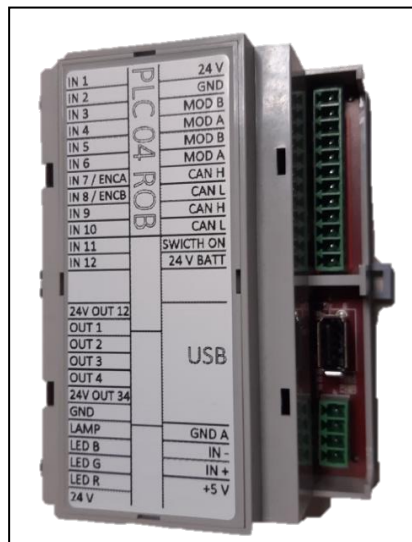
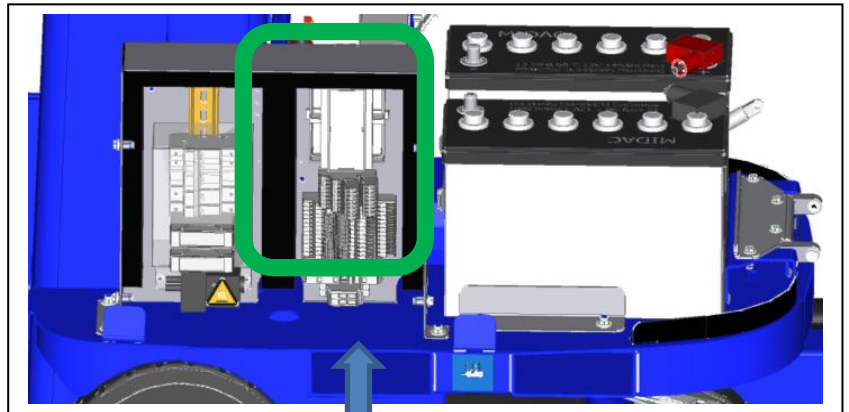

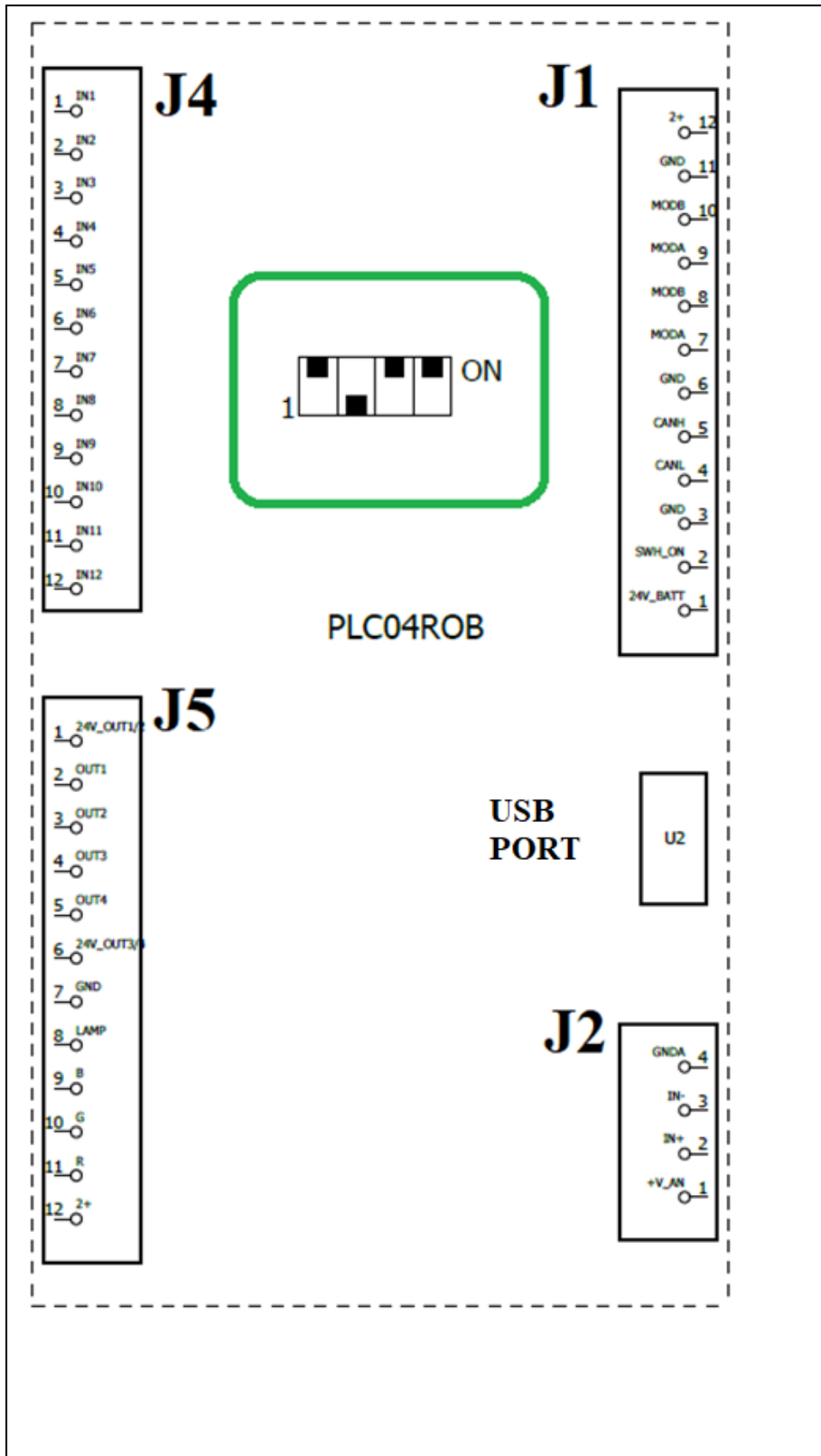

 Norm. Tecn. 60.2.109 rev. 00	TECHNICAL DOCUMENTATION ROBOT S7	March 2022	Rev.07
	ENGLISH	Pag. 77 / 93	

Connector	PIN	Signal	Meaning of the Inputs
J4	1	IN1	START Button
J4	2	IN2	Steering wheel Alarm
J4	3	IN3	RESET Button
J4	4	IN4	Emergency Button
J4	5	IN5	Emergency Bumper
J4	6	IN6	Emergency Feedback
J4	7	IN7	Traction Motor Encoder channel A
J4	8	IN8	Traction Motor Encoder channel B
J4	9	IN9	Manual Forward
J4	10	IN10	Manual Backward
J4	11	IN11	Free
J4	12	IN12	Free
Connector	PIN	Signal	Meaning of the Outputs
J5	1	24V_OUT1/2	+24VDC (for OUT1 and OUT2)
J5	2	OUT1	Auto Power OFF
J5	3	OUT2	Emergency Feedback
J5	4	OUT3	Free
J5	5	OUT4	Siren
J5	6	24V_OUT3/4	+24VDC (for OUT3 and OUT4)
J5	7	GND	Free
J5	8	LAMP	Blue Light
J5	9	B	Circulat Optical Lamp
J5	10	G	Circulat Optical Lamp
J5	11	R	Circulat Optical Lamp
J5	12	2+	Circulat Optical Lamp
Connector	PIN	Signal	Meaning of the Signals
J1	12	2+	Positive Power Supply 24VDC (+)
J1	11	GND	Negative Power Supply 0VDC (-)
J1	10	MODB	Communication with Touch Screen
J1	9	MODA	Communication with Touch Screen
J1	8	MODB	Communication Carriage PLC – Batterycharger – Battery Level
J1	7	MODA	Communication Carriage PLC – Batterycharger – Battery Level
J1	6	GND	Communication with Lithium Battery (optional)
J1	5	CANH	Communication with Lithium Battery (optional)
J1	4	CANL	Communication with Traction Driver
J1	3	GND	Communication with Traction Driver
J1	2	SWH_ON	Free
J1	1	24V_BATT	Free
Connector	PIN	Signal	Meaning of the Signals
J2	4	GNDA	Free
J2	3	IN-	Free
J2	2	IN+	Free
J2	1	+V_AN	Free

PLC BOARD mounted on the CARRIAGE (U550)

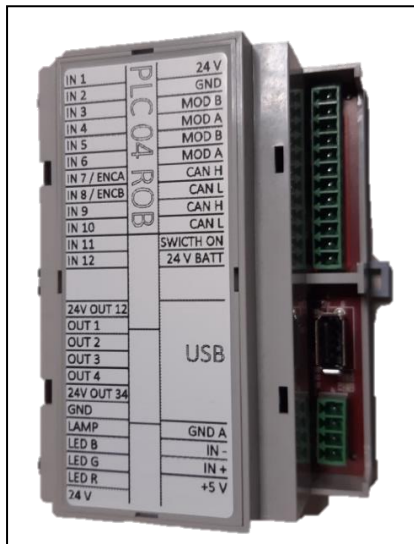
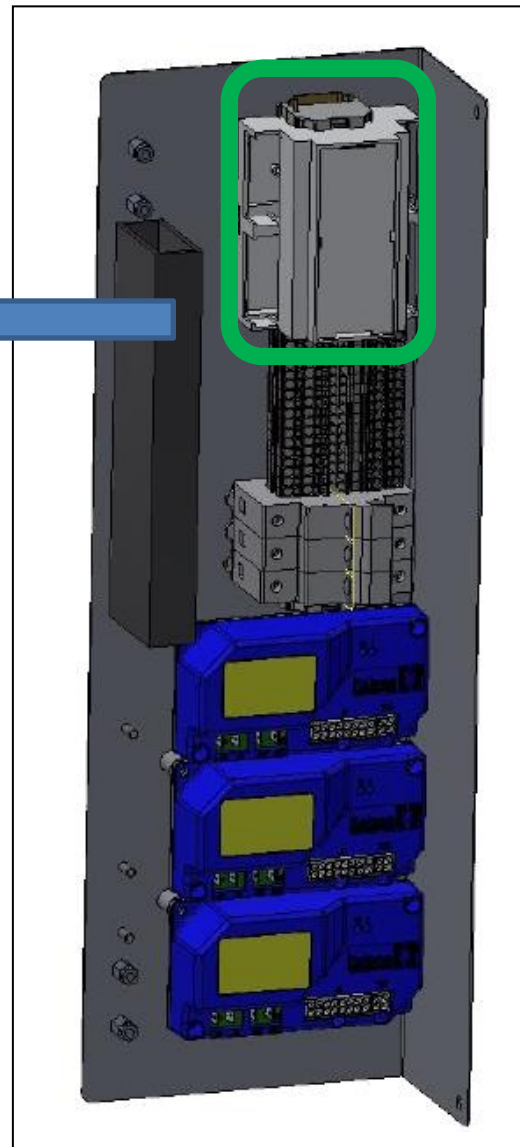

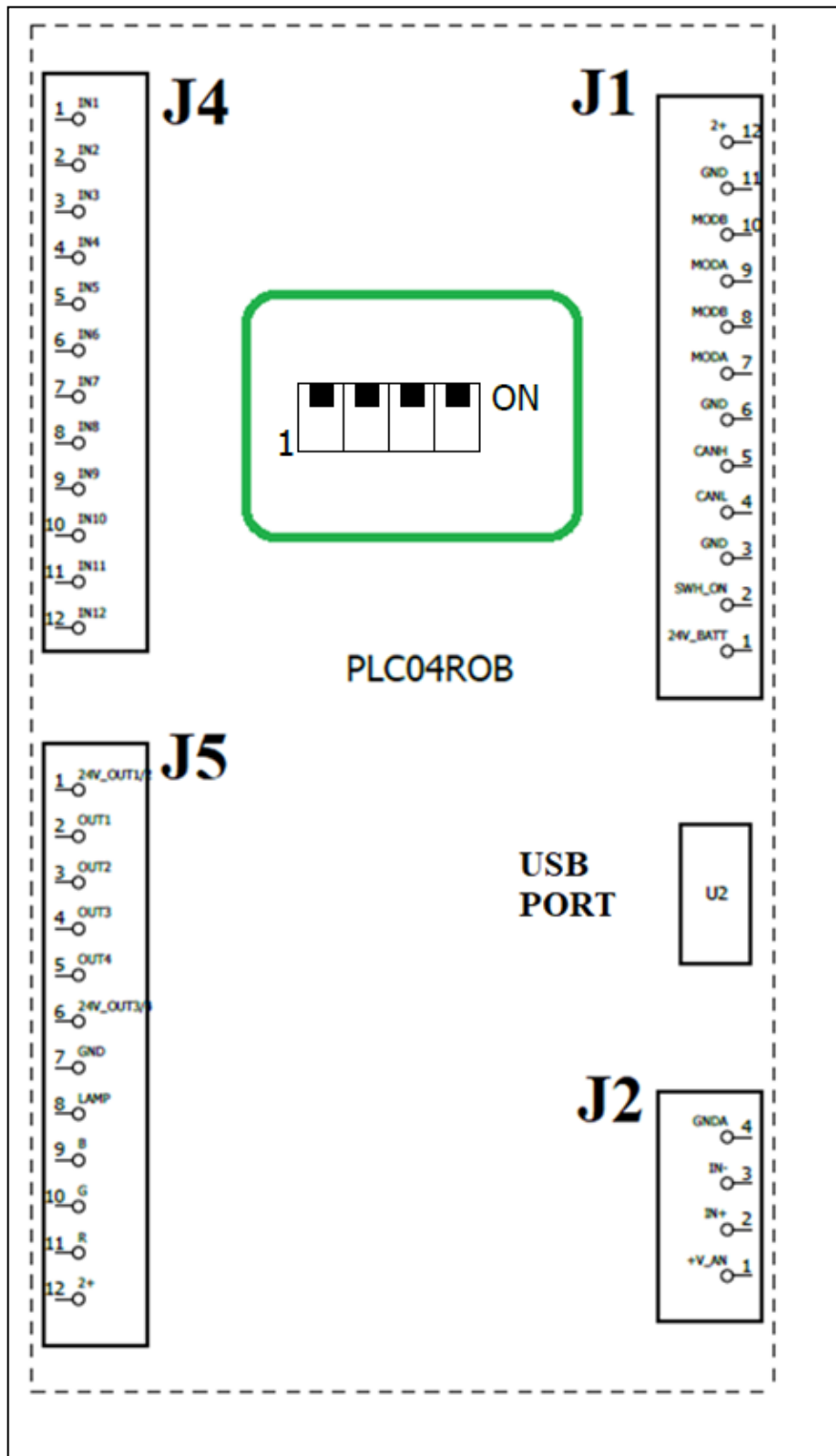

Connector	PIN	Signal	Meaning of the Inputs
J4	1	IN1	Pallet Height Photocell
J4	2	IN2	Unwinding Film Sensor (optional)
J4	3	IN3	Unwinding Film Button
J4	4	IN4	Top Microswitch
J4	5	IN5	Bottom Microswitch
J4	6	IN6	Carriage Door Opening
J4	7	IN7	Top Roping (optional)
J4	8	IN8	Bottom Roping (optional)
J4	9	IN9	Carriage Casing Opening
J4	10	IN10	Free
J4	11	IN11	Free
J4	12	IN12	Free
Connector	PIN	Signal	Meaning of the Outputs
J5	1	24V_OUT1/2	+24VDC (for OUT1 and OUT2)
J5	2	OUT1	Free
J5	3	OUT2	Film Cut (optional)
J5	4	OUT3	Driver Enable
J5	5	OUT4	Free
J5	6	24V_OUT3/4	+24VDC (for OUT3 and OUT4)
J5	7	GND	Free
J5	8	LAMP	Free
J5	9	B	Free
J5	10	G	Free
J5	11	R	Free
J5	12	2+	Free
Connector	PIN	Signal	Meaning of the Signals
J1	12	2+	Positive Power Supply 24VDC (+)
J1	11	GND	Negative Power Supply 0VDC (-)
J1	10	MODB	Communication BOX PLC – Battery charger – Battery Level
J1	9	MODA	Communication BOX PLC – Battery charger – Battery Level
J1	8	MODB	Free
J1	7	MODA	Free
J1	6	GND	Communication Roping Driver (optional)
J1	5	CANH	Communication Roping Driver (optional)
J1	4	CANL	Communication Carriage Motors Drivers (P3GS / PVS)
J1	3	GND	Communication Carriage Motors Drivers (P3GS / PVS)
J1	2	SWH_ON	Free
J1	1	24V_BATT	Free
Connector	PIN	Signal	Meaning of the Signals
J2	4	GNDA	Load Cell
J2	3	IN-	Load Cell
J2	2	IN+	Load Cell
J2	1	+V_AN	Load Cell

 Norm. Tecn. 60.2.109 rev. 00	TECHNICAL DOCUMENTATION ROBOT S7	March 2022	Rev.07
ENGLISH		Pag. 81 / 93	

CHECK CORRECT POSITION OF THE BOTTOM CARRIAGE POSITION CAM

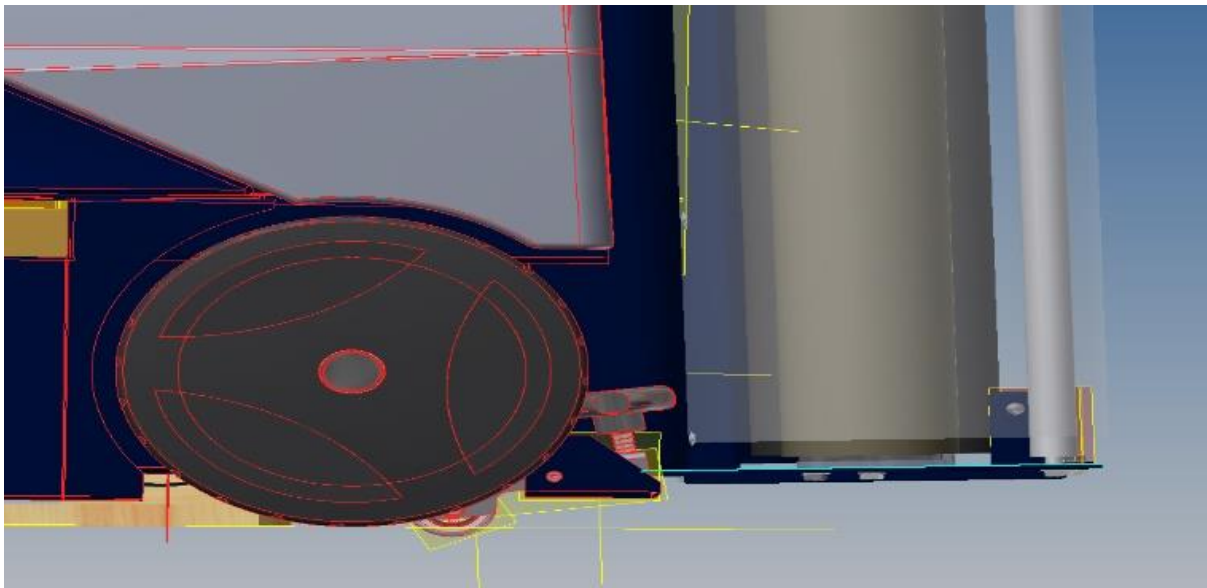

The bottom cam must be positioned so that the bottom plate of the carriage frame at the bottom stop is **15 mm from the ground**.

The measurement must be taken at the lowest point, therefore towards the mast.

 <p>Norm. Tecn. 60.2.109 rev. 00</p>	<p>TECHNICAL DOCUMENTATION ROBOT S7</p>	<p>March 2022</p>	<p>Rev.07</p>
<p>ENGLISH</p>		<p>Pag. 82 / 93</p>	

ALARM LIST

Emergency Button Alarm E1001



Emergency button pressed



Emergency button pressed many times
during working cycle

 Norm. Tecn. 60.2.109 rev. 00	TECHNICAL DOCUMENTATION ROBOT S7	March 2022	Rev.07
	ENGLISH	Pag. 83 / 93	

Emergency Bumper Alarm E1002

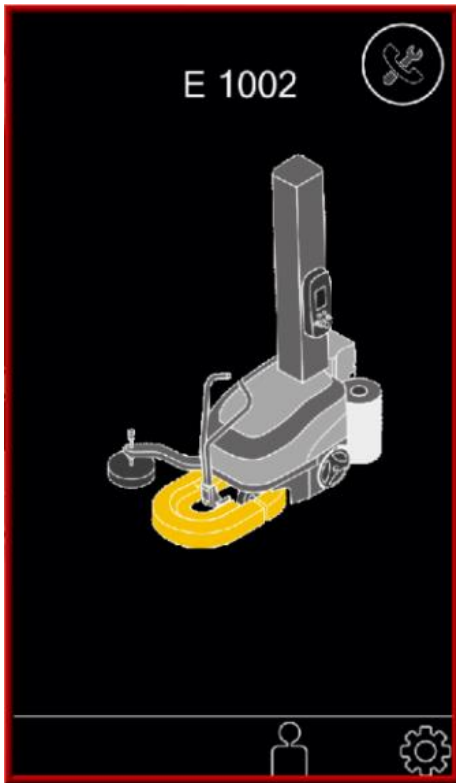

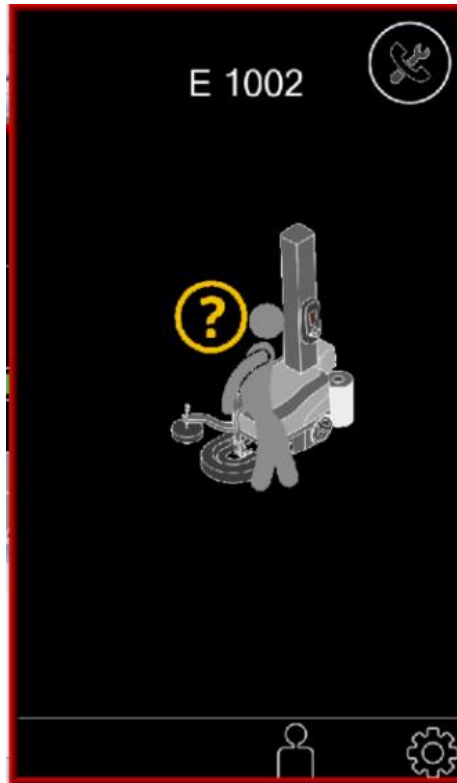

Bumper pressed

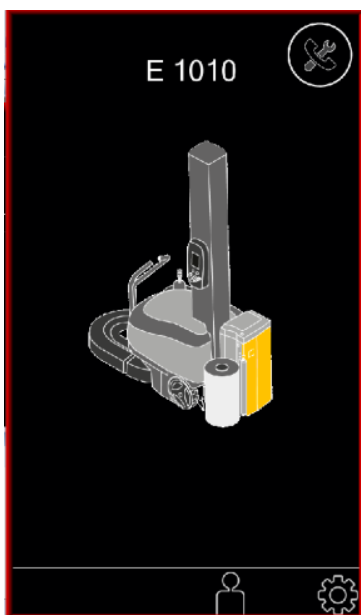

Bumper pressed many times during working cycle

Open Carriage Alarm E1010



 <p>Norm. Tecn. 60.2.109 rev. 00</p>	<p>TECHNICAL DOCUMENTATION ROBOT S7</p>	<p>March 2022</p>	<p>Rev.07</p>
<p>ENGLISH</p>		<p>Pag. 84 / 93</p>	

Battery in Charge Alarm E1090

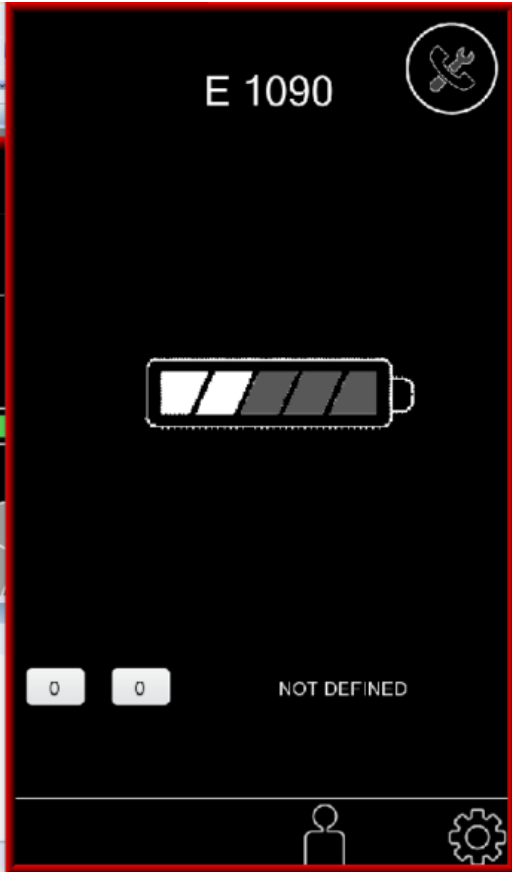

Battery on charge (with INFO charging)

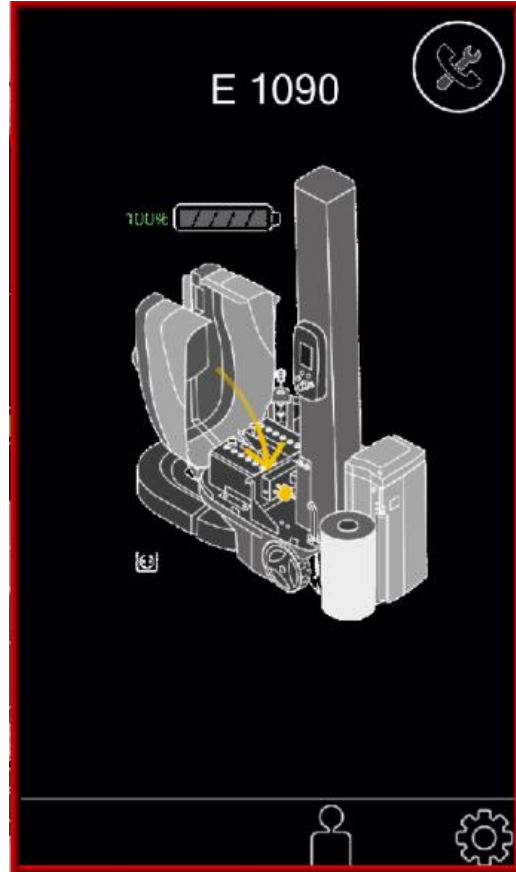

Charging completed successfully

Motor Alarms E3x10

MOTOR ALARM

E3110 MOTOR1	2 : ENCODER
E3210 MOTOR2	5 : OVERTEMPERATURE
E3310 MOTOR3	7 : OVER CURRENT
E3410 MOTOR4	11: OVERCURRENT I2T
E3510 MOTOR5	15 : PHASE FAIL

E3110 Traction Motor	MOT 1
E3210 Carriage up/down Motor	MOT 2
E3310 Film Tension Motor	MOT 3
E3410 Film Prestretch Motor	MOT 4
E3510 Roping Motor e	MOT 5

Next to each motori is present
The motor alarm code:

- 2 - ENCODER
- 5 – OVERTEMPERATURE
- 6 – SHORT CIRCUIT
- 7 – OVERCURRENT
- 8 – PRECHARGE
- 9 – UNDERVOLTAGE
- 10 – OVERVOLTAGE
- 11 – OVERCURRENT I2T
- 12 - DISABLE
- 13 – KEY OFF
- 14 – EEPROM
- 15 – PHASE FAIL
- 16 – GENERIC
- 17 – WRONG PARAMETERS
- 18 – NO PARAMETERS

 <p>Norm. Tecn. 60.2.109 rev. 00</p>	<p>TECHNICAL DOCUMENTATION ROBOT S7</p>	<p>March 2022</p>	<p>Rev.07</p>
<p>ENGLISH</p>		<p>Pag. 86 / 93</p>	

TRACTION Alarm E61xx

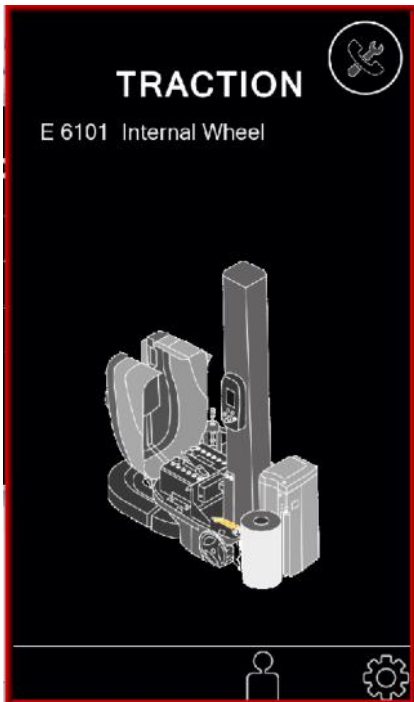

E6101 External wheel raised

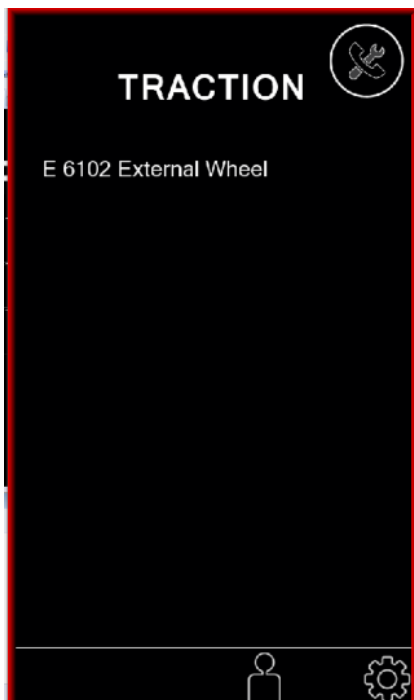

E6102 No signal traction motor encoder

 <p>Norm. Tecn. 60.2.109 rev. 00</p>	<p>TECHNICAL DOCUMENTATION ROBOT S7</p>	<p>March 2022</p>	<p>Rev.07</p>
	<p>ENGLISH</p>	<p>Pag. 87 / 93</p>	

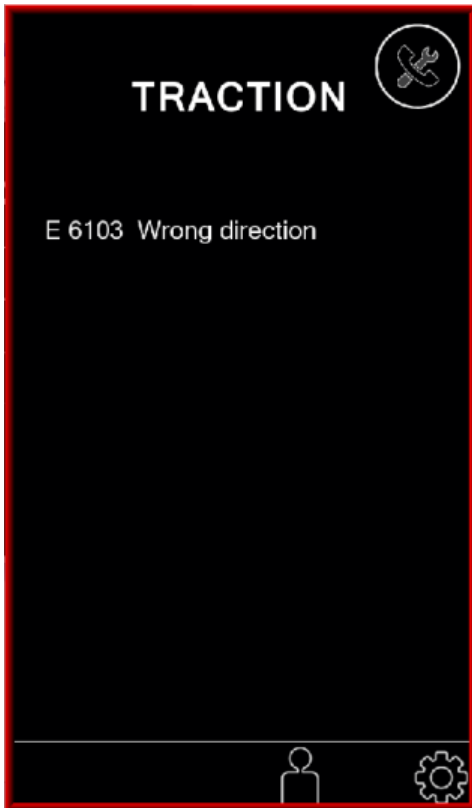

E6103 Inverted inner wheel
(steering system problem)

 Norm. Tecn. 60.2.109 rev. 00	TECHNICAL DOCUMENTATION ROBOT S7	March 2022	Rev.07
	ENGLISH	Pag. 88 / 93	

LIFTING group (up/down carriage) Alarm E62xx

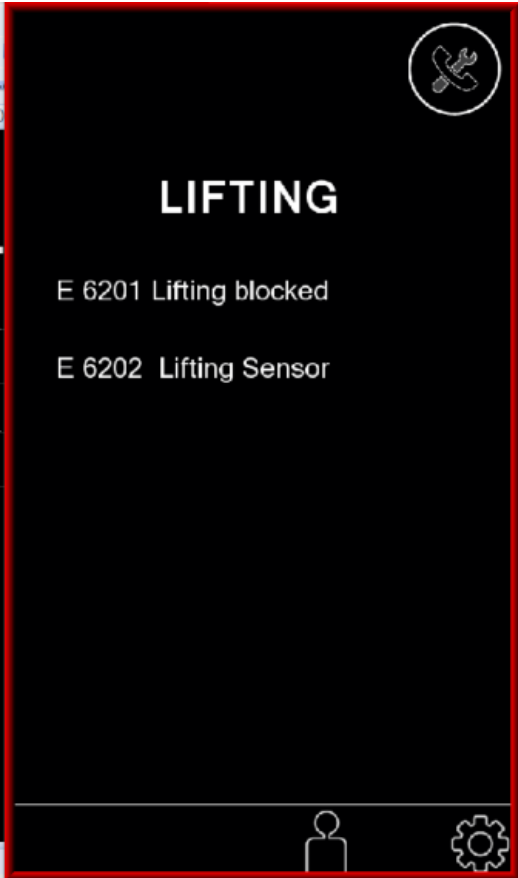

E6201 Lifting blocked Alarm

E6202 Lifting Sensors Alarm

(High and low limit switches active at the same time)

 <p>Norm. Tecn. 60.2.109 rev. 00</p>	<p align="center">TECHNICAL DOCUMENTATION ROBOT S7</p>	<p align="center">March 2022</p>	<p align="center">Rev.07</p>
	<p align="center">ENGLISH</p>	<p align="center">Pag. 89 / 93</p>	

FILM Alarms E63xx

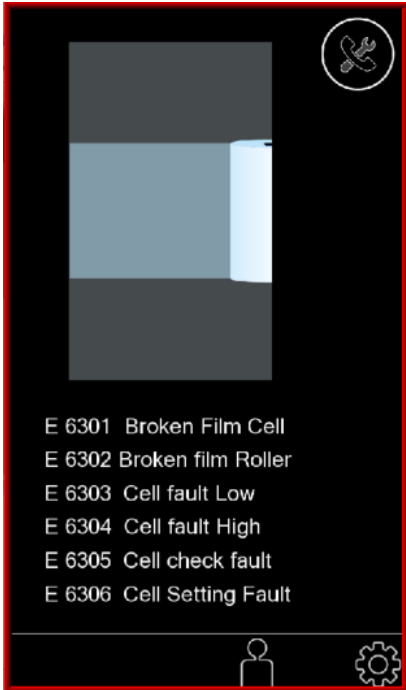

E6301 Film break Alarm detected by load cell sensor

E6302 Film break Alarm detected by film unwinding sensor

E6303 Load cell sensor fault, value too low

E6304 Load cell sensor fault, value too high

E6305 Load cell sensor fault, non-compliant no-load value

E6306 Load cell sensor setting fault

E6307 Load cell calibration not performed

 Norm. Tecn. 60.2.109 rev. 00	TECHNICAL DOCUMENTATION ROBOT S7	March 2022	Rev.07
	ENGLISH	Pag. 90 / 93	

ROPING GROUP Alarms E64xx



E6401 Roping motor Alarm

E6402 Roping sensors Alarm

(finecorsa alto e basso attivi contemporaneamente)

E6403 Roping Blocked Alarm

E6404 Roping setting not performed alarm

(perform calibration/setting of the roping device)

Alarm E68xx

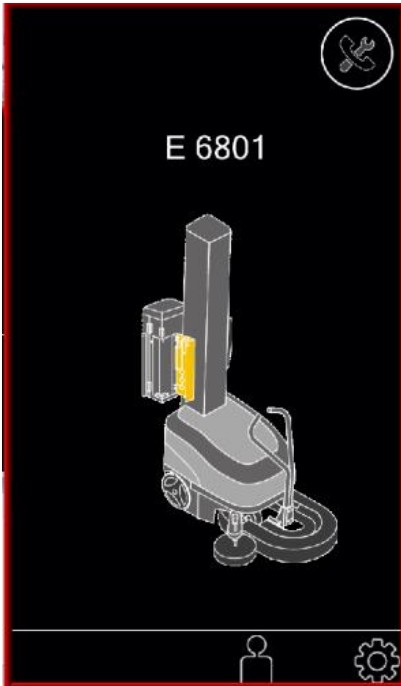

E6801 Carriage electrical panel open

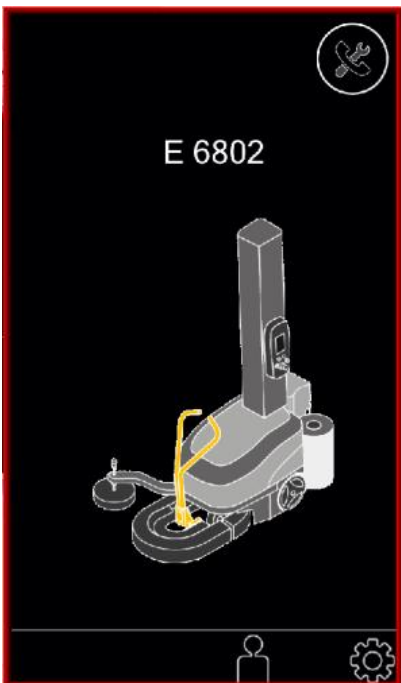

E6802 Forward steering wheel Alarm

 <p>Norm. Tecn. 60.2.109 rev. 00</p>	TECHNICAL DOCUMENTATION ROBOT S7	March 2022	Rev.07
	ENGLISH	Pag. 92 / 93	

Communication alarms E80xx

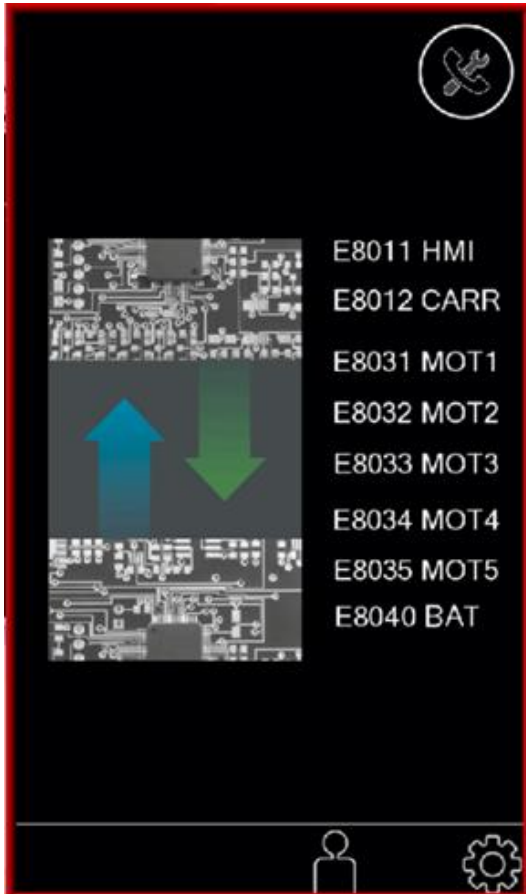

- E8011 HMI Communication Alarm**
- E8012 Carriage PLC Communication Alarm**
- E8031 Traction motor Communication Alarm**
- E8032 Lifting motor Communication Alarm**
- E8033 Film unwinding motor Communication Alarm**
- E8034 Prestretch motor Communication Alarm**
- E8035 Roping motor Communication Alarm**
- E8040 Battery Communication Alarm**

 <p>Norm. Tecn. 60.2.109 rev. 00</p>	<p>TECHNICAL DOCUMENTATION ROBOT S7</p>	<p>March 2022</p>	<p>Rev.07</p>
<p>ENGLISH</p>		<p>Pag. 93 / 93</p>	

Alarms E9xxx

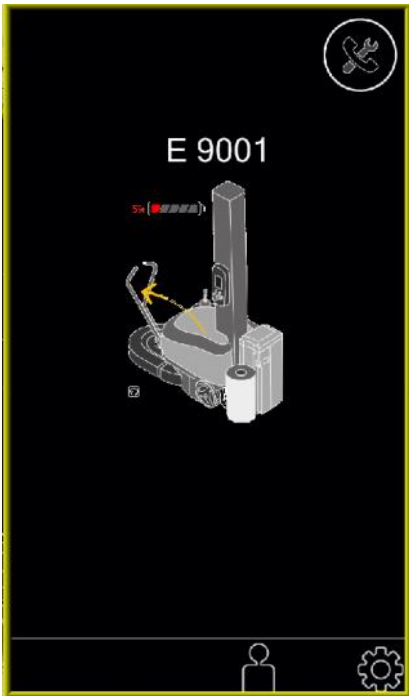

E9001 Low battery warning

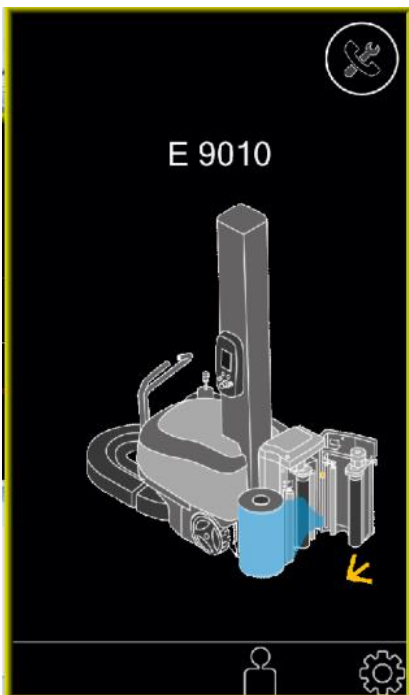

E9010 Change of the roping mode (from top or from bottom)