

TECHNICAL DOCUMENTATION

ROBOT S7

Stop&Go



 Norm. Tecn. 60.2.113 rev. 00	TECHNICAL DOCUMENTATION ROBOT S7– Stop&Go	September 2022	Rev.04
	ENGLISH	Pag. 2 / 124	

60.2.109 rev. 01 – S7 standard -

Date	Revision	Detailed revision reasons	Issue-Checked by
06/2022	00	First issue	<i>Fabrizio BALDININI</i>
06/2022	01	Update on Lithium batteries	<i>Fabrizio BALDININI</i>
07/2022	02	Various changes to parameters, procedures, warnings ...	<i>Fabrizio BALDININI</i>
07bis/2022	03	New Lithium battery	<i>Fabrizio BALDININI</i>
09/2022	04	Minimum height detectable by the Laser Scanner	<i>Fabrizio BALDININI</i>

 Norm. Tecn. 60.2.113 rev. 00	TECHNICAL DOCUMENTATION ROBOT S7– Stop&Go	September 2022	Rev.04
	ENGLISH	Pag. 3 / 124	

60.2.109 rev. 01 – S7 standard -

Index

INTERVENTION AREA FRONT PROTECTION SYSTEM (LASER SCANNER)	8
LASER SCANNER OPERATION and STOP&GO	9
STOP and RESTART.....	9
FULL STOP	9
CARRIAGES SCHEMATIC DESCRIPTION and FILM PATH	10
FRD CARRIAGE.....	10
FR CARRIAGE.....	11
FILM PATH in FRD and FR carriages	12
P3GS CARRIAGE	13
PVS CARRIAGE	14
FILM PATH in P3GS and PVS carriages	15
OPERATOR PANEL DESCRIPTION.....	16
BATTERY STATE DESCRIPTION.....	17
CYCLE PARAMETERS DESCRIPTION	18

 Norm. Tecn. 60.2.113 rev. 00	TECHNICAL DOCUMENTATION ROBOT S7– Stop&Go	September 2022	Rev.04
	ENGLISH	Pag. 4 / 124	

60.2.109 rev. 01 – S7 standard -

QUICK MENU24

PASSWORDS MANAGEMENT25

 Password for VISION SERVICE area26

 RESET of the Customer Manager password to 1111.....27

MANUAL OPERATIONS ON THE CARRIAGE28

MANUAL OPERATION ON THE STEERING BAR - the steering bar must be DOWN -29

 LED SIGNALING OF THE STEERING BAR BUTTONS.....30

FAST FORWARD in Manual.....31

CIRCULAR LED MEANING32

CYCLE SELECTION33

SERVICE PAGES34

COUNTERS.....35

VARIOUS SETTINGS AND INFORMATION36

SERVICE PAGES37

CONFIGURATION PARAMETERS38

 ACCESS to CONFIGURATION PARAMETERS39

 CONFIGURATION PARAMETERS DEFAULT40

 LIST of the CONFIGURATION PARAMETERS41

 ACCESS to CARRIAGE PARAMETERS43

 DEFAULT of the CARRIAGE PARAMETERS.....43

 LIST of the CARRIAGE PARAMETERS44

 ACCESS to MOTOR PARAMETERS45

 MOTOR PARAMETERS DEFAULT45

 LIST of the MOTOR PARAMETERS46

 Norm. Tecn. 60.2.113 rev. 00	TECHNICAL DOCUMENTATION ROBOT S7– Stop&Go	September 2022	Rev.04
	ENGLISH	Pag. 5 / 124	

60.2.109 rev. 01 – S7 standard -

LOAD CELL CALIBRATION47

VARIABLE ROPING CALIBRATION/SETTING.....48

CARRIAGE TEST CYCLE.....49

COMUNICATION CHECK between DEVICES.....50

R-CONNECT MODULE REGISTRATION.....51

PRODUCT HEIGHT DETECTION PHOTOCELL CALIBRATION52

 STANDARD PHOTOCELL (for clear products)52

 PHOTOCELL FOR BLACK PRODUCTS S6252

 READING DISTANCE ADJUSTMENT53

 PHOTOCELL FOR BLACK PRODUCTS S6554

 R-CONNECT PHOTOCELL (only on P3GS PVS carriages)54

“POWER SAVE” FUNCTION55

AUTO POWER OFF FUNCTION55

LITHIUM BATTERY AUTO POWER OFF55

BATTERY CHARGER SETTINGS56

 CHECK THE CURRENT DELIVERED in the CHARGE PHASE57

 MEANING OF THE LEDS of the battery charger57

BATTERYCHARGERS ALARMS58

“RECOVERY” CHARGING CURVE Lead Acid Battery59

“RECOVERY” CHARGING CURVE Lithium Battery60

COMPARISON BETWEEN LITHIUM BATTERIES AND LEAD ACID BATTERIES62

NEW LITHIUM BATTERY with Keypad (from June 2022)65

 Norm. Tecn. 60.2.113 rev. 00	TECHNICAL DOCUMENTATION ROBOT S7– Stop&Go	September 2022	Rev.04
	ENGLISH	Pag. 6 / 124	

60.2.109 rev. 01 – S7 standard -

PROCEDURES FOR REPLACEMENT, SOFTWARE LOADING AND CALIBRATION OF ELECTRONIC BOARDS.....	66
TOUCH SCREEN PANEL	66
New Installation.....	68
Software Update	73
PLC BOARD mounted in the electrical panel (U500).....	76
PLC BOARD mounted on the carriage (U550)	79
Motor DRIVERS REPLACEMENT	82
TRACTION MOTOR DRIVER.....	82
Up / down CARRIAGE MOTOR DRIVER.....	84
DRIVERS PRESENT on the FILM SPOOL CARRIAGE	85
REAR SAFETY SYSTEM COMPONENTS (laser scanner).....	86
LASER SCANNER.....	86
SAFETY CONTROL UNIT.....	87
PLC BOARDS DESCRIPTION (PLC04ROB).....	88
PLC BOARD mounted on the ELECTRICAL BOX (U500)	88
PLC BOARD mounted on the CARRIAGE (U550).....	91
DESCRIPTION of the LASER SCANNER - S7 - 16V -	94
SIGNALS on the LASER SCANNER - S7 - 16V -	96
LEDS	96
DISPLAY	97
DESCRIPTION of the SAFETY MODULES	98
MAIN UNIT (8 inputs / 4 single OSSDs) - A560 Mosaic M1S	98
SIGNALING LEDES - normal operation and diagnostics - M1S.....	99
I/O EXPANSION UNIT (8 inputs / 2 double OSSDs) - A564 Mosaic MI802	101
SIGNALING LEDES - normal operation and diagnostics – MI802	102
PROXIMITY SENSOR EXPANSION UNIT - A567 Mosaic MV0.....	104
SIGNALING LEDES - normal operation and diagnostics – MV0.....	105
CHECK CORRECT POSITION OF THE BOTTOM CARRIAGE POSITION CAM.....	107

 Norm. Tecn. 60.2.113 rev. 00	TECHNICAL DOCUMENTATION ROBOT S7– Stop&Go	September 2022	Rev.04
	ENGLISH	Pag. 7 / 124	

60.2.109 rev. 01 – S7 standard -

ALARM LIST	108
Emergency Button Alarm E1001	108
Laser Scanner Alarm E1003.....	109
Open Carriage Alarm E1010.....	110
Steering Bar Alarm E1050	110
Speed Alarm E1055.....	111
Laser Scanner Error E1060	111
Speed Sensors Error E1061	112
PLC Signal Error E1062.....	112
Power contactor feedback error E1063	113
Battery in Charge Alarm E1090	113
Motor Alarms E3x10.....	114
TRACTION Alarm E61xx	115
LIFTING group (up/down carriage) Alarm E62xx	117
FILM Alarms E63xx	118
ROPING GROUP Alarms E64xx	119
Alarm E68xx	120
Communication alarms E80xx	121
Alarms E9xxx.....	122
Improper battery use and charging E9030	124

 Norm. Tecn. 60.2.113 rev. 00	TECHNICAL DOCUMENTATION ROBOT S7– Stop&Go	September 2022	Rev.04
	ENGLISH	Pag. 8 / 124	

60.2.109 rev. 01 – S7 standard -

INTERVENTION AREA FRONT PROTECTION SYSTEM (LASER SCANNER)

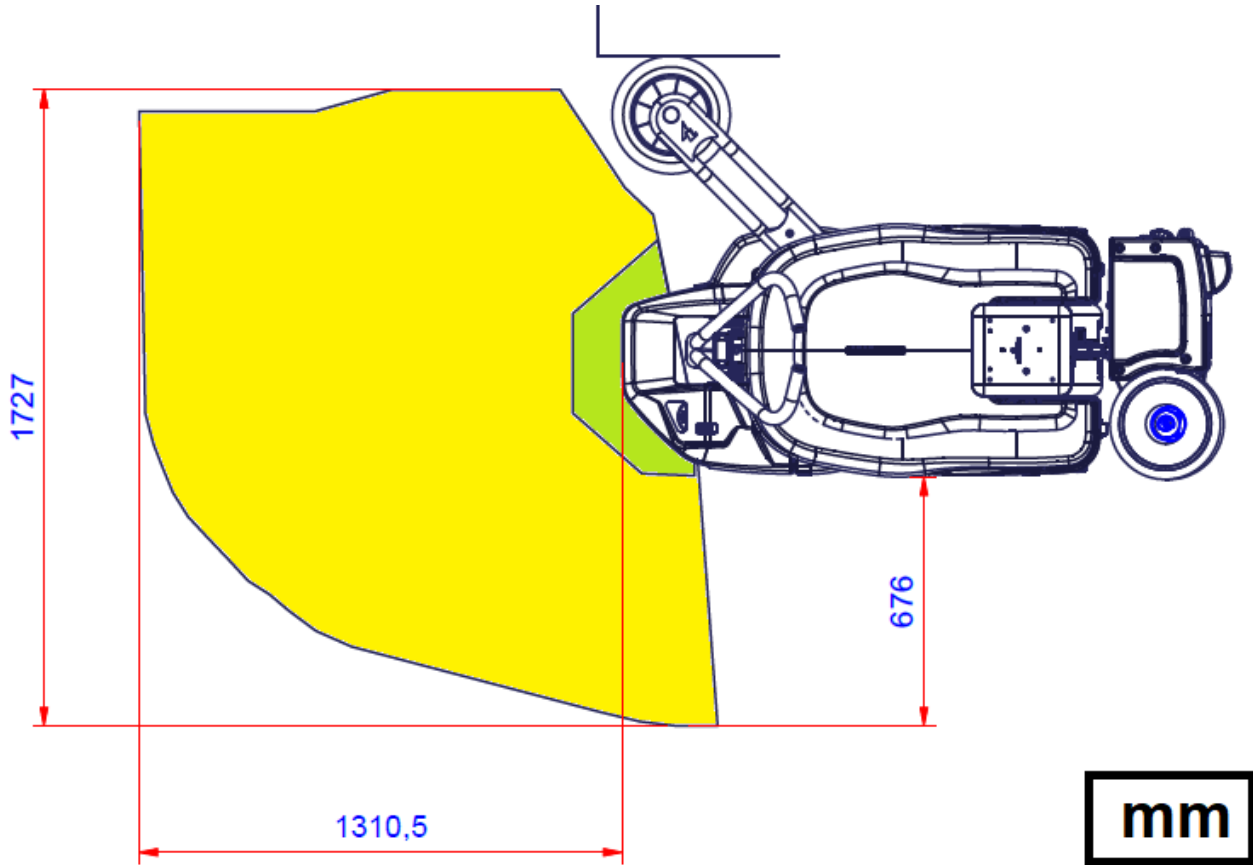

OBJECTS < 65 mm HEIGHT -----> ARE NOT DETECTED by the Laser Scanner

YELLOW AREA ---> AUTOMATIC CYCLE

GREEN AREA ---> MANUAL MOVEMENT

... ONLY with steering bar down... area of about 20 centimeters

 Norm. Tecn. 60.2.113 rev. 00	TECHNICAL DOCUMENTATION ROBOT S7– Stop&Go	September 2022	Rev.04
	ENGLISH	Pag. 9 / 124	

60.2.109 rev. 01 – S7 standard -

LASER SCANNER OPERATION and STOP&GO

STOP and RESTART

If during the wrapping cycle the ROBOT Stop&Go detects an obstacle within the YELLOW ZONE - for example in zones 1/2/3/4/5 - the robot stops.

If **within 15 SECONDS** the obstacle is eliminated then the yellow area is "free" ---> the **ROBOT RESTART**

The restart of the Robot takes place 10 SECONDS after the complete liberation of the yellow area

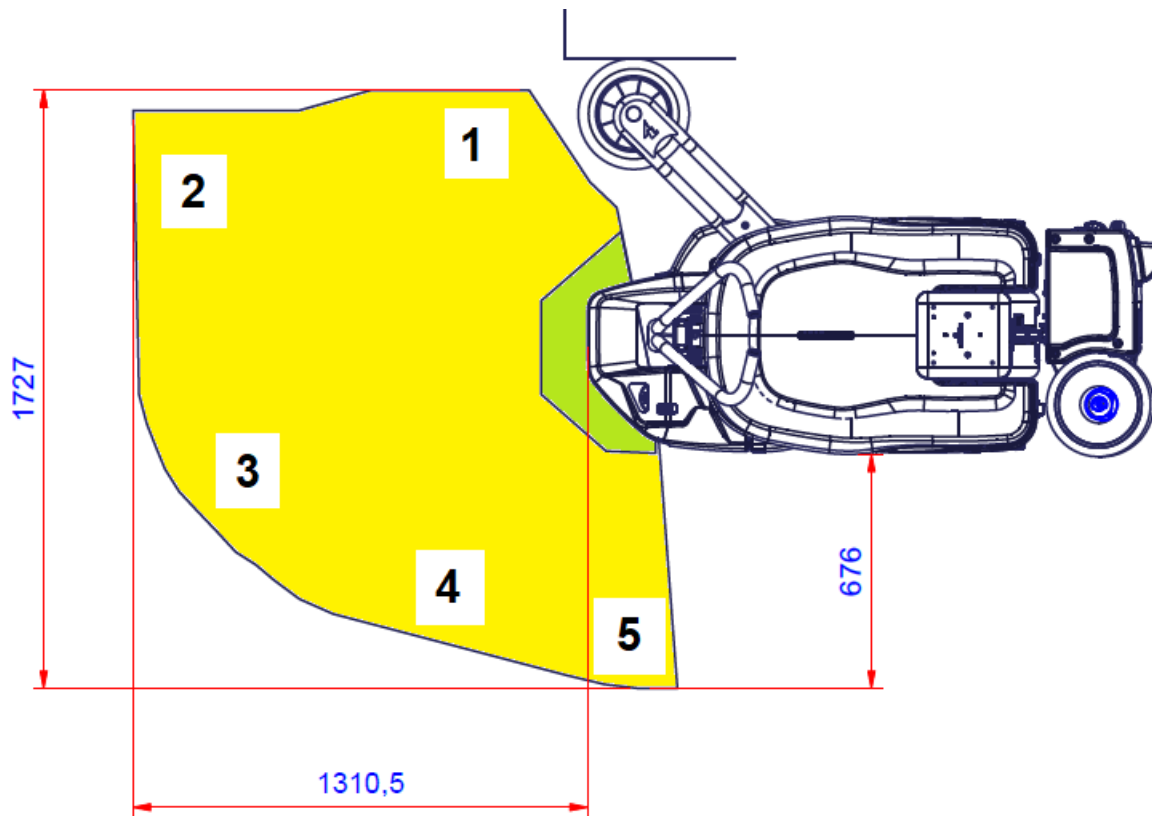

OBJECTS < 65 mm HEIGHT -----> ARE NOT DETECTED by the Laser Scanner

FULL STOP

If the obstacle is left for **more than 15 seconds**, the robot remains in alarm and **DOES NOT START** again even if the obstacle is removed and the area completely cleared

It is necessary to reset the alarm by action of the operator (pressing RESET).

60.2.109 rev. 01 – S7 standard -

CARRIAGES SCHEMATIC DESCRIPTION and FILM PATH

FRD CARRIAGE

FILM Tensioning with MECHANICAL BRAKE

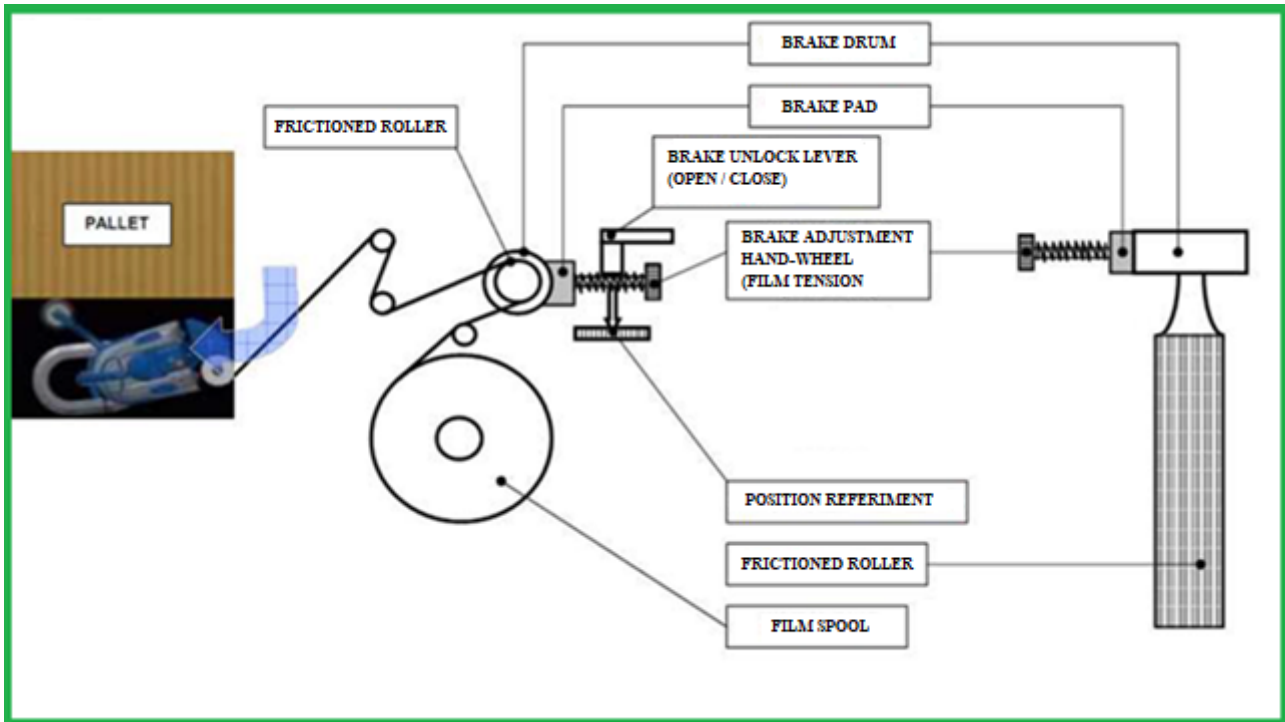

60.2.109 rev. 01 – S7 standard -

FR CARRIAGE

FILM Tensioning with ELECTROMAGNETIC BRAKE/CLUTCH

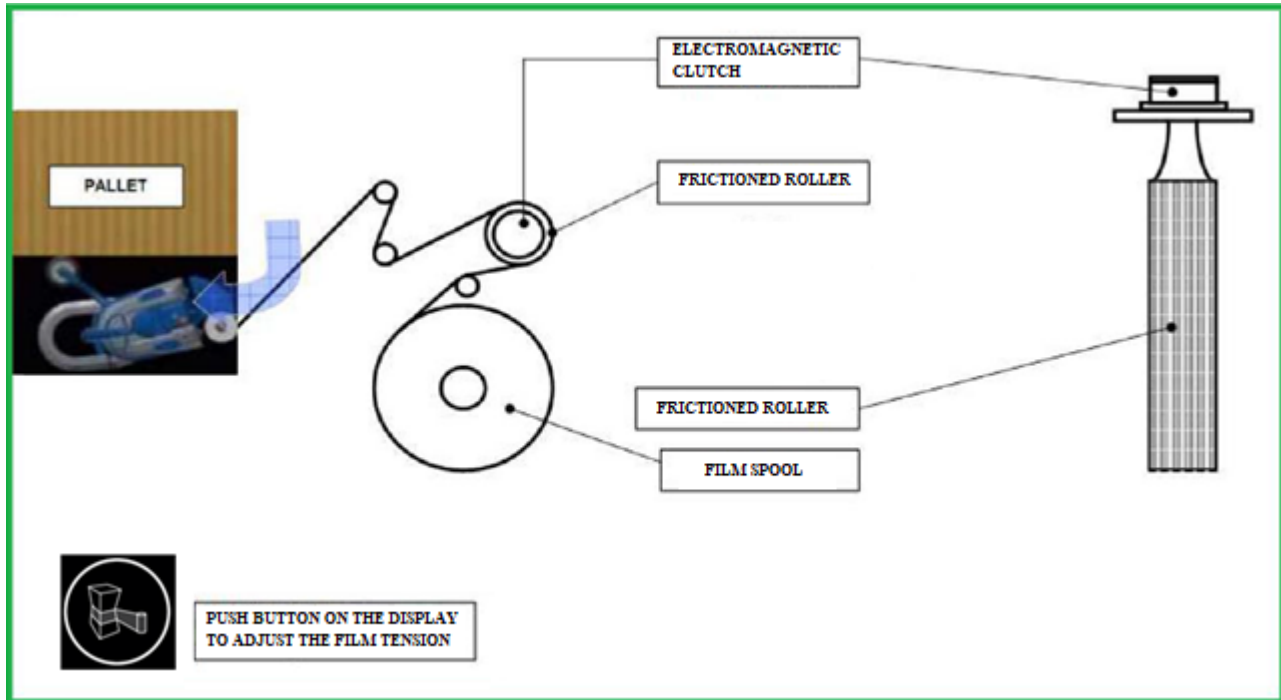

60.2.109 rev. 01 – S7 standard -

FILM PATH in FRD and FR carriages

FRD

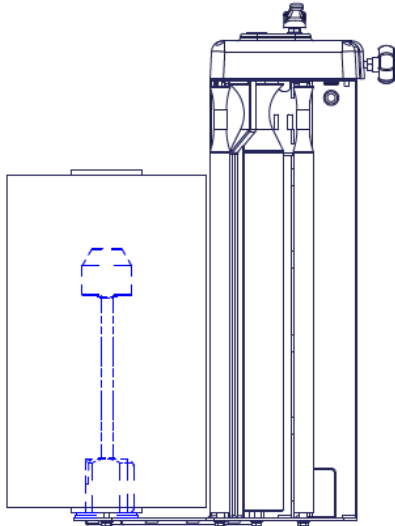

FR

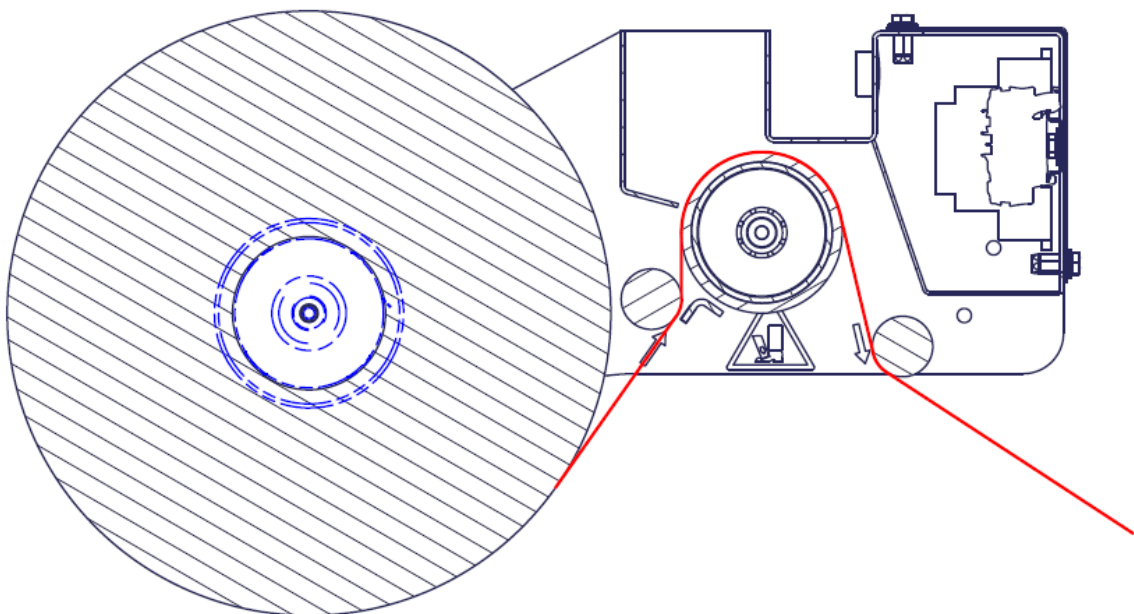
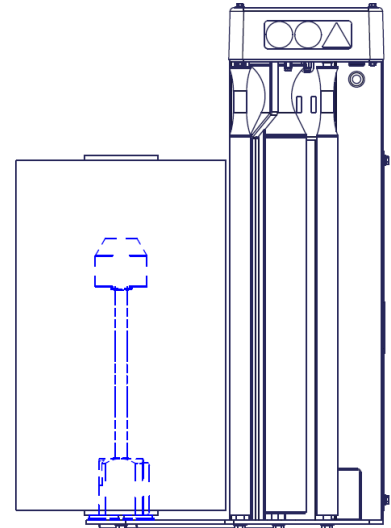

60.2.109 rev. 01 – S7 standard -

P3GS CARRIAGE

FILM Tensioning with LOAD CELL and FIXED PRESTRETCH (3 values)

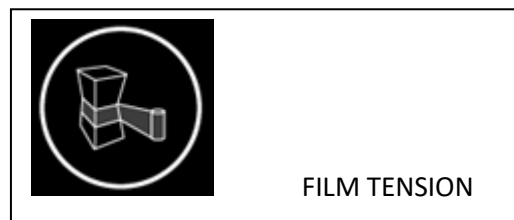
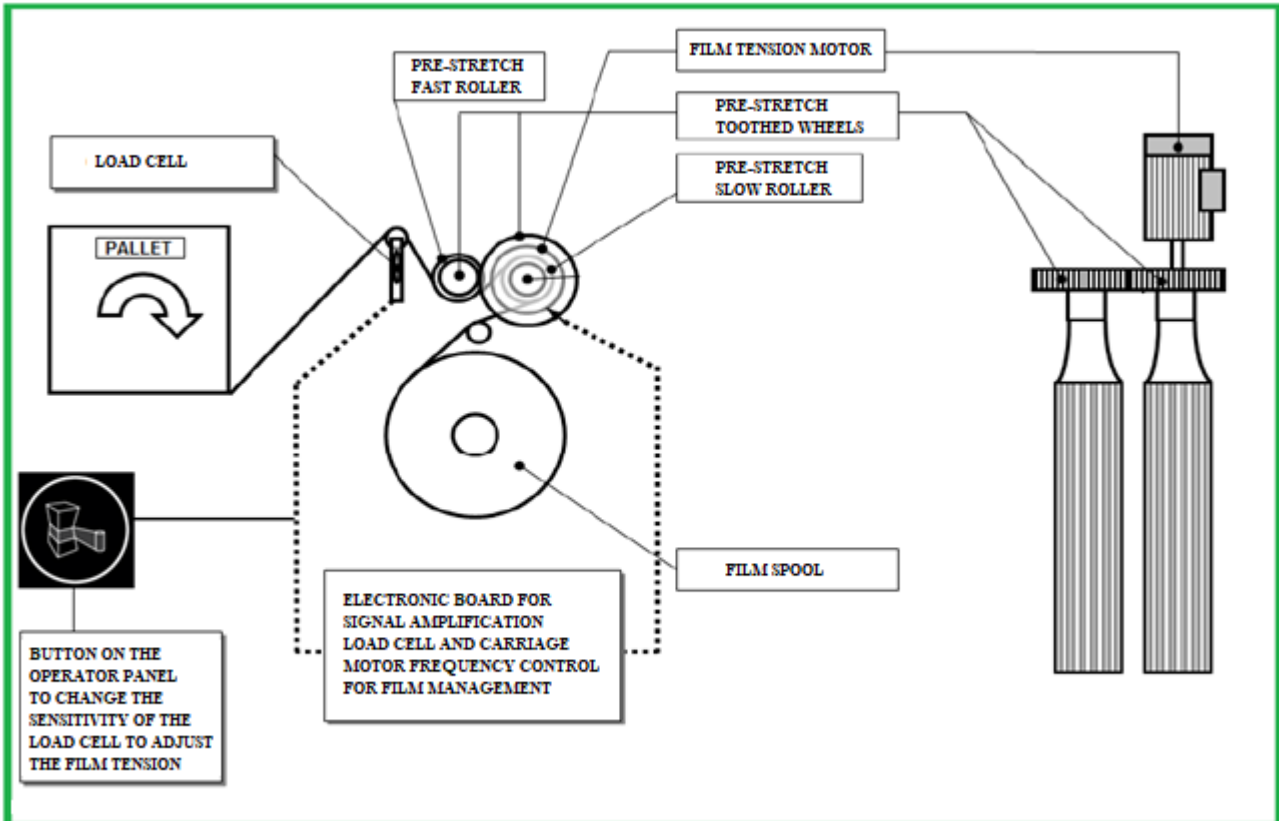

Selectable prestretch

230 %	YELLOW
0 %	GREEN
300 %	RED

60.2.109 rev. 01 – S7 standard -

PVS CARRIAGE

FILM Tensioning with LOAD CELL and VARIABLE PRESTRETCH

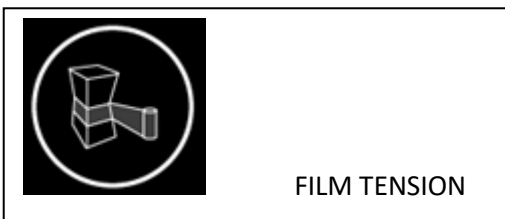
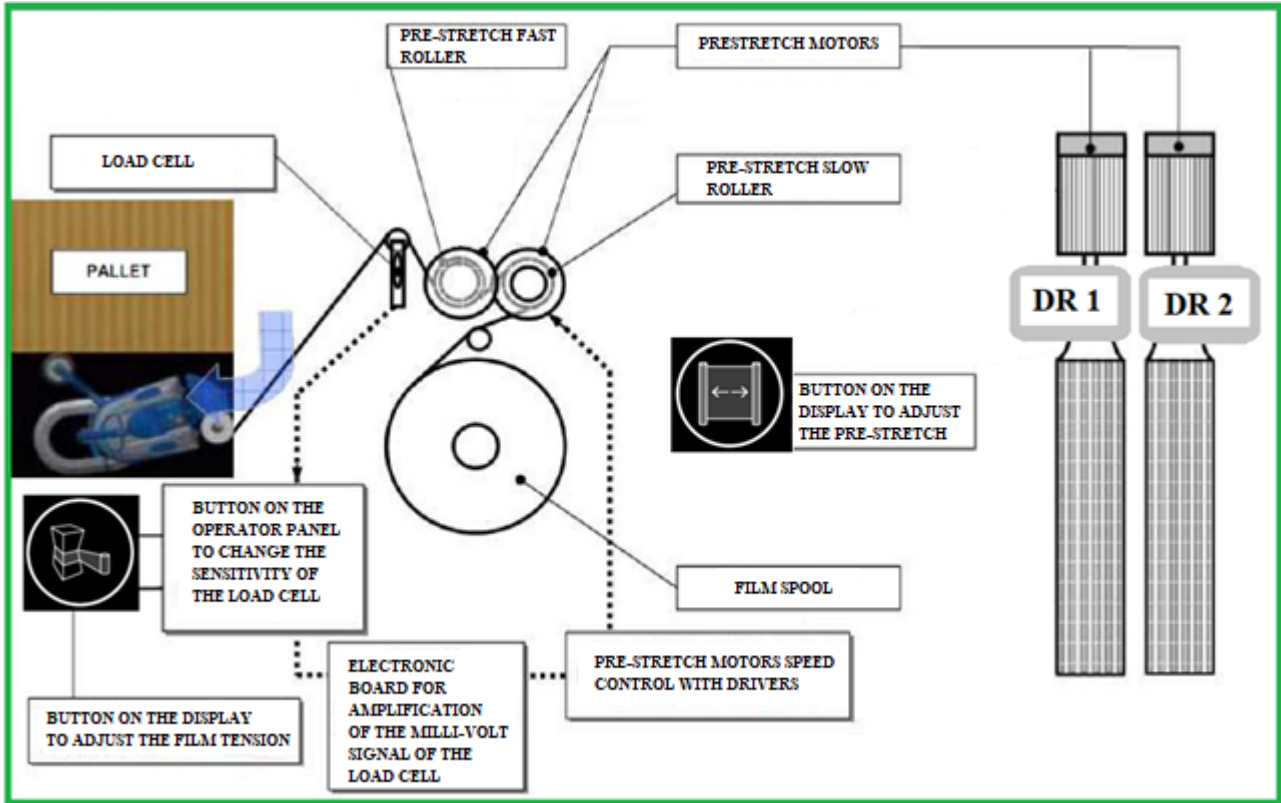

60.2.109 rev. 01 – S7 standard -

FILM PATH in P3GS and PVS carriages

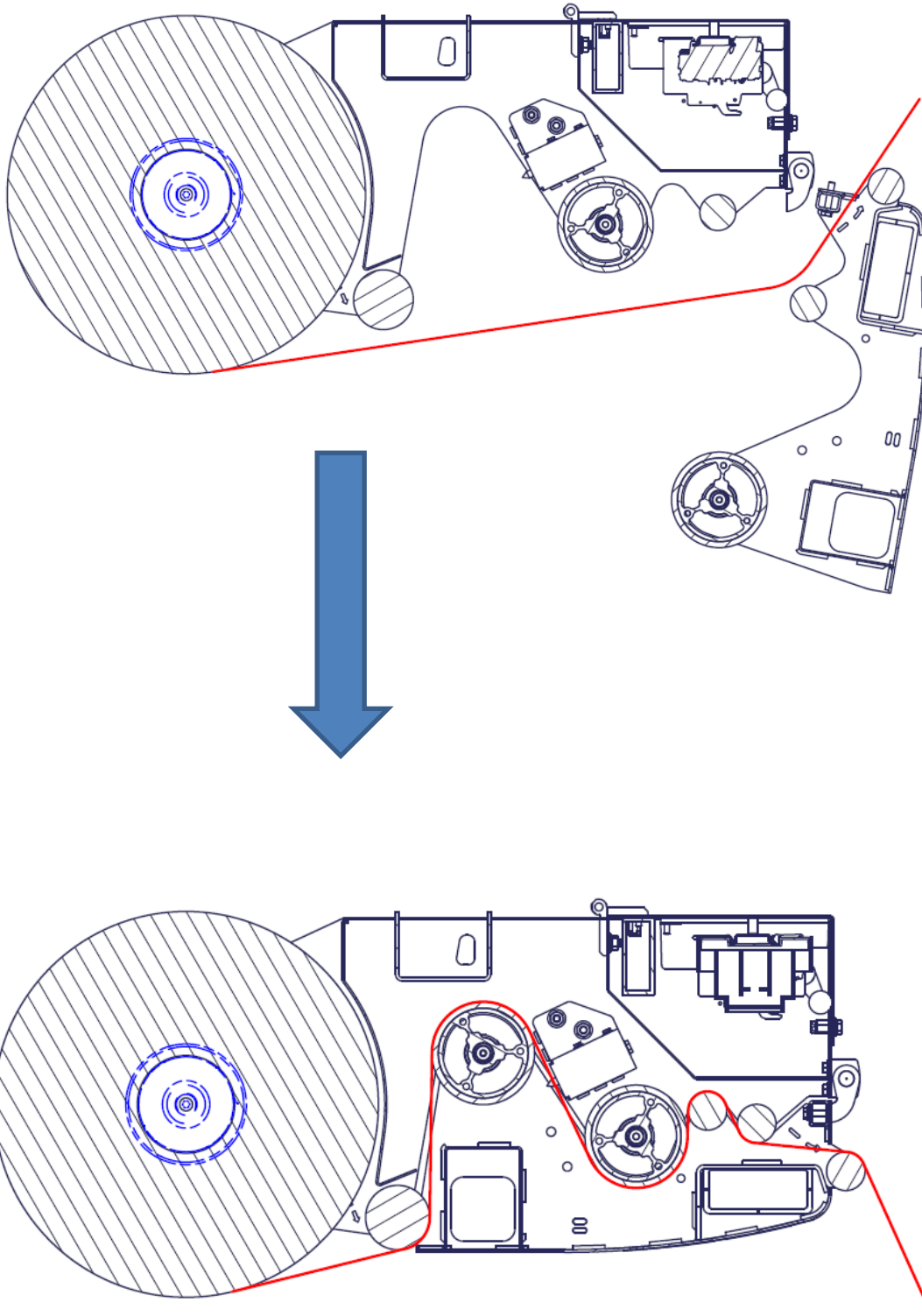

60.2.109 rev. 01 – S7 standard -

OPERATOR PANEL DESCRIPTION

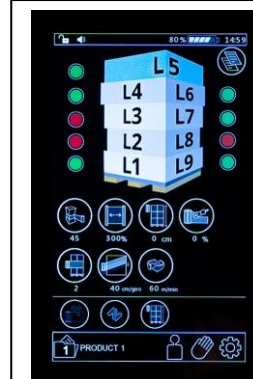
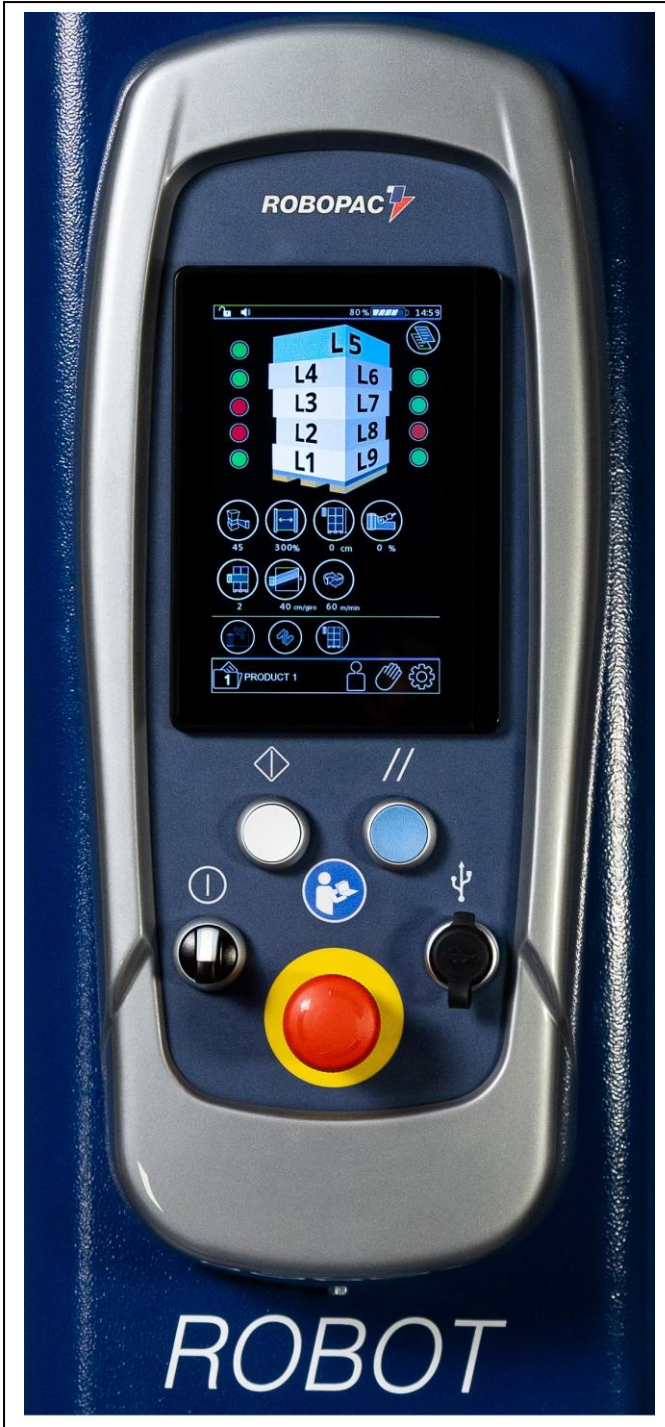

TOUCH SCREEN Panel



Machine ON / OFF



START Button



RESET Button



USB Port



EMERGENCY Button

60.2.109 rev. 01 – S7 standard -

BATTERY STATE DESCRIPTION

The battery level is displayed

- On the Panel with percentage value
100 % BATTERY TOTALLY FULL

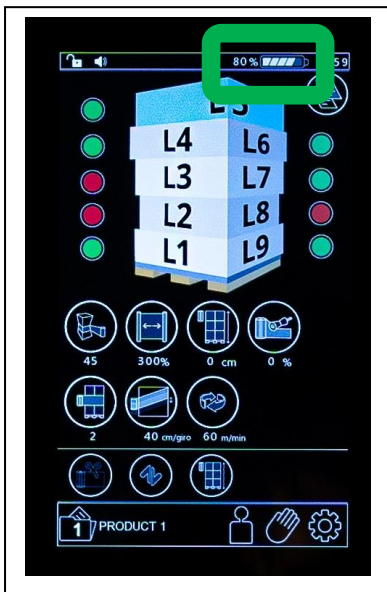



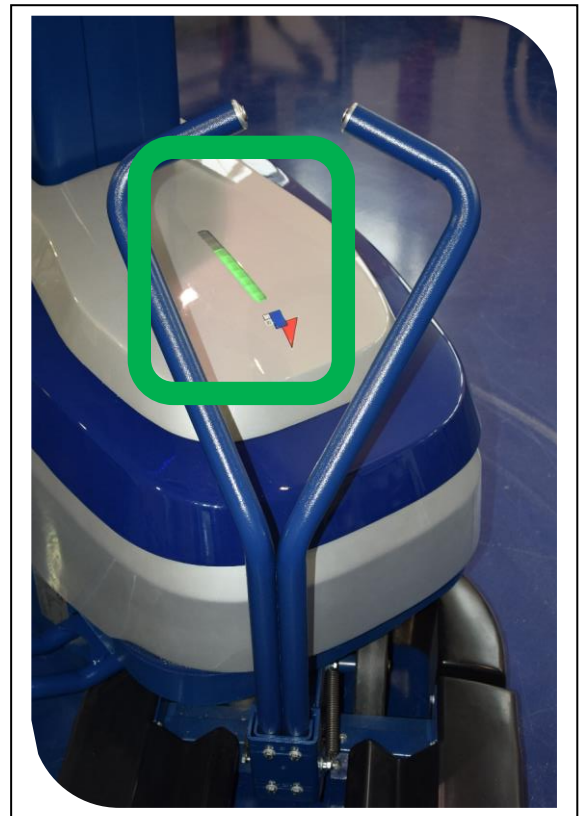

- On the robot carter with green leds ON
All the leds on BATTERY TOTALLY FULL





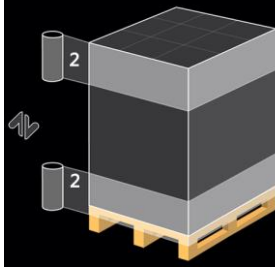

60.2.109 rev. 01 – S7 standard -

CYCLE PARAMETERS DESCRIPTION

Parameter		Values (min-max)	Step	Unit of measure
Type of packaging cycle		UP and DOWN Cycle		
		ONLY UP or ONLY DOWN Cycle		
		UP and DOWN Cycle with TOP		
Top Turns		0-10	1	Dimensionless
Bottom Turns		0-10	1	Dimensionless
Rotation Speed		35 - 80	1	Meters / minute

60.2.109 rev. 01 – S7 standard -

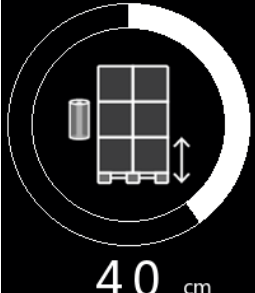

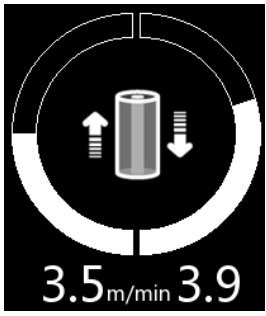

Parameter	Values (min-max)	Step	Unit of measure
Carriage Up Speed (meters / minute)	 1.5 – 5.5	0.1	Meters / minute
Carriage Down Speed (meters / minute)	 1.5 – 5.5	0.1	Meters / minute
Carriage Up Centimeters (centimeters of carriage ascent at each turn) similar of F1 CYCLE of Robot S6	 5 – 100	1	Centimeters
Carriage Down Centimeters (centimeters of carriage descent at each turn) similar of F1 CYCLE of Robot S6	 5 – 100	1	Centimeters
Offset from Ground	 40 cm	1	Centimeters

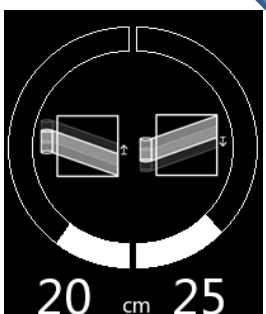

SAME
BUTTON
keep pressed



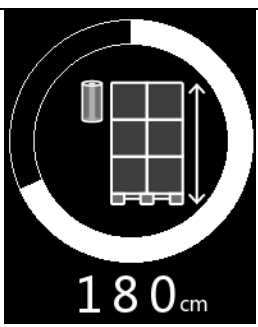
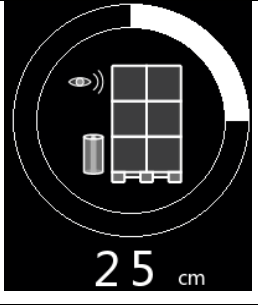

60.2.109 rev. 01 – S7 standard -

Parameter	Values (min-max)	Step	Unit of measure	
Reinforcement Tours		0 - 10	1	Dimensionless
Reinforcement Height		0 - 200	1	Centimeters
Altimeter		50 – 240	1	Centimeters
Photocell Delay		0 – 100	1	Centimeters
Film Cut		ON – OFF		

SAME
BUTTON
keep pressed

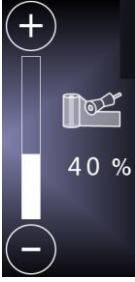
60.2.109 rev. 01 – S7 standard -

Parameter	Values (min-max)	Step	Unit of measure
Roping Turns (from Top to Bottom)	 0 - 10	1	Dimensionless
Roping percentage (from Top to Bottom)	 0% - 100 %	10 %	Percentage
Roping Turns (from Bottom to Top)	 0 - 10	1	Dimensionless
Roping percentage (from Bottom to Top)	 0% - 100 %	10 %	Percentage
Ergonomic ascent	0-100	1	Centimeters



**SAME BUTTON
keep pressed**



30 cm

60.2.109 rev. 01 – S7 standard -

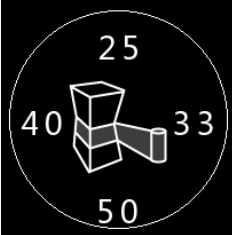
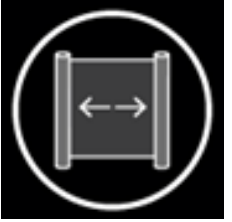
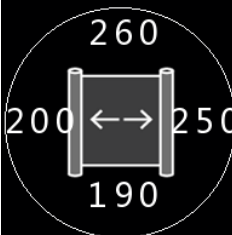
Parameter		Values (min-max)	Step	Unit of measure
Film Tension - FR - P3GS - PVS	 BUTTON PRESSED for 4 seconds  4 values . bottom turns film tension . ascent film tension . top turns film tension . descent film tension	0-100	1	Dimensionless
Prestretch - PVS	 BUTTON PRESSED for 4 seconds  4 valori . bottom turns prestretch . ascent prestretch . top turns prestretch . descent prestretch	0-P20 (parameter value P20 = 0-500)	10 %	Percentage

60.2.109 rev. 01 – S7 standard -

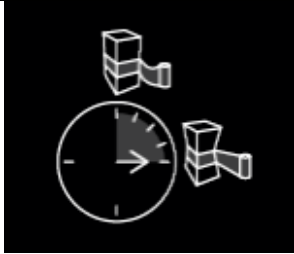
Parameter	Values (min-max)	Step	Unit of measure	
Film Tension Delay (at the start)		0-10	1	seconds

60.2.109 rev. 01 – S7 standard -

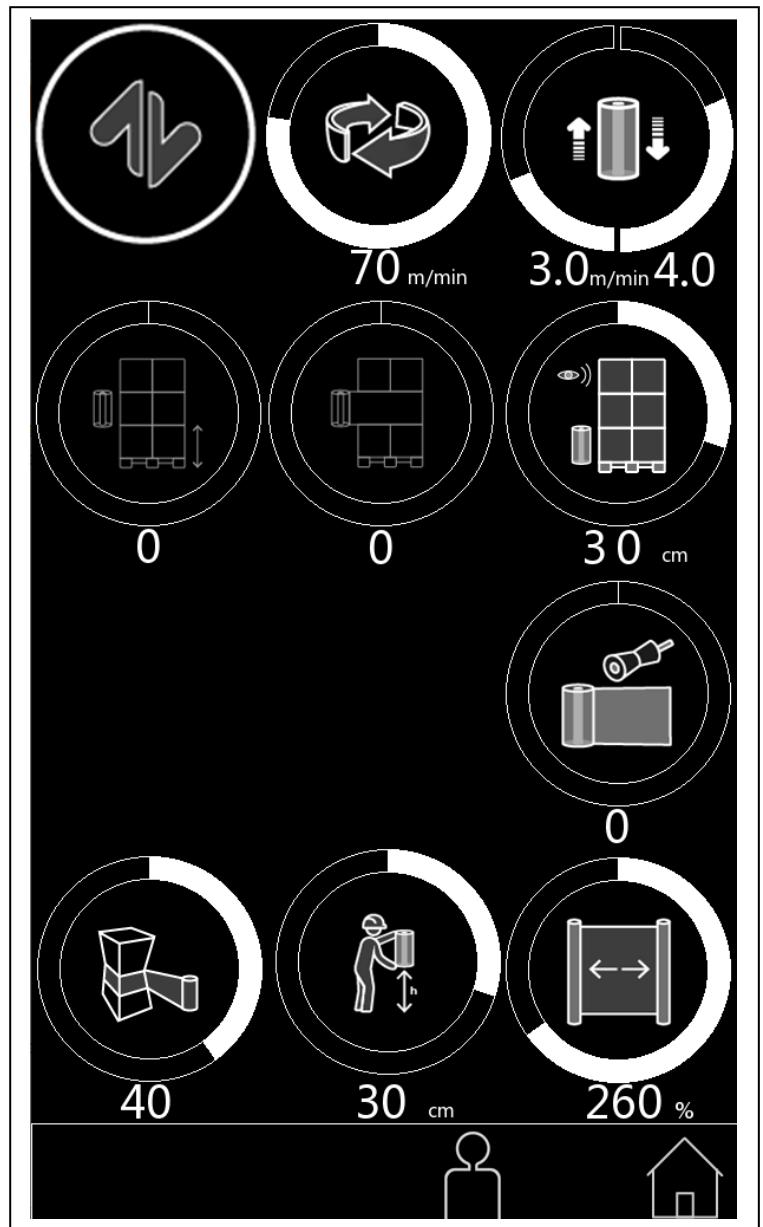
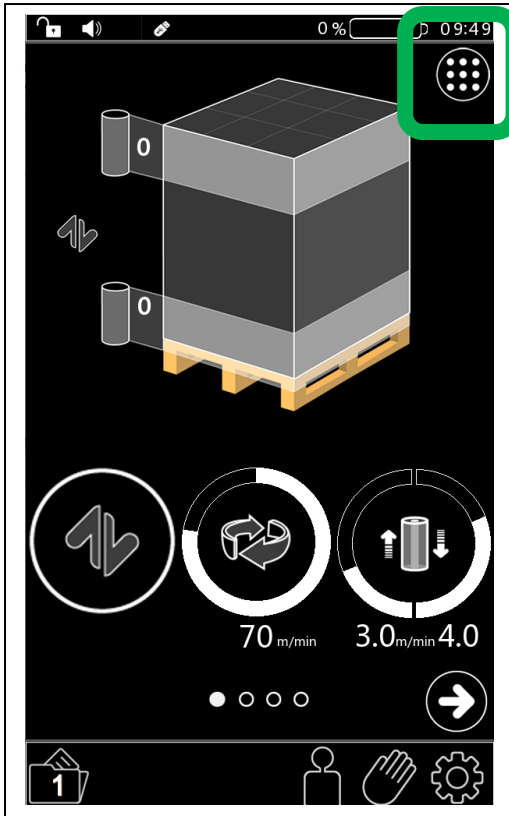

QUICK MENU

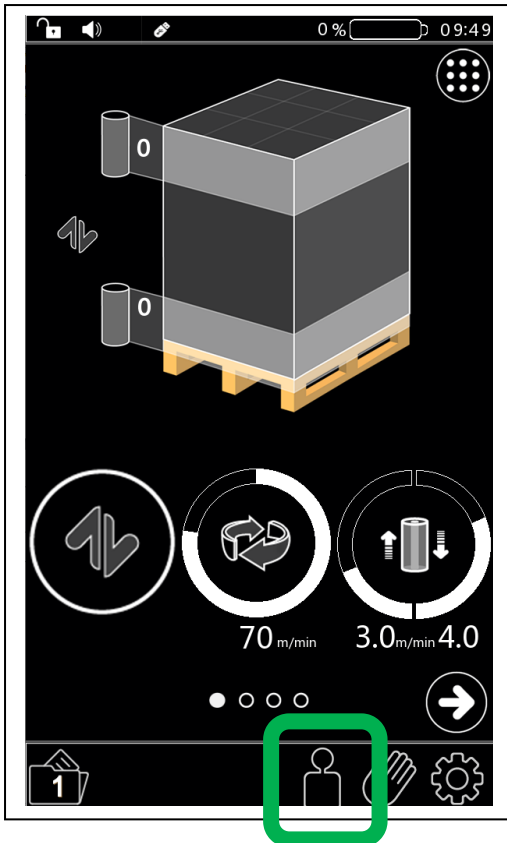

60.2.109 rev. 01 – S7 standard -

PASSWORDS MANAGEMENT



	<p>Customer Manager Password</p> <p>PSW = 1111</p> <p>Exchangeable (enter with 1111 password)</p>
	<p>SERVICE Password</p> <p>PSW = 6161</p> <p>NOT Exchangeable</p>

 Norm. Tecn. 60.2.113 rev. 00	TECHNICAL DOCUMENTATION ROBOT S7– Stop&Go	September 2022	Rev.04
	ENGLISH	Pag. 26 / 124	

60.2.109 rev. 01 – S7 standard -

Password for VISION SERVICE area



If the user presses the SERVICE page icon



and then press the icon to enter the service area **WITHOUT PASSWORD**

a pop-up will appear as below

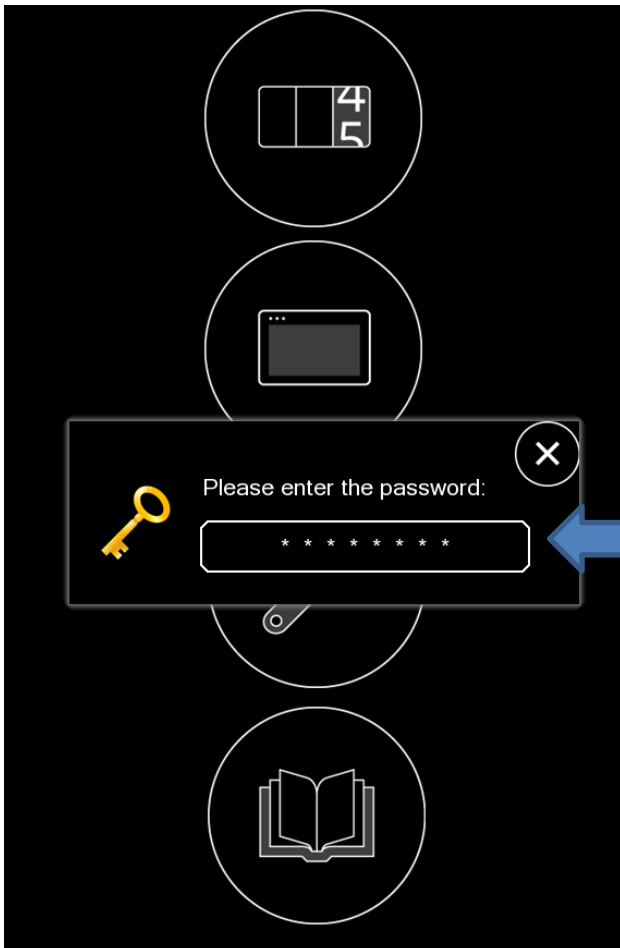

Insert the
PASSWORD = 2021
 To enter as **DISPLAY ONLY MODE**
 in the service area

60.2.109 rev. 01 – S7 standard -

RESET of the Customer Manager password to 1111

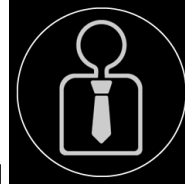

It is possible at any time to reset the Customer Manager password to 1111

- When switching on, wait for the RESET PRESSURE page
- Press the corners in SEQUENCE [1] then [2] then [3] then [4]



- The pop-up **PASSWORD RESET to 1111** is displayed

MANUAL OPERATIONS ON THE CARRIAGE



To move the carriage in manual, press

With SERVICE password ALL manual operations are possible

With CUSTOMER MANAGER password ONLY some manual operations are possible
Carriage, Roping, Cut-- > No Film Tension Motor (M3) and Prestretch Motor (M4)

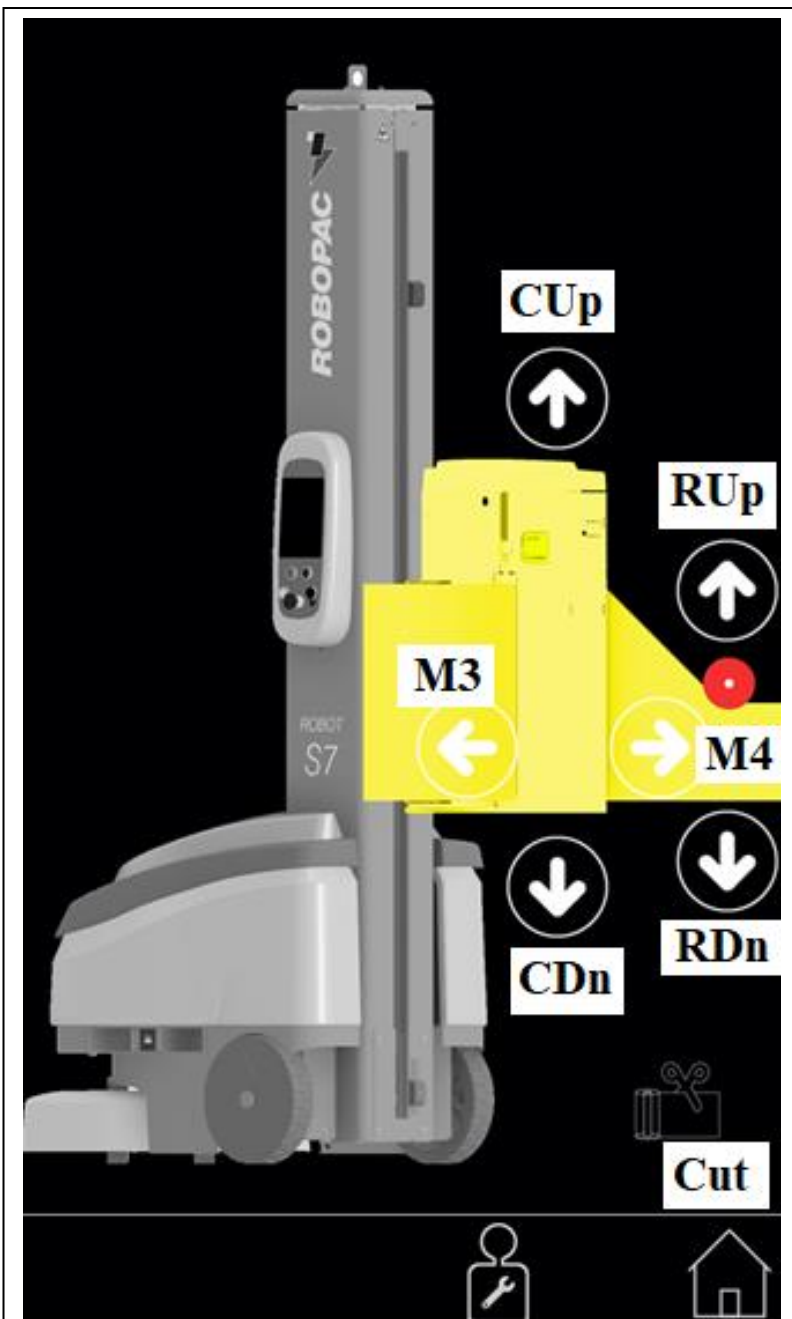

CUp = CARRIAGE UP

CDn = CARRIAGE DOWN

RUp = ROPING UP

RDn = ROPING DOWN

Cut = FILM CUT

M3 = Film Tension Motor

M4 = Prestretch Motor

MANUAL OPERATION ON THE STEERING BAR - the steering bar must be DOWN -

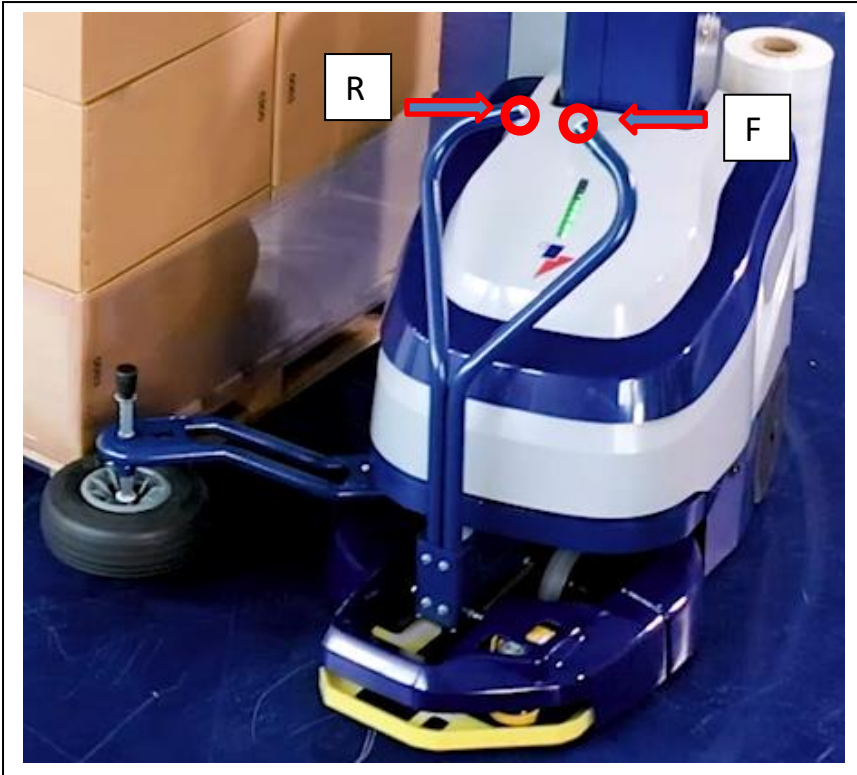

Button F:

Robot forward in Manual

R button:

Robot back in Manual

Forward / backward movement stops if

- The button is released
- You also press the other button
- The steering bar is reset UP

The scanner intervention area is very limited to 20 centimeters from the ROBOT - **ORANGE area** -

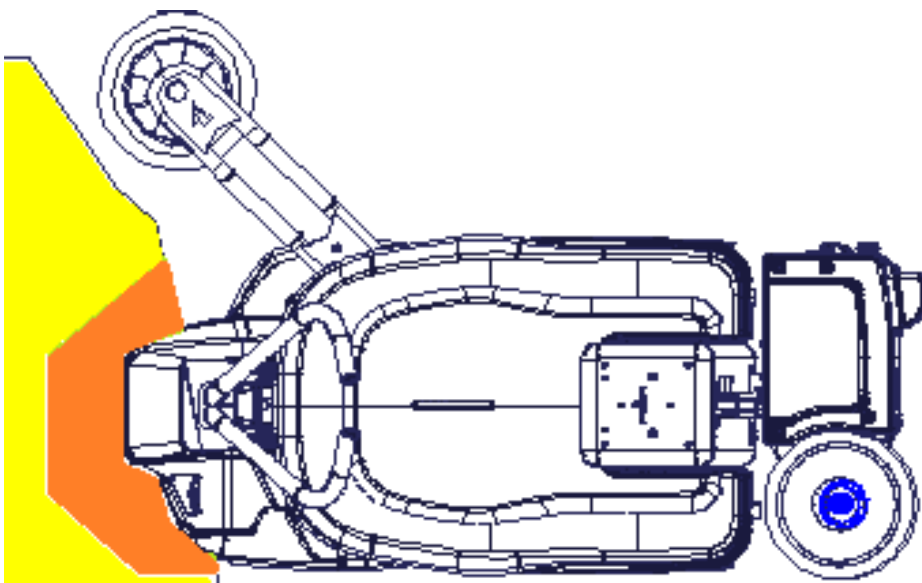

LED SIGNALING OF THE STEERING BAR BUTTONS

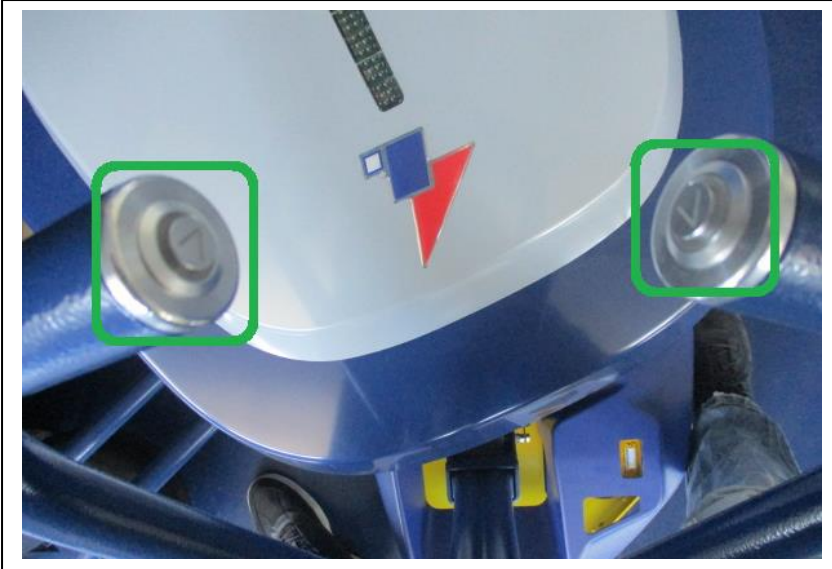

LED OFF

with steering bar UP --- > Manual function NOT ACTIVE



LED ON WHITE color

with steering bar DOWN --- > Manual function ACTIVE

WHITE FLASHING LED

only in case of anomaly --->

contact of the relative button glued or always active

 Norm. Tecn. 60.2.113 rev. 00	TECHNICAL DOCUMENTATION ROBOT S7– Stop&Go	September 2022	Rev.04
	ENGLISH	Pag. 31 / 124	

60.2.109 rev. 01 – S7 standard -

FAST FORWARD in Manual

Function not present

 Norm. Tecn. 60.2.113 rev. 00	TECHNICAL DOCUMENTATION ROBOT S7– Stop&Go	September 2022	Rev.04
	ENGLISH	Pag. 32 / 124	

60.2.109 rev. 01 – S7 standard -

CIRCULAR LED MEANING

The circular LED has different colors depending on the state of the machine



RED	Alarm
WHITE	Manual operations
GREEN	Waiting for START
BLUE	Waiting for RESET
YELLOW	Machine working

60.2.109 rev. 01 – S7 standard -

CYCLE SELECTION

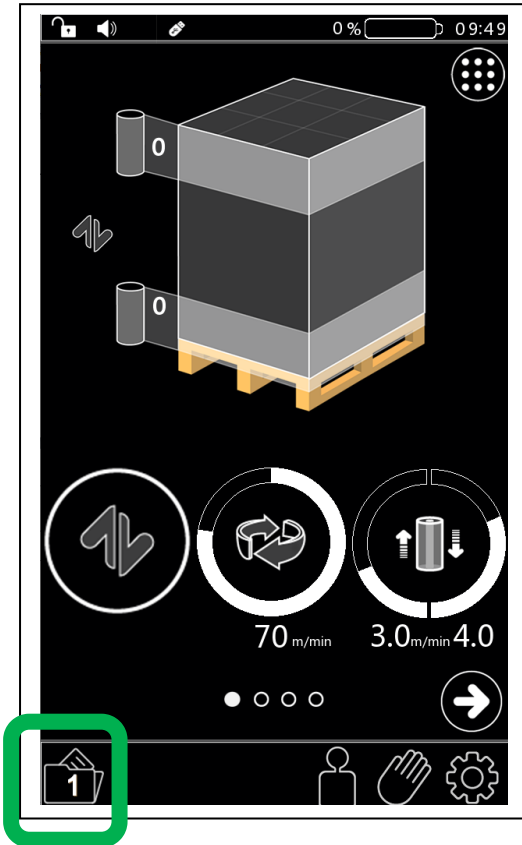

STANDARD Cycle

MULTILAYER Cycle

60.2.109 rev. 01 – S7 standard -

SERVICE PAGES

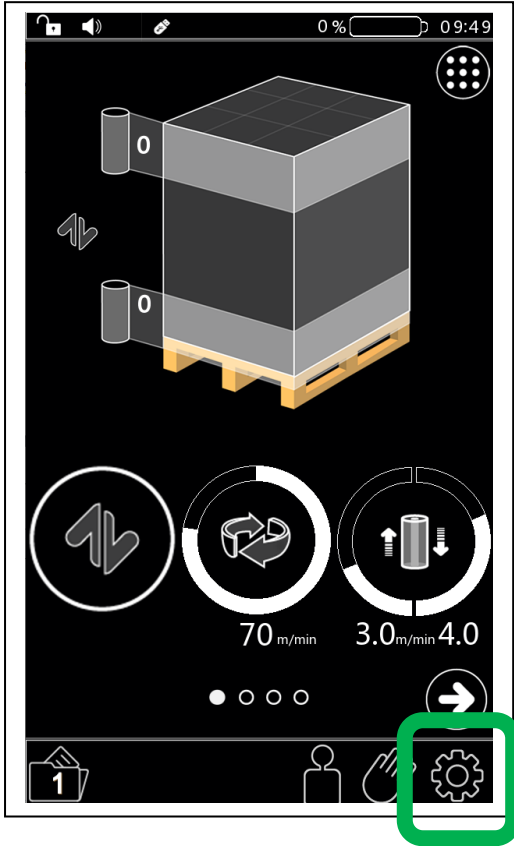

	<p>Counters</p>		<p>Service Pages</p>
	<p>Various settings and information</p>		<p>Documents and video</p>

COUNTERS

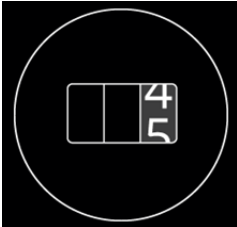

Partial number of cycles

Resettable with

Password 1111 or 6161

60.2.109 rev. 01 – S7 standard -

VARIOUS SETTINGS AND INFORMATION

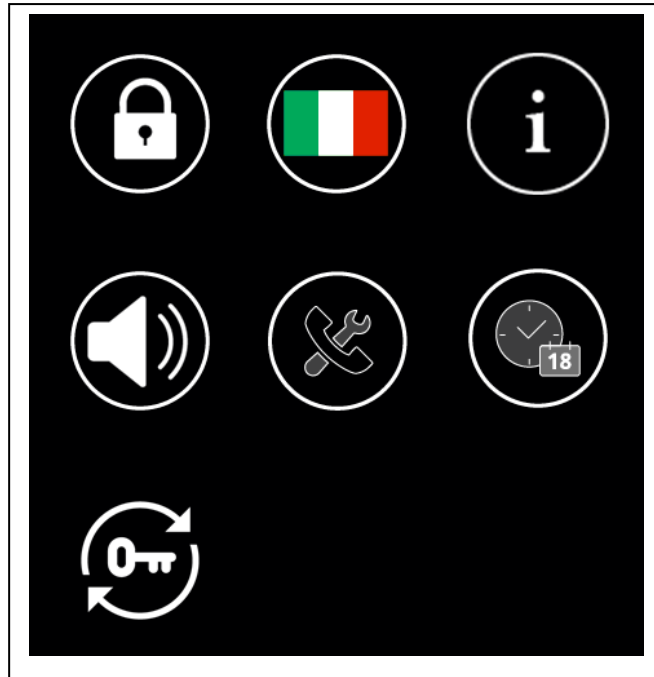
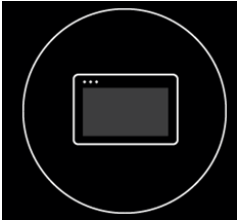

Language Selection



Boards and Software Information



Acoustic Signal



Assistance Phone

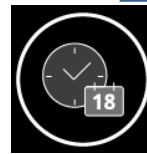

Date and Hour

WITHOUT
PASSWORD



Parameters Lock / Unlock

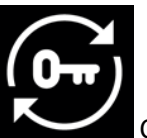

Change of the Customer Manager Password

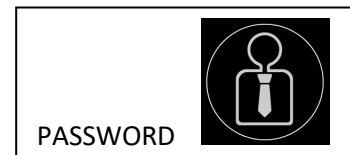

60.2.109 rev. 01 – S7 standard -

SERVICE PAGES

access **ONLY** with **PASSWORDS**

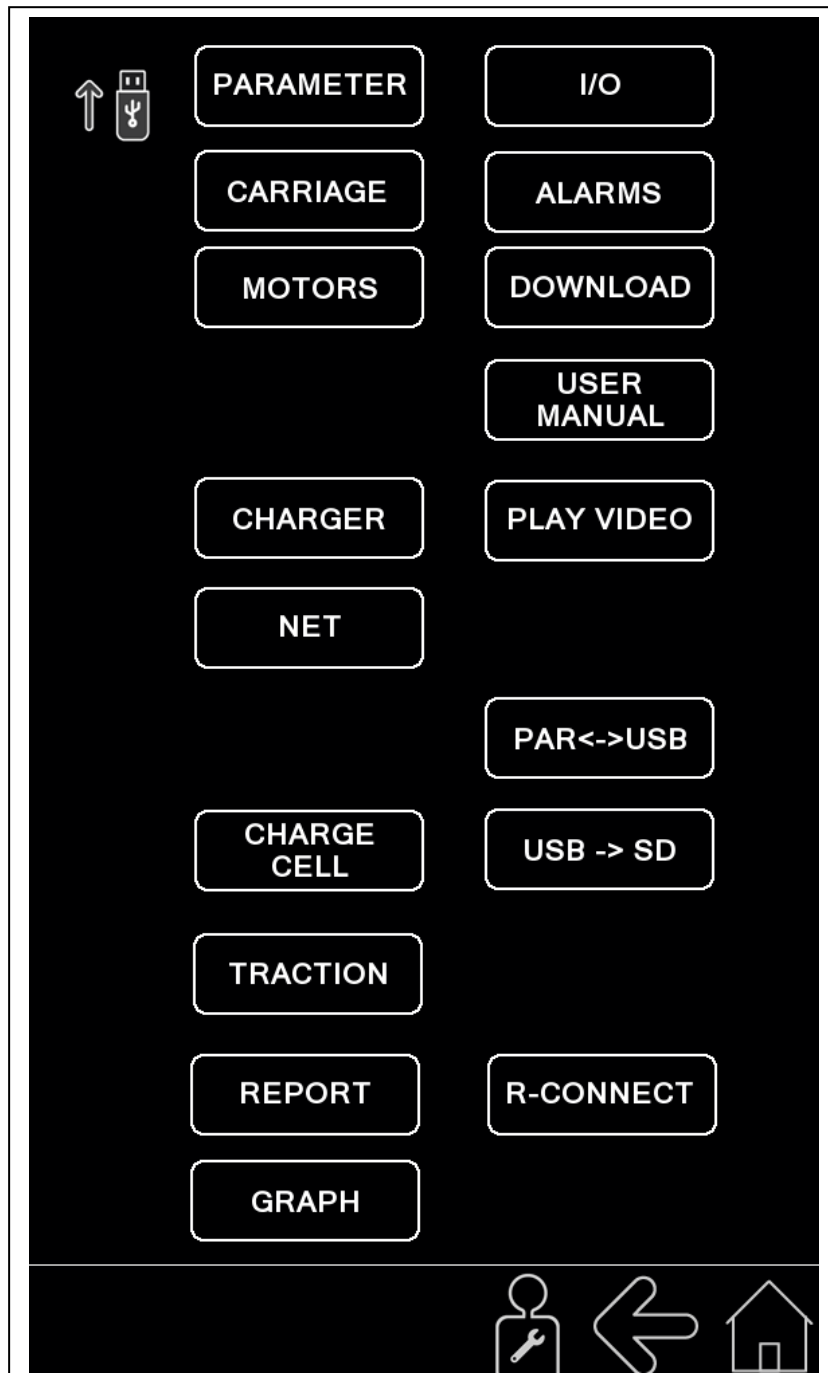

 Norm. Tecn. 60.2.113 rev. 00	TECHNICAL DOCUMENTATION ROBOT S7– Stop&Go	September 2022	Rev.04
	ENGLISH	Pag. 38 / 124	

60.2.109 rev. 01 – S7 standard -

CONFIGURATION PARAMETERS

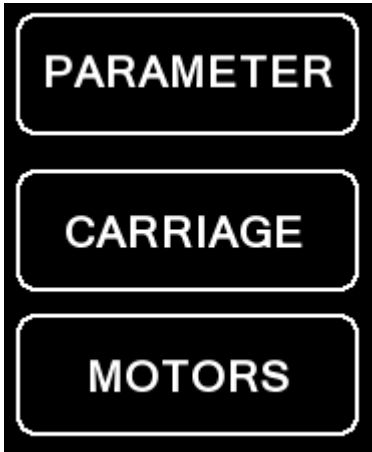

Vision with Customer Manager Password



Modification with Service Password

 Norm. Tecn. 60.2.113 rev. 00	TECHNICAL DOCUMENTATION ROBOT S7– Stop&Go	September 2022	Rev.04
	ENGLISH	Pag. 39 / 124	

60.2.109 rev. 01 – S7 standard -

ACCESS to CONFIGURATION PARAMETERS



For the modification the password 6161 is required





Press on

 Norm. Tecn. 60.2.113 rev. 00	TECHNICAL DOCUMENTATION ROBOT S7– Stop&Go	September 2022	Rev.04
	ENGLISH	Pag. 40 / 124	

60.2.109 rev. 01 – S7 standard -

CONFIGURATION PARAMETERS DEFAULT

Press  and confirm the pop up window displayed 

press the ARROW BELOW

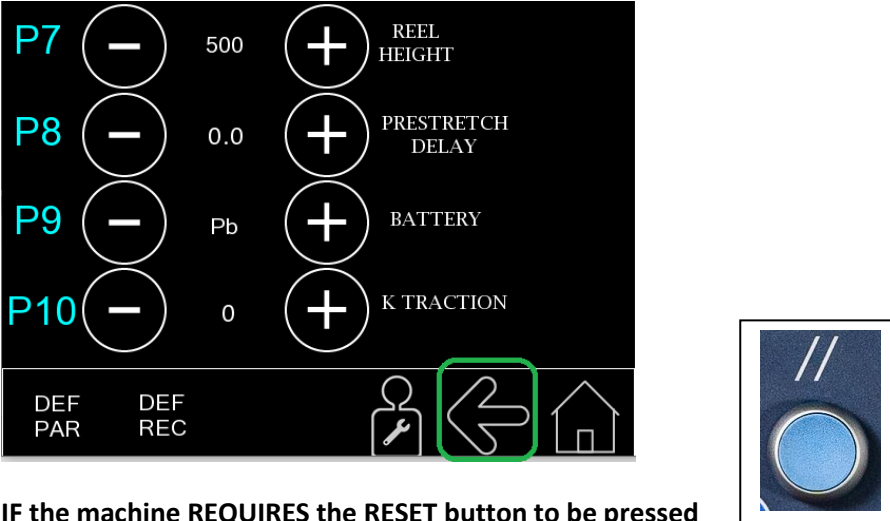

IF the machine REQUIRES the RESET button to be pressed

--- > the parameters are stored automatically (**from** June 2022)

IF the machine DOES NOT REQUIRE the RESET button to be pressed

--- > to memorize the parameters it is **NECESSARY TO TURN OFF/ON** the machine (**until** June 2022)

 Norm. Tecn. 60.2.113 rev. 00	TECHNICAL DOCUMENTATION ROBOT S7– Stop&Go	September 2022	Rev.04
	ENGLISH	Pag. 41 / 124	

60.2.109 rev. 01 – S7 standard -

LIST of the CONFIGURATION PARAMETERS

Below is the list of configuration parameters,
 after any modification (password 6161 required)



press the ARROW BELOW

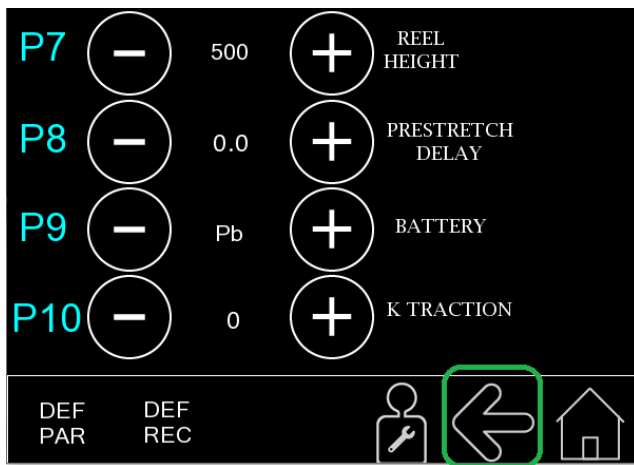

IF the machine REQUIRES the RESET button to be pressed

--- > the parameters are stored automatically (**from** June 2022)

IF the machine DOES NOT REQUIRE the RESET button to be pressed

--- > to memorize the parameters it is **NECESSARY TO TURN OFF/ON** the machine (**until** June 2022)

Parameter	Values	Default	Parameter Description
P1	EU – US	EU	U.S.A. DISPLAY Enable
P2	21.0 – 25.0	23.7	V Min BATTERY Voltage
P3	ON - OFF	OFF	Beeper Enable during the Cycle
P4	0 - 90	30	Auto power OFF Time – minuts
P5	0 - 50	25	Top Descent – centimeters
P6	ON - OFF	ON	Free
P7	500 - 750	500	Spool Height
P8	0.0 – 10.0	0	Free
P9	Pb - Li	Pb	Battery Type
P10	-1000 +1000	-500	K Traction Correction on lap calculation (360 °), do not modify
P11	ON- OFF	OFF	Traction Alarm
P12	OFF – ON – ON FAST	0	Film cutting enable (ON FAST does NOT provide for the slowdown during the cutting preparation phase, the slowdown has been introduced to improve and make the cut repeatable regardless of the machine starting point)
P13	0 – 200	80	Tail Lenght film cut
P14 – P17	0	0	Free
P18	0 – 200	55	Film density g / 5m
P19	2200 – 2400 - 2800 - 3000	2200	Mast Height
P20	200 - 500	500	Max Prestretch (only for PVS)
P21	1	1	Enabling Control Unit for Laser Scanner (Robopac only)
P22	0	0	Restart (Robopac only)
P23	OFF	OFF	Simulation (Robopac only)
P24	0 - 360	320	Advance Stop Angle at which the robot goes in low speed during the last turn for zero position
P25	OFF	OFF	Comm + (Robopac only)
P26	0 – 20	0	Charger (battery charger analysis warning not implemented)
P27	OFF	OFF	(Robopac only)
P28 – P30	0	0	Free

 Norm. Tecn. 60.2.113 rev. 00	TECHNICAL DOCUMENTATION ROBOT S7– Stop&Go	September 2022	Rev.04
	ENGLISH	Pag. 43 / 124	

60.2.109 rev. 01 – S7 standard -

ACCESS to CARRIAGE PARAMETERS



For the modification the password 6161 is required



Press on

DEFAULT of the CARRIAGE PARAMETERS



Press

and confirm the pop up window displayed

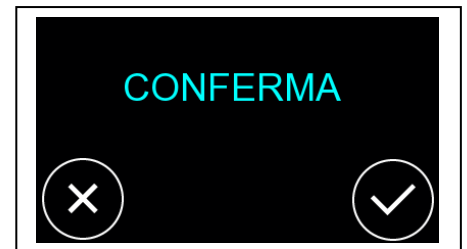

Press

to write the panel parameters to the memory

The “W” button becomes **RED** to indicate the writing then becomes **GREEN** as confirmation of the end of writing

 Norm. Tec. 60.2.113 rev. 00	TECHNICAL DOCUMENTATION ROBOT S7– Stop&Go	September 2022	Rev.04
	ENGLISH	Pag. 44 / 124	

60.2.109 rev. 01 – S7 standard -

LIST of the CARRIAGE PARAMETERS



Below is the list of carriage parameters, after any modification (password 6161 required)



Press **W** to write the panel parameters to the memory

The “W” button becomes **RED** to indicate the writing then becomes **GREEN** as confirmation of the end of writing

Parameter	Values	Default	Parameter Description
C1	FRD – FR P3GS - PVS	FRD	Type of the Carriage
C2	ON - OFF	OFF	Roping
C3	0 - 100	30	KP Film treatment, proportional constant
C4	0 - 100	59	KI Film treatment, integrative constant
C5	0 – 100	3	KD Film treatment, derivative constant
C6	0 - 100	20 50	TMIN Minimum deviation of the cell under which the film treatment does not work from june 2022
C7	0 - 100	80	DELTA Distance (* 10) between cell value for film tension = 0 and film tension = 100
C8	OFF ROLLER CELL BOTH	OFF	Film Break Alarm ROLLER = R-connect film consumption roller CELL = load cell BOTH = both (roller and cell) FRD / FR --- > C8 = OFF FRD / FR with film break/consumption --- > C8 = ROLLER P3GS / PVS --- > C8 = CELL P3GS / PVS with film consumption --- > C8 = BOTH
C9	0 - 100	70	PWM Clutch % PWM of the clutch for maximum film tension in FR
C10	0 - 100	30	KPrest prestretch constant
C11	0 - 100	60	Roping Advance Encoder pulses before the target to be traversed at low speed
C12	0 - 100	30	Roping Max Stretch Maximum film tension during roping
C13	0 - 100	10	Roping Min Stretch Minimal film tension during roping
C14	0.0 – 10.0 (dSec)	0	Time Manual Film Indicates how long the rollers continue to rotate after releasing the manual film button
C15	0.015 – 1.000 (Sec)	0.015	Photocell Delay Photocell filter to filter any small erroneous readings
C16 – C20	0	0	Free

 Norm. Tecn. 60.2.113 rev. 00	TECHNICAL DOCUMENTATION ROBOT S7– Stop&Go	September 2022	Rev.04
	ENGLISH	Pag. 45 / 124	

60.2.109 rev. 01 – S7 standard -

ACCESS to MOTOR PARAMETERS



For the modification the password 6161 is required



Press on

MOTOR PARAMETERS DEFAULT



Press

and confirm the pop up window displayed

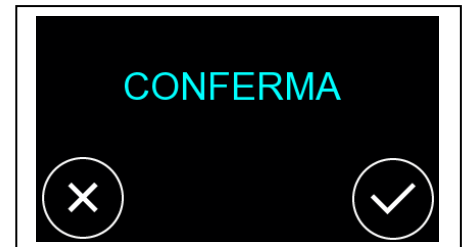

Press

to write the panel parameters to the memory

The "W" button becomes **RED** to indicate the writing then becomes **GREEN** as confirmation of the end of writing

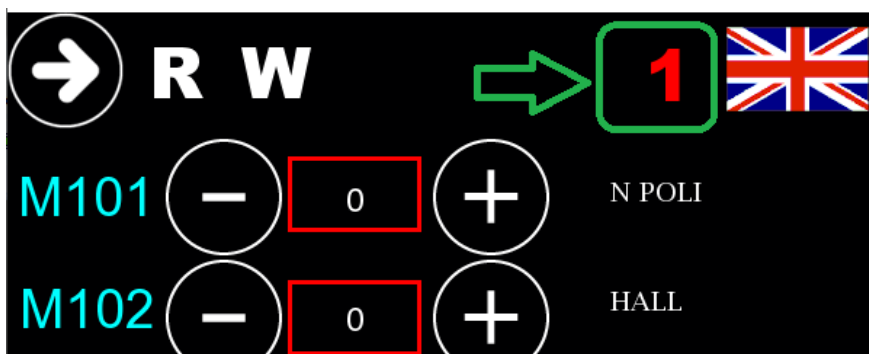

Press on 1 to
change the number
of the motor displayed

 Norm. Tecn. 60.2.113 rev. 00	TECHNICAL DOCUMENTATION ROBOT S7– Stop&Go	September 2022	Rev.04
	ENGLISH	Pag. 46 / 124	

60.2.109 rev. 01 – S7 standard -

LIST of the MOTOR PARAMETERS



Below is the list of motor parameters, after any modification (password 6161 required)



Press  to write the panel parameters to the memory

The “W” button becomes **RED** to indicate the writing then becomes **GREEN** as confirmation of the end of writing

MXYY : **X = motor number**

1 rotation 2 carriage 3 tension 4 prestretch 5 roping

YY = parameter number (01-20)

Par.	Parameter Description	ROTATION Motor 1 Default	CARRIAGE Motor 2 Default	FILM TENSION Motor 3 Default	PRESTRETCH Motor 4 Default	ROPING Motor 5 Default
Mx01	N POLI	M101 = 4	M201 = 4	M301 = 4	M401 = 4	M501 = 4
Mx02	HALL	M102 = 32	M202 = 32	M302 = 32	M402 = 32	M502 = 32
Mx03	ACC	M103 = 2000	M203 = 500	M303 = 130	M403 = 30	M503 = 300
Mx04	DEC	M104 = 100	M204 = 100	M304 = 130	M404 = 30	M504 = 50
Mx05	QSTOP	M105 = 100	M205 = 100	M305 = 100	M405 = 100	M505 = 50
Mx06	INom	M106 = 20	M206 = 15	M306 = 20	M406 = 20	M506 = 10
Mx07	l2t	M107 = 15	M207 = 15	M307 = 10	M407 = 10	M507 = 10
Mx08	vKP	M108 = 15	M208 = 40	M308 = 40	M408 = 50	M508 = 5
Mx09	vKI	M109 = 6	M209 = 24	M309 = 10	M409 = 10	M509 = 2
Mx10	vFilter	M110 = 100	M210 = 200	M310 = 200	M410 = 200	M510 = 200
Mx11	tBrake	M111 = 10	M211 = 10	M311 = 10	M411 = 10	M511 = 10
Mx12	cKP	M112 = 250	M212 = 280	M312 = 500	M412 = 500	M512 = 800
Mx13	cKI	M113 = 100	M213 = 120	M313 = 100	M413 = 100	M513 = 600
Mx14	rStatore	M114 = 20	M214 = 25	M314 = 30	M414 = 30	M514 = 190
Mx15	hSincrona	M115 = 7	M215 = 10	M315 = 20	M415 = 20	M515 = 26
Mx16	flusso	M116 = 100	M216 = 94	M316 = 90	M416 = 90	M516 = 50
Mx17	iMax	M117 = 70	M217 = 50	M317 = 45	M417 = 45	M517 = 20
Mx18	Libero	M118 = 0	M218 = 0	M318 = 0	M418 = 0	M518 = 0
Mx19	Libero	M119 = 0	M219 = 0	M319 = 0	M419 = 0	M519 = 0
Mx20	Libero	M120 = 0	M220 = 0	M320 = 0	M420 = 0	M520 = 0

 Norm. Tecn. 60.2.113 rev. 00	TECHNICAL DOCUMENTATION ROBOT S7– Stop&Go	September 2022	Rev.04
	ENGLISH	Pag. 47 / 124	



60.2.109 rev. 01 – S7 standard -

LOAD CELL CALIBRATION

After to be sure that

- No Film is present on the rollers
- The roller connected to the load cell to be in correct mechanical conditions

Enter with the SERVICE password 6161  or Customer manager password 

Press  then press 

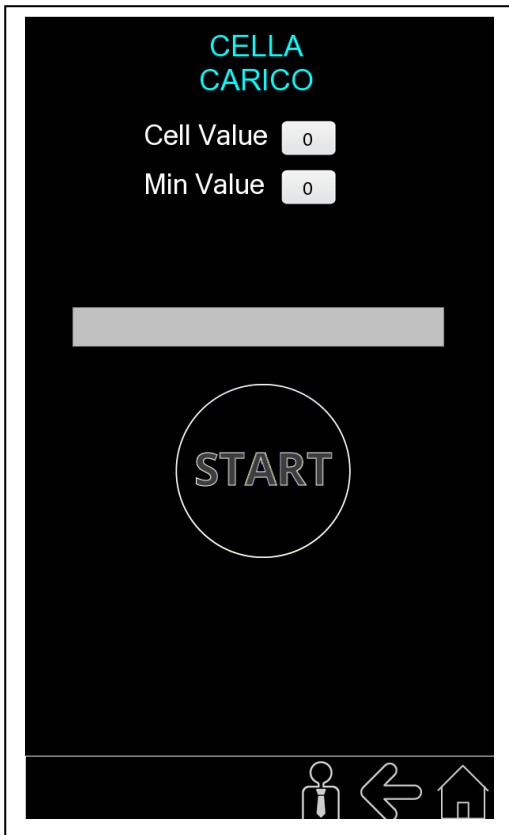

PRESS

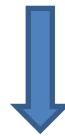
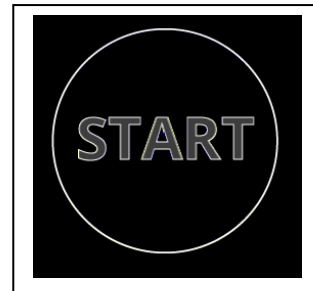

Calibration OK

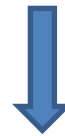

Calibration
NOT correct

 Norm. Tecn. 60.2.113 rev. 00	TECHNICAL DOCUMENTATION ROBOT S7– Stop&Go	September 2022	Rev.04
	ENGLISH	Pag. 48 / 124	

60.2.109 rev. 01 – S7 standard -

VARIABLE ROPING CALIBRATION/SETTING

In the case of variable roping problems, in case of installation of the roping group, in case of change of the carriage PLC and in case of Alarm E6404 make the ROPING DEVICE CALIBRATION



Enter with the SERVICE password 6161



Press

then press

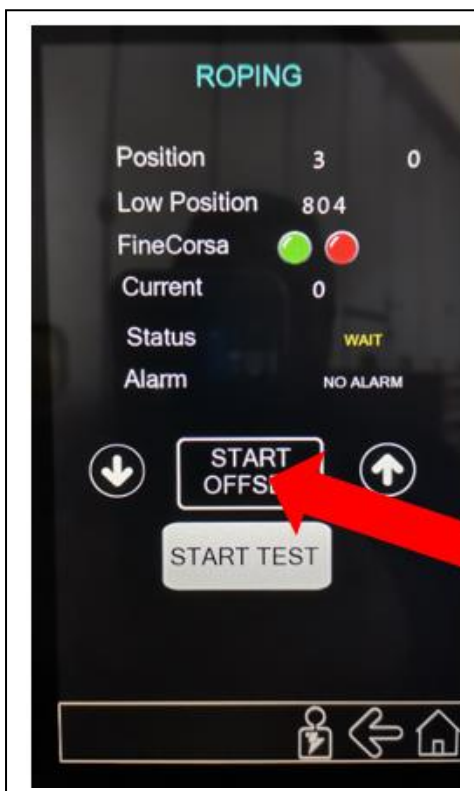

Press "START OFFSET" and wait the end of the AUTOMATIC TEST.

During the cycle the two icons of the limit switches turn on.

When the **Status** indication turns green, the procedure is completed correctly

60.2.109 rev. 01 – S7 standard -

CARRIAGE TEST CYCLE



Enter to the REPORT page pressing the buttons in sequence



Start the LIFTING cycle (**L**) --- > **WITHOUT FILM SPOOL** on the **CARRIAGE**

to allow to the software to register all the values related to the operation of the carriage.



At the end of the cycle the values at the left underlined in red are filled with the values detected during the cycle.

The values detected can be send with Rconnect with

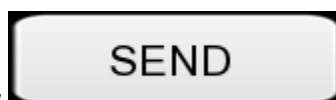

the button at the top right indicated by the arrow

The GLOBAL cycle has to be eventually performed **WITH FILM SPOOL MOUNTED** on the **CARRIAGE**

60.2.109 rev. 01 – S7 standard -

COMUNICATION CHECK between DEVICES

Enter to the NET page with the sequence of the buttons

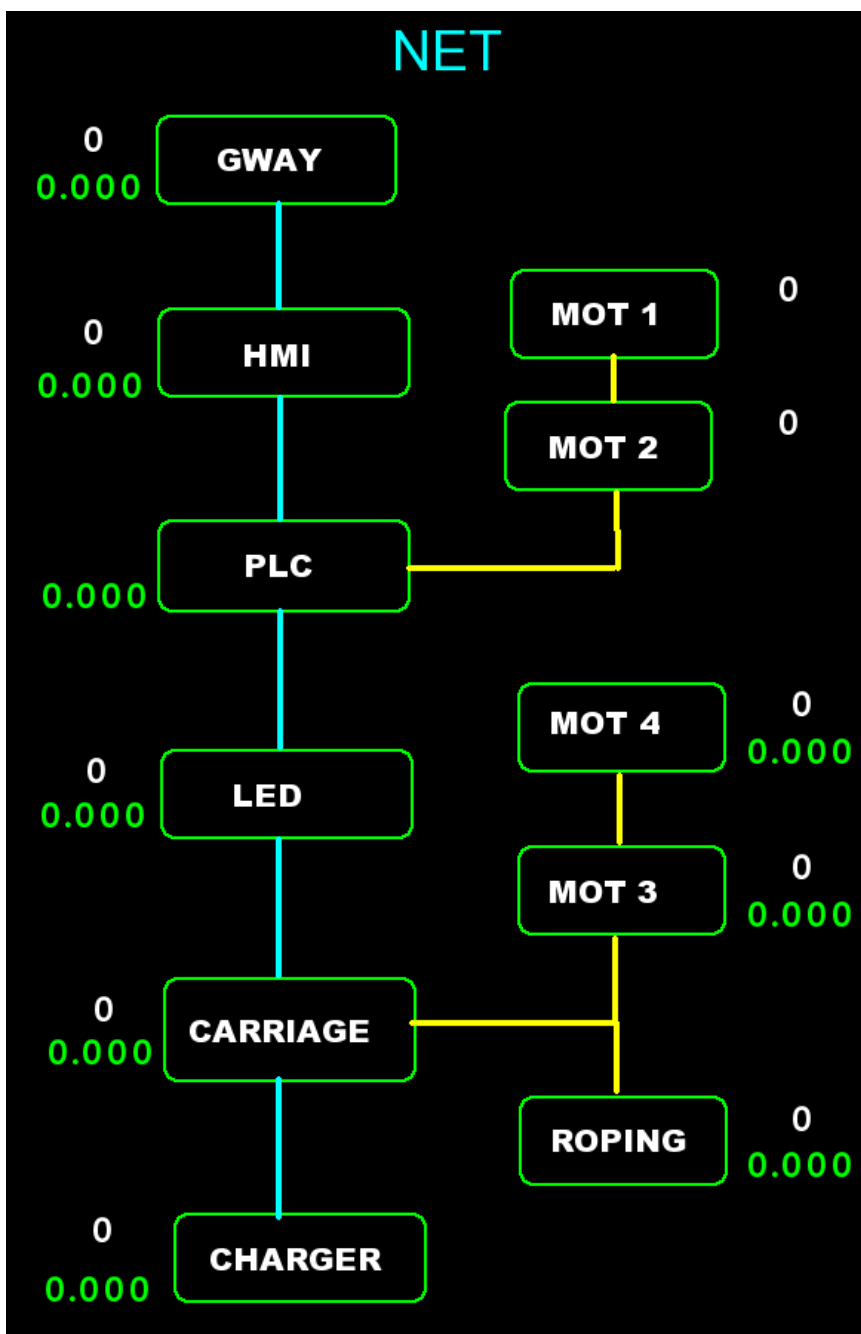

CAN Communication

--- YELLOW CONNECTIONS ---

MODBUS Communication

--- BLUES CONNECTIONS ---

- **GTWAY** = R-Connect
- **HMI** = Touch Screen
- **PLC** =
PLC on the electrical box
- **LED** = LED Module
- **CARRIAGE** =
PLC on the CARRIAGE
- **CHARGER** =
Battery Charger
- **MOT1** = Driver for Traction Motor
- **MOT2** = Driver for Carriage Motor (up/down)
- **MOT3** = Driver for Film Tension Motor
- **MOT4** = Driver for Prestretch Motor
- **ROPING** = Driver for Roping Motor

 Norm. Tecn. 60.2.113 rev. 00	TECHNICAL DOCUMENTATION ROBOT S7– Stop&Go	September 2022	Rev.04
	ENGLISH	Pag. 52 / 124	

60.2.109 rev. 01 – S7 standard -

PRODUCT HEIGHT DETECTION PHOTOCELL CALIBRATION

STANDARD PHOTOCELL (for clear products)

Adjust the photocell sensitivity trimmer about to load center;

approximately set the trimmer to time 2

(looking the photocell from back in order to read the written DL).

PHOTOCELL FOR BLACK PRODUCTS S62

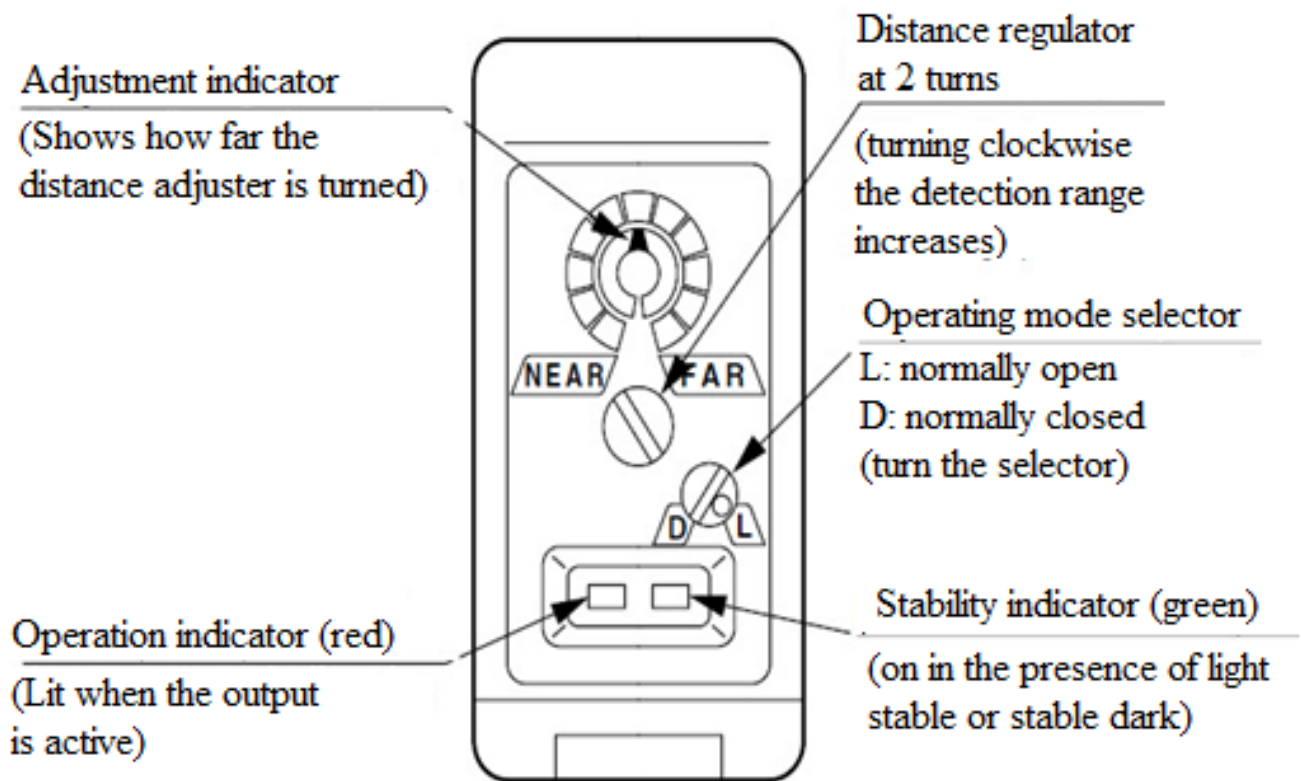

Set the “Operating mode selector” to L mode (turn the selector clockwise as far as it will go).

READING DISTANCE ADJUSTMENT

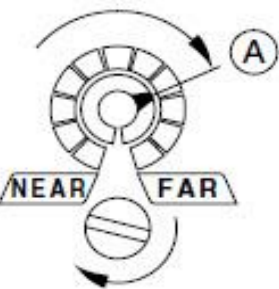
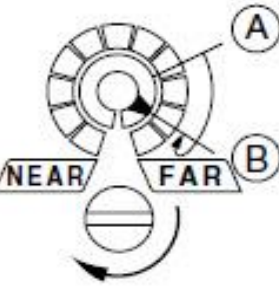
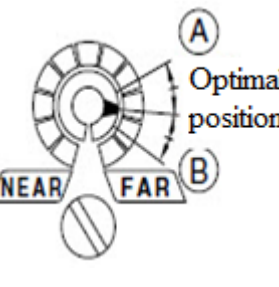
Description	Distance selector
<p>Turn completely the selector counter clock-wise direction in case of minimum distance (about 0.2mm).</p>	
<p>Locate the object to detect from the photocell (pallet centre) and turn the selector clock-wise direction till "A" to set the photocell in "light" condition (output active)</p>	
<p>Remove the a.m. object. Turn the selector in clock-wise direction till switch again the photocell to "light" condition. When it become on, turn again the selector to switch to "dark" to "B"</p> <p>(if absence of the object to detect the photocell do not switch to "light" condition ON, the "B" point must be considered like maximum point of the setting range).</p>	
<p>Set the selector to half range (middle between point "A" and point "B" that should be the best point to detect the object</p>	

60.2.109 rev. 01 – S7 standard -

PHOTOCELL FOR BLACK PRODUCTS S65

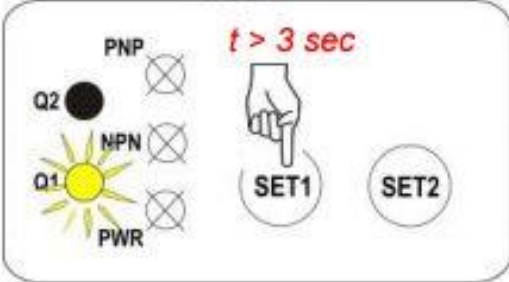
	<p>Place the target at the center of the pallet</p>
<p style="text-align: center;">Teach-In</p> 	<p>Keep pressed the Set1 button for more than 3 seconds, till the Q1 flashing</p>
	<p>Release the button, target detected</p>

R-CONNECT PHOTOCELL (only on P3GS PVS carriages)

	<p>Make sure it is turned on.</p> <p>Check / adjust that the trimmer is about halfway through the stroke.</p>
---	---

 Norm. Tecn. 60.2.113 rev. 00	TECHNICAL DOCUMENTATION ROBOT S7– Stop&Go	September 2022	Rev.04
	ENGLISH	Pag. 55 / 124	

60.2.109 rev. 01 – S7 standard -

“POWER SAVE” FUNCTION

after 15 minuts the machine turns to POWER SAVE mode --- > touch screen

AUTO POWER OFF FUNCTION

the machine turns off autonomously after the minutes written in the general parameter P [4]

default value P [4] = 30 ---> auto-off after 30 minutes

LITHIUM BATTERY AUTO POWER OFF

after 60 minuts when not in use, the LITHIUM battery also turns off



to turn the machine and the lithium battery back on, keep the selector pressed for 5 seconds

 Norm. Tecn. 60.2.113 rev. 00	TECHNICAL DOCUMENTATION ROBOT S7– Stop&Go	September 2022	Rev.04
	ENGLISH	Pag. 56 / 124	

60.2.109 rev. 01 – S7 standard -

BATTERY CHARGER SETTINGS



Enter with the SERVICE password 6161



Press

then press



The battery charge curve must be selected according to the type of battery used.

CHARGER

ACTUAL	COUNTER
Voltage <input style="width: 50px;" type="text" value="0"/>	Charge Total <input style="width: 50px;" type="text" value="0"/>
Current <input style="width: 50px;" type="text" value="0"/>	Charge Good <input style="width: 50px;" type="text" value="0"/>
Status <input style="width: 50px;" type="text" value="0"/>	deep discharge <input style="width: 50px;" type="text" value="0"/>
Time Charge <input style="width: 50px;" type="text" value="0"/>	error Temperature <input style="width: 50px;" type="text" value="0"/>
Energy Charged <input style="width: 50px;" type="text" value="0"/>	error Timeout <input style="width: 50px;" type="text" value="0"/>
Temperature <input style="width: 50px;" type="text" value="0"/>	lowBattery <input style="width: 50px;" type="text" value="0"/>
Model <input style="width: 50px;" type="text" value="0"/>	last Charge <input style="width: 50px;" type="text" value="0"/>
SW version <input style="width: 50px;" type="text" value="0"/>	qualityCharge <input style="width: 50px;" type="text" value="0"/>

Curve NOT DEFINED

Pb 90Ah

A

In the SEND section **(A)** select the charge curve according to the battery installed.



Once the battery is selected, press  then close the window.

Pb 90Ah	00L0605281
Pb 110 Ah 8 ore	0001346639 - 0001346706
Pb PURE	1760300042
Pb GENERIC	
Pb ENERSYS	
Pb RECOVERY	
AGM GEL	0001341436
LITHIUM	00L0553330

60.2.109 rev. 01 – S7 standard -

CHECK THE CURRENT DELIVERED in the CHARGE PHASE

For NORD ELETTRONICA battery charger connect it to the electrical socket and check that the **BATTERY CHARGER red LED** changes from **FLASHING** to **STEADY**

At the same time, the **CURRENT** parameter shown on the display must be greater than 10 A.

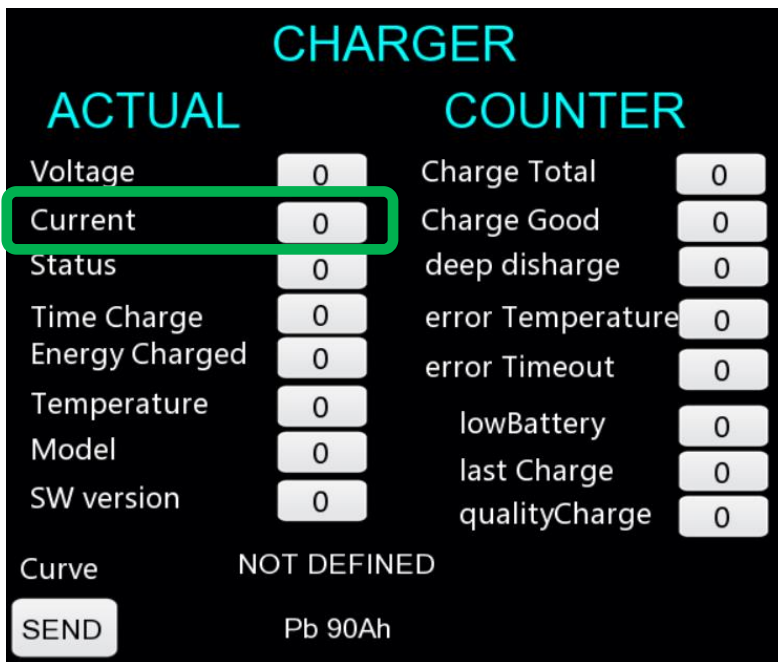

MEANING OF THE LEDS of the battery charger

- Flashing Red :

- Red :

- Yellow :

- Green :

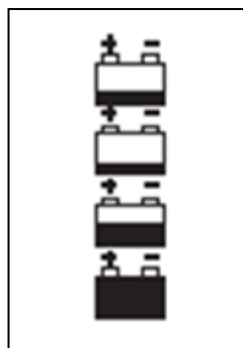

Battery status check phase

First charging phase

Second charging phase

Battery full / Maintenance phase

 Norm. Tecn. 60.2.113 rev. 00	TECHNICAL DOCUMENTATION ROBOT S7– Stop&Go	September 2022	Rev.04
	ENGLISH	Pag. 58 / 124	

60.2.109 rev. 01 – S7 standard -

BATTERYCHARGERS ALARMS

- **1 flash of the yellow led**: Battery disconnected or Polarity inversion or Output Short Circuit

--- > Check the connection to the battery

- **2 flashes of the yellow led**: Time-out alarm: faulty battery or battery capacity too high

--- > The alarm is reset by disconnecting the power supply. If it appears again, consult assistance.

- **3 flashes of the yellow led**: Battery charger faulty alarm

--- > The alarm is reset by disconnecting the power supply. If it appears again, consult assistance.

- **4 flashes of the yellow led**: Overtemperature alarm

--- > The alarm resets itself when the battery charger cools down. Check ventilation.

 Norm. Tecn. 60.2.113 rev. 00	TECHNICAL DOCUMENTATION ROBOT S7– Stop&Go	September 2022	Rev.04
	ENGLISH	Pag. 59 / 124	

60.2.109 rev. 01 – S7 standard -

“RECOVERY” CHARGING CURVE Lead Acid Battery

If you feel a deterioration in the performance of the **LEAD ACID Pb 90 Ah - Pb 110 Ah batteries**, probably related to the performance of NOT COMPLETE CHARGES

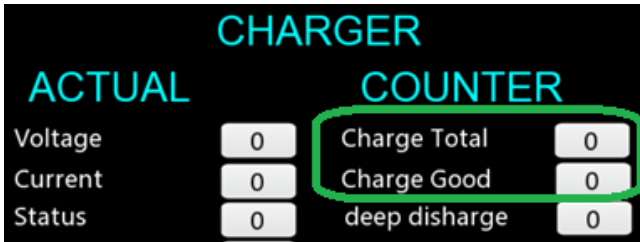

You can do a "RECOVERY" charge lasting about 24 hours (the green LED indicates the end of the charge)



to set this curve enter with the password SERVICE 6161





press

then press

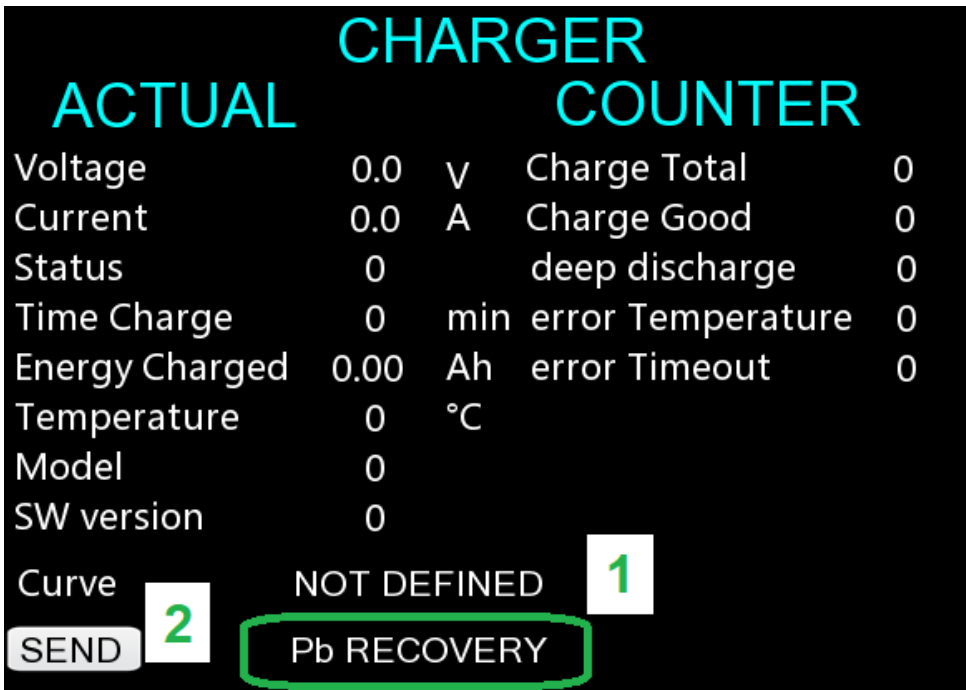

select the **Pb RECOVERY [1]** curve then **press SEND [2]**



 Norm. Tecn. 60.2.113 rev. 00	TECHNICAL DOCUMENTATION ROBOT S7– Stop&Go	September 2022	Rev.04
60.2.109 rev. 01 – S7 standard -	ENGLISH	Pag. 60 / 124	

“RECOVERY” CHARGING CURVE Lithium Battery

If you feel a deterioration in the performance of the **LITHIUM** batteries, you can perform a "RECOVERY" charge by following the procedure below

- 1) Turn on the machine
- 2) Disconnect the XS4 connector from the lithium battery

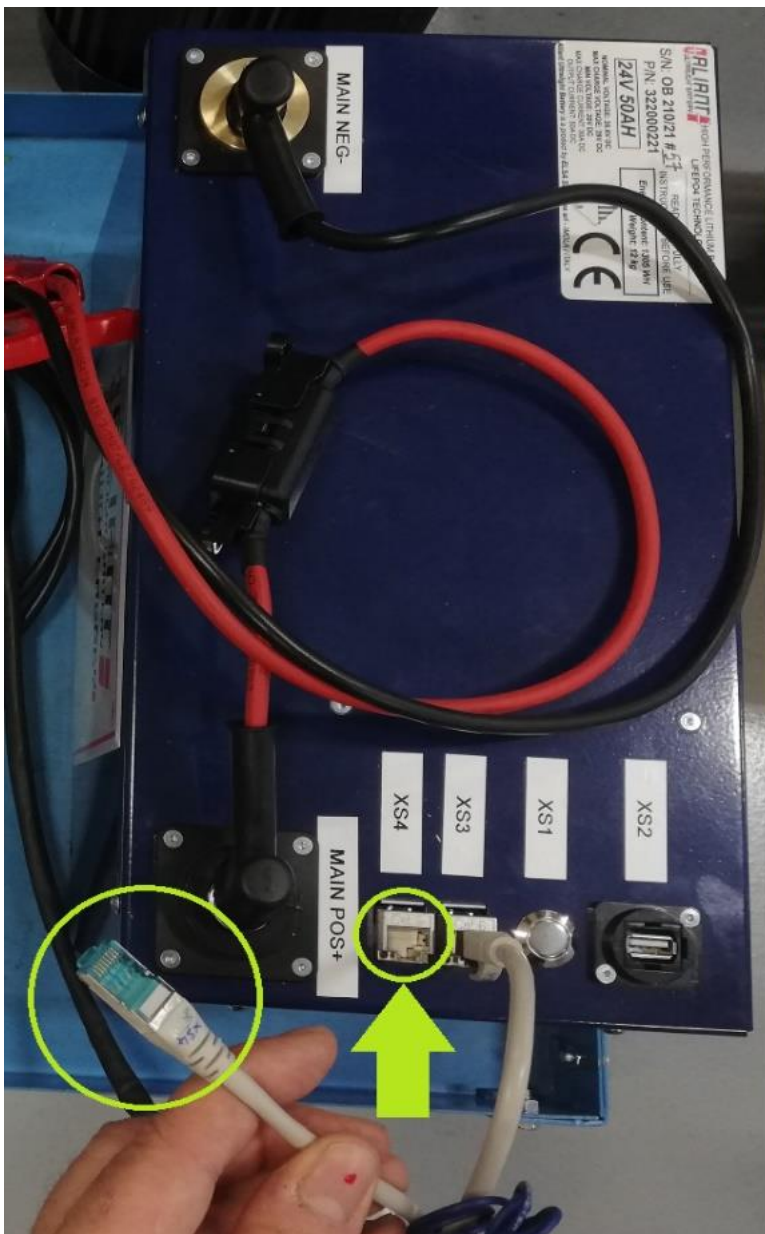

- 3) Power up the battery charger

 <p>Norm. Tecn. 60.2.113 rev. 00</p>	<p style="text-align: center;">TECHNICAL DOCUMENTATION ROBOT S7– Stop&Go</p> <p style="text-align: center;">ENGLISH</p>	<p>September 2022</p>	<p>Rev.04</p>
<p>60.2.109 rev. 01 – S7 standard -</p>		<p>Pag. 61 / 124</p>	

- 4) The green LED of the battery charger flashes



- 5) The yellow led of the battery charger starts flashing 5 times continuously



- 6) After about 1 minute the battery charger goes into "recovery mode" powering the battery with a low current
- 7) Leave the CHARGER plugged in for no less than **20 minutes**
- 8) Disconnect the battery charger
- 9) Reconnect the XS4 connector
- 10) Power the battery charger again and wait for the battery to fully charge (GREEN LED ON)

COMPARISON BETWEEN LITHIUM BATTERIES AND LEAD ACID BATTERIES

LITHIUM

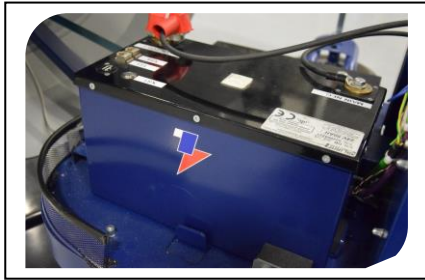

1) Greater cost
(x2)



2) Need specific
battery charger



3) Lower number of
wrapped pallets
(ex 140)



4) Possible QUICK recharges



5) No Maintenance needed
(no acid water inside)



LEAD ACID



Less cost



Need standard battery
charger (for acid, gel, AGM)



Greater number of
wrapped pallet
(ex 250)



QUICK recharges NOT
possible



Maintenance needed
(acid water required inside)



6) Weight reduced
(by up to 40%) 

Standard weight 

7) Longer life
(tip 2500 recharge cycles) 

Shorter life
(tip 500 recharge cycles) 

8) Does not release gas
when recharging 

Releases gas
when recharging 

9) Recharging requires
the machine to be turned on 

Recharging does not require
the machines to be turned on 

Lithium-ion batteries do not require the casing to be lifted.

Proceed as follows.

1. With the machine on, connect the supplied power cord to the IEC socket on the side of the machine.
2. Connect the other end of the cord to the power supply plug.

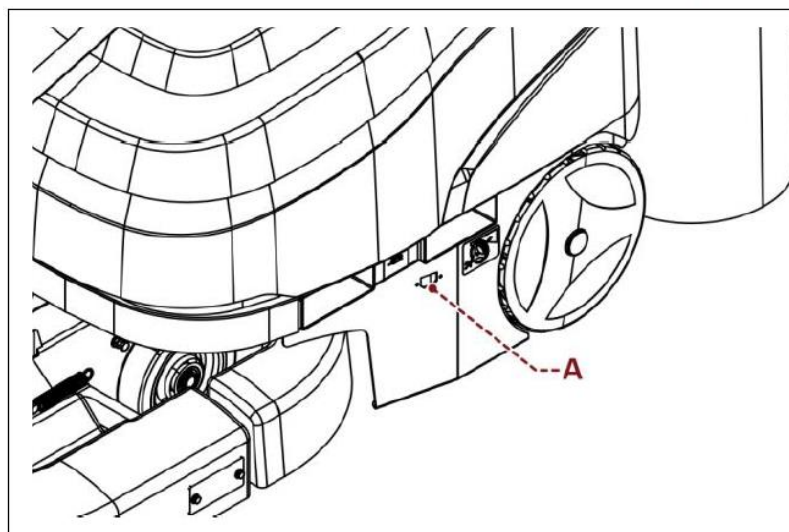

60.2.109 rev. 01 – S7 standard -

In case of NOT COMPLETE charge
 (green led of the battery charger NOT on)



The **LITHIUM** battery
 is **NOT damaged**

The **lead acid** battery
 is **damaged** prematurely



 Norm. Tecn. 60.2.113 rev. 00	TECHNICAL DOCUMENTATION ROBOT S7– Stop&Go	September 2022	Rev.04
	ENGLISH	Pag. 65 / 124	

60.2.109 rev. 01 – S7 standard -

NEW LITHIUM BATTERY with Keypad (from June 2022)

Lithium battery up to June 2022 (code 00L0553330)

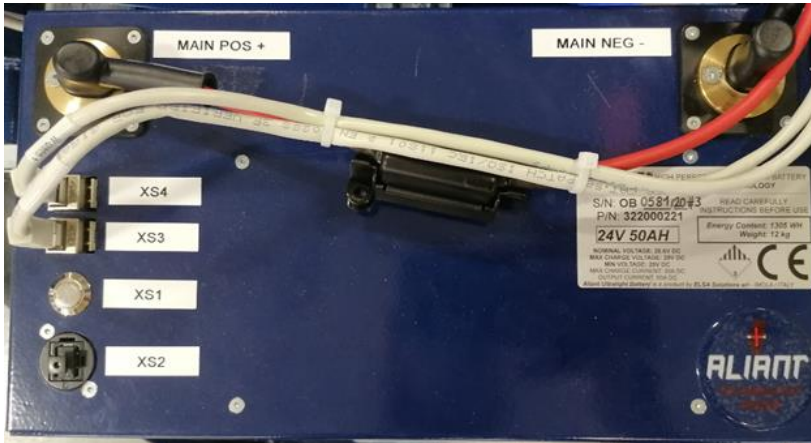

NEW Lithium BATTERY from June 2022 (code 1760300077) with Keypad

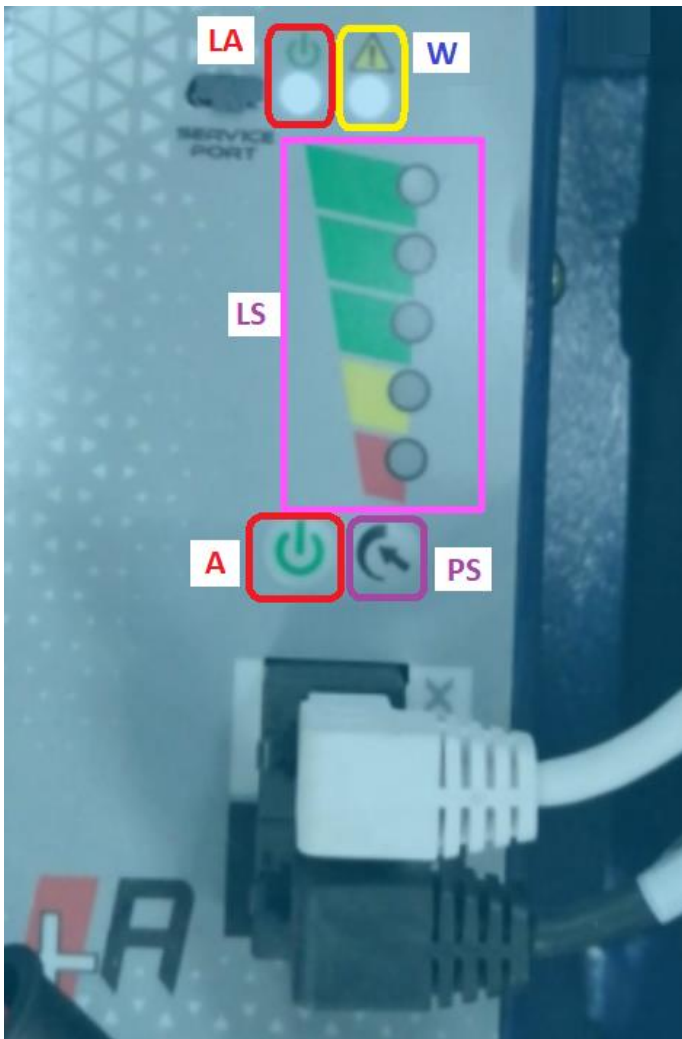

A = Key for possible independent power one

LA = Battery led on

PS = Battery level display key

LS = Battery level display LEDs

if the red LED is on --- >

low battery

W = Warning LED

on = empty battery

(state of charge equal to 0%)

 Norm. Tecn. 60.2.113 rev. 00	TECHNICAL DOCUMENTATION ROBOT S7– Stop&Go	September 2022	Rev.04
	ENGLISH	Pag. 66 / 124	

60.2.109 rev. 01 – S7 standard -

PROCEDURES FOR REPLACEMENT, SOFTWARE LOADING AND CALIBRATION OF ELECTRONIC BOARDS

TOUCH SCREEN PANEL

The TOUCH SCREEN is supplied as a spare WITHOUT SOFTWARE inside, in case it is necessary to replace or update the TOUCH SCREEN

Use the USB pen drive containing the original software versions which is supplied with the machine.



Robopac provides the original machine software with the USB 2.0 pen drive housed in the switchboard with all the technical machine documentation.

N.B.: In case it's necessary to create a new installation support (e.g: the original pen drive is lost) with a commercial pen drive:

- *use a USB 2.0 pen drive only*
- *copy the PLC board software files provided by Robopac at first directory level of pen drive*

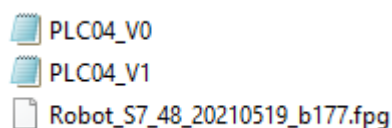

Example of software files

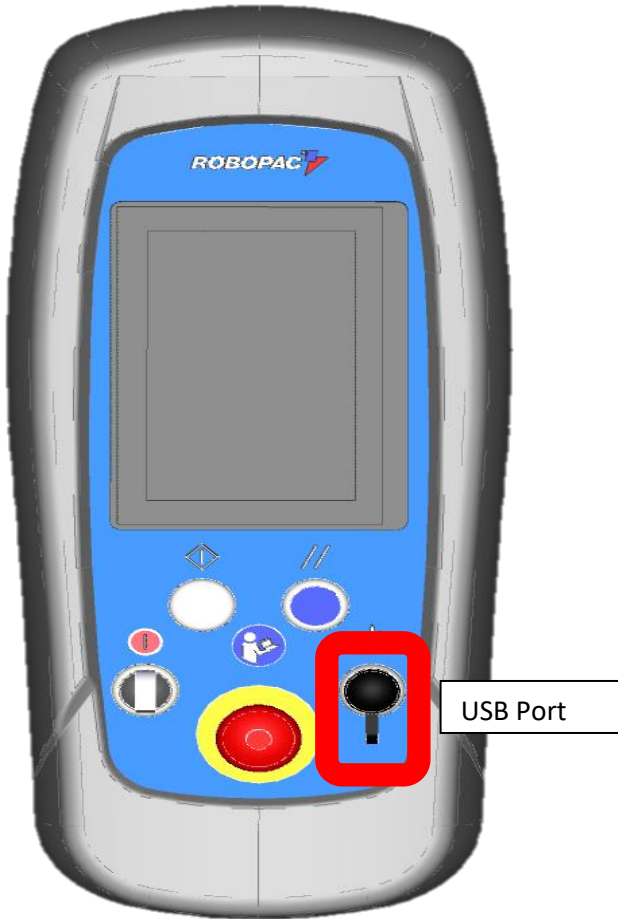

 Norm. Tecn. 60.2.113 rev. 00	TECHNICAL DOCUMENTATION ROBOT S7– Stop&Go	September 2022	Rev.04
	ENGLISH	Pag. 68 / 124	

60.2.109 rev. 01 – S7 standard -

New Installation

- Mechanically mount the touch-screen panel in place of the defective one
- Insert the SD card of the defective Touch Screen into the new Touch Screen

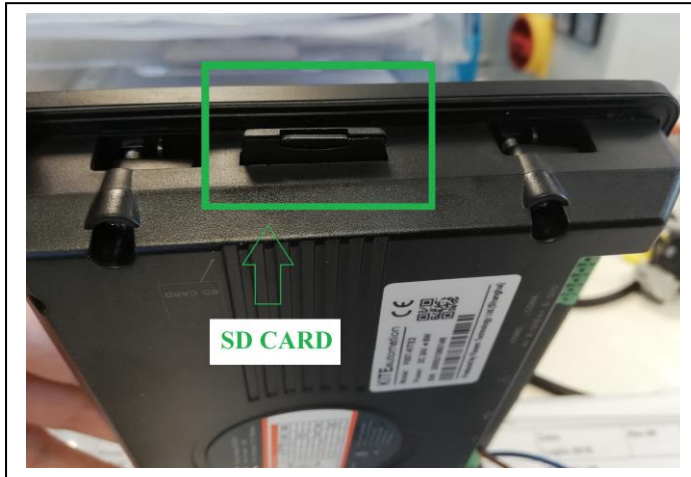

- Electrically wire the panel
- Turn on the machine and wait some seconds
- Insert the USB key into the port on the left of the HMI
- Select “Yes” in the popup window that is shown



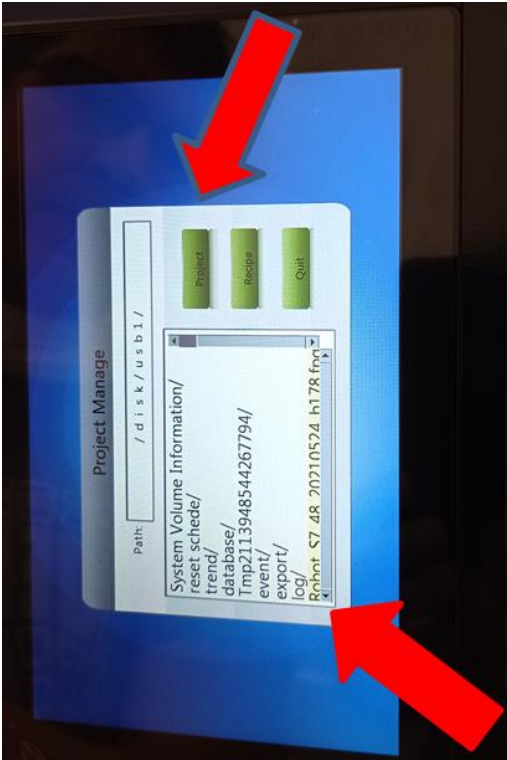

 <p>Norm. Tecn. 60.2.113 rev. 00</p>	<p align="center">TECHNICAL DOCUMENTATION ROBOT S7– Stop&Go</p> <p align="center">ENGLISH</p>	<p align="center">September 2022</p>	<p align="center">Rev.04</p>
<p>60.2.109 rev. 01 – S7 standard -</p>	<p align="right">Pag. 69 / 124</p>		

- Select the file **ROBOT S7 xxxxxxxxxxxx** then press **“Project”**

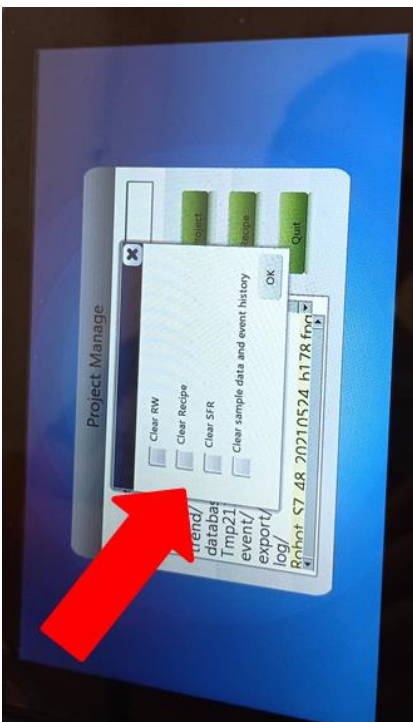

- Activate all the ticks then press OK



 Norm. Tecn. 60.2.113 rev. 00	TECHNICAL DOCUMENTATION ROBOT S7– Stop&Go	September 2022	Rev.04
	ENGLISH	Pag. 70 / 124	

60.2.109 rev. 01 – S7 standard -

- At the end of the software download, the panel restarts the application

if the white screen appears, follow the procedure indicated:

(probably the USB key was removed too soon while programming the panel)

PANEL reset procedure:

- SWITCH ON THE MACHINE
- KEEP THE CENTER OF THE PANEL PRESSED WITH A FINGER
- THE TOUCH "MENU" OPENS



- Press SETUP
- Press PROJECT and enter the PASSWORD 888888
- REPEAT THE PROGRAM WRITING PROCEDURE FROM THE BEGINNING

 <p>Norm. Tecn. 60.2.113 rev. 00</p>	<p align="center">TECHNICAL DOCUMENTATION ROBOT S7– Stop&Go</p> <p align="center">ENGLISH</p>	<p align="center">September 2022</p>	<p align="center">Rev.04</p>
		<p align="center">Pag. 71 / 124</p>	

60.2.109 rev. 01 – S7 standard -

- Press “START” to update the software in the PLC on the pre-stretch carriage



- Once the machine has restarted, this page appears. Turn the machine off and on again.

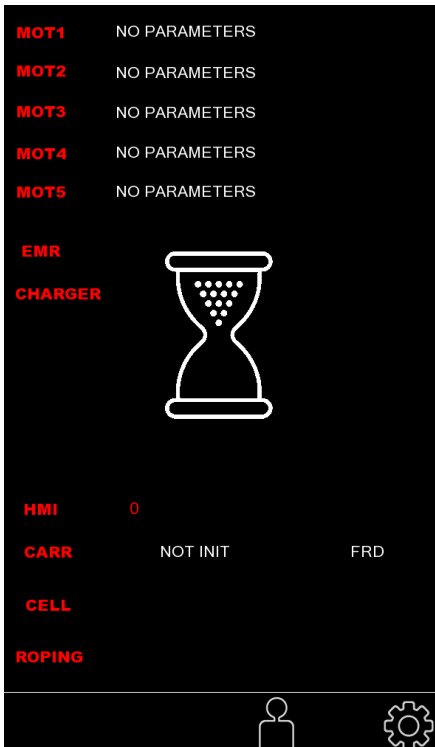

At the end of the REPLACEMENT and insertion of the software in the TOUCH SCREEN

IT IS NECESSARY to do

 Norm. Tecn. 60.2.113 rev. 00	TECHNICAL DOCUMENTATION ROBOT S7– Stop&Go	September 2022	Rev.04
60.2.109 rev. 01 – S7 standard -	ENGLISH	Pag. 72 / 124	

(1) The default of the CONFIGURATION PARAMETERS



and subsequent RE-CONFIGURATION of the ROBOT

(2) The default of the CARRIAGE PARAMETERS



and subsequent RE-CONFIGURATION of the CARRIAGE PARAMETERS

(3) Default of RECIPES



 Norm. Tecn. 60.2.113 rev. 00	TECHNICAL DOCUMENTATION ROBOT S7– Stop&Go	September 2022	Rev.04
	ENGLISH	Pag. 73 / 124	

60.2.109 rev. 01 – S7 standard -

Software Update



Enter with the Customer Manager password **1111**



Access the service page and then to the



page

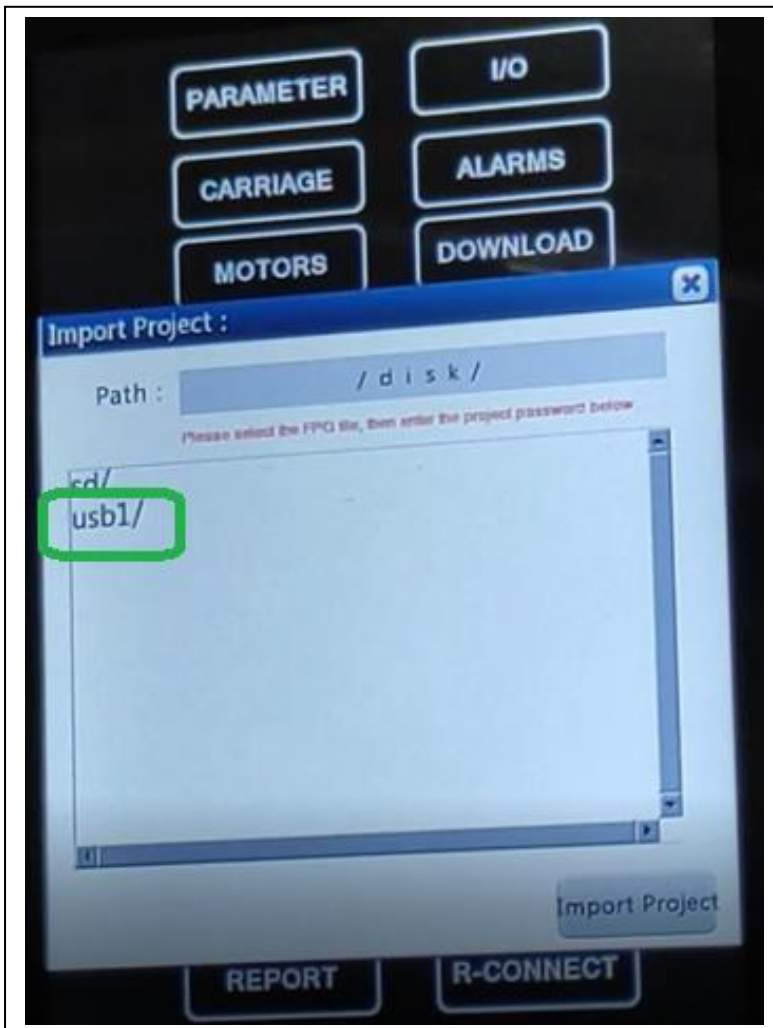

Select usb1/

60.2.109 rev. 01 – S7 standard -

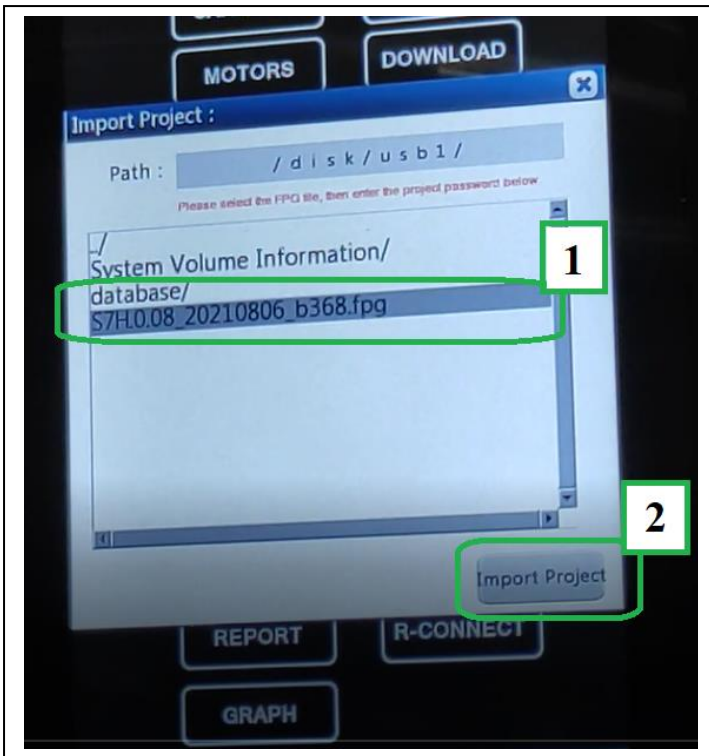

[1] Select the file **fpg**

PLC04_V0

PLC04_V1

Robot_S7_48_20210519_b177.fpg

[2] press **Import Project**

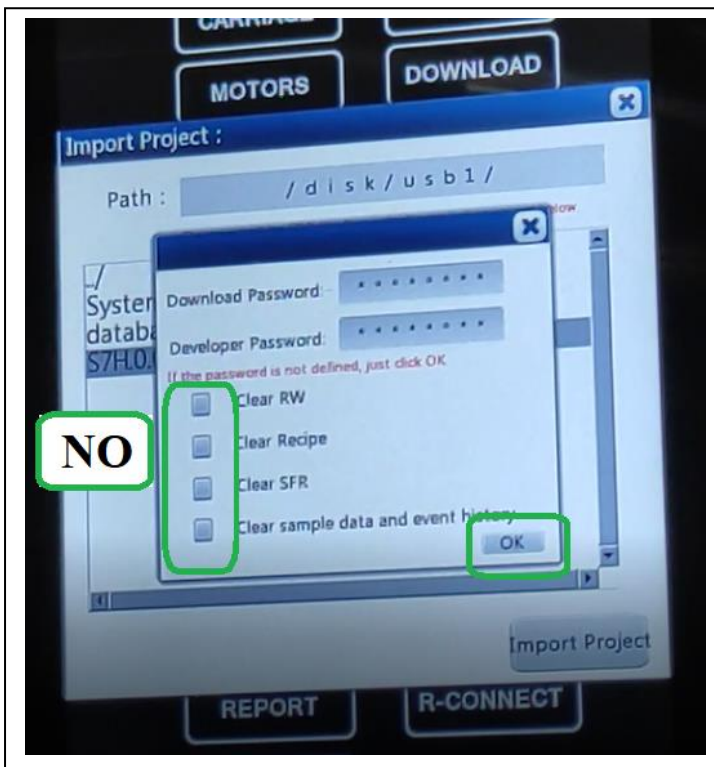

[OK] press **OK**

Without ticking ANYTHING

60.2.109 rev. 01 – S7 standard -

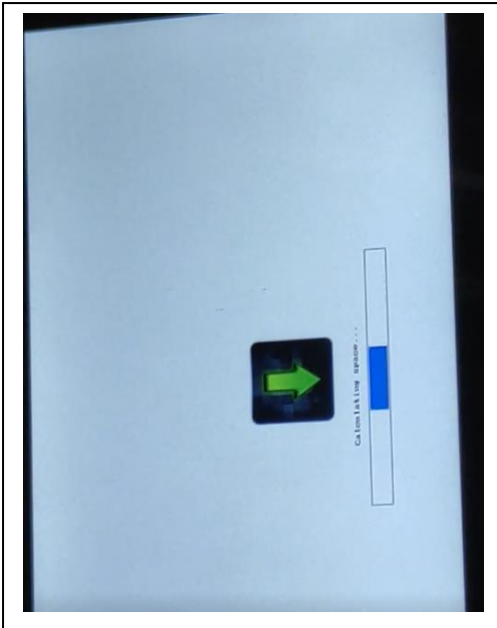

The software is downloaded ...



Operation Concluded

At the end of the simple software UPDATE in the TOUCH SCREEN

IT IS NOT NECESSARY to do other operations on the parameters

 Norm. Tecn. 60.2.113 rev. 00	TECHNICAL DOCUMENTATION ROBOT S7– Stop&Go	September 2022	Rev.04
	ENGLISH	Pag. 76 / 124	

60.2.109 rev. 01 – S7 standard -

PLC BOARD mounted in the electrical panel (U500)

The PLC is supplied as a spare WITHOUT SOFTWARE inside, in case it is necessary to replace or update the PLC

Use the USB pen drive containing the original software versions which is supplied with the machine.



Robopac provides the original machine software with the USB 2.0 pen drive housed in the switchboard with all the technical machine documentation.

N.B.: In case it's necessary to create a new installation support (e.g: the original pen drive is lost) with a commercial pen drive:

- *use a USB 2.0 pen drive only*
- *copy the PLC board software files provided by Robopac at first directory level of pen drive*

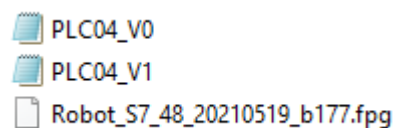

Example of software files

60.2.109 rev. 01 – S7 standard -

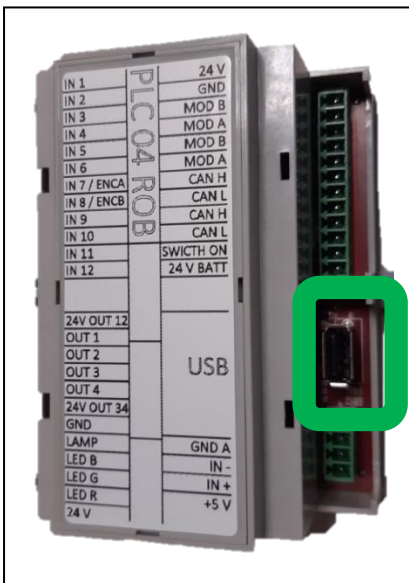
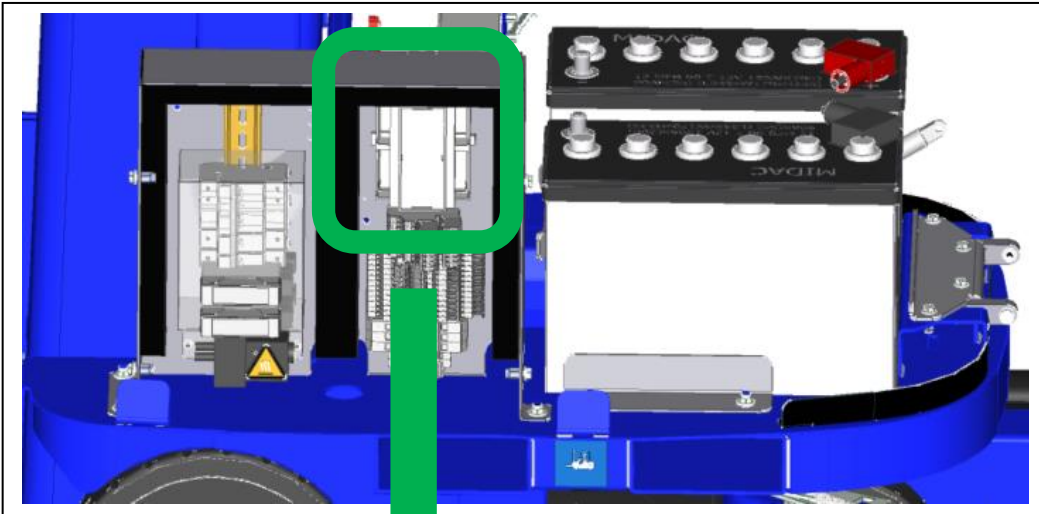

USB Port

WHITE LED = plc OK

- With the machine off, insert the USB key into the appropriate port
- Turn on the machine
- The LED next to the USB port emits a blue flash during the software download
- Once the download has been completed successfully, the LED turns flashing white or red in the event of an alarm
- Remove the USB key

60.2.109 rev. 01 – S7 standard -

- Check that you have all DIP SWITCHES ON and only N.2 OFF

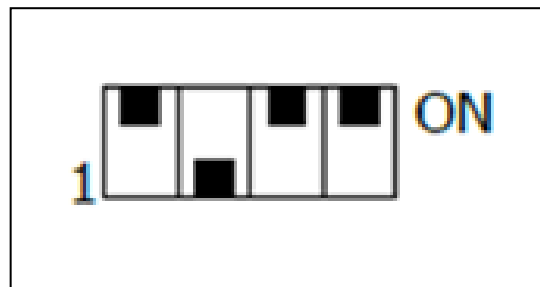
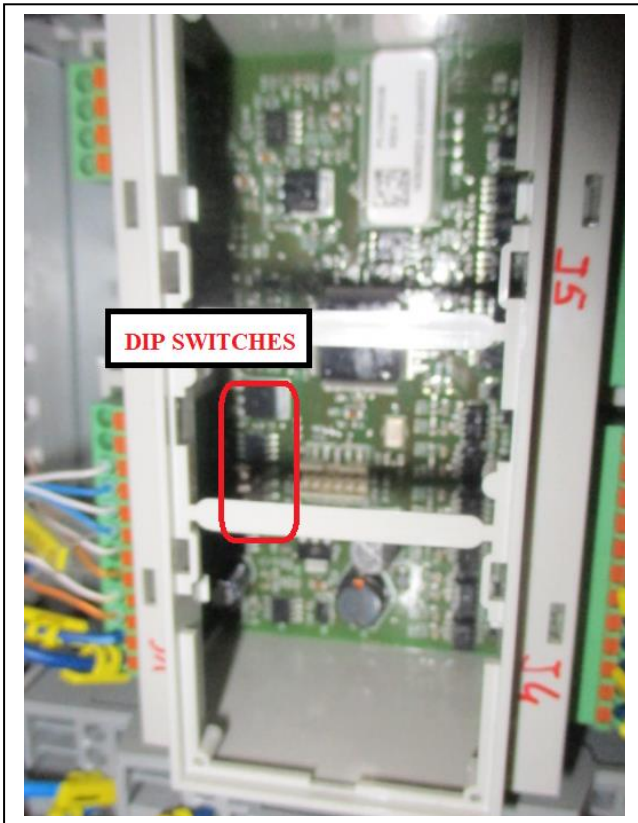

Write the MOTORS parameters

- For the modification the password 6161 is required



- Press on



Press



to write the panel parameters to the memory

The "W" button becomes **RED** to indicate the writing then becomes **GREEN** as confirmation of the end of writing

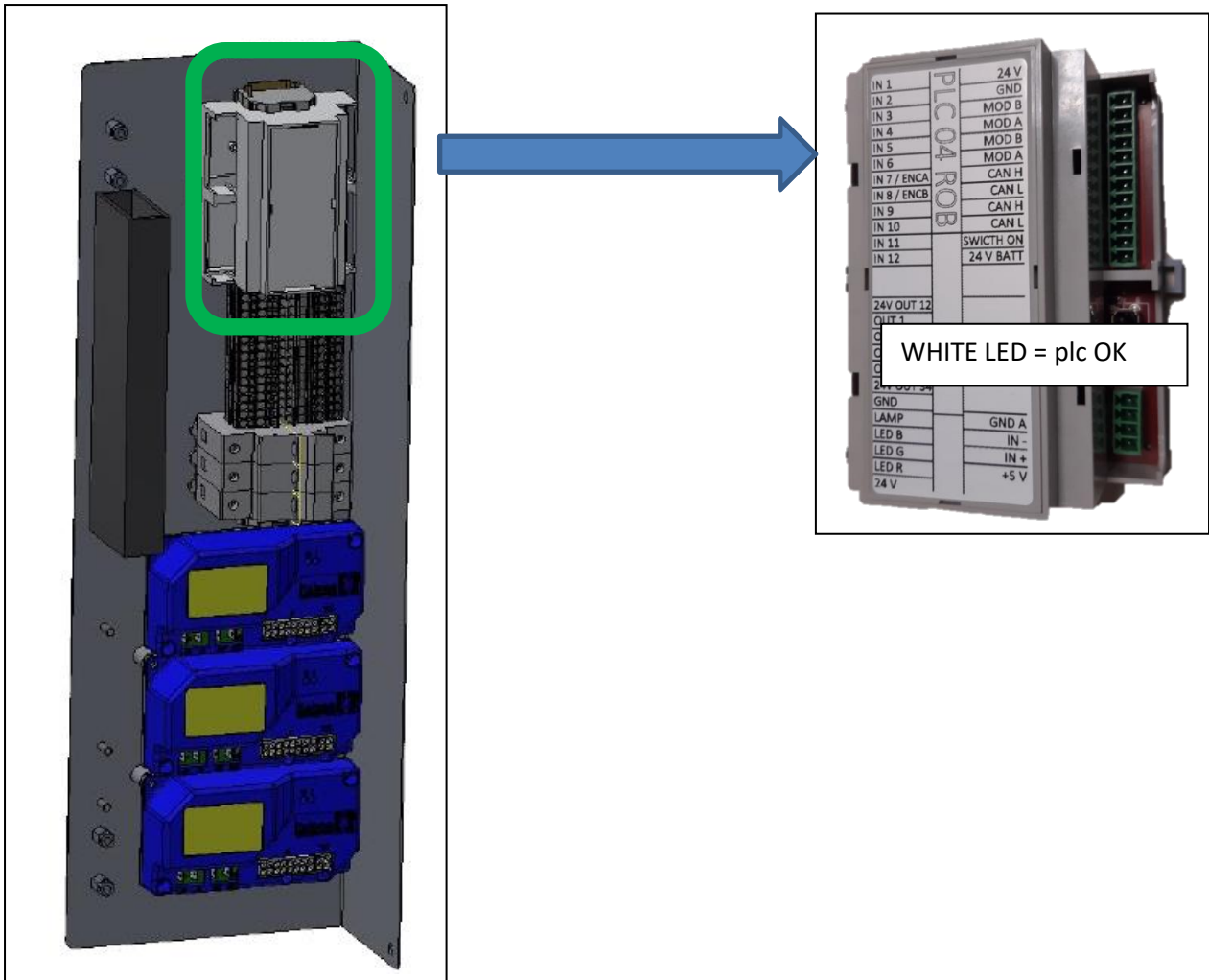
PLC BOARD mounted on the carriage (U550)

- With the machine off, insert the USB key into the appropriate port
- Turn on the machine
- The LED next to the USB port emits a blue flash during the software download
- Once the download has been completed successfully, the LED turns flashing white or red in the event of an alarm
- Remove the USB key

 Norm. Tecn. 60.2.113 rev. 00	TECHNICAL DOCUMENTATION ROBOT S7– Stop&Go	September 2022	Rev.04
60.2.109 rev. 01 – S7 standard -	ENGLISH	Pag. 80 / 124	

- Check that you have all DIP SWITCHES ON

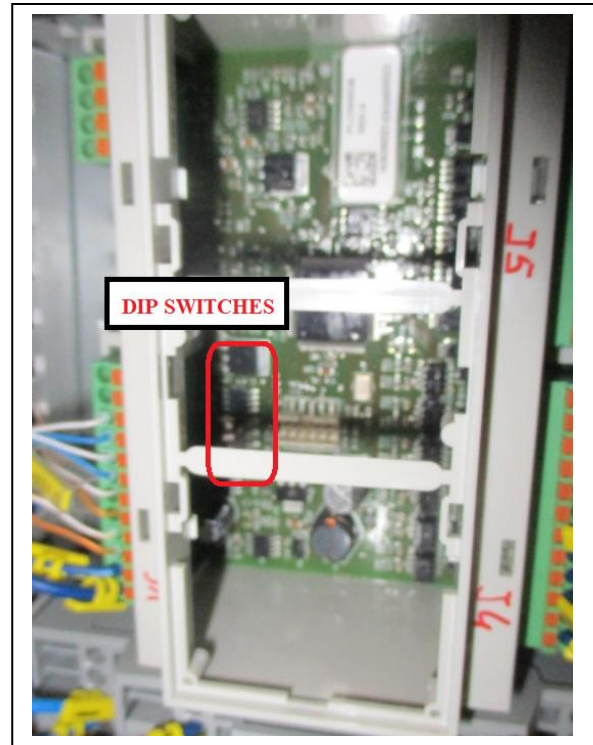
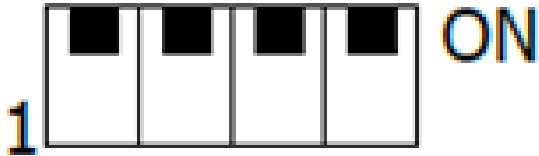

Write the CARRIAGE parameters



- For the modification the password 6161 is required



- Press on



Press  to write the panel parameters to the memory

The “W” button becomes **RED** to indicate the writing then becomes **GREEN** as confirmation of the end of writing

 Norm. Tecn. 60.2.113 rev. 00	TECHNICAL DOCUMENTATION ROBOT S7– Stop&Go	September 2022	Rev.04
ENGLISH		Pag. 81 / 124	

60.2.109 rev. 01 – S7 standard -

Write the MOTORS parameters



- For the modification the password 6161 is required



- Press on



Press

to write the panel parameters to the memory

The “W” button becomes **RED** to indicate the writing then becomes **GREEN** as confirmation of the end of writing

Perform the CALIBRATION of the LOAD CELL

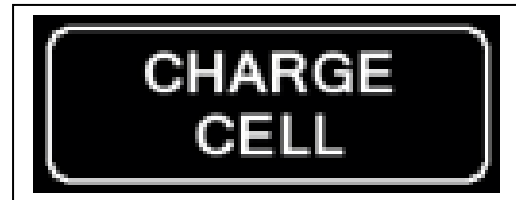

Perform the VARIABLE ROPING CALIBRATION/SETTING



 Norm. Tecn. 60.2.113 rev. 00	TECHNICAL DOCUMENTATION ROBOT S7– Stop&Go	September 2022	Rev.04
	ENGLISH	Pag. 82 / 124	

60.2.109 rev. 01 – S7 standard -

Motor DRIVERS REPLACEMENT

TRACTION MOTOR DRIVER

In the case of replacement of the traction group MOTOR + GEAR BOX + BRAKE + DRIVER (A201)

(code 2210300049)

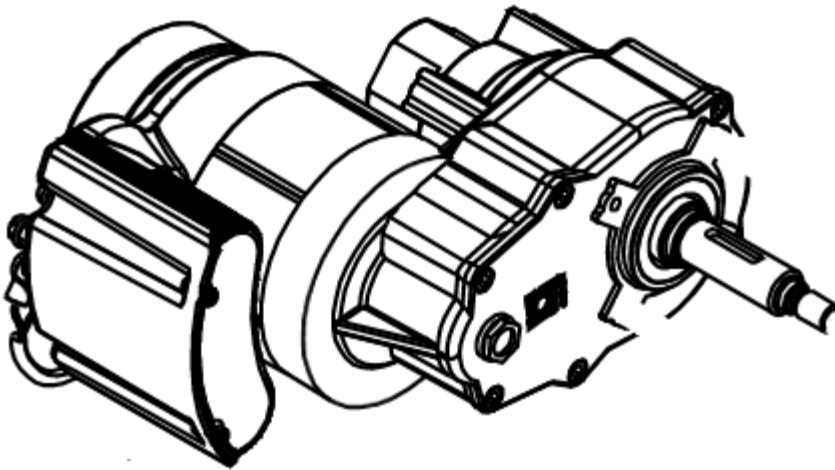

The only operation to be performed on the parameters is:

Write the MOTORS parameters

- For the modification the password 6161 is required



- Press on



Press





to write the panel parameters to the memory

The “W” button becomes **RED** to indicate the writing then becomes **GREEN** as confirmation of the end of writing

60.2.109 rev. 01 – S7 standard -

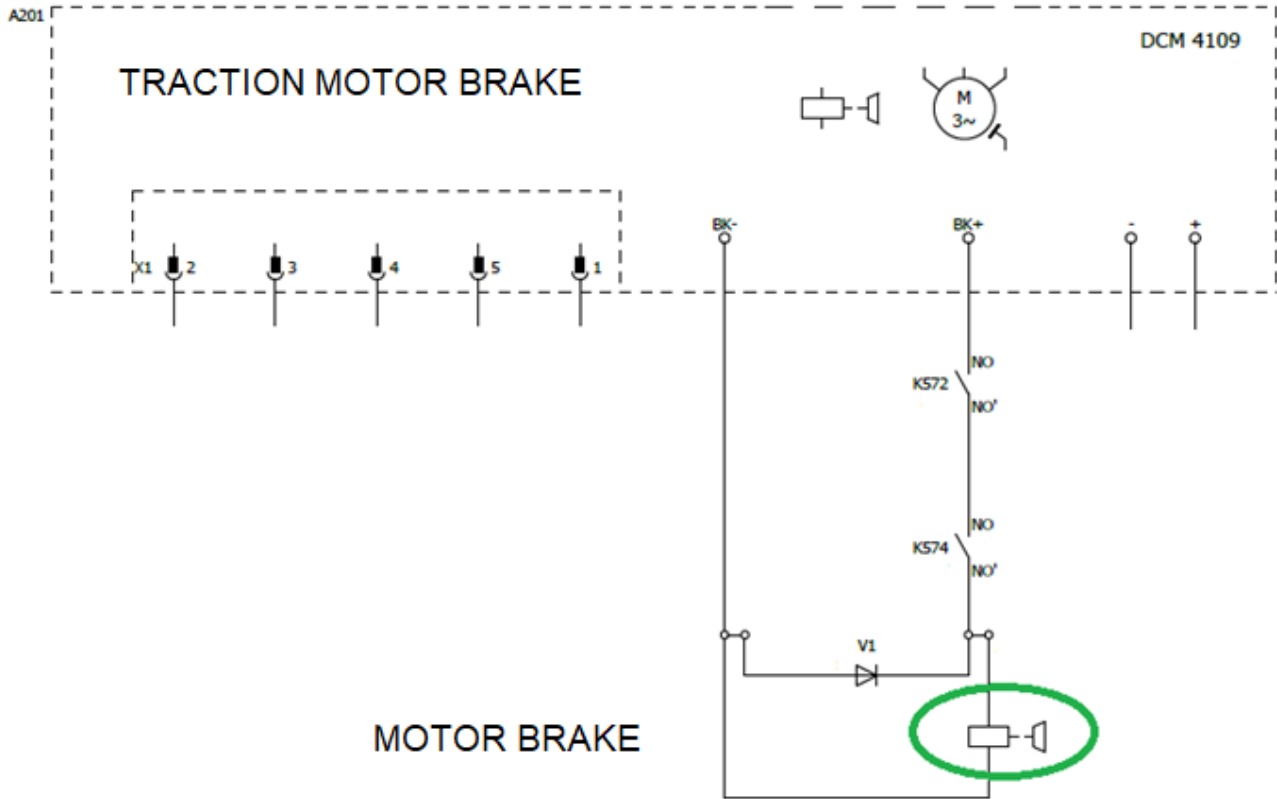
ATTENTION to the presence of the TRACTION MOTOR BRAKE



 Norm. Tecn. 60.2.113 rev. 00	TECHNICAL DOCUMENTATION ROBOT S7– Stop&Go	September 2022	Rev.04
	ENGLISH	Pag. 84 / 124	

60.2.109 rev. 01 – S7 standard -

Up / down CARRIAGE MOTOR DRIVER

In the case of replacement of the up/down carriage group MOTOR + DRIVER (A251)

(code 2210300068)

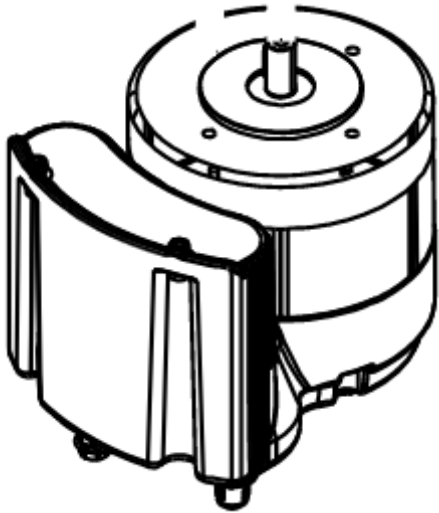

The only operation to be performed on the parameters is:

Write the MOTORS parameters

- For the modification the password 6161 is required



- Press on



Press



to write the panel parameters to the memory

The “W” button becomes **RED** to indicate the writing then becomes **GREEN** as confirmation of the end of writing

60.2.109 rev. 01 – S7 standard -

DRIVERS PRESENT on the FILM SPOOL CARRIAGE

3 drives with the same CODE can be mounted on the carriage (code 00L0639095)

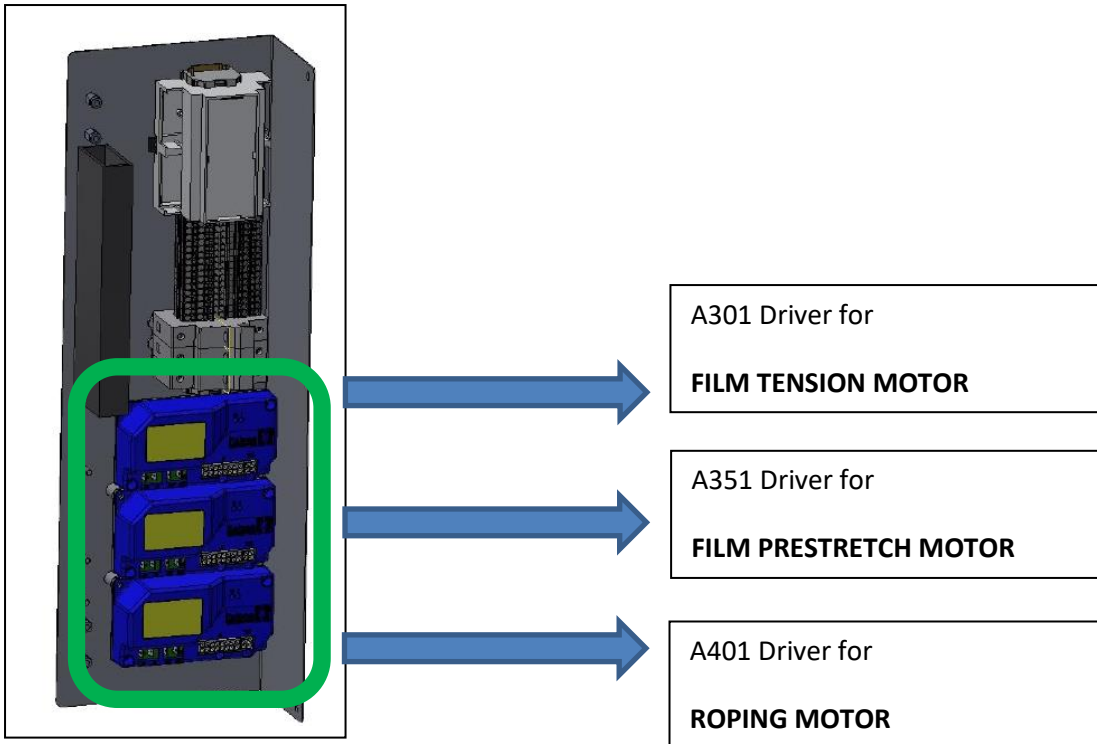

In the case of **REPLACEMENT**, the only operation to be performed on the parameters is:

Write the MOTORS parameters

- For the modification the password 6161 is required



- Press on



Press

to write the panel parameters to the memory

The “W” button becomes **RED** to indicate the writing then becomes **GREEN** as confirmation of the end of writing

60.2.109 rev. 01 – S7 standard -

REAR SAFETY SYSTEM COMPONENTS (laser scanner)

LASER SCANNER



In the case of **REPLACEMENT**, the only operation to be performed is:

LOADING the **SOFTWARE** into the **MODULE** ---> by **ROBOPAC ONLY**



SAFETY CONTROL UNIT



A567 Mosaic MV0

unità di espansione sensori di prossimità

A564 Mosaic MI802

unità di espansione I/O (8 ingressi / 2 OSSD doppie)

A560 Mosaic M1S

unità principale (8 ingressi / 4 OSSD singole)

In the case of **REPLACEMENT** of **ONE / TWO** or **ALL THREE** modules, the only operation to be performed is:

LOADING the **SOFTWARE** into the **MODULE** ---> by **ROBOPAC ONLY**

60.2.109 rev. 01 – S7 standard -

PLC BOARDS DESCRIPTION (PLC04ROB)

PLC BOARD mounted on the ELECTRICAL BOX (U500)

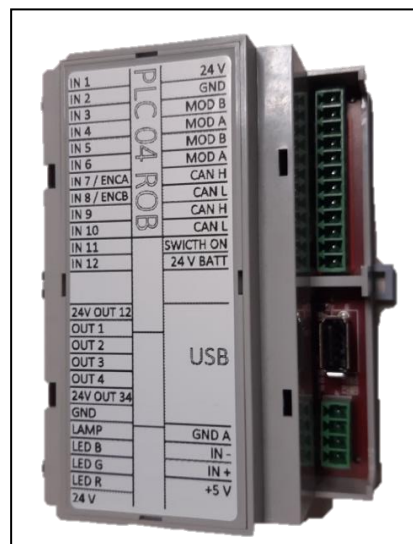
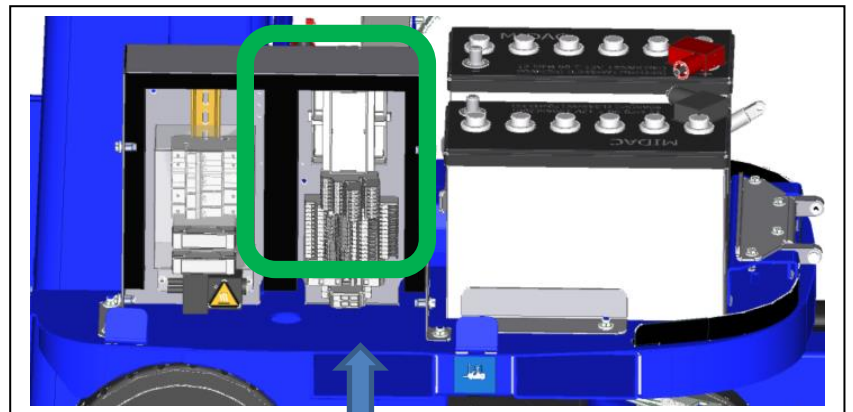

60.2.109 rev. 01 – S7 standard -



60.2.109 rev. 01 – S7 standard -

Connector	PIN	Signal	Meaning of the Inputs
J4	1	IN1	START Button
J4	2	IN2	Steering wheel Alarm
J4	3	IN3	RESET Button
J4	4	IN4	Emergency Button
J4	5	IN5	Emergency Bumper
J4	6	IN6	Emergency Feedback
J4	7	IN7	Traction Motor Encoder channel A
J4	8	IN8	Traction Motor Encoder channel B
J4	9	IN9	Manual Forward
J4	10	IN10	Manual Backward
J4	11	IN11	Free
J4	12	IN12	Free
Connector	PIN	Signal	Meaning of the Outputs
J5	1	24V_OUT1/2	+24VDC (for OUT1 and OUT2)
J5	2	OUT1	Auto Power OFF
J5	3	OUT2	Emergency Feedback
J5	4	OUT3	Free
J5	5	OUT4	Siren
J5	6	24V_OUT3/4	+24VDC (for OUT3 and OUT4)
J5	7	GND	Free
J5	8	LAMP	Blue Light
J5	9	B	Circulat Optical Lamp
J5	10	G	Circulat Optical Lamp
J5	11	R	Circulat Optical Lamp
J5	12	2+	Circulat Optical Lamp
Connector	PIN	Signal	Meaning of the Signals
J1	12	2+	Positive Power Supply 24VDC (+)
J1	11	GND	Negative Power Supply 0VDC (-)
J1	10	MODB	Communication with Touch Screen
J1	9	MODA	Communication with Touch Screen
J1	8	MODB	Communication Carriage PLC – Batterycharger – Battery Level
J1	7	MODA	Communication Carriage PLC – Batterycharger – Battery Level
J1	6	GND	Communication with Lithium Battery (optional)
J1	5	CANH	Communication with Lithium Battery (optional)
J1	4	CANL	Communication with Traction Driver
J1	3	GND	Communication with Traction Driver
J1	2	SWH_ON	Free
J1	1	24V_BATT	Free
Connector	PIN	Signal	Meaning of the Signals
J2	4	GNDA	Free
J2	3	IN-	Free
J2	2	IN+	Free
J2	1	+V_AN	Free

60.2.109 rev. 01 – S7 standard -

PLC BOARD mounted on the CARRIAGE (U550)

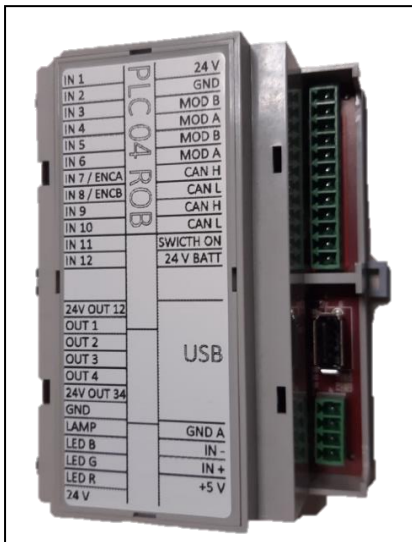
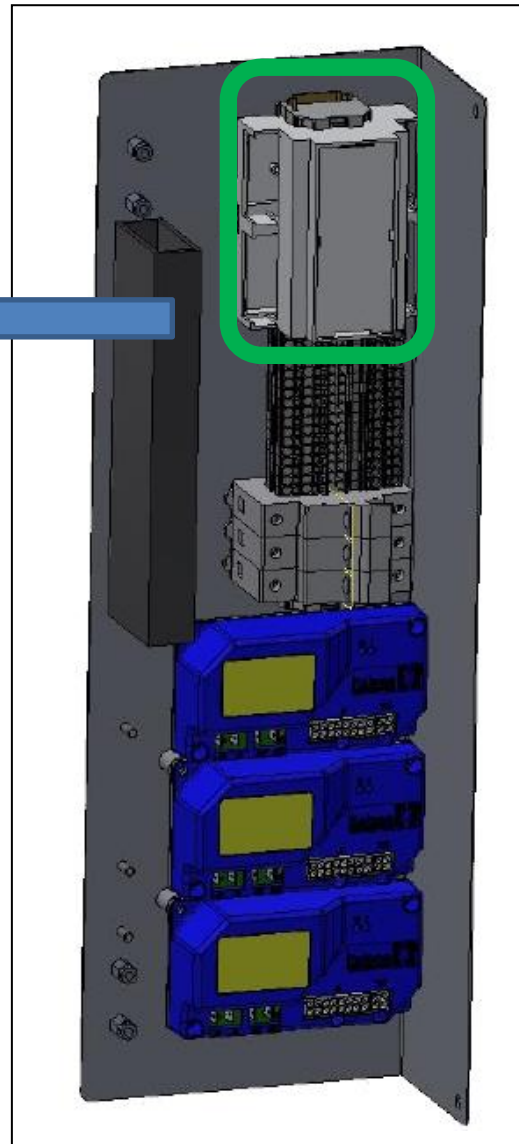
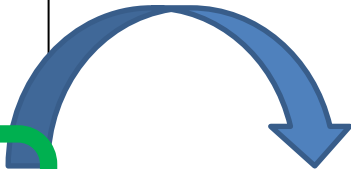

60.2.109 rev. 01 – S7 standard -

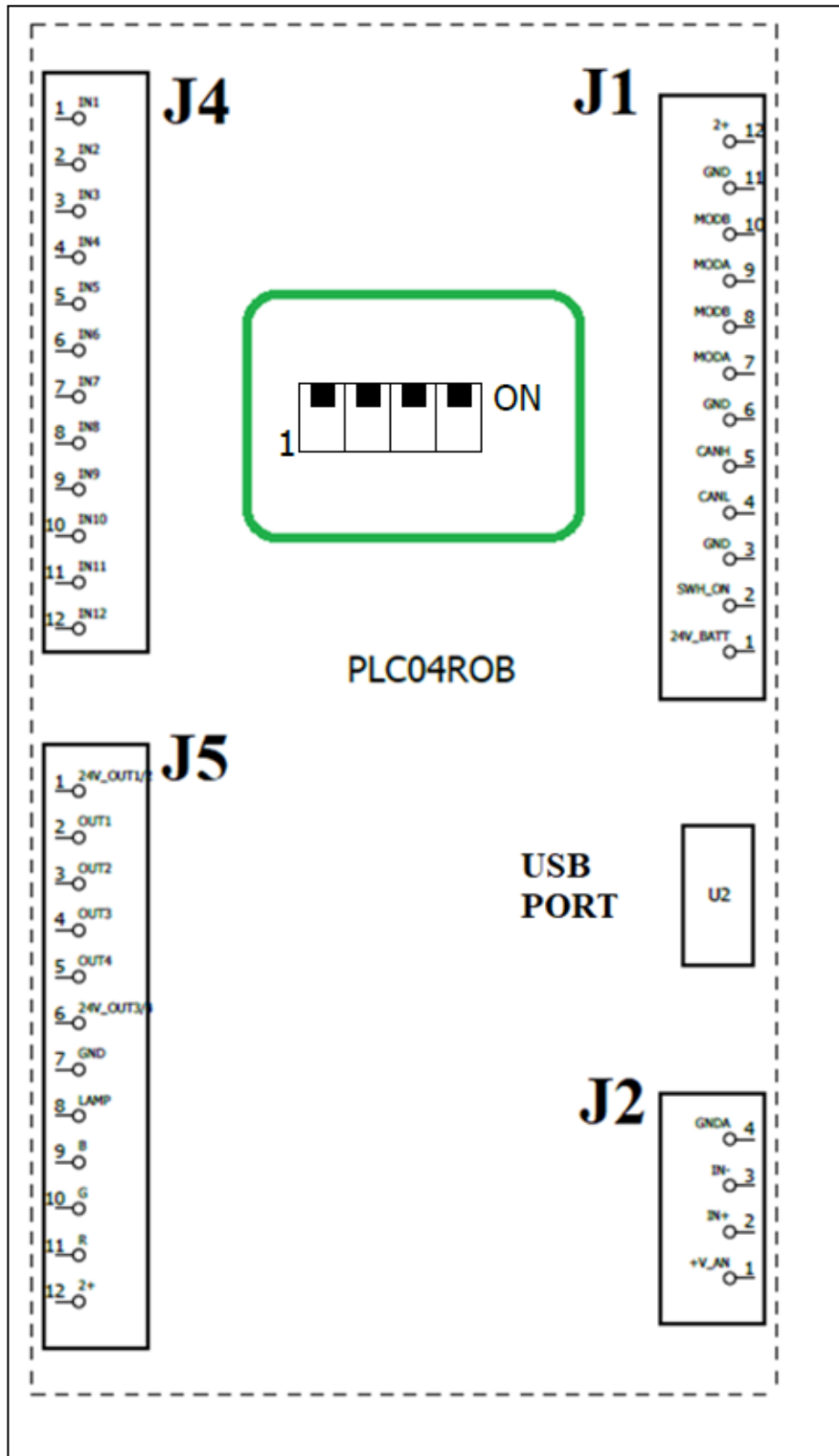

60.2.109 rev. 01 – S7 standard -

Connector	PIN	Signal	Meaning of the Inputs
J4	1	IN1	Pallet Height Photocell
J4	2	IN2	Unwinding Film Sensor (optional)
J4	3	IN3	Unwinding Film Button
J4	4	IN4	Top Microswitch
J4	5	IN5	Bottom Microswitch
J4	6	IN6	Carriage Door Opening
J4	7	IN7	Top Roping (optional)
J4	8	IN8	Bottom Roping (optional)
J4	9	IN9	Carriage Casing Opening
J4	10	IN10	Free
J4	11	IN11	Free
J4	12	IN12	Free
Connector	PIN	Signal	Meaning of the Outputs
J5	1	24V_OUT1/2	+24VDC (for OUT1 and OUT2)
J5	2	OUT1	Free
J5	3	OUT2	Film Cut (optional)
J5	4	OUT3	Driver Enable
J5	5	OUT4	Free
J5	6	24V_OUT3/4	+24VDC (for OUT3 and OUT4)
J5	7	GND	Free
J5	8	LAMP	Free
J5	9	B	Free
J5	10	G	Free
J5	11	R	Free
J5	12	2+	Free
Connector	PIN	Signal	Meaning of the Signals
J1	12	2+	Positive Power Supply 24VDC (+)
J1	11	GND	Negative Power Supply 0VDC (-)
J1	10	MODB	Communication BOX PLC – Batterycharger – Battery Level
J1	9	MODA	Communication BOX PLC – Batterycharger – Battery Level
J1	8	MODB	Free
J1	7	MODA	Free
J1	6	GND	Communication Roping Driver (optional)
J1	5	CANH	Communication Roping Driver (optional)
J1	4	CANL	Communication Carriage Motors Drivers (P3GS / PVS)
J1	3	GND	Communication Carriage Motors Drivers (P3GS / PVS)
J1	2	SWH_ON	Free
J1	1	24V_BATT	Free
Connector	PIN	Signal	Meaning of the Signals
J2	4	GNDA	Load Cell
J2	3	IN-	Load Cell
J2	2	IN+	Load Cell
J2	1	+V_AN	Load Cell

60.2.109 rev. 01 – S7 standard -

DESCRIPTION of the LASER SCANNER - S7 - 16V -

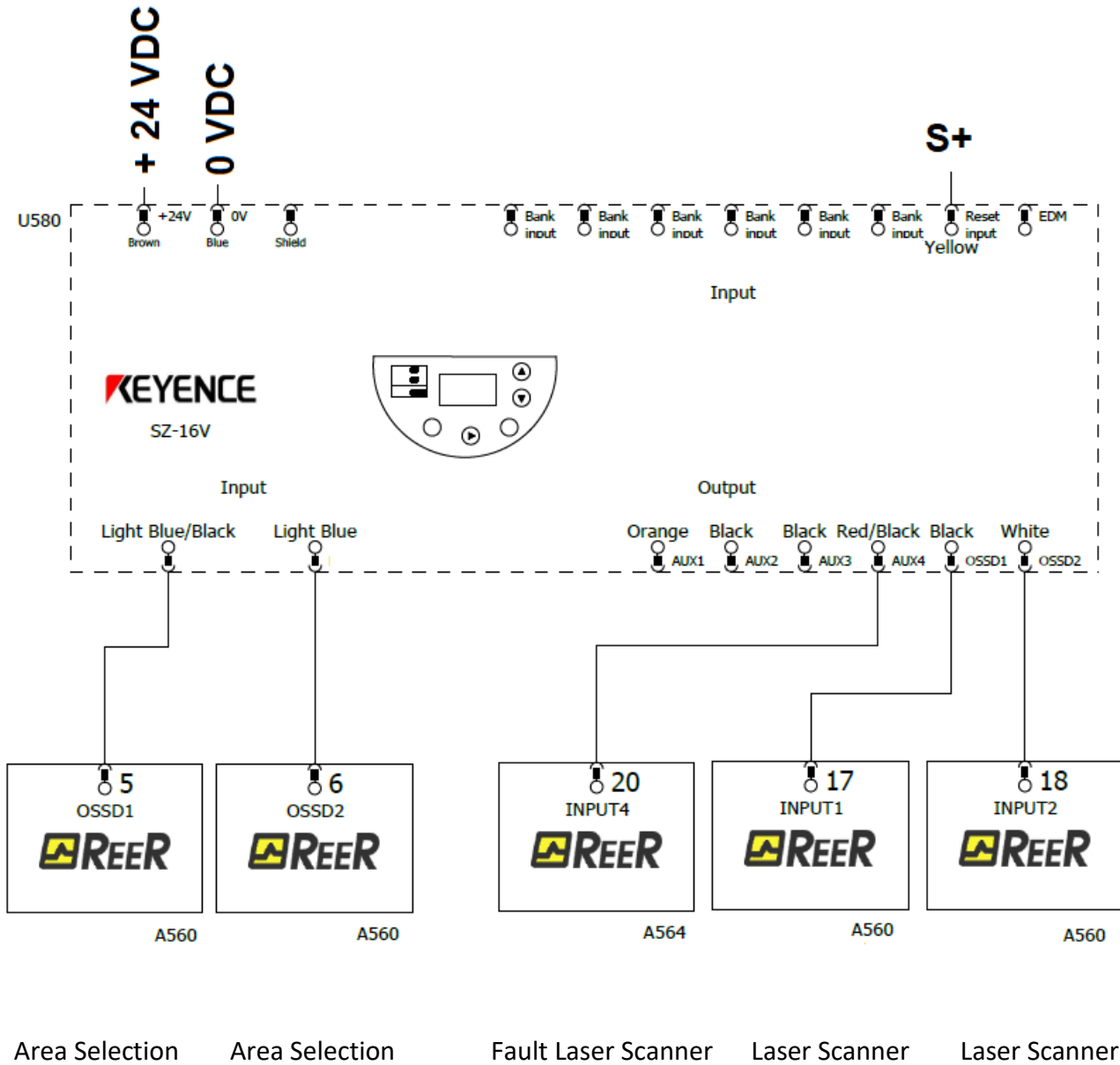

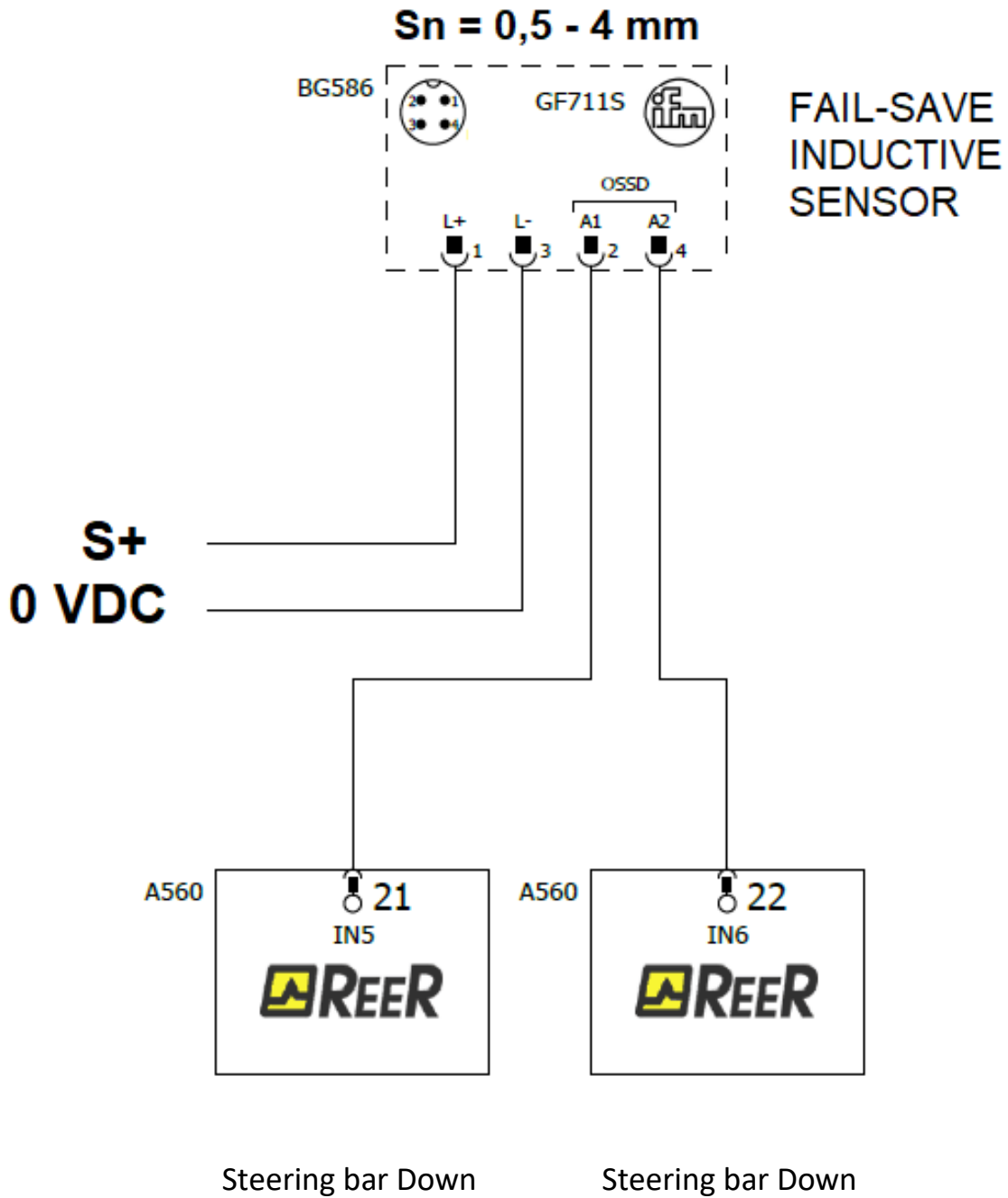

60.2.109 rev. 01 – S7 standard -

SIGNALS on the LASER SCANNER - S7 - 16V -



LEDS

OSSD LED	GREEN light: OSSD status ON	OSSD status ON The scanner does NOT detect object (thing or person)
	RED light: OSSD status OFF	The scanner DETECTS object (thing or person)

INTERLOCK LED	YELLOW light: interlock condition ACTIVE	It prevents the scanner from switching between OSSD = OFF or OBJECT DETECTION to the condition OSSD = ON or NOT OBJECT DETECTION
	Light OFF: interlock condition OFF	The scanner automatically switches from OSSD = OFF to OSSD = ON when it NO longer detects an object

WARNING 1 LED	Always OFF - Warning 1 zone function not active
WARNING 2 LED	Always OFF - Warning 2 zone function not active

 Norm. Tecn. 60.2.113 rev. 00	TECHNICAL DOCUMENTATION ROBOT S7– Stop&Go	September 2022	Rev.04
	ENGLISH	Pag. 97 / 124	

60.2.109 rev. 01 – S7 standard -

DISPLAY

Extract from the instrument manual for other indications, please refer to this manual

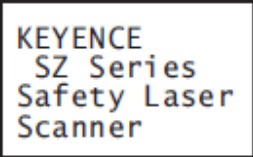
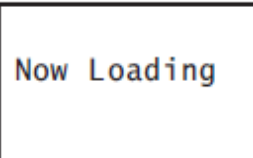
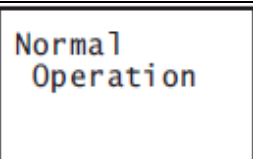
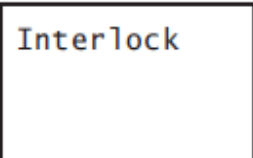
Absence of indications on the display		Possible connection problem or defective scanner
	Color display solid red	This indication must appear ONLY a few seconds after startup
	Color display flashing red	This indication must appear ONLY for about 20 seconds at start-up
	Color display solid green or solid red	<p>The SZ scanner is working normally.</p> <p>If the display is illuminated with light green the OSSD is in the state ON = OBSTACLE NOT DETECTED</p> <p>If the display is illuminated with red light the OSSD is in the state OFF = OBSTACLE DETECTED</p>
	Color display solid red or solid orange	<p>The scanner is in the condition of INTERLOCK</p> <p>(This prevents the scanner from switching between OSSD = OFF or OBJECT DETECTION to the condition OSSD = ON or NOT OBJECT DETECTION)</p>

60.2.109 rev. 01 – S7 standard -

DESCRIPTION of the SAFETY MODULES

MAIN UNIT (8 inputs / 4 single OSSDs) - A560 Mosaic M1S

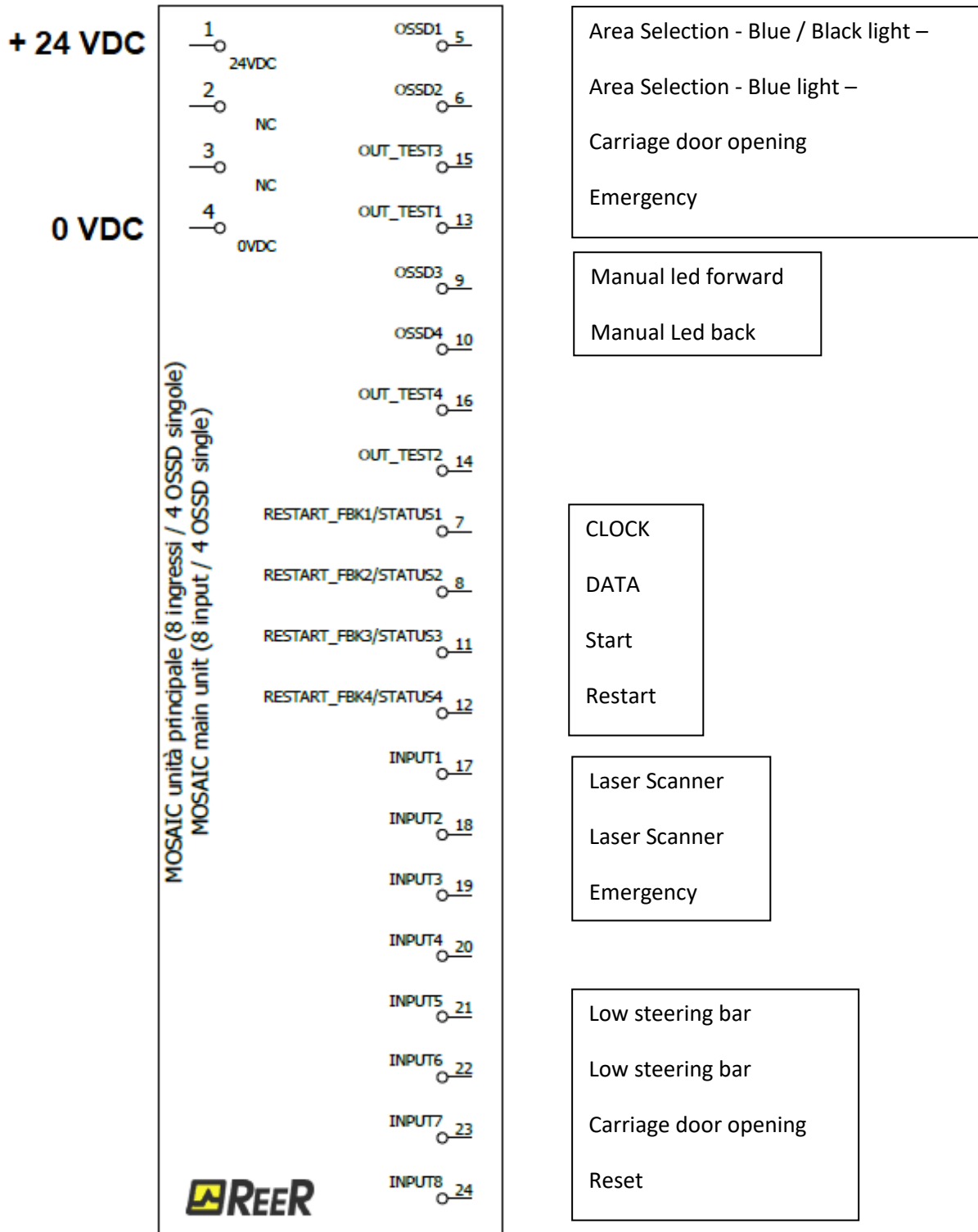

SIGNALING LEDs - normal operation and diagnostics - M1S

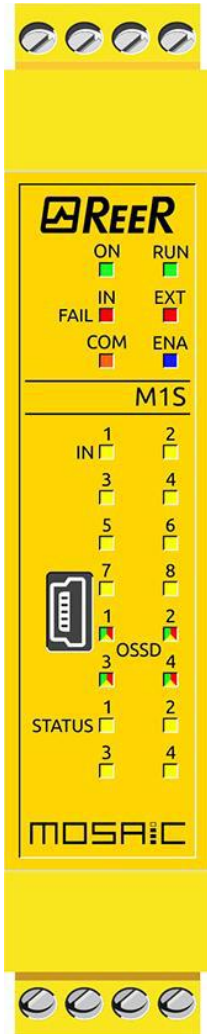

Normal operation		
MEANING	NORMAL OPERATION	EXTERNAL ANOMALY DETECTED
RUN GREEN	ON	ON
IN FAIL RED	OFF	OFF
EXT FAIL RED	OFF func. ok	ON wrong external connection detected
COM ORANGE	ON = M1S connected to PC OFF = otherwise	ON = M1S connected to PC OFF = otherwise
IN1-8 YELLOW	INPUT Condition	Flashing only the number of the INPUT with the wrong connection
ENA BLUE	ON	ON
OSSD1/4 RED GREEN YELLOW	RED with output OFF GREEN with output ON YELLOW waiting for RESTART Yellow Flashing with inconsistent feedback (if requested)	
STATUS1/4 YELLOW	OUTPUT Condition	

60.2.109 rev. 01 – S7 standard -

Diagnostics

MEANING	Internal fault	Error in OSSD Outputs	Comunica tion error with slave	Slave module error	MCM Error	Overload OSSD or load connected to 24 VDC	Short circuit or overload detected on exit status
RUN GREEN	OFF	OFF	OFF	OFF	OFF	ON	ON
IN FAIL RED	2 o 3 Flashes	4 Flashes	5 Flashes	ON	6 Flashes	OFF	OFF
EXT FAIL RED	OFF	OFF	OFF	OFF	OFF	ON	ON
COM ORANGE	OFF	OFF	OFF	OFF	6 Flashes	OFF	OFF
IN1-8 YELLOW	OFF	OFF	OFF	OFF	OFF	Input state	Input state
ENA BLUE	OFF	OFF	OFF	OFF	OFF	ON	ON
OSSD1/4 RED GREEN YELLOW	Red	4 RED flashes (only the LED corresponding to the output in fail)	OFF	OFF	OFF	Flashes RED (only the corresponding LED at the FAIL exit)	OUTPUT State
STATUS1/4 YELLOW	OFF	OFF	OFF	OFF	OFF	OUTPUT State	flashing
REMEDY	Replace the module	Check connections OSSD1/2 If it persists, replace the module	Restart the system If it persists, replace the module	Restart the system Check which module is in FAIL	Replace MCM	Check connections OSSD outputs	Check connections of the outputs status

I/O EXPANSION UNIT (8 inputs / 2 double OSSDs) - A564 Mosaic MI802

+ 24 VDC

0 VDC

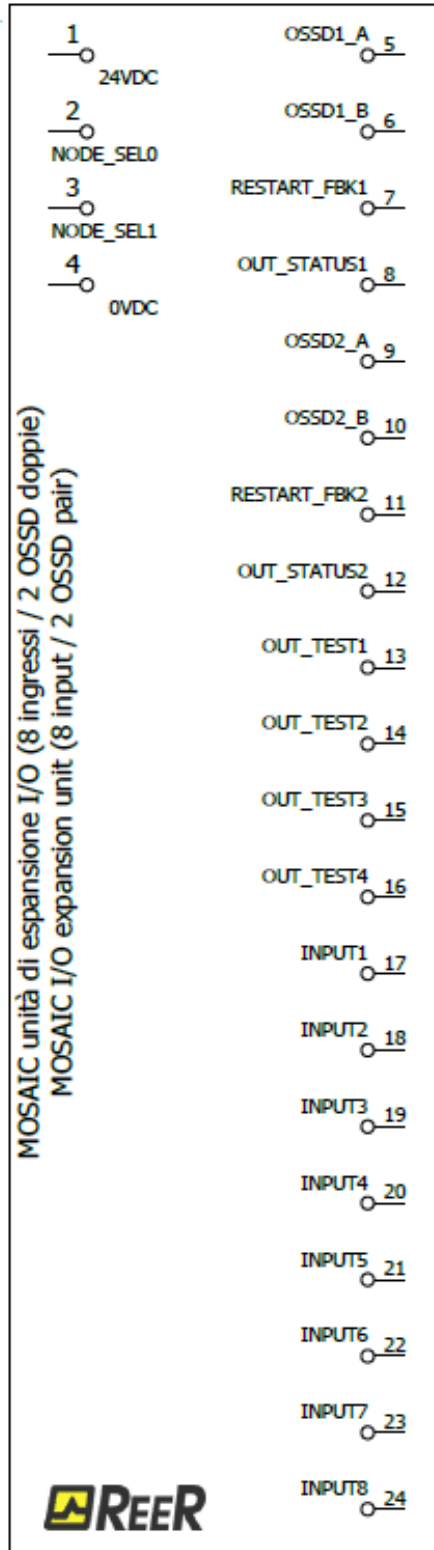

Manual forward led

Manual forward
Safety relay
Safety relay
Emergency feedback
Manual backward
Battery charger

Manual forward
Manual backward
Battery charger
Laser scanner Fault

Start
Automatic Cycle

SIGNALING LEDs - normal operation and diagnostics – MI802

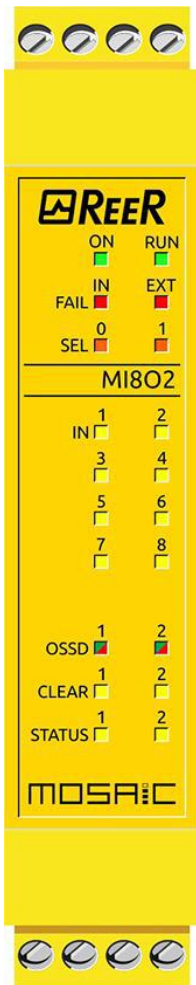

Normal operation		
MEANING	NORMAL OPERATION	
RUN GREEN	<p>OFF if the module is waiting for the first communication from the MASTER</p> <p>FLASHING if the configuration does not require INPUT or OUTPUT</p> <p>ON if the configuration requires INPUT or OUTPUT</p>	
IN FAIL RED	OFF	
EXT FAIL RED	OFF	ON wrong external connection detected
IN1-8 YELLOW	INPUT Condition	Flashing only the number of the INPUT with the wrong connection
SEL0/1 ORANGE	It reports the table of signals NODE_SEL0/1	
OSSD1/2 RED GREEN	<p>RED with output OFF</p> <p>GREEN with output ON</p>	
CLEAR1/2 YELLOW	<p>ON waiting for RESTART</p> <p>Flashing NO feedback</p>	
STATUS1/2 YELLOW	OUTPUT Condition	

Diagnostics

MEANING	Internal fault	Compatibility error	Error in OSSD Outputs	Comuni cation error with slave	Error on another slave or on M1	Another slave of the same type with the same address was detected	Node detection circuit error
RUN GREEN	OFF	OFF	OFF	OFF	OFF	OFF	OFF
IN FAIL RED	2 o 3 Flashes	5 Flashes	4 Flashes	5 Flashes	ON	5 Flashes	3 Flashes
EXT FAIL RED	OFF	OFF	OFF	OFF	OFF	5 Flashes	OFF
IN1-8 YELLOW	Reports the physical address of the module						3 Flashes
SEL0/1 ORANGE	OFF	5 Flashes	OFF	OFF	OFF	OFF	OFF
OSSD1/2 RED GREEN	Red	5 Flashes	4 RED flashes (only the LED correspondin g to the output in fail)	OFF	OFF	OFF	OFF
CLEAR1/2 YELLOW	OFF	5 Flashes	OFF	OFF	OFF	OFF	OFF
STATUS1/2 YELLOW	OFF	5 Flashes	OFF	OFF	OFF	OFF	OFF
REMEDY	Replace the module	Firmware version not compatible with M1, If it persists, replace the module	Check connections OSSD1/2 If it persists, replace the module	Restart the system If it persists, replace the module	Restart the system Check which module is in FAIL	Change address module (see paragraph NODE SEL of the instrument manual)	Replace the module

60.2.109 rev. 01 – S7 standard -

PROXIMITY SENSOR EXPANSION UNIT - A567 Mosaic MV0

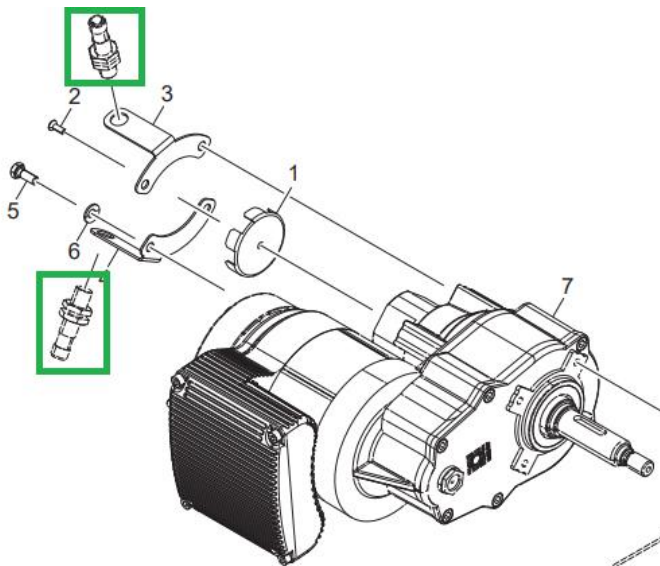
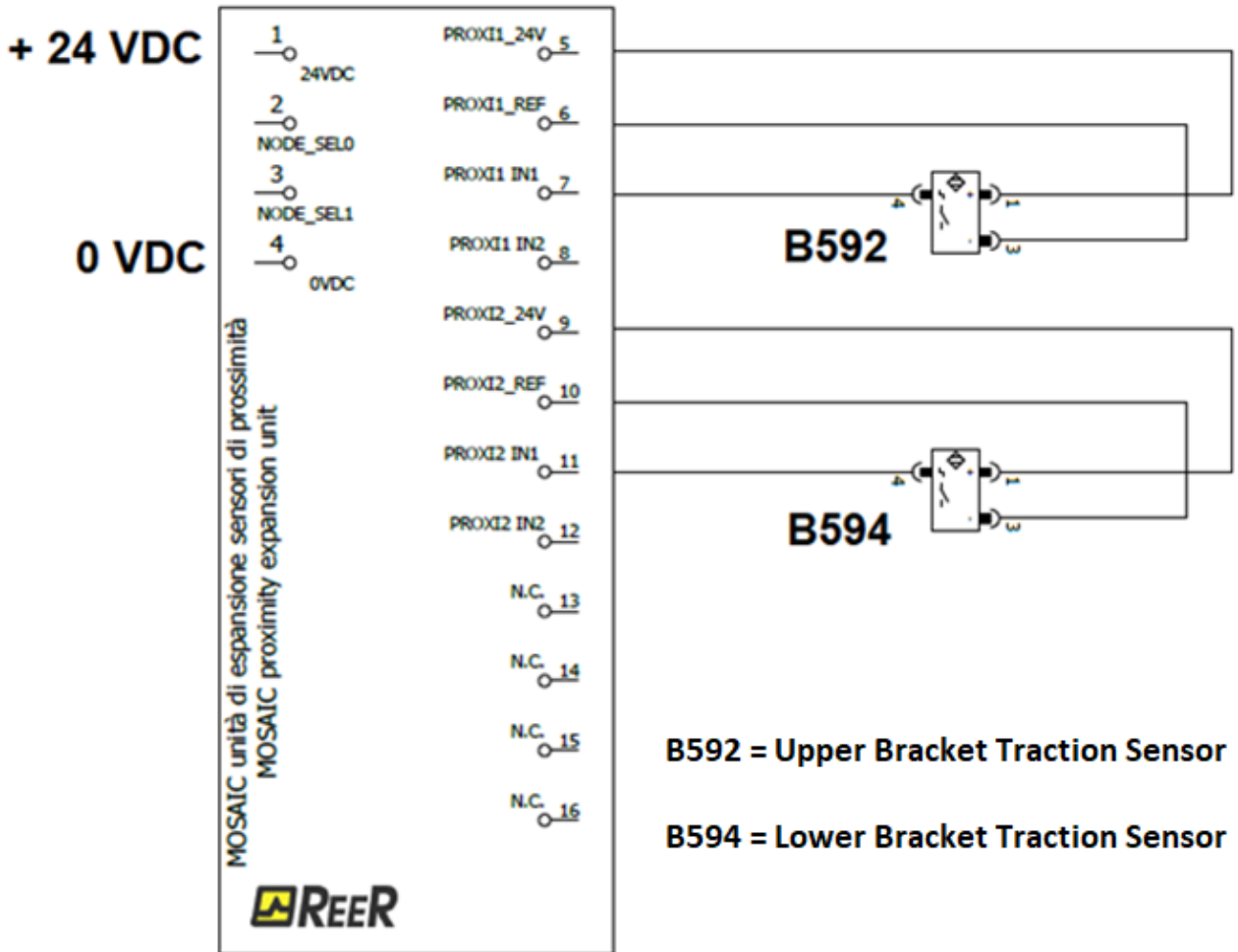

SIGNALING LEDs - normal operation and diagnostics – MVO



Normal operation	
MEANING	NORMAL OPERATION
ON GREEN	ON Powered module
RUN GREEN	OFF if the module is waiting for the first communication from the MASTER FLASHING if the configuration does not require INPUT or OUTPUT ON if the configuration requires INPUT or OUTPUT
IN FAIL RED	OFF Operation OK
EXT FAIL RED	OFF Operation OK
SEL0/1 ORANGE	It reports the table of signals NODE_SEL0/1
PROX YELLOW	ON Proximity connected and working
SH YELLOW	OFF Axis in speed range ON Axis in stand still FLASHING Axis out of speed range

60.2.109 rev. 01 – S7 standard -

Diagnostics

MEANING	Internal fault	Compatibility error	INTERNAL encoder error	INTERNAL proximity error	Node detection Circuit error	Another slave of the same type with the same address was detected	The encoder is not connected but is required by the configuration	Proximity not connected but required by configuration
RUN GREEN	OFF	OFF	OFF	OFF	OFF	OFF	OFF	OFF
IN FAIL RED	2 o 3 Flashes	5 Flashes	3 Flashes	3 Flashes	3 Flashes	5 Flashes	OFF	OFF
EXT FAIL RED	OFF	OFF	OFF	OFF	OFF	5 Flashes	Flashing	Flashing
SEL0/1 ORANGE	Reports the physical address of the module				3 Flashes	Reports the physical address of the module		
PROX YELLOW	OFF	5 Flashes	OFF	3 Flashes	OFF	OFF	OFF	Flashing
SH YELLOW	OFF	5 Flashes	OFF	OFF	OFF	OFF	OFF	OFF
REMEDY	Replace the module	Firmware version not compatible with M1, If it persists, replace the module	Replace the encoder Replace the module	Replace the proximity Replace the module	Internal fault, replace the module	Change address module (see paragraph NODE SEL of the instrument manual)	Verify correct encoder connection and its power supply Check input frequency in range	Verify correct proximity connection Check input frequency in range

 Norm. Tecn. 60.2.113 rev. 00	TECHNICAL DOCUMENTATION ROBOT S7– Stop&Go	September 2022	Rev.04
	ENGLISH	Pag. 107 / 124	

60.2.109 rev. 01 – S7 standard -

CHECK CORRECT POSITION OF THE BOTTOM CARRIAGE POSITION CAM

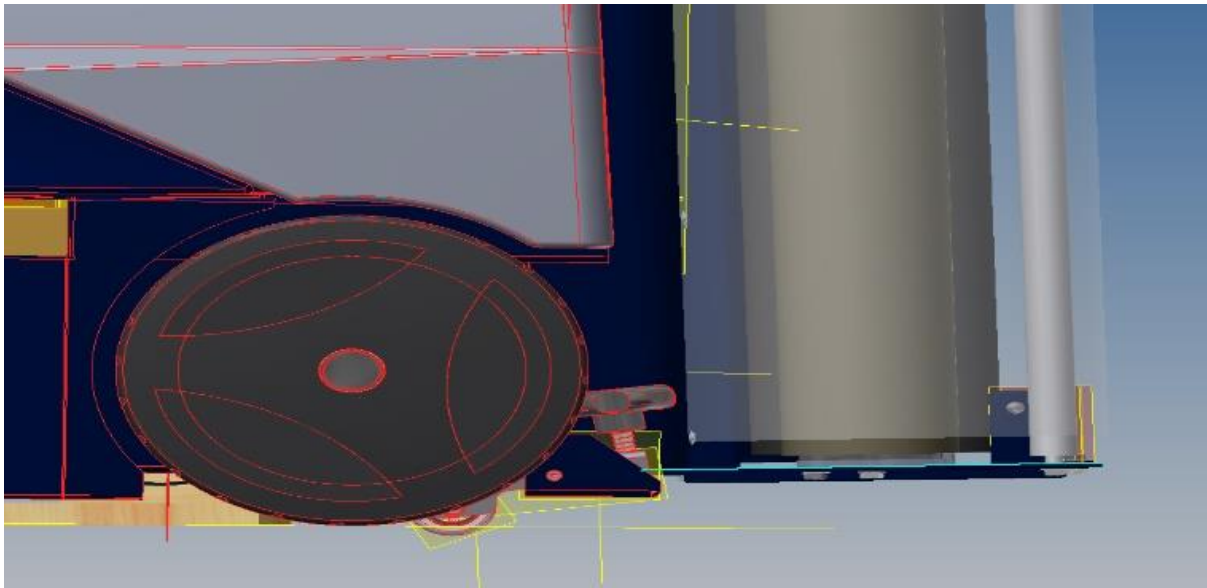

The bottom cam must be positioned so that the bottom plate of the carriage frame at the bottom stop is **15 mm from the ground**.

The measurement must be taken at the lowest point, therefore towards the mast.

 Norm. Tecn. 60.2.113 rev. 00	TECHNICAL DOCUMENTATION ROBOT S7– Stop&Go	September 2022	Rev.04
	ENGLISH	Pag. 108 / 124	

60.2.109 rev. 01 – S7 standard -

ALARM LIST

Emergency Button Alarm E1001



Emergency button pressed

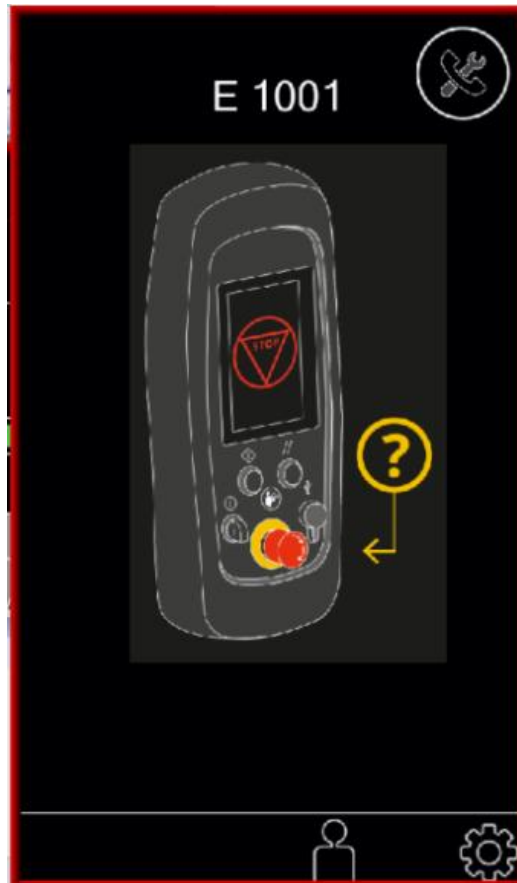

Emergency button pressed many times
during working cycle

60.2.109 rev. 01 – S7 standard -

Laser Scanner Alarm E1003



Cause	Solution
<p>The bumper has detected an obstacle in the working area YELLOW AREA in Automatic Cycle GREEN AREA in Manual Operation</p>	<p>Move the obstacle and press the "Reset" button.</p>

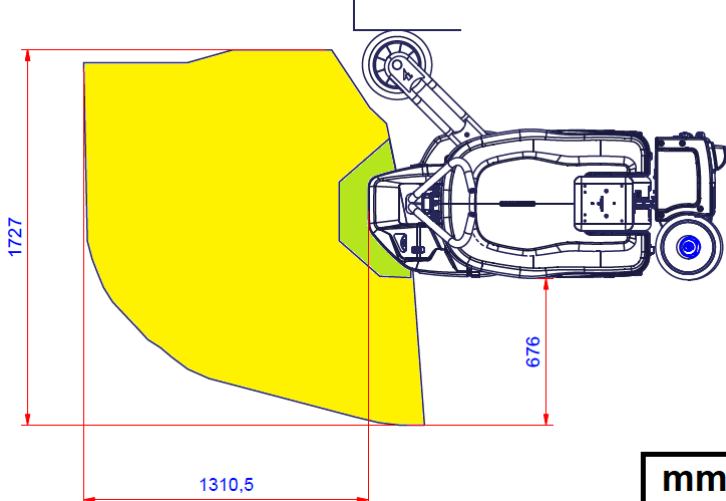

mm

60.2.109 rev. 01 – S7 standard -

Open Carriage Alarm E1010

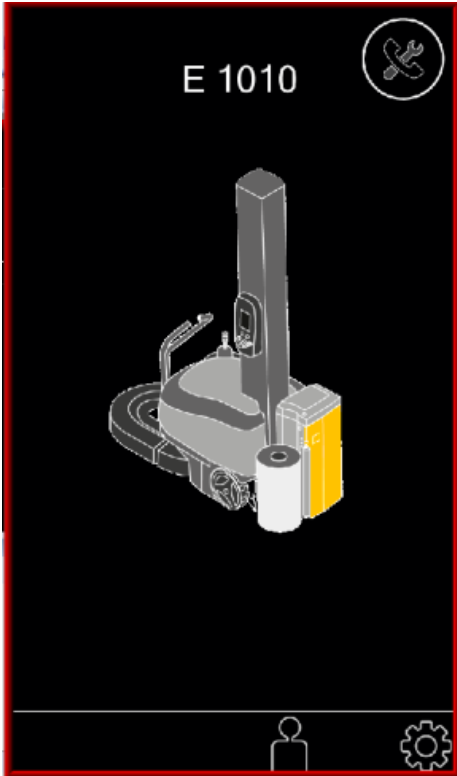

Steering Bar Alarm E1050

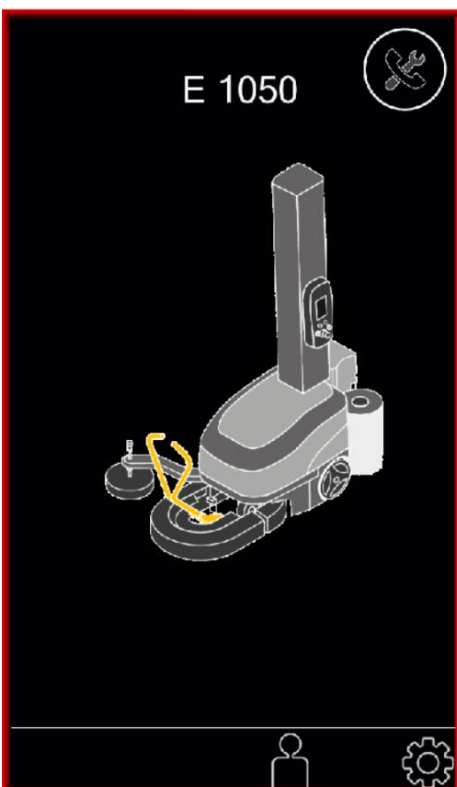

Cause	Solution
The cycle start button is pressed when the steering bar is in the low position. The steering bar is lowered during the automatic wrapping cycle.	Move the obstacle and press the "Reset" button.

60.2.109 rev. 01 – S7 standard -

Speed Alarm E1055



Cause	Solution
<p>A movement of the motorised wheel is detected without any manual control or wrapping cycle in progress. A speed higher than the threshold for operation is detected.</p>	<p>Check the wiring of the automatic machine signal from the automation PLC to the safety PLC by consulting the wiring diagram. Check the operation of the drive motor Press the “Reset” button.</p>

Laser Scanner Error E1060

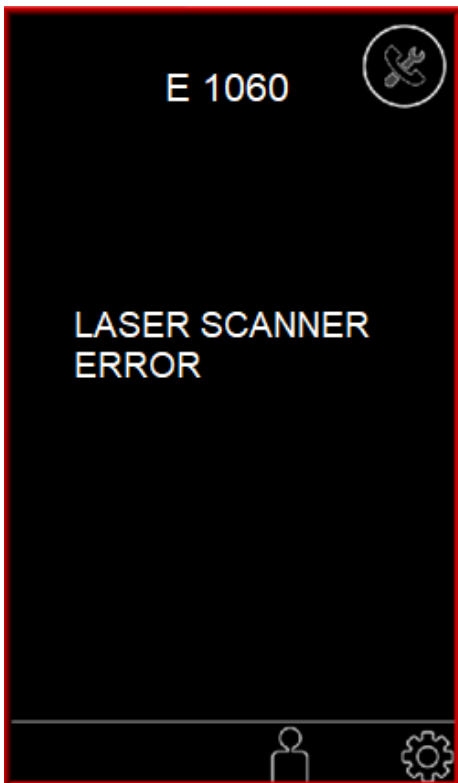

Cause	Solution
<p>Laser scanner malfunction.</p>	<p>Check the message on the laser scanner display and refer to the manufacturer's operating manual. To reset this alarm it may be necessary to switch the robot off and on again.</p>

60.2.109 rev. 01 – S7 standard -

Speed Sensors Error E1061

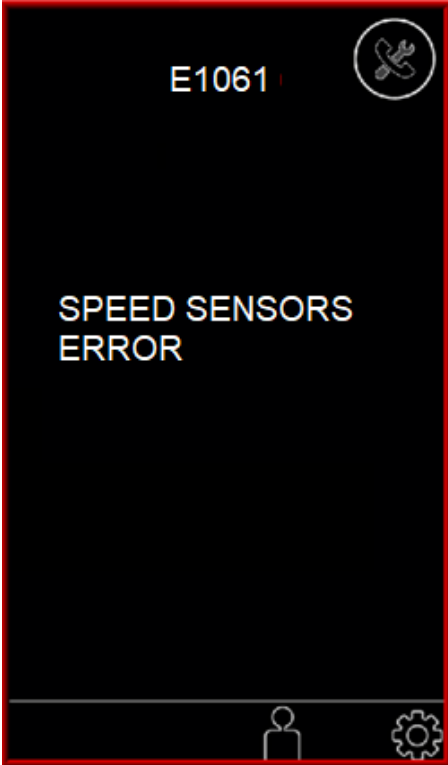

Cause	Solution
Speed detection system malfunction.	Check the condition of the phonic wheel and its sensors and check the wiring by consulting the wiring diagram. To reset the alarm, the robot must be switched off and on again.

PLC Signal Error E1062

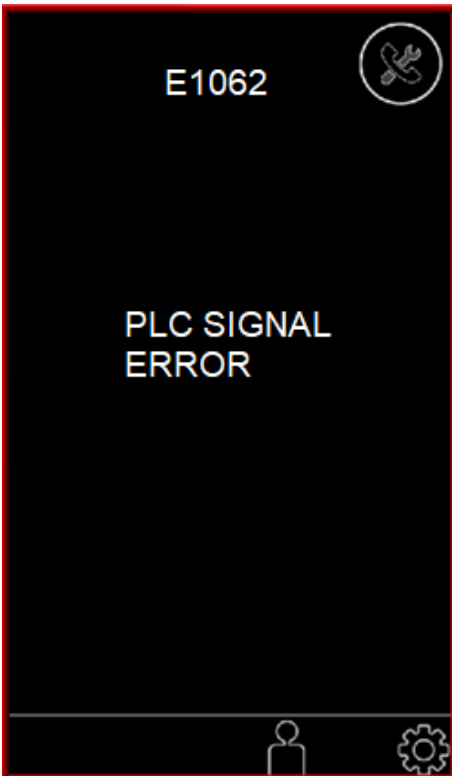

Cause	Solution
The automatic machine signal from the automation PLC to the safety PLC is shorted to +24V.	Check the wiring of the automatic machine signal from the automation PLC to the safety PLC by consulting the wiring diagram. Press the “Reset” button to clear the alarm.

60.2.109 rev. 01 – S7 standard -

Power contactor feedback error E1063



Cause	Solution
The display does not exit the reset page.	Check the status of the reset button and contactors and check their wiring by referring to the wiring diagram.

Battery in Charge Alarm E1090



Battery on charge (with INFO charging)

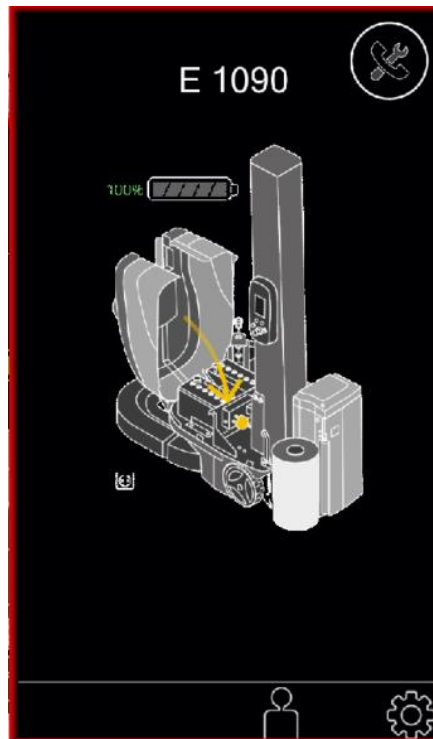

Charging completed successfully

 Norm. Tecn. 60.2.113 rev. 00	TECHNICAL DOCUMENTATION ROBOT S7– Stop&Go	September 2022	Rev.04
	ENGLISH	Pag. 114 / 124	

60.2.109 rev. 01 – S7 standard -

Motor Alarms E3x10



MOTOR ALARM

E3110 MOTOR1	2 : ENCODER
E3210 MOTOR2	5 : OVERTEMPERATURE
E3310 MOTOR3	7 : OVER CURRENT
E3410 MOTOR4	11: OVERCURRENT I2T
E3510 MOTOR5	15 : PHASE FAIL





E3110 Traction Motor	MOT 1
E3210 Carriage up/down Motor	MOT 2
E3310 Film Tension Motor	MOT 3
E3410 Film Prestretch Motor	MOT 4
E3510 Roping Motor e	MOT 5

Next to each motori is present
The motor alarm code:

- 2 - ENCODER
- 5 – OVERTEMPERATURE
- 6 – SHORT CIRCUIT
- 7 – OVERCURRENT
- 8 – PRECHARGE
- 9 – UNDERVOLTAGE
- 10 – OVERVOLTAGE
- 11 – OVERCURRENT I2T
- 12 - DISABLE
- 13 – KEY OFF
- 14 – EEPROM
- 15 – PHASE FAIL
- 16 – GENERIC
- 17 – WRONG PARAMETERS
- 18 – NO PARAMETERS

 <p>Norm. Tecn. 60.2.113 rev. 00</p>	<p>TECHNICAL DOCUMENTATION ROBOT S7– Stop&Go</p> <p>ENGLISH</p>	<p>September 2022</p>	<p>Rev.04</p>
<p>60.2.109 rev. 01 – S7 standard -</p>		<p>Pag. 115 / 124</p>	

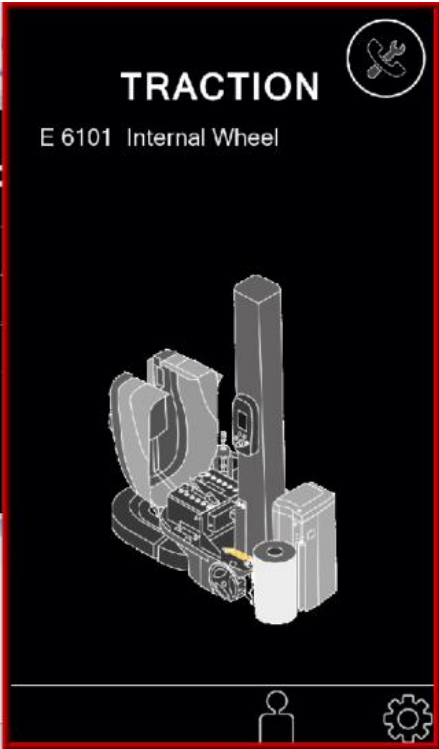
TRACTION Alarm E61xx



E6101 External wheel raised

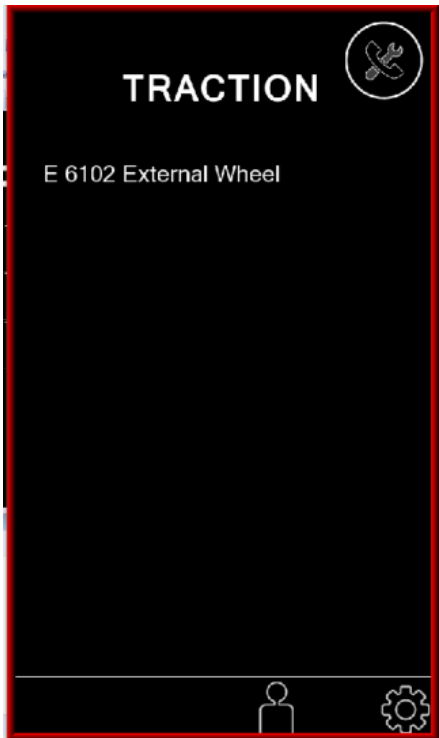

E6102 No signal traction motor encoder

 Norm. Tecn. 60.2.113 rev. 00	TECHNICAL DOCUMENTATION ROBOT S7– Stop&Go	September 2022	Rev.04
	ENGLISH	Pag. 116 / 124	

60.2.109 rev. 01 – S7 standard -

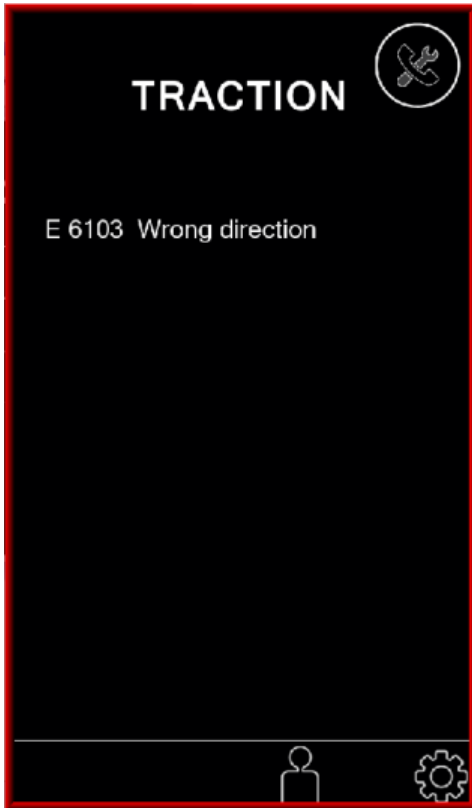

E6103 Inverted inner wheel

(steering system problem)

 Norm. Tecn. 60.2.113 rev. 00	TECHNICAL DOCUMENTATION ROBOT S7– Stop&Go	September 2022	Rev.04
	ENGLISH	Pag. 117 / 124	

60.2.109 rev. 01 – S7 standard -

LIFTING group (up/down carriage) Alarm E62xx

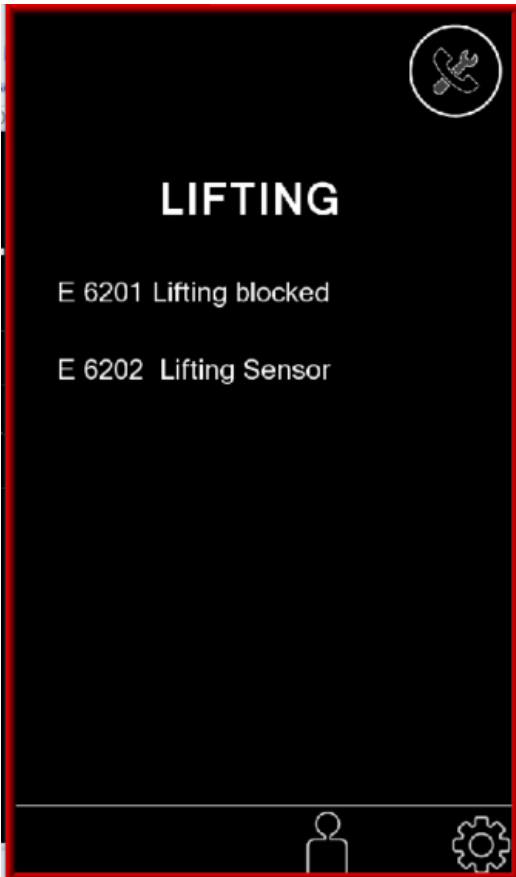

E6201 Lifting blocked Alarm

E6202 Lifting Sensors Alarm

(High and low limit switches active at the same time)

 Norm. Tecn. 60.2.113 rev. 00	TECHNICAL DOCUMENTATION ROBOT S7– Stop&Go	September 2022	Rev.04
	ENGLISH	Pag. 118 / 124	

60.2.109 rev. 01 – S7 standard -

FILM Alarms E63xx

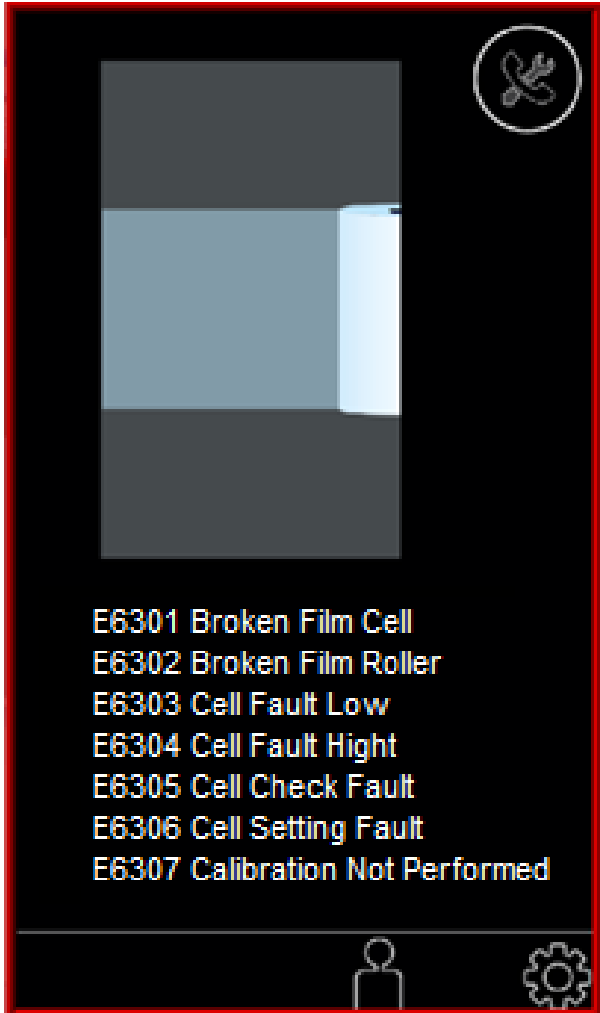

E6301 Film break Alarm detected by load cell sensor

E6302 Film break Alarm detected by film unwinding sensor

E6303 Load cell sensor fault, value too low

E6304 Load cell sensor fault, value too high

E6305 Load cell sensor fault, non-compliant no-load value

E6306 Load cell sensor setting fault

E6307 Load cell calibration not performed

 Norm. Tecn. 60.2.113 rev. 00	TECHNICAL DOCUMENTATION ROBOT S7– Stop&Go	September 2022	Rev.04
	ENGLISH	Pag. 119 / 124	

60.2.109 rev. 01 – S7 standard -

ROPING GROUP Alarms E64xx

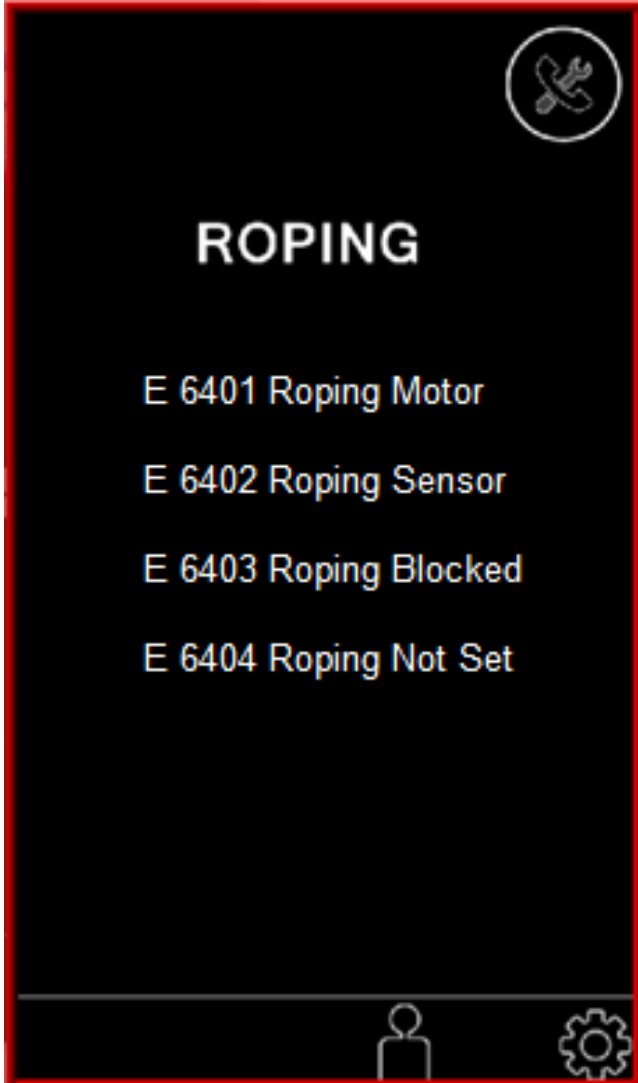

E6401 Roping motor Alarm

E6402 Roping sensors Alarm

(finecorsa alto e basso attivi contemporaneamente)

E6403 Roping Blocked Alarm

E6404 Roping setting not performed alarm

(perform calibration/setting of the roping device)

60.2.109 rev. 01 – S7 standard -

Alarm E68xx

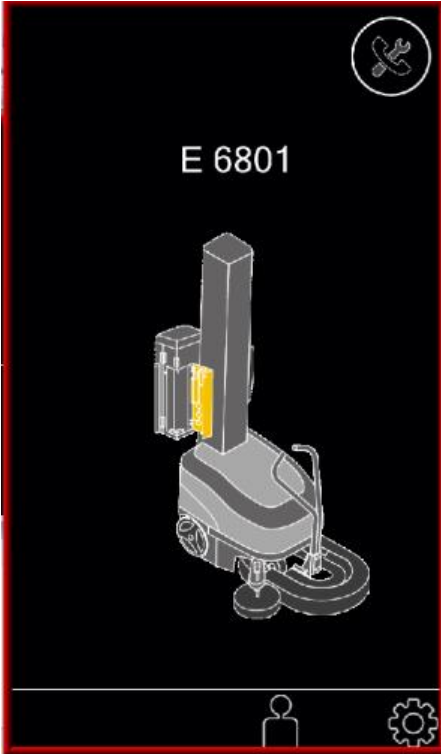

E6801 Carriage electrical panel open

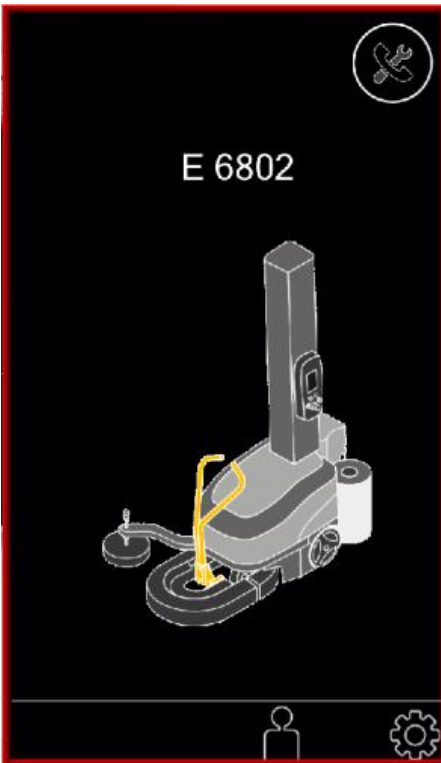

E6802 Forward steering wheel Alarm

 Norm. Tecn. 60.2.113 rev. 00	TECHNICAL DOCUMENTATION ROBOT S7– Stop&Go	September 2022	Rev.04
	ENGLISH	Pag. 121 / 124	

60.2.109 rev. 01 – S7 standard -

Communication alarms E80xx

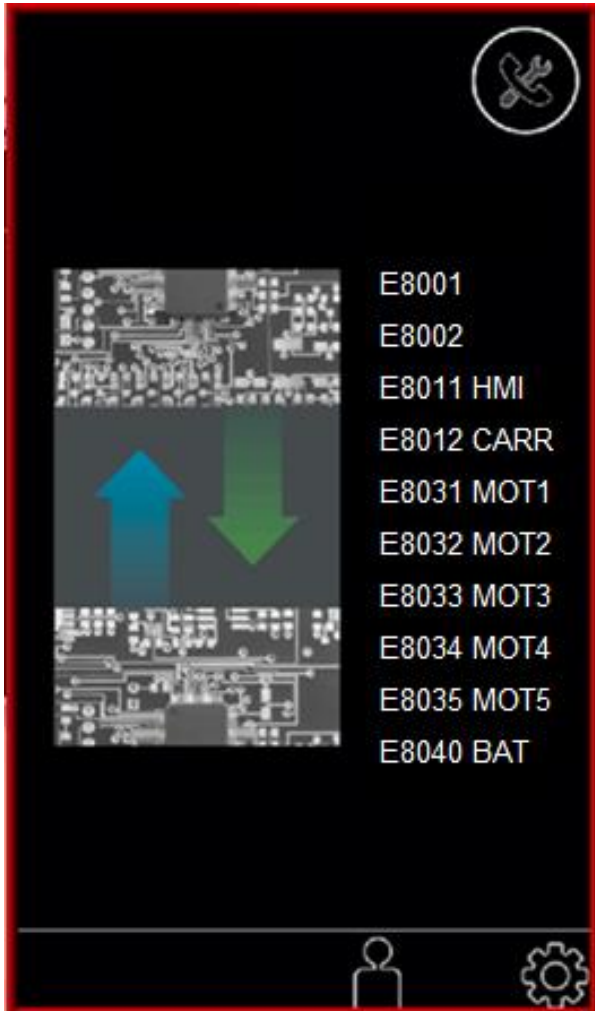

E8001 Communication Alarm with the Electrical Box PLC

E8002 Carriage PLC Can Communication Protocol Alarm

E8011 HMI Communication Alarm

E8012 Carriage PLC Communication Alarm

E8031 Traction motor Communication Alarm

E8032 Lifting motor Communication Alarm

E8033 Film unwinding motor Communication Alarm

E8034 Prestretch motor Communication Alarm

E8035 Roping motor Communication Alarm

E8040 Battery Communication Alarm

Alarms E9xxx

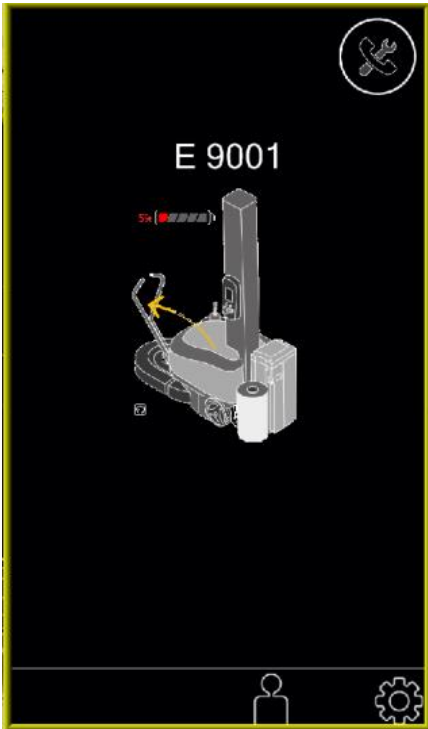

E9001 Low battery warning

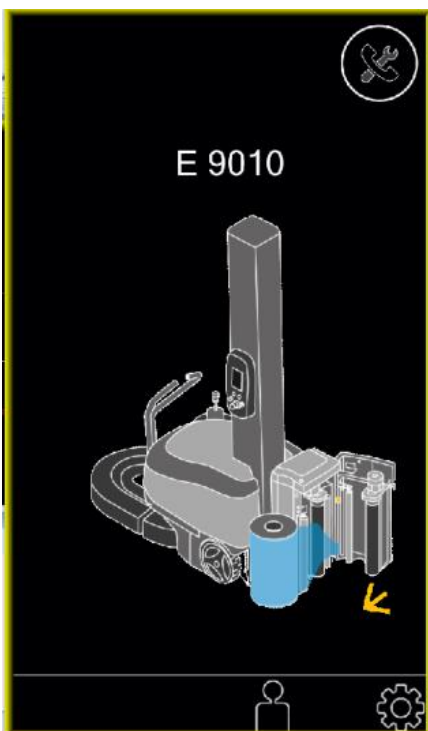

E9010 Change of the roping mode (from top or from bottom)

 Norm. Tecn. 60.2.113 rev. 00	TECHNICAL DOCUMENTATION ROBOT S7– Stop&Go	September 2022	Rev.04
	ENGLISH	Pag. 123 / 124	

60.2.109 rev. 01 – S7 standard -



E9020 Error in work recipes

 Norm. Tecn. 60.2.113 rev. 00	TECHNICAL DOCUMENTATION ROBOT S7– Stop&Go	September 2022	Rev.04
	ENGLISH	Pag. 124 / 124	

60.2.109 rev. 01 – S7 standard -

Improper battery use and charging E9030

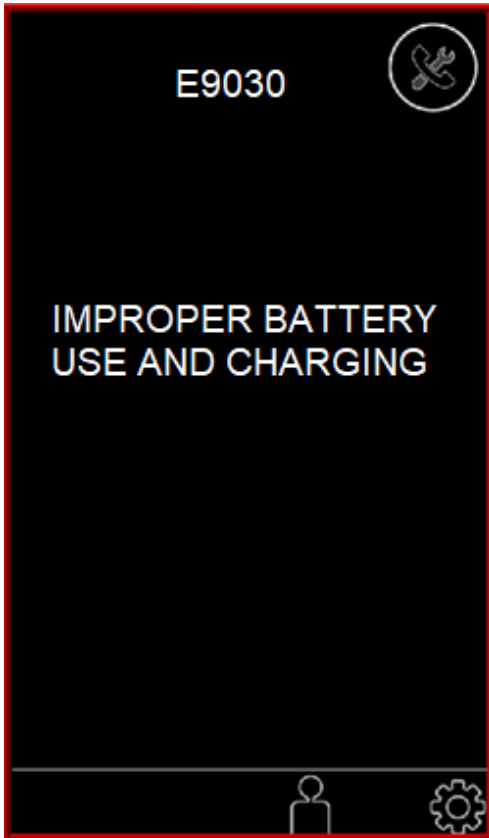

Causa	Rimedio
The battery is not sufficiently discharged before a charge or the charge is not completed correctly.	Use the battery properly