



Page left blank intentionally

## INDEX

<b>1. GENERAL INFORMATION .....</b>	<b>5</b>
1.1. PURPOSE OF THE MANUAL .....	5
1.2. MANUFACTURER AND MACHINE IDENTIFICATION .....	6
1.3. TERMS AND DEFINITIONS .....	7
1.3.1. PICTOGRAMS INDICATING DANGER .....	8
1.3.2. PICTOGRAMS INDICATING PROHIBITION .....	9
1.3.3. PICTOGRAMS INDICATING OBLIGATION .....	10
1.4. HOW TO REQUEST ASSISTANCE .....	11
1.5. ATTACHED DOCUMENTATION .....	11
1.6. HOW TO READ THE INSTRUCTIONS FOR USE .....	11
<b>2. SAFETY INFORMATION.....</b>	<b>12</b>
2.1. GENERAL SAFETY WARNINGS .....	12
2.2. SAFETY WARNINGS FOR HANDLING AND INSTALLATION .....	13
2.3. SAFETY WARNINGS FOR USE AND OPERATION .....	14
2.4. SAFETY WARNINGS RELATED TO MISUSE .....	15
2.4.1. REASONABLY FORESEEABLE MISUSE .....	15
2.4.2. EMPLOYER OBLIGATIONS .....	15
2.5. SAFETY WARNINGS ON RESIDUAL RISKS .....	16
2.6. SAFETY WARNINGS FOR ADJUSTMENTS AND MAINTENANCE .....	18
2.7. SAFETY WARNING FOR THE ELECTRICAL EQUIPMENT .....	19
2.8. INFORMATION AND SAFETY SIGNS .....	20
2.9. PERIMETER AREAS .....	22
2.10. MACHINE SAFE STOP .....	23
<b>3. TECHNICAL INFORMATION .....</b>	<b>24</b>
3.1. MACHINE GENERAL DESCRIPTION .....	24
3.1.1. MACHINE MODELS DESCRIPTION .....	27
3.2. DESCRIPTION OF OPERATING CYCLE AND WRAPPING MODES .....	28
3.2.1. DESCRIPTION OF THE OPERATION CYCLE .....	28
3.2.2. WRAPPING MODES .....	29
3.3. SAFETY DEVICE DESCRIPTION .....	30
3.4. DESCRIPTION OF ELECTRICAL DEVICES .....	32
3.5. DESCRIPTION OF ACCESSORIES ON REQUEST .....	33
3.6. TECHNICAL SPECIFICATIONS .....	34
3.6.1. MACHINE AND PALLET DIMENSIONS .....	34
3.6.2. TECHNICAL FEATURES .....	35
3.6.3. NORDELETTRICA NE284 BATTERY CHARGER .....	35
3.6.4. NORDELETTRICA NE328 BATTERY CHARGER FOR LITHIUM-ION BATTERIES .....	35
3.7. SPOOL TECHNICAL SPECIFICATIONS .....	36
3.7.1. SPOOL FEATURES .....	36
3.8. NOISE LEVEL .....	37
3.9. INSTALLATION ENVIRONMENT CHARACTERISTICS .....	37
<b>4. INFORMATION ON HANDLING AND INSTALLATION .....</b>	<b>38</b>
4.1. RECOMMENDATIONS FOR HANDLING AND LOADING .....	38
4.2. PACKING AND UNPACKING .....	38
4.3. TRANSPORT AND HANDLING .....	39
4.4. INSTALLATION OF DISASSEMBLED PARTS .....	40
4.4.1. INSTALLATION (WITH TILTED COLUMN) .....	40
4.4.2. INSTALLATION (WITH HORIZONTAL COLUMN) .....	41
4.4.3. INSTALLATION OF FEELER AND RUDDER .....	43
4.4.4. UPPER COVER INSTALLATION .....	45
<b>5. INFORMATION ON ADJUSTMENTS .....</b>	<b>46</b>
5.1. RECOMMENDATIONS FOR ADJUSTMENTS .....	46
5.2. "FILM STRETCH" ADJUSTMENT .....	46
5.2.1. "FRD for mesh" TYPE REEL CARRIAGES .....	46

5.2.2. "P3GS" REEL CARRIAGES FOR CHANGING PRE-STRETCH RATIOS .....	47
5.3. SPOOL CARRIAGE LIFTING CHAIN ADJUSTMENT .....	48
5.4. STEERING WHEEL RETURN SPEED ADJUSTMENT .....	49
5.5. ADJUSTING THE HEIGHT OF THE FEELER WHEEL .....	49
5.6. FEELER THRUST ADJUSTMENT .....	50
<b>6. INFORMATION ABOUT THE USE .....</b>	<b>51</b>
6.1. RECOMMENDATIONS FOR OPERATION AND USE .....	51
6.2. DESCRIPTION OF THE CONTROLS .....	52
6.3. DESCRIPTION OF USER INTERFACE .....	53
6.3.1. NUMERICAL AND ALPHANUMERICAL KEYBOARD .....	56
6.3.2. PROGRAMMING WINDOW .....	57
6.3.3. USING THE PANEL .....	59
6.4. "HOME" PAGE .....	60
6.4.1. "HOME STANDARD CONTROL" PAGE .....	60
6.4.2. "HOME MULTILEVEL CONTROL" PAGE .....	62
6.5. "MANUAL HANDLING" PAGE .....	63
6.6. "RECIPES" PAGE .....	64
6.6.1. "COPY RECIPE" PAGE .....	65
6.6.2. "COPY LEVEL" PAGE .....	65
6.6.3. "DATA TRANSFER" PAGE .....	66
6.7. "WRAPPING CYCLE" PAGE .....	67
6.8. "GENERAL PARAMETERS" PAGE .....	69
6.9. "PRODUCTION COUNTERS (PALLETES)" PAGE .....	70
6.10. "HMI SETTINGS" PAGE .....	71
6.11. "PASSWORD CHANGE" SCREEN .....	72
6.12. "ENTER PASSWORD" SCREEN (USER LOGIN) .....	73
6.13. "SERVICE" SCREEN .....	74
6.14. NEW RECIPE PROGRAMMING .....	74
6.15. WRAPPING START AND STOP .....	75
6.16. FILM SPOOL FEEDING .....	77
6.17. FILM REEL FEEDING (APPLICABLE TO "P3GS" AND "PVS" CARRIAGES ONLY) .....	78
6.18. BATTERY CHARGER MODE .....	79
<b>7. MAINTENANCE INFORMATION .....</b>	<b>82</b>
7.1. RECOMMENDATIONS FOR MAINTENANCE .....	82
7.2. PERIODICAL MAINTENANCE INTERVALS .....	82
7.3. LUBRICATION POINT DIAGRAM .....	83
7.4. LUBRICANT TABLE .....	84
<b>8. FAULT INFORMATION .....</b>	<b>85</b>
8.1. ALARM MESSAGES .....	85
<b>9. REPLACEMENT INFORMATION .....</b>	<b>88</b>
9.1. RECOMMENDATIONS FOR REPLACING MACHINE PARTS .....	88
9.2. BATTERY REPLACEMENT .....	89
9.3. RECOMMENDED SPARE PARTS LIST .....	90
9.4. MACHINE DECOMMISSIONING AND SCRAPPING .....	90
9.4.1. MACHINE DECOMMISSIONING .....	90
9.4.2. MACHINE SCRAPPING .....	90
<b>10. ANNEXES .....</b>	<b>91</b>
10.1. WARRANTY CONDITIONS .....	91

## 1. GENERAL INFORMATION

### 1.1. PURPOSE OF THE MANUAL

- The manual is an integral part of the machine and is aimed at providing the operator with the “Instructions for use” in order to prevent and minimise the risks that arise from human-machine interaction.

**The information has been written by the Manufacturer in Italian (the original language) in full compliance with the professional writing principles and the regulations in force.**

**The communication principles were chosen according to the target readers in order to ease the reading and understanding of the information.**

**The information may be translated into other languages to satisfy the legal and/or market requirements.**

**The manuals must be translated directly from the original instructions, without modifications.**

**Each translation (including that provided by the purchasing agent or by the company that introduces the machine into the country in question) must specify the message “Translation of the original instructions”.**

- Refer to the table of contents in order to easily identify the subjects of interest.
- Some information may not correspond completely to the actual configuration of the machine delivered.
- Any additional information does not affect the readability of the text and the safety level.
- The Manufacturer reserves the right to modify the contents of the manual without prior notice provided that the safety level is not altered.
- Every notification by the recipients can be an important contribution to the improvement of after-sales services that the manufacturer intends to offer to its customers.
- The symbols described below are used to highlight important information or specifications.



#### **Danger - warning**

The symbol indicates critically dangerous situations that if neglected can result in serious personal safety and health hazards.



#### **Caution - warning**

The symbol indicates that appropriate action must be taken to avoid causing damage or malfunction to the machine.



#### **Important**

The symbol indicates particularly important technical and operating information that should not be neglected.

## 1.2. MANUFACTURER AND MACHINE IDENTIFICATION

The illustrated identification plate is applied directly to the machine. It contains references and indispensable operating safety indications.

1. Machine model.
2. Machine serial number.
3. Year of manufacture.
4. Power supply voltage.
5. Power supply frequency.
6. Power supply phases.
7. Absorbed electric current.
8. Installed power.
9. Air consumption.
10. Air supply max. pressure.
11. Machine weight.
12. Manufacturer's identification.
13. Name.

12



**ROBOPAC S.p.a**  
 Via Fabrizio da Montebello, 81  
 47892 Repubblica di San Marino  
 Phone (+378) 0549 910511  
 Fax (+378) 0549 908549



DENOMINAZIONE DENOMINATION	13		
MODELLO MODEL		1	
MATRICOLA SERIAL NUMBER	2		
DATA DATE OF MAN.		3	
ALIMENTAZIONE SUPPLY VOL.	4		V
FREQUENZA FREQUENCY		5	Hz
N.FASI PHASE	6		
ASSORBIMENTO ABSORPTION		7	A
POTENZA TOT. TOTAL POWER	8		kw
CONSUMO ARIA AIR CONSUMPTION		9	l/min
PRESSIONE MAX MAX. PRESSURE	10		bar
PESO WEIGHT		11	kg

### 1.3. TERMS AND DEFINITIONS

Some recurring terms found within the manual are described in order to complete their meaning.



**Maintenance:**

The set of operations required to maintain the machine efficient and in good working order. Normally some operations are scheduled by the manufacturer, who defines the necessary skills and methods of intervention. Some unscheduled operations must be performed after consulting the manufacturer.



**Operator:**

A person chosen and authorised among those who have the requirements, skills and information necessary for installation, use and ordinary maintenance of the machine.



**Maintenance technician:**

Technician chosen and authorised among those who have the requirements to perform routine and extraordinary maintenance on the machine. Therefore, the technician must have accurate information and competences with particular skills in the field of intervention.



**Format changeover:**

Set of operations to carry out on the machine before starting to work with characteristics other than the previous ones.



**Training:**

Training process aimed at transferring to the new operator the knowledge, skills and behaviours required to operate the machine autonomously, properly and safely.



**Installer:**

Technician chosen and authorised by the manufacturer or by its representative, among those with the requirements to install and test the machine or the relevant system.



**Assistant:**

Employee assigned to assist the production processes of the machine or system in question.



**Production manager:**

Qualified technician, with experience and competence in the field of machinery for the reference sector. Depending on the production requirements, the production manager can operate the machine directly, or select the operator to be assigned to the task.

### 1.3.1. PICTOGRAMS INDICATING DANGER

The following table summarises the safety-related pictograms which indicate **DANGER**.



**ATTENTION - GENERIC DANGER**

This draws the attention of the personnel concerned to the risk of physical injuries caused by the operation described if it is not carried out in compliance with safety regulations.



**ATTENTION - DANGER DUE TO CONTACT WITH LIVE PARTS**

This indicates to the personnel concerned that the described operation poses, if not carried out in compliance with safety regulations, a risk of electric shock.



**ATTENTION - DANGER DUE TO FLAMMABLE MATERIAL**



**ATTENTION - DANGER DUE TO MOVING PARTS**



**ATTENTION- DANGER DUE TO HIGH TEMPERATURES**



**ATTENTION - DANGER DUE TO SUSPENDED LOADS**



**ATTENTION - DANGER DUE TO CONTACT WITH OVERHEAD OBSTACLES**



**ATTENTION - TRIPPING OR FALLING DANGER**



**ATTENTION - TANGLING DANGER**

It signals to the concerned personnel that the device bearing this pictogram features parts where there is the risk getting tangled when accessed.



**ATTENTION - HAND CRUSHING DANGER**



**ATTENTION - SHEARING DANGER**



**ATTENTION - CUTTING DANGER**

It signals to the concerned personnel that the device on which the pictogram is located has sharp parts that may injure their hands.



**ATTENTION - DANGER DUE TO CARRIAGE MOVEMENT**



**ATTENTION - EXPLOSION DANGER**

### 1.3.2. PICTOGRAMS INDICATING PROHIBITION

The following table summarises the safety-related pictograms indicating **PROHIBITION**.



**GENERIC PROHIBITION**



**NO SMOKING**

Smoking is not allowed in the area where this sign is located.



**NO NAKED FLAMES**

This symbol prohibits the use of naked flames near the machine or parts of it to prevent a fire hazard.



**NO PEDESTRIANS**

Pedestrians are not allowed to pass through the area where this signal is located.



**DO NOT EXTINGUISH WITH WATER**

Any fire that may occur near the machine or parts of it must NOT be extinguished with jets of water.



**DO NOT INSERT YOUR HANDS**



**DO NOT PUSH**



**DO NOT SEAT DOWN**



**DO NOT CLIMB ONTO THE SURFACE**



**DO NOT REMOVE THE OPERATOR GUARDS**

### 1.3.3. PICTOGRAMS INDICATING OBLIGATION

The following table summarises the safety-related pictograms indicating **OBLIGATION**.



#### **GENERIC OBLIGATION**

The presence of the symbol next to the description indicates the obligation to carry out the operation/manoeuvre as described and in compliance with current safety regulations, in order to avoid risks and/or injuries.



#### **OBLIGATION TO REFER TO THE OPERATOR'S MANUAL**

Obligation, before carrying out any operation on the machine, to read the Instruction Manual supplied with the machine.



#### **OBLIGATION TO USE LUBRICANTS RECOMMENDED**

Obligation, before changing the oil or the lubricants, to read the Instruction Manual supplied with the machine.



#### **OBLIGATION TO WEAR PROTECTIVE GLOVES**

The presence of the symbol next to the description requires the use of protective gloves by the operator, since the risk of injury is implicit.



#### **OBLIGATION TO WEAR PROTECTIVE GOGGLES**

The presence of the symbol next to the description requires the use of safety goggles by the operator, since the risk of injury is implicit.



#### **OBLIGATION TO WEAR A PROTECTIVE HELMET**

The presence of the symbol next to the description requires the use of a protective helmet by the operator since the risk of injury is implicit.



#### **OBLIGATION TO WEAR A PROTECTIVE MASK**

The presence of the symbol next to the description requires the use of a respiratory protective mask by the operator, since the risk of injury is implicit.



#### **OBLIGATION TO WEAR SAFETY SHOES**

The presence of the symbol next to the description requires the use of protective shoes by the operator, since the risk of injury is implicit.



#### **OBLIGATION TO WEAR PROTECTIVE CLOTHING**

The presence of the symbol next to the description requires the use of a protective overall by the operator, since the risk of injury is implicit.



#### **OBLIGATION TO WEAR EARMUFFS FOR PROTECTION AGAINST NOISE**

The presence of the symbol next to the description requires the use of earmuffs by the operator as the risk of injury is implicit.

## 1.4. HOW TO REQUEST ASSISTANCE

**Robopac** distribution network is at your disposal for any problem regarding technical assistance, spare parts and any new requirement you might need for your business.

For every technical service request regarding the machine, please indicate the data found on the identification plate, the approximate hours of use and the type of fault detected.

Please refer to one of the authorised service centres or directly to the address indicated for any need.

ROBOPAC S.p.A  
 VIA FABRIZIO DA MONTEBELLO, 81  
 47892 GUALDICCIOLO REPUBLIC OF S. MARINO (RSM)  
 Tel. 0549 (international ++378) 910511  
 Fax 0549/908549 - 905946  
<http://www.robopac.com>

## 1.5. ATTACHED DOCUMENTATION

The machine is provided with the documentation listed below, unless otherwise agreed.

- EC Declaration of Conformity;
- Warranty conditions;
- Battery charger user manual;
- Battery documentation;
- Manuals of installed commercial devices (if necessary for machine use);
- USB pendrive containing the information listed below:
  - Use and maintenance manual translated into various languages;
  - Spare parts catalogue;
  - Machine programming software;
  - Wiring Diagrams.

## 1.6. HOW TO READ THE INSTRUCTIONS FOR USE

The manual is divided into chapters, each of which describes a specific category of information.



### Important

**Every operator who interacts with the machine, in addition to reading all the documentation, must read and learn the information that falls within his/her operational competence.**

Refer to the abbreviation that precedes the title of the chapters in the index, to search for topics to consult.

These instructions are the result of an automatic system that assembles text and illustrations, so it is possible that when changing pages, there might be interruptions in the flow of text and tables.



### Important

**Keep this manual for the entire duration of the machine useful life in a well known and easy to access place, available for reference any time the need should arise.**

## 2. SAFETY INFORMATION

### 2.1. GENERAL SAFETY WARNINGS



**Caution - warning**

Carefully read the “Instructions for use” specified in the manual and those applied directly to the machine.

It is important to dedicate a little time to read the “Instructions for use” in order to minimise the risks and avoid unpleasant accidents.

Before performing any operation, the operator must make sure that he/she has understood the “instructions for use”.



**Danger - warning**

Pay attention to the safety warnings, do not misuse the machine and assess the possible residual risks.

Caution is essential.

Safety is also in the hands of those who interface with the machine throughout its life span.



**Important**

**Sometimes, accidents can be caused by a “careless” use of the machine by the operator.**

**Usually it is too late to remember what should have been done when the accident has already happened.**



**Caution - warning**

Preserve the readability of the information signs and observe the indications given.

The information signs may have different shapes and colours, indicating hazards, obligations, prohibitions and indications.

Tampering with the safety devices and the removal of the same may create risks (even severe) for the operators.

The personnel authorised to carry out any operation with the machine must have acknowledged experiences in the specific field.



**Important**

**The manufacturer is not responsible for any damage to the packaged product occurred during wrapping, stabilisation and following operations.**



**Important**

**Non-compliance with the instructions given may cause risks to the safety and health of people, as well as economic damages.**

## 2.2. SAFETY WARNINGS FOR HANDLING AND INSTALLATION



### Danger - warning

The personnel authorised to handle the machine (load and unload) must possess the necessary technical and professional knowledge and skills.

Handle (load and unload) the machine according to the instructions affixed directly to the machine, to the package and in the user manual.

During handling use one or more assistants, if required. This may pose unexpected risks.

In order to minimise the risks related to assistants' involvement, you must inform them in advance on the type of work to be carried out and the behaviour to adopt.

Handling must be carried out with the aid of specific means (crane, forklift truck etc.) by qualified personnel capable of observing the safety requirements.

When using the lifting means, insert and/or fasten the devices (hooks, forks etc.) only into the points provided on the package and/or on the machine.

Transport the machine with suitable means of adequate capacity.

The minimum and maximum temperature (during transport and/or storage) must fall within the range allowed in order to prevent damaging the electrical components (see paragraph "technical features").

Install the machine only in spaces with no explosion and/or fire risks.

Avoid spaces exposed to atmospheric and corrosive agents.

Assess, prior to installation, if it is necessary to implement a "safety plan" in order to protect the safety of the personnel involved.

Provide proper safety conditions when operating in high areas that are dangerous or hard to access.

Install the machine according to the minimum perimeter spaces indicated by the Manufacturer and the surrounding working activities.

Prepare a machine installation project if the machine is to interact (directly or indirectly) with another machine or with a production line.

The project must take into account all operating conditions, in order to comply with all laws in force on matter of safety in the workplace.

Check that the installation space is properly ventilated in order to avoid unhealthy air concentration for the operators.

Implement the most suitable solutions to minimise noise emission levels and acoustic pollution.

Carry out the electrical connections in accordance with the best practice and in full compliance with the instructions provided by the Manufacturer and the specific regulations in force.



### Important

**The electrical connections must be carried out exclusively by operators with acquired and acknowledged skills in the field of intervention.**

The installer must test the machine and check, through a general test, that the machine can be commissioned without any risk for the operator.

Dispose of all the packaging components in compliance with the standards in force in the Country of installation.

**Non-compliance with the instructions given may cause risks to the safety and health of people, as well as economic damages.**



### Danger - warning

Read the battery manual for possible hazards and/or warnings regarding the storage of the battery.

## 2.3. SAFETY WARNINGS FOR USE AND OPERATION



### **Danger - warning**

The operator must be trained and possess the adequate skills required to carry out the specific tasks and must be fit to use the machine safely.

When using the machine for the first time, the operator must read the manual and identify the control functions and simulate some operations, especially machine start and stop.

The machine has been designed and manufactured to meet all the operating conditions indicated by the Manufacturer.



### **Caution - warning**

Use the machine only with the original safety devices installed by the Manufacturer.

Do not tamper with, disable, remove or bypass the safety devices installed on the machine.



### **Danger - warning**

Do not modify the constructive and functional characteristics of the machine in any way.

Do not use the machine with the safety devices not properly installed and efficient.

Always wear the Personal Protective Equipment indicated in the "Instructions for use", **in particular safety shoes**, and that provided for by the laws in force on matter of safety in the workplace.

Always keep the perimeter areas in suitable conditions and free from obstacles in order to minimise the risks for the operator, especially near the control station.

The machine must be used **by one operator only**, that must be appointed and authorised by the employer.

The involvement of one or more assistants when performing some operations or maintenance (ordinary) interventions may pose unpredictable risks.

In order to minimise the risks related to assistants' involvement, you must inform them in advance on the type of work to be carried out and the behaviour to adopt.

Make sure that no unauthorised persons are within the machine operating area during its production activity and during maintenance.



### **Important**

**Non-compliance with the instructions given may cause risks to the safety and health of people, as well as economic damages.**



### **Danger - warning**

Do not use the machine to wrap potentially explosive packages or products.

## 2.4. SAFETY WARNINGS RELATED TO MISUSE

### 2.4.1. REASONABLY FORESEEABLE MISUSE

- The reasonably foreseeable misuse is: “the use of the machine in a way other than that indicated in the manual, that may stem from the easily predictable human behaviour”.
- **The machine must be used to wrap and stabilise objects placed on pallets. Objects must have been positioned beforehand so that:**
  1. there are no protruding parts out of the pallet;
  2. the stability of the objects is such that during film wrapping they do not move.

**The packages containing the products must be closed and sealed in order for the product contained not to come out.**

- Do not palletise or wrap products housed in irregularly shaped packages (boxes, liquid containers, etc.) or packages that do not guarantee their stability.
- Do not use the machine on slippery surfaces or surfaces that could be slippery (e.g.: wet, oily or greased).
- The machine should only be used for the uses intended by the Manufacturer.
- Do not allow the machine to be used by operators who are not properly trained and authorised.
- Packages containing liquid or insubstantial products must ensure that they do not leak out.
- Do not wrap bulk products of irregular shape and improperly collected.
- Do not use the machine to wrap and stabilise living beings (animals and persons).
- Do not use the machine with wrapping material other than that provided by the Manufacturer.
- Do not use the machine as a lifting device or as a work surface (e.g. workbench).
- Do not climb on the machine, as you may fall off and tip it over.
- Do not stretch or pre-stretch the film excessively and do not wrap the product with too many wrappings in order to prevent damaging the packages and the products contained in them.
- Do not use or let the machine be used for purposes or in ways other than those intended by the Manufacturer.
- Do not use or let the machine be used with defective, deactivated and/or incorrectly installed safety devices.
- Do not continue to use the machine if malfunctions have been detected.
- Stop the machine immediately and restart it only after the normal conditions of use have been restored.
- Never carry out any intervention with the machine running, but only after stopping it properly, under safety conditions (see paragraph “machine safe stop”).
- Never use the machine without wearing the Personal Protective Equipment indicated by the Manufacturer and provided for by the laws in force on workplaces, with particular reference to safety shoes.
- Never use the machine if the scheduled maintenance interventions have not been carried out.
- Do not clean or wash the machine with aggressive products to avoid damaging the components.
- Do not replace the components with non-original spare parts or part with different design and construction features.
- Do not leave the machine unattended at the end of the production activity without shutting it down first in safety conditions (see paragraph “machine safe stop”).

### 2.4.2. EMPLOYER OBLIGATIONS

- The operator must be trained to acquire the required skills in the field of packaging machines or equivalent. Upon completing the training, ensure that the operator has understood the entire content of the operating manual, in particular the safety information.
- The operator must have the required skills and must be fit for the activities to be carried out in safety conditions.
- The employer must inform the operator on the reasonably foreseeable misuses and on the persistent residual risks.
- The operator must be capable of reading and understanding the user manual and must easily identify the safety signs.
- Allow the machine to be used only by operators that are properly trained, informed and authorised.



#### **Important**

**The employer must document the training carried out for the operators.**

## 2.5. SAFETY WARNINGS ON RESIDUAL RISKS



### Danger - warning

During design and manufacturing, the Manufacturer has paid particular attention to the residual risks that may affect the safety and health of the operators.

The residual risks are: "all the risks that persists although all safety solutions have been applied and integrated during machine design".

The list specifies the residual risks specific for this type of machine.



### Risk of shearing upper limbs:

Do not insert your hands inside.

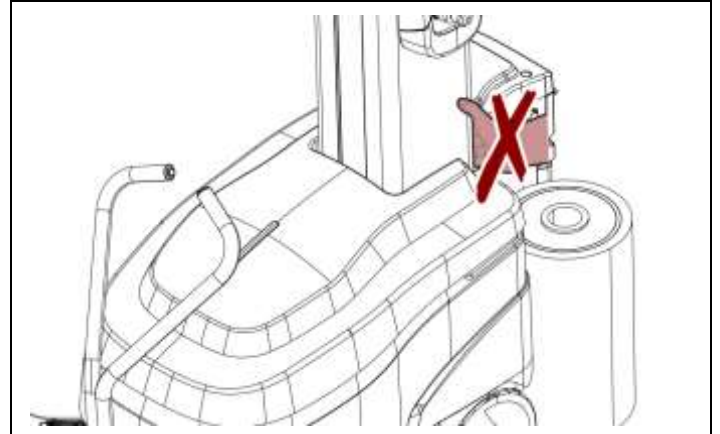

### Risk of crushing upper limbs:

To close the battery casing, lower it slowly and avoid placing your hands in-between.

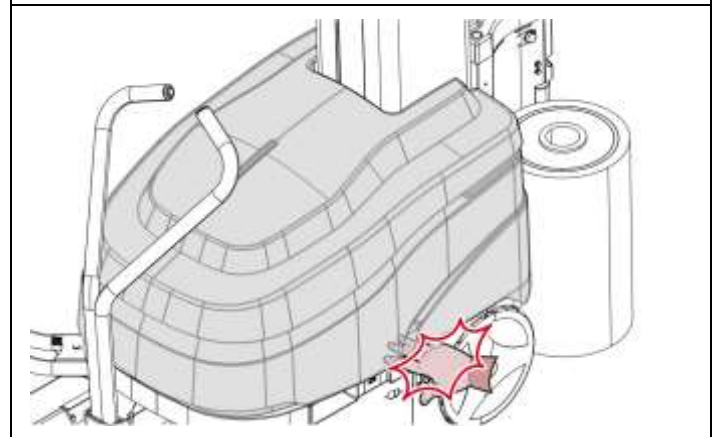

### Hand crushing danger:

Take care not to put your hands in the gap when closing the reel casing.

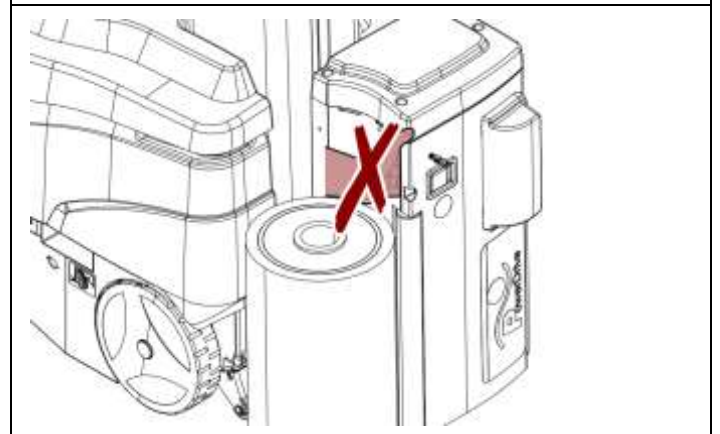

### Danger of short-circuiting battery terminals:

It is forbidden to remove the battery terminal guard as this may cause a short circuit.



**Risk of impact and body trapping:**  
Do not stand in the machine operating area.



**Risk of impact and crushing of body parts:**  
Do not stand in the machine operating area.

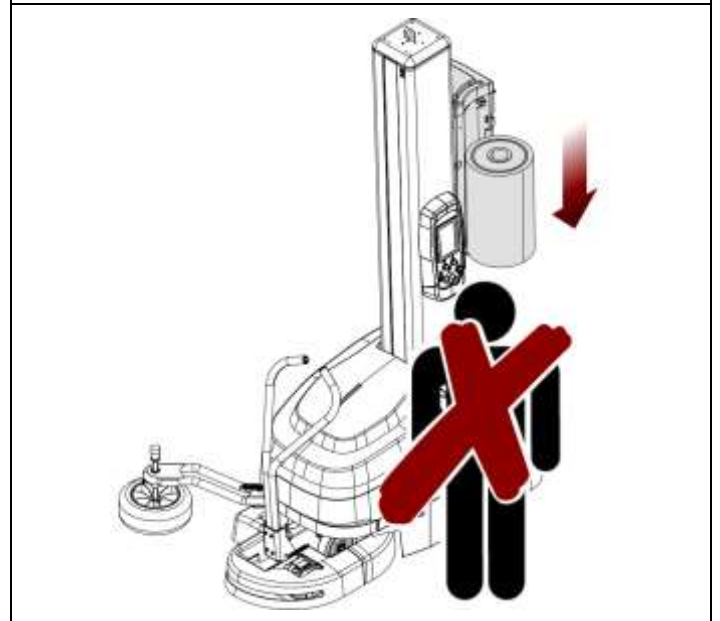

## 2.6. SAFETY WARNINGS FOR ADJUSTMENTS AND MAINTENANCE



### **Danger - warning**

Keep the machine in maximum efficiency conditions and perform all the scheduled maintenance operations provided for by the Manufacturer.

Proper maintenance will provide the best performance, a longer life span and constant compliance with safety requirements.

Before any maintenance operation stop the machine in safe conditions (see paragraph “machine safe stop”).

Enable all machine safety devices before performing any maintenance and adjustment operations.

Mark the surrounding areas and implement adequate safety measures, as provided for by the standards on safety at work, in order to prevent and minimise the risks.

Maintenance interventions in areas that are not easily accessible or dangerous must be carried out after having made sure that the necessary conditions are met.

The personnel authorised to carry out the ordinary maintenance (adjustments, replacements etc.) must possess the necessary technical and professional knowledge and skills.

Do not carry out interventions other than those indicated in the user manual without the express authorisation of the Manufacturer.

Do not use products that contain corrosive and flammable substances or that are harmful to people's health.

Always wear the Personal Protective Equipment indicated in the “Instructions for use”, **in particular safety shoes**, and that provided for by the laws in force on matter of safety in the workplace.

The use of similar but non-original spare parts may result in improper repairs, altered performance and economic damage.

Use lubricants (oils and greases) recommended by the Manufacturer or with similar chemical-physical features.

Do not dispose of polluting liquids, worn parts and maintenance waste into the environment.

Select the components according to the chemical and physical features of the material and dispose of them separately in accordance with the applicable laws.

All the extraordinary maintenance interventions shall be carried out only by authorised personnel with experience and expertise in the field of intervention.



### **Important**

**Non-compliance with the instructions given may cause risks to the safety and health of people, as well as economic damages.**

## 2.7. SAFETY WARNING FOR THE ELECTRICAL EQUIPMENT

The electrical equipment has been designed and manufactured in accordance with the relevant standards. These standards consider operating conditions based on the surrounding environment.

The list contains the conditions necessary for the correct operation of the electrical equipment.

- Ambient temperature must be within **0°C** and **40°C**.
- The relative humidity should be between **50%** (measured at **40°C**) and **90%** (measured at **20°C**).
- The installation environment must be immune to and must not be a source of electromagnetic interference or radiation (x-rays, lasers, etc.).
- The environment must not have areas with concentrations of gas and dust that are potentially explosive and/or with a fire risk.
- The products and materials used during production and maintenance must not contain contaminants or corrosive agents (acids, chemicals, salts, etc.) and must not be able to penetrate and/or come into contact with electrical components.
- During transport and storage, the ambient temperature must be between **-25°C** and **55°C**.
- The electrical equipment may still be exposed to a temperature of up to **70°C** provided that the exposure time does not exceed **24** hours.
- The electrical equipment operates correctly up to **1000 m** above sea level.



### **Important**

If it is not possible to comply with one or more of the conditions listed, which are essential for the correct operation of the electrical equipment, it is necessary to agree at the contractual stage which additional solutions to adopt in order to create the most suitable conditions (e.g. specific electrical components, air conditioning equipment, etc.).

## 2.8. INFORMATION AND SAFETY SIGNS

The figure indicates the position of the safety and information signs affixed to the machine.  
For each sign the relative description is specified.

- A) **Warning sign:** it indicates that “the battery must be charged in a suitable well ventilated room, outside of the work environment”.
- B) **Prohibition sign:** do not act on the component with your hands.
- C) **Warning sign:** it indicates the component weight.
- D) **Danger sign:** danger of pole tipping.
- E) **Warning sign:** it indicates that the accumulator batteries must be charged after a prolonged period of inactivity.
- F) **Information sign (applied in transport phase):** it provides contraindications and indicates how to prepare the machine for use after the transport phase.
- G) **Information sign (applied in transport phase):** it indicates how to remove the pallet from the machine.
- H) **Information sign (applied in transport phase):** it indicates the conditions for lifting the column.
- I) **Information sign:** It indicates the lifting points with fork device.
- J) **Information sign:** It indicates the lifting points with hook device.



### Danger - warning

The hook is provided only for lifting the pole during installation.  
Do not use it to lift the entire machine.

- K) **Electrical hazard sign:** do not access the area to avoid risks of electric shock or electrocution.
- L) **Information sign:** Carefully read the manual before performing any type of intervention.
- M) **Prohibition sign:** it indicates that the operation must not be performed by more than one person.
- N) **Information sign:** it indicates that the button is used to unwind the film.
- O) **Information sign:** it indicates wheel nut tightening direction.
- P) **Danger sign:** hand crushing danger.
- Q) **Information sign:** it indicates tyre pressure level.
- R) **Danger sign:** foot crushing danger.
- S) **Danger sign:** hand crushing danger.
- T) **Information sign:** it indicates that the button is used to reset the machine.



### Important

Make sure that the nameplates are clearly legible.  
If not, replace and reposition them at the original position.

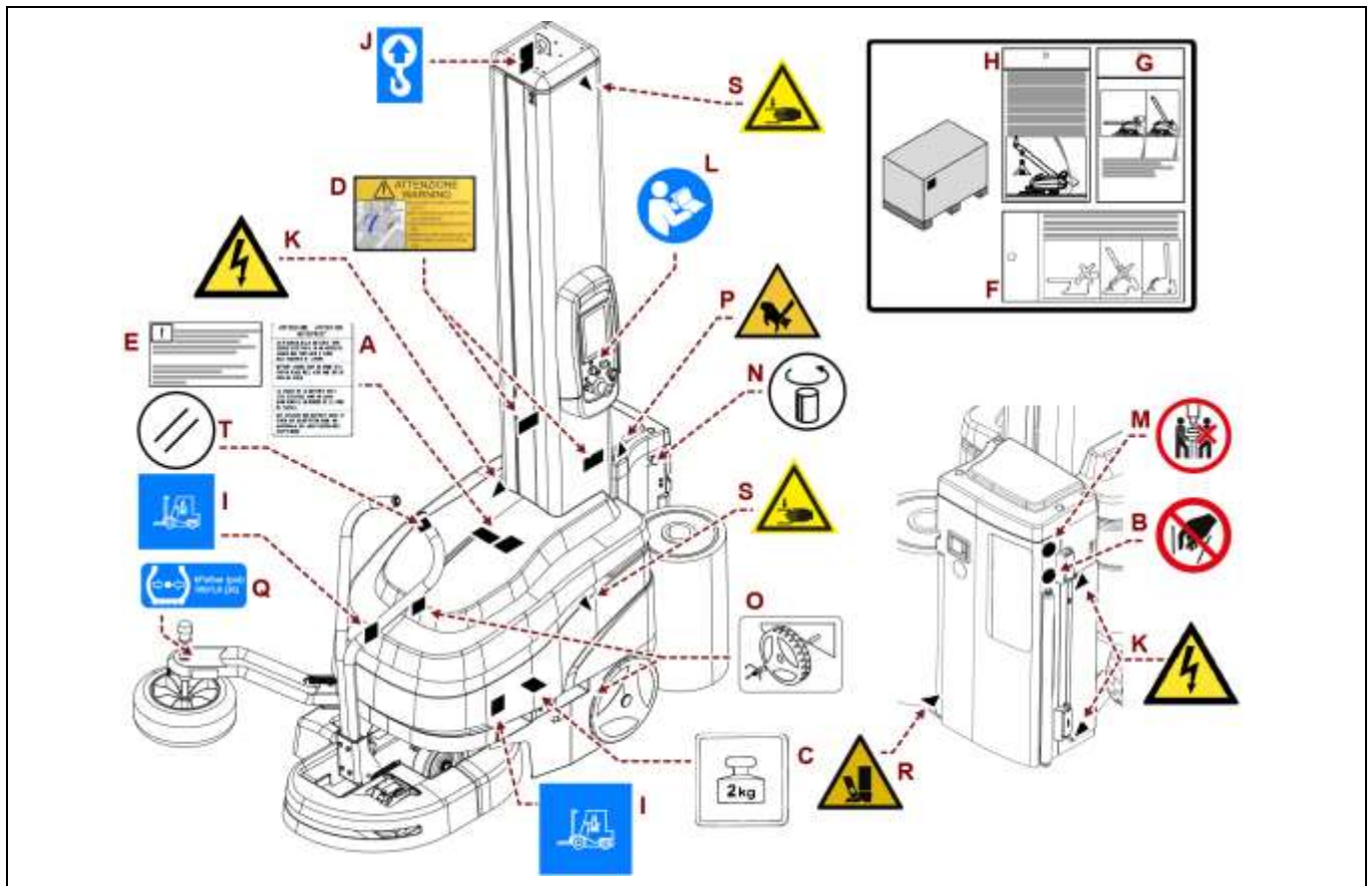

## 2.9. PERIMETER AREAS

The illustration shows the perimeter working areas of the machine.

1. Machine operating area.
2. Perimeter area.

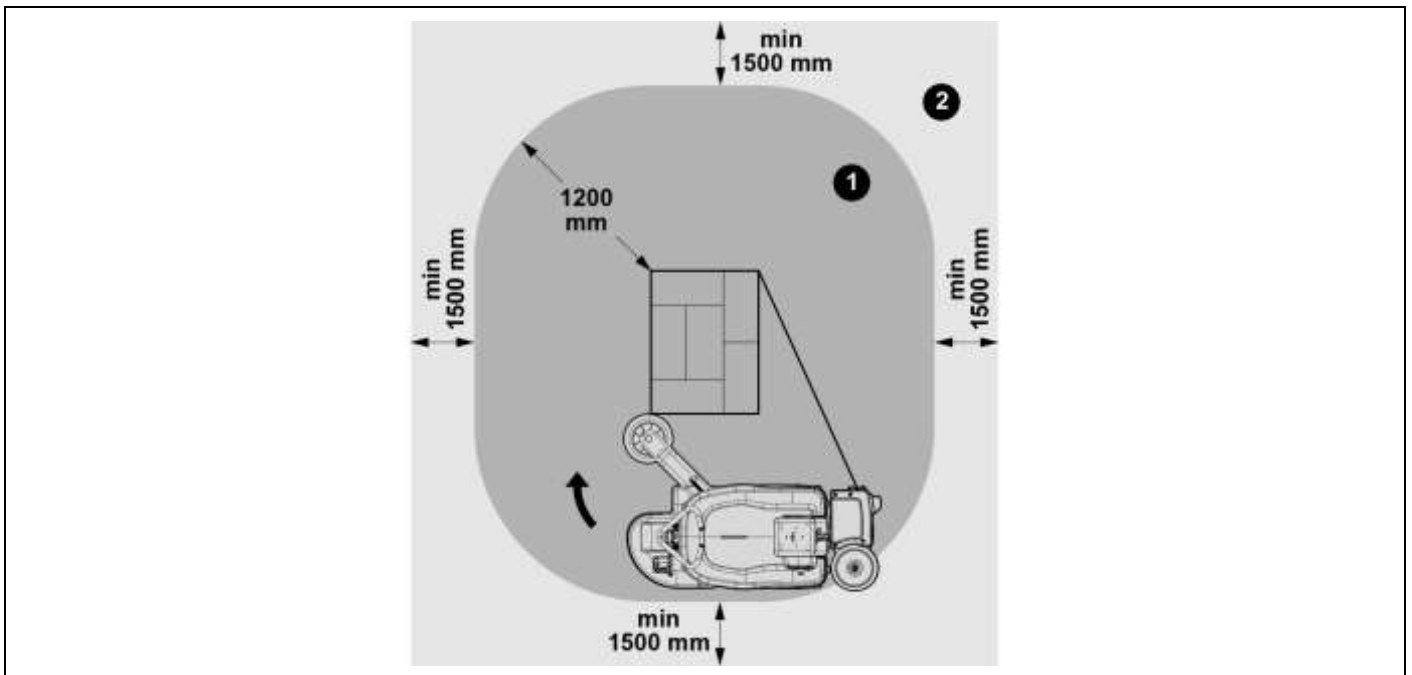

## 2.10.MACHINE SAFE STOP

To stop the machine safely, perform the following procedure:

1. Move the carriage all the way down;
2. Press the emergency stop button;
3. Open the battery casing (A);
4. Disconnect connector (B);
5. Close the battery casing (A) again.



### **Danger - warning**

Disconnect connectors (B) using the special handle (C).

Do not disconnect connectors directly on the cables as they may be damaged, exposing the operator to the risk of electric shock.



### **Danger - warning**

Should it not be possible to lower the carriage, the stop at different heights can be considered safe only for film insertion operations. For the other activities on the carriage, this latter must be kept in the correct position through the use of external means, such as a support.

Follow the instructions provided in paragraph "Adjustment of the lifting chain of the reel carriage" for the tensioning of the chain.

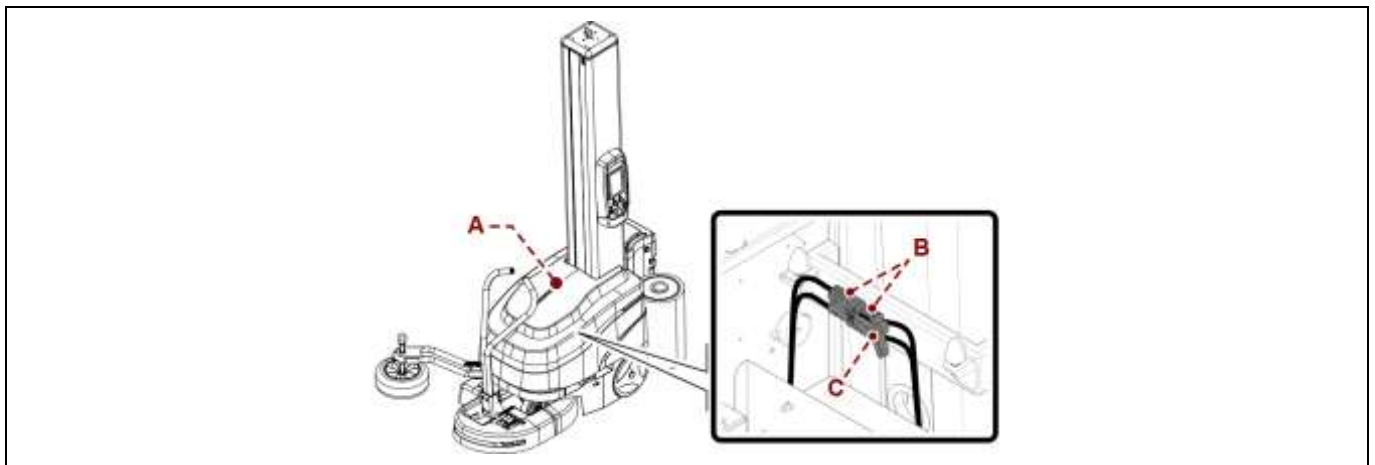

### 3. TECHNICAL INFORMATION

#### 3.1. MACHINE GENERAL DESCRIPTION

- Robot S7 is a semi-automatic self-propelled machine used to wrap and stabilise palletised loads with stretch film.
- The machine is suitable for installation in workshops and factories, protected against weather conditions. The installation surface must be levelled and even, to allow the machine to easily move around the pallet.
- **Only one operator is required** to move the machine closer to the pallet, tie the film, perform the cutting at the end of the wrapping and reload the reel.
- **If the machine is equipped with an automatic cutting device, the film will be automatically cut at the end of each wrapping cycle.**
- Stretch film reels commonly available on the market are used for load wrapping (see paragraph “reel features”).
- The machine must be used only for wrapping and stabilising products contained in packages (boxes, liquid containers, etc.) with regular shape or with a shape that ensures a stable palletisation.
- Packages containing liquids or insubstantial materials must have characteristics suitable to the product and be perfectly closed and sealed to prevent the contents from flowing out.
- The machine is equipped with a series of safety devices designed to avoid any injuries to the operator or other persons using the machine.
- The machine structure features seats for lifting operations (right and left side, column side) with a fork device.
- The machine comes in different models to satisfy different market needs.

The illustration shows, for information purposes only, the machine models, and the legend lists the parts.

Legend:

- A) Sliding column:**  
for the vertical handling of the film carriage.
- B) Film carriage:**  
it includes different reel film stretching and pre-stretching devices.  
For further details, refer to the table "film carriage characteristics".  
The vertical movement is controlled by the gearmotor (C), operated by an electric motor powered by the batteries (L).
- D) Driving wheel:**  
it is operated by the electric motor (F), powered by the battery (L). This wheel is equipped with an electromagnetic brake.  
The electromagnetic brake locks the drive wheel if the battery power supply is interrupted because of a failure (e.g. broken element) or when the machine is stopped (emergency or cycle Stop).  
When the driving wheel is locked, the machine can be moved only over short distances using the small backup wheel (G).
- E) Idle wheel:**  
It is aligned with the drive wheel (D).
- G) Backup wheel:**  
by means of lever (H), it allows lifting the locked driving wheel (D) from the ground, in order to move the machine over short distances.



**Important**

When transporting the robot with the lifting wheel, disconnect the battery disconnect switch.

- J) Rudder:**  
it is equipped with leading wheels (I) and is used to manually move the machine.
- K) Feeler:**  
it is used to follow the pallet perimeter during the wrapping cycle.
- L) Accumulator batteries:**  
they power the electric motors and the electric circuit.
- M) Safety laser-scanner:**  
a safety device that detects obstacles within the working area and causes the machine to stop.  
For further details, see the paragraph "description of safety devices".
- N) Control panel:**  
it is equipped with electromechanical controls and a touch-screen display for the programming of the wrapping parameters.
- O) Battery charger:**  
it is electronic and is used to recharge the accumulator batteries.

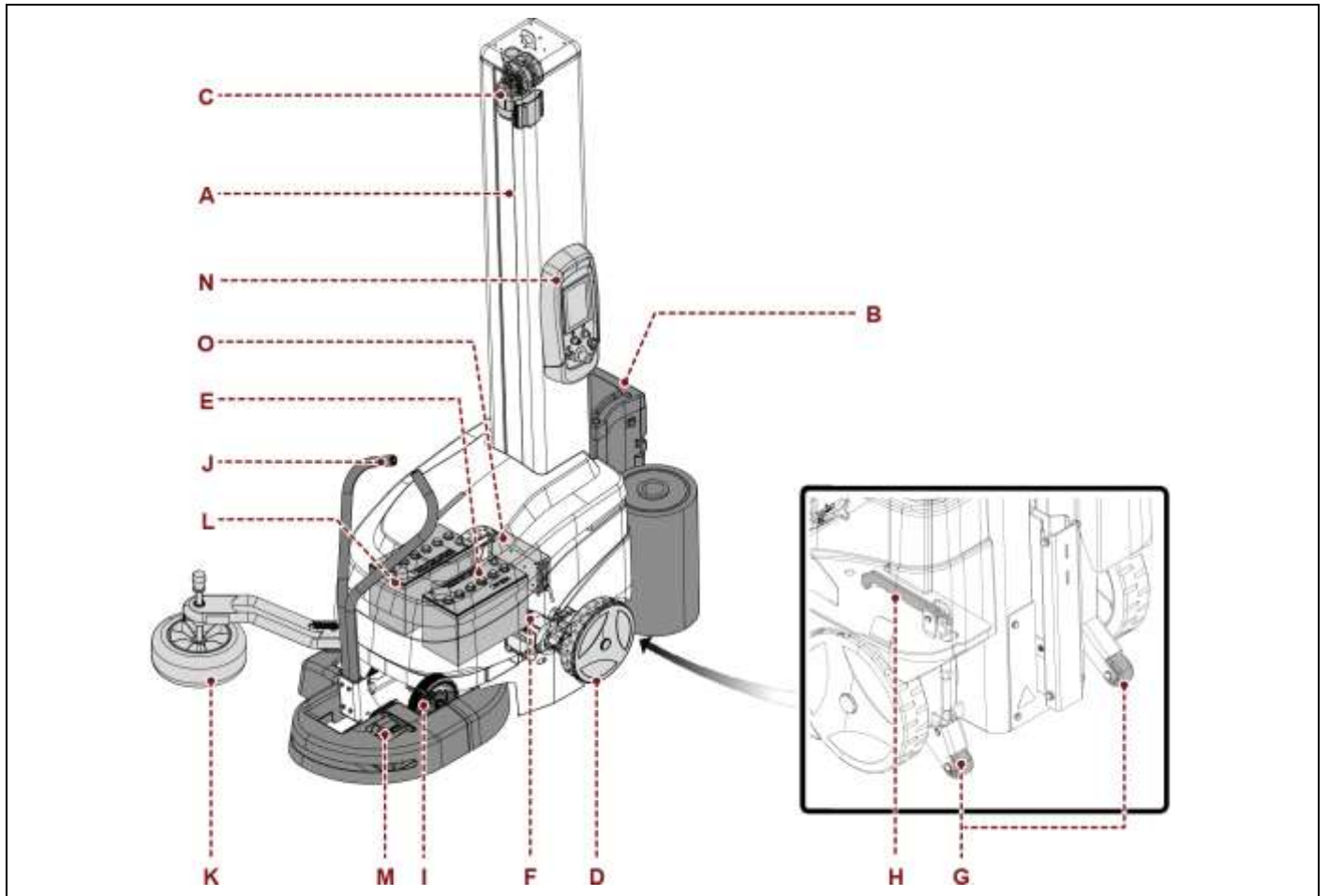

### 3.1.1. MACHINE MODELS DESCRIPTION

Table: Film carriage features

Film carriage type	General features
FRD	Film carriage of the FRD and "FRD for mesh" type with roller with clutch, mechanical brake and manual adjustment of film stretch.
FR	Film carriage of the FR type with roller with clutch, electromagnetic brake and film stretch adjustment from control panel.
P3GS	Film carriage of the P3GS type with motorised pre-stretch rollers and electronically controlled film tensioning. Pre-stretch can be adjusted through the mechanical switch located on rubber roller (300%-230%-0%) (250%-150%-0%).
PVS	Film carriage of the PVS type with dual-motor pre-stretch rollers and electronically controlled film tensioning. Pre-stretch can be adjusted from the control panel (0%+400%).

### 3.2. DESCRIPTION OF OPERATING CYCLE AND WRAPPING MODES

#### 3.2.1. DESCRIPTION OF THE OPERATION CYCLE

##### Phase 1

The operator approaches the machine until the feeler wheel is in contact with the pallet, then ties the end of the film to the pallet and starts the wrapping cycle.

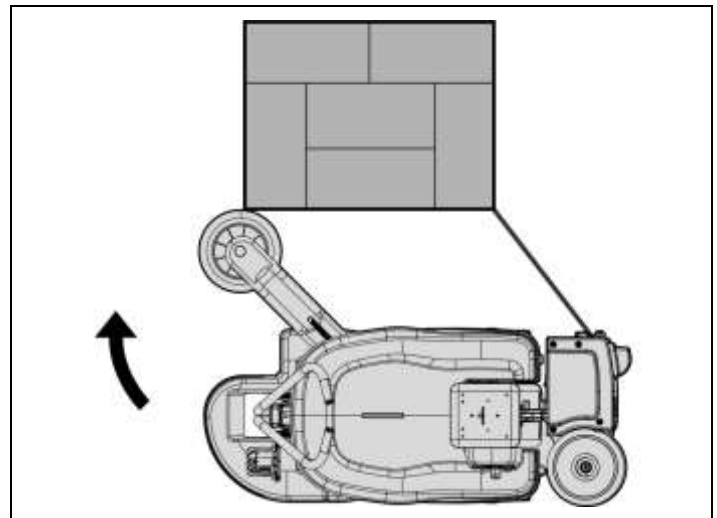

##### Phase 2

The machine turns clockwise around the pallet, while the film carriage rises and unwinds the film according to the set parameters.

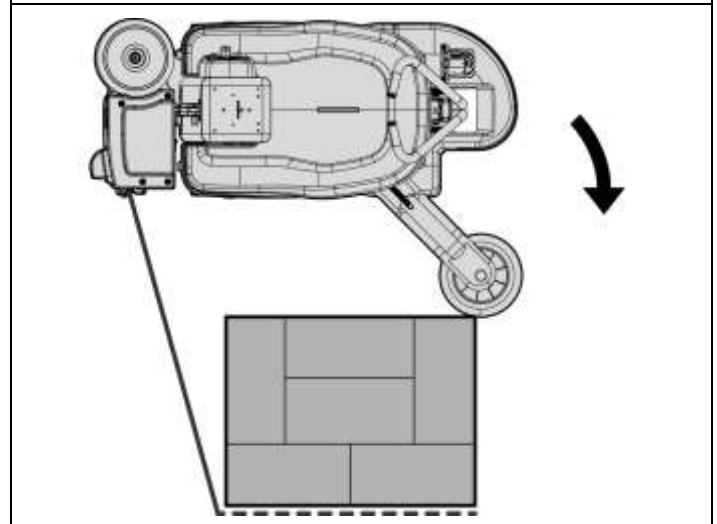

##### Phase 3

Once the wrapping is complete, the machine stops. Cut the film (manual or automatic mode) and then start it to wrap the next pallet.

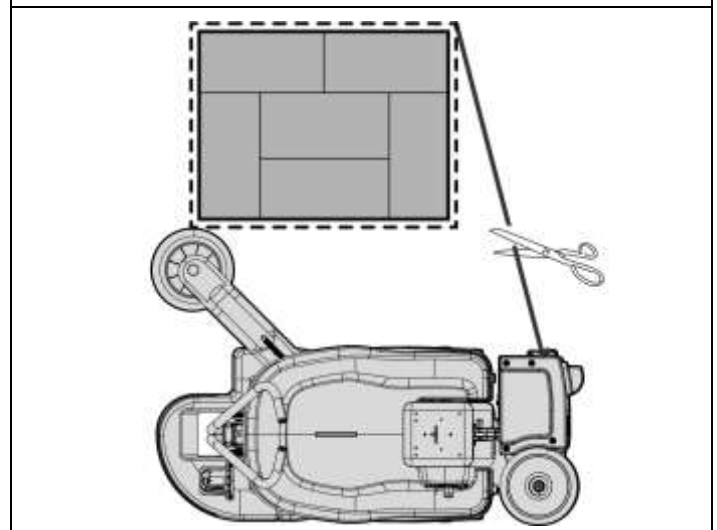

### 3.2.2. WRAPPING MODES

#### Single wrapping

It starts at the base of the pallet (with a series of stabilising wrappings) and then stops at the top after completing the final wrapping.

To start a new wrapping phase from the base, the spool carriage must be lowered using the manual controls.

- 1) **START**
- 2) **Stop**

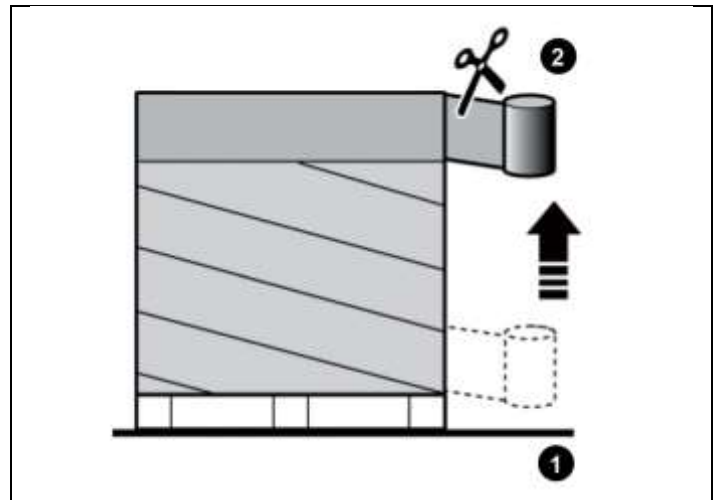

#### Double wrapping

It starts at the base of the pallet (with a series of stabilising wrappings) up to the top side.

After performing a reinforcement wrapping at the top, the wrapping process continues to the bottom and stops after performing the final wrapping.

- 1) **START**  
**Stop**

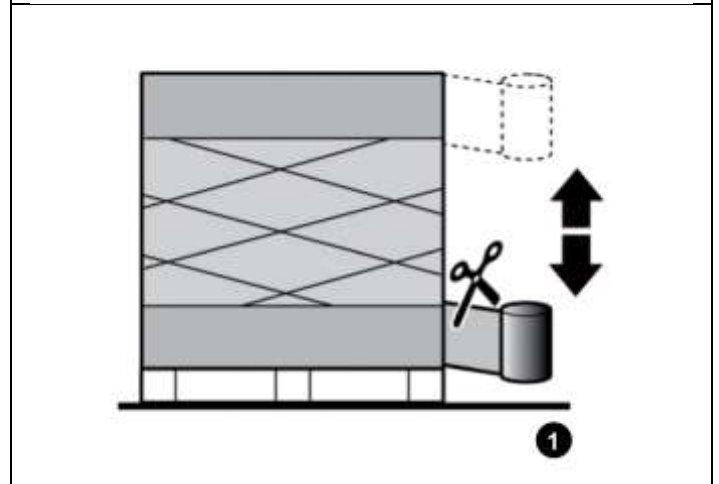

#### Double wrapping with feeder

It starts at the base of the pallet (with a series of stabilising wrappings) and then momentarily stops at the top side.

After the protection sheet (**TOP**) has been added, the operator resumes the wrapping cycle using the relevant control.

After performing a reinforcement wrapping at the top, the wrapping process continues to the bottom and stops after performing the final wrapping.

- 1) **START**  
**Stop**
- 2) **START**  
**Stop**

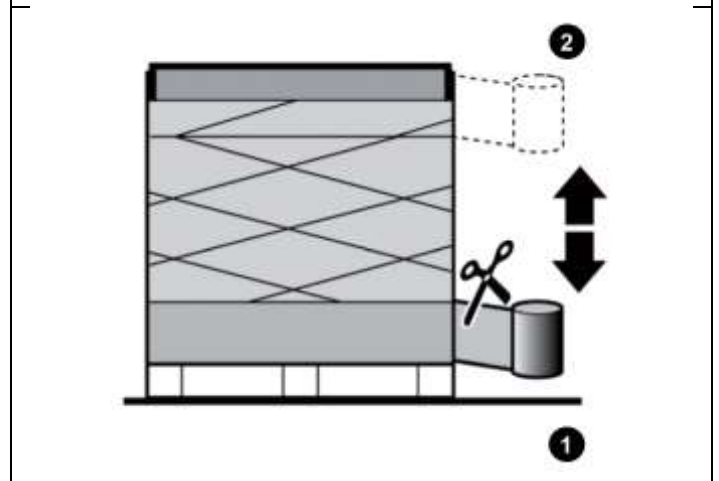

### 3.3. SAFETY DEVICE DESCRIPTION

The figure shows the position of the devices on the machine.

**A) Safety laser-scanner**

If the laser scanner detects an obstacle, it stops the machine feeding and the wrapping phase. If the safety area is cleared within 15 seconds the machine beeps and resumes the wrapping cycle. If the safety area is not cleared within the specified time, a reset by the operator is required. Restart the machine by pressing the Start button. For further details, see paragraph "wrapping start and stop".

**B) Emergency stop button**

it is used in case of imminent risk to stop, with a voluntary action, the machine parts which may pose a risk. The control must be "locked" until the normal operating conditions have been restored. Restore the normal operating condition, cut the film, unlock the button and press the control to reset the machine. Once the film carriage has reached the starting position, restart the machine to repeat the wrapping. For further details, see paragraph "wrapping start and stop".

**C) Light indicator**

it signals machine statuses:

- red: machine in emergency;
- flashing blue: machine waiting to be reset;
- green: machine ready to start;
- flashing yellow: machine running.

**D) Acoustic warning device**

it warns that the wrapping cycle has started after 5 seconds.

**E) Phonic wheel**

It detects the actual movement and speed of the machine in the various phases of operation.

**F) Rudder sensor**

It is positioned at the base of the rudder and detects its low position enabling manual movement of the machine.

**G) Safety microswitch**

It detects carriage electric control board opening.

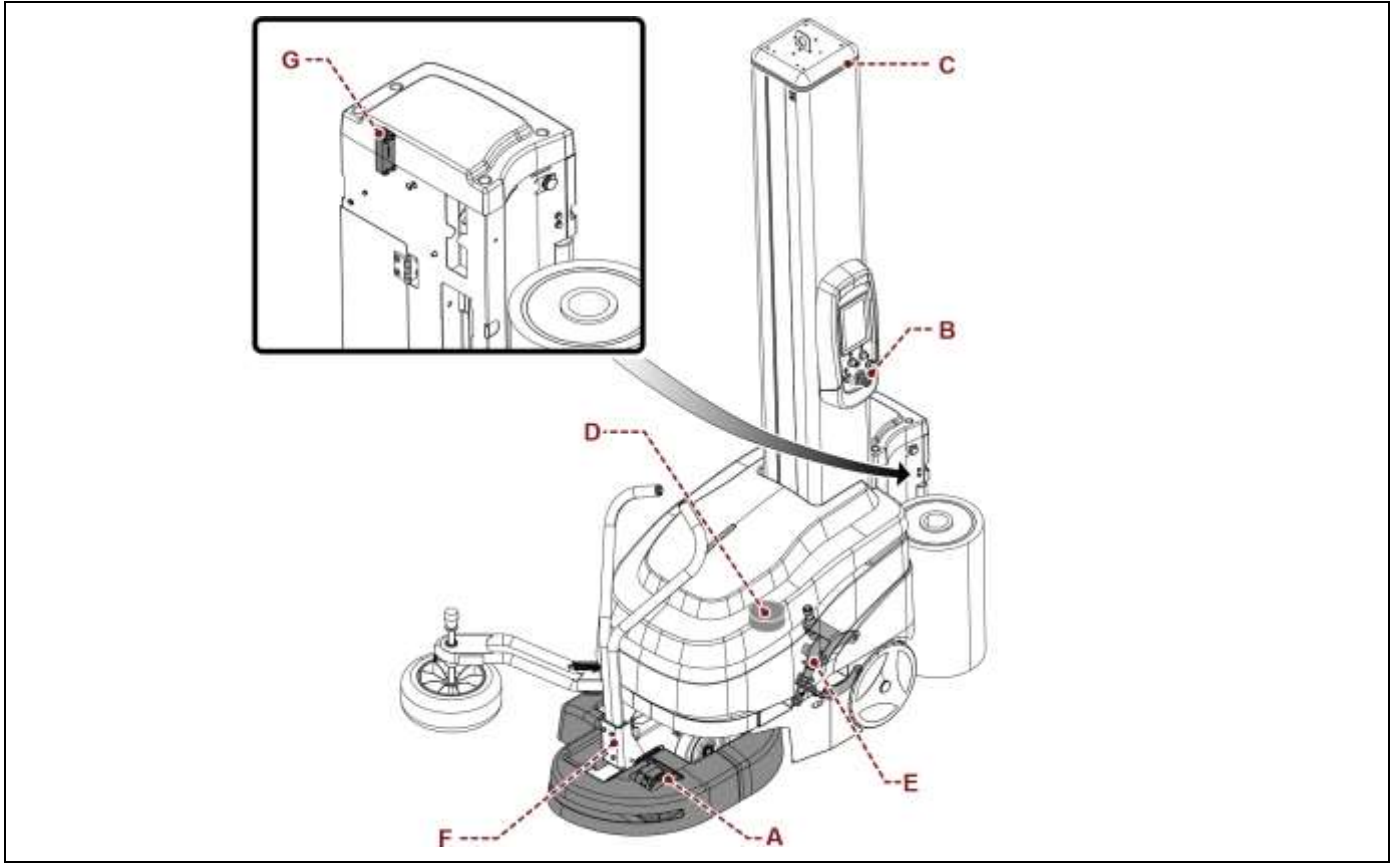

### 3.4. DESCRIPTION OF ELECTRICAL DEVICES

The figure shows the position of the devices on the machine.

- A) **Gearmotor**  
it activates the drive wheel.
- B) **Gearmotor**  
it activates the film carriage movement.
- C) **Accumulator batteries**  
they power the electric motors and the electric circuit.
- D) **Microswitch**  
when the bumper collides with an obstacle, it is activated to stop machine feeding.
- E) **Carriage limit microswitch**  
it is activated when the film carriage reaches the minimum and maximum wrapping height.
- F) **Photocell**  
it detects the height and the presence of the load to be wrapped.
- G) **Battery charge level indicator**  
It indicates battery charge level.
- H) **Main fuse**  
Integrated fuse in the battery connection cable

Information valid only for "P3GS" - "PVS" type film carriages

- I) **"Load cell" sensor**  
it detects the film tensioning and enables the variation of the pre-stretching roller speed.
- J) **Electric motors**  
they power pre-stretch rollers.



**Important**  
For further details see the wiring diagram.

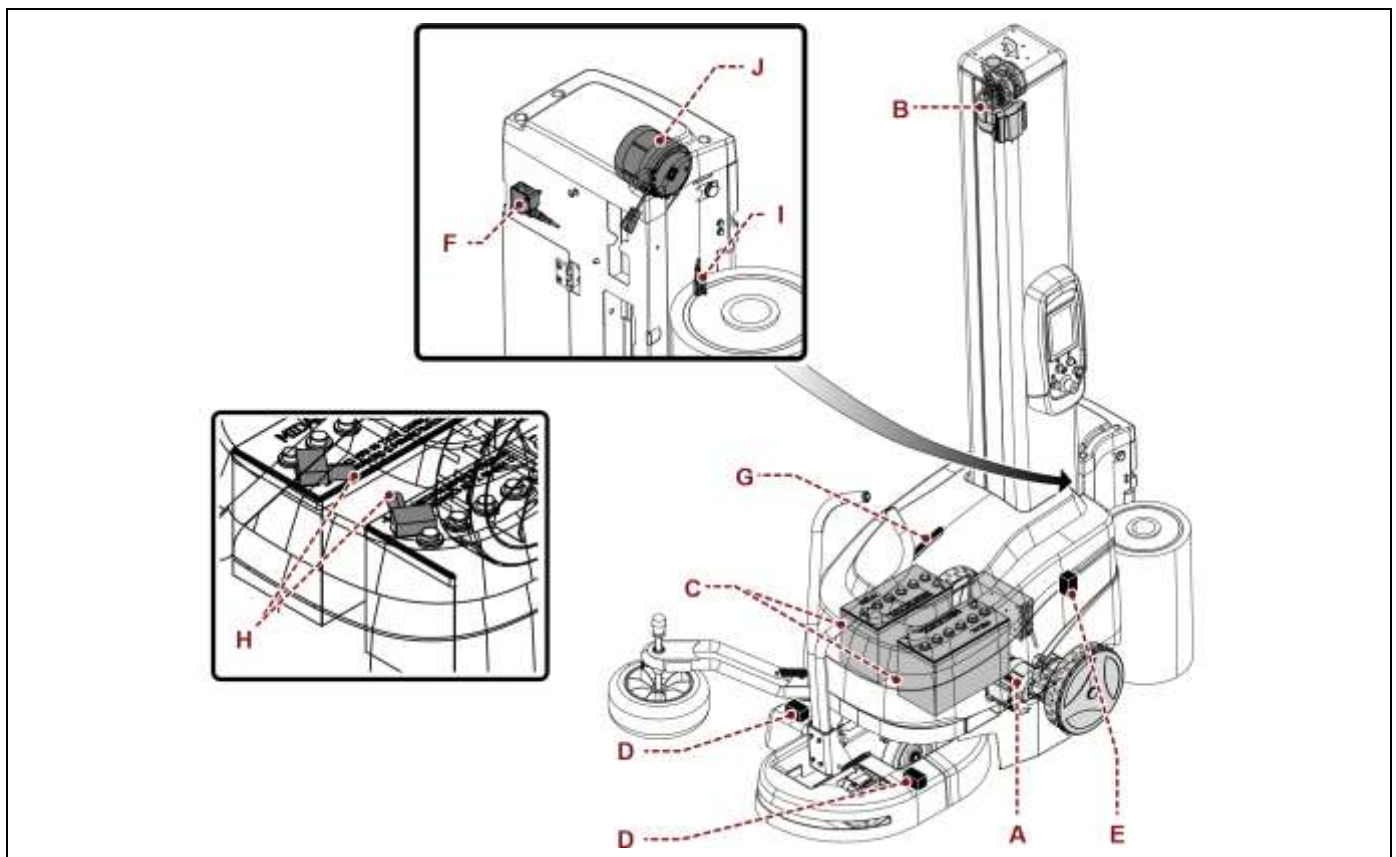

### 3.5. DESCRIPTION OF ACCESSORIES ON REQUEST

To increase the machine performance and versatility, the Manufacturer makes available the following accessories.

- **Stain-resistant wheels**  
Wheels made in a material which reduces the formation of marks on the floor.
- **Additional battery kit**  
it is equipped with a recharging device, two batteries and two trays containing the batteries.  
The kit allows replacing the tray containing low batteries with the tray of the charged batteries in order to reduce the time during which the wrapping activity is stopped.
- **Reel shaft**  
it is designed to use film reels with a core diameter different from the standard one.
- **Film carriage "FRD for mesh"**  
Carriage for pallet wrapping with mesh film.
- **Automatic cutting device**  
it automatically cuts the film at the end of the cycle.
- **Black product photocell**  
its sensitivity level is suitable for detecting also the height of pallets having mostly black surfaces.
- **Sliding column (oversized)**  
they allow wrapping heights up to 2400 mm, 2800 mm and 3100 mm.
- **Double feeler (Ø260+400 mm)**  
it is suitable for wrapping pallets where the product protrudes from the pallet in an irregular way.
- **Feeler with oversized wheel (Ø400 mm)**  
It is suitable for wrapping pallets having a product which is not compact.
- **Film breakage sensor**  
it detects broken film and empty reel.
- **Film carriage with height 750 mm**  
it allows the use of reels with height 750 mm.
- **Lead batteries**
- **Lithium batteries**
- **Dry battery**
- **Gel battery**
- **R-Connect**
- **R-Connect with film reading**
- **Blue light**  
warning light alerting of the presence of the robot
- **Film height adjuster – roping device:**  
The device has a double function during the wrapping of the packaging, it can be used to adjust the height of the film (height adjuster) or to tighten the film and form a reinforcement rope for the packaging.
- **Kit for -5° temperature.**

### 3.6. TECHNICAL SPECIFICATIONS

#### 3.6.1. MACHINE AND PALLET DIMENSIONS

The illustration and the table include the machine dimensional specifications and technical data.

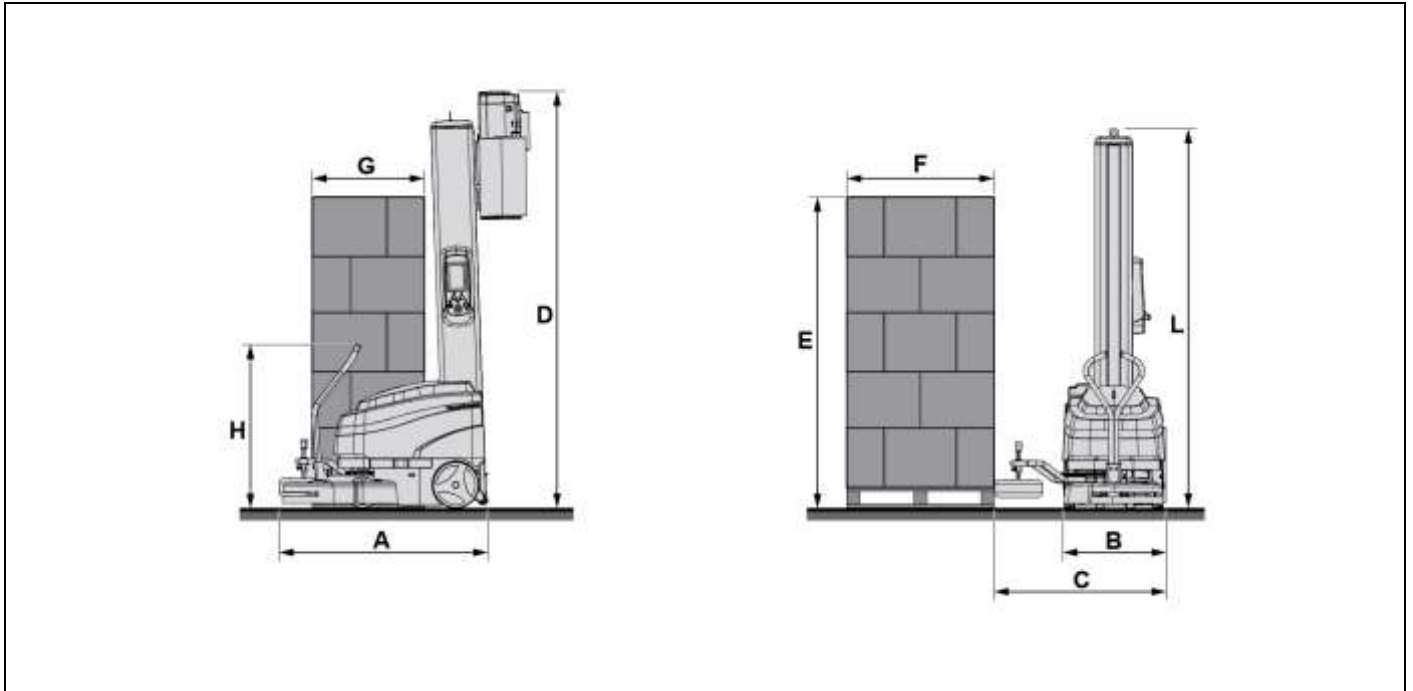

Description	Unit of measurement	Machine model			
		FRD	FR	P3GS	PVS
A - Machine total length	mm	1600			
B - Machine width	mm	686			
C - Machine width with open feeler	mm	1141			
H - Rudder height	mm	1048			
FxG - Pallet dimensions	mm	≥ 600			

#### Standard version

E - Pallet height	mm	2200			
D - Machine maximum height (E) max =	mm	2622	2588	2657	2657
L - Sliding column maximum height (E) max =	mm	2540			

#### Optional version

E - Pallet height	mm	2400			
	mm	2800			
	mm	3100			
D - Machine maximum height (E) max =	mm	2822	2788	2857	2857
(E) max =	mm	3222	3188	3257	3257
(E) max =	mm	-	-	3457	3457
L - Sliding column maximum height (E) max =	mm	2740			
(E) max =	mm	3140			
(E) max =	mm	3340			

### 3.6.2. TECHNICAL FEATURES

Description	Unit of measurement	Machine model			
		FRD	FR	P3GS	PVS
Lithium accumulator batteries	no.	1			
Feeding speed	m/min.	35 ÷ 80			
Carriage upstroke / downstroke speed	m/min.	1.5-5.5 <sup>1</sup>			
Total weight (Standard version)	kg	326	326	356	356
Pallet minimum weight	kg	45			
Ambient operating temperature	°C	0°-40°			

<sup>1</sup> 2÷7.5 m/min with reel height 750 mm.

### 3.6.3. NORDELETTRICA NE284 BATTERY CHARGER

Description	Unit of measurement	Machine model			
		FRD	FR	P3GS	PVS
Supply voltage	Vac	100-240 +/-10% 1Ph			
Electrical current frequency	Hz	50/60			
Installed power	kW	0.5			
Input current	A	5 (100 V) 2 (240 V)			

### 3.6.4. NORDELETTRICA NE328 BATTERY CHARGER FOR LITHIUM-ION BATTERIES

Description	Unit of measurement	Machine model			
		FRD	FR	P3GS	PVS
Supply voltage	Vac	100-240 +/-10% 1Ph			
Electrical current frequency	Hz	50/60			
Installed power	kW	0.8			
Input current	A	8 (100 V) 3.3 (230 V) <sup>3</sup>			

### 3.7. SPOOL TECHNICAL SPECIFICATIONS

#### 3.7.1. SPOOL FEATURES

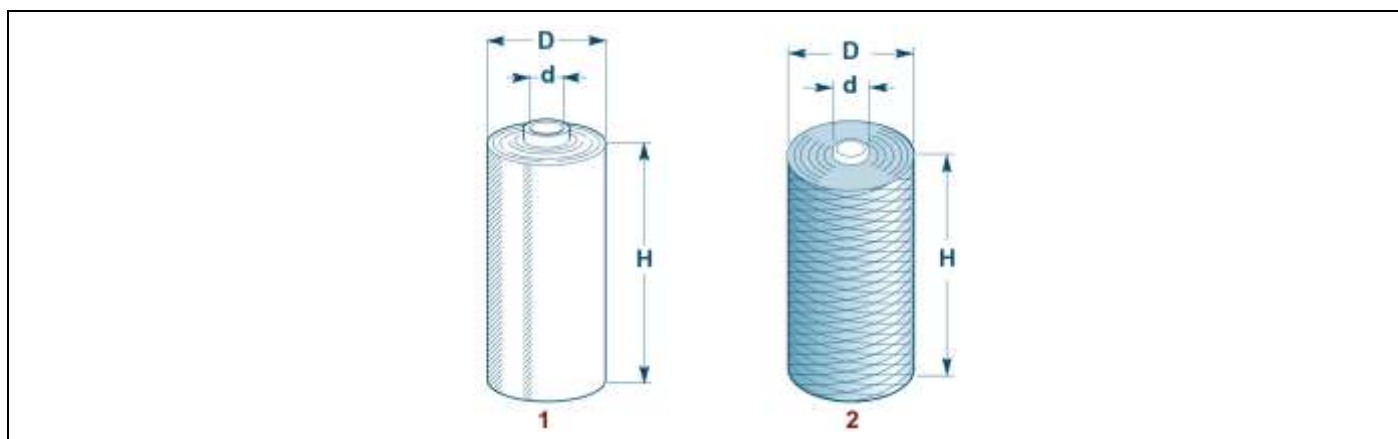

Description	Unit of measurement	Value
<b>Film reel dimensions (1)</b>		
Maximum outer diameter (D)	mm	300
Reel height (H)	mm	500 - 750 <sup>2</sup>
Film thickness	µm	17÷35
Internal diameter (d)	mm	50 <sup>1</sup> - 76
Max. weight	kg	20 - 30 <sup>2</sup>
<b>Mesh reel dimensions (2)</b>		
Maximum outer diameter (D)	mm	300
Reel height (H)	mm	500
Internal diameter (d)	mm	76
Max. weight	kg	20

<sup>1</sup> Install the optional reel shaft.

<sup>2</sup> Reel option H = 750 mm

### 3.8. NOISE LEVEL

The values relating to airborne noise have been detected in compliance with standards:

- EN 415 - 9

Description	A-weighted emission sound pressure measured level at the operator's position (LpA)	Emitted sound power level (Lw)
Operation in working conditions.	64.7 dB (A)	77.5 dB (A)



The use of appropriate protection systems is recommended (earmuffs, ear plugs, etc.).

### 3.9. INSTALLATION ENVIRONMENT CHARACTERISTICS

The place where the machine is to be installed must be carefully selected taking into account the environment conditions in order to have correct and risk-free operating conditions.

Therefore we suggest to take into account the following prerequisites:

- An appropriate ambient temperature (see "Technical data").
- A perimeter area that must be left around the immediate working area, also for safety reasons (see "Perimeter areas").
- A flat surface, steady and without vibrations with adequate load bearing capacity, considering also the weight of palletised loads.
- The area must feature suitable sockets for compressed air and power distribution.



#### **Danger - warning**

Using this machine in explosive environments or when exposed to atmospheric agents is strictly forbidden.

## 4. INFORMATION ON HANDLING AND INSTALLATION

### 4.1. RECOMMENDATIONS FOR HANDLING AND LOADING

- Before performing any operation, the authorised operator must make sure to have understood the "Instructions for use".
- Carefully read the "Instructions for use" specified in the manual and those applied directly to the machine and/or the package.
- Provide suitable safety conditions in compliance with the regulations on workplace safety to prevent and minimise the risks.
- Pay attention to the safety warnings, do not misuse the machine and assess the possible residual risks.



#### Caution - warning

Batteries should be charged as soon as the machine is unpacked.

If the robot is stored without being used, it should be charged at least once every three months.

### 4.2. PACKING AND UNPACKING

The packing is realised, keeping the overall dimensions limited, also in consideration of the transport chosen. To facilitate transport, shipping can be performed with some components disassembled and appropriately protected and packaged.

Some parts, especially electrical equipment, are protected with anti-moisture nylon covers.

The packages bear all necessary information for loading and unloading.

When unpacking, check the integrity and exact quantity of the components.

Packaging material should be appropriately disposed of according to the laws in force.

The illustrations show the common types of packaging used.

#### Package on pallet with nylon protection

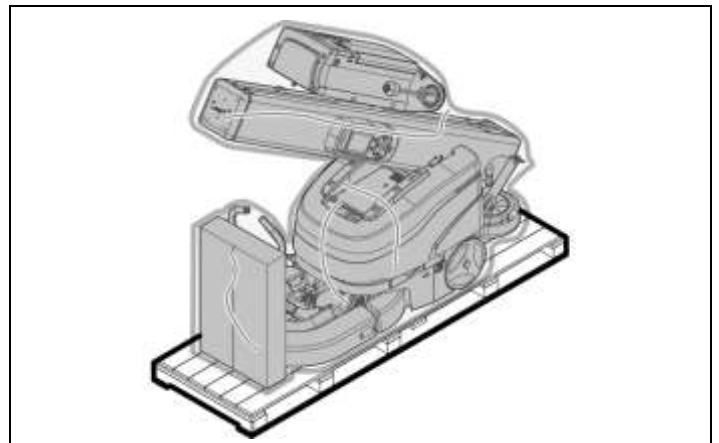

#### Package in crate

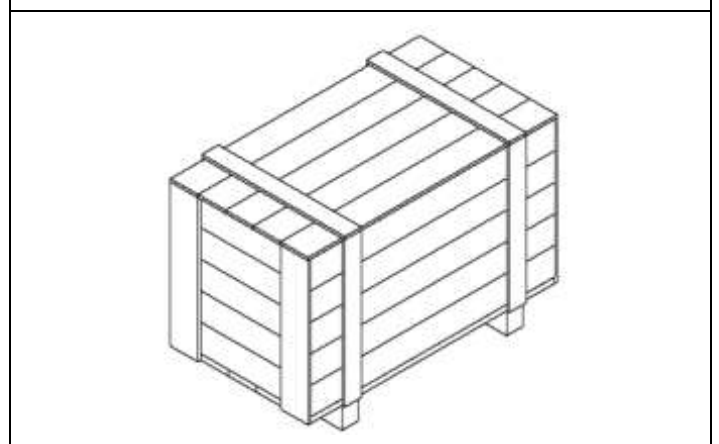

Package with cardboard box

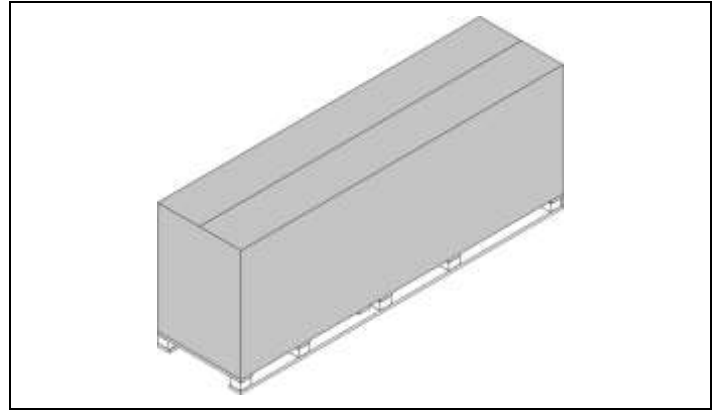

### 4.3. TRANSPORT AND HANDLING

Transport, also according to the destination, can be performed with different vehicles. The diagram represents the most used solutions.



**Important**

For the transport use appropriate means with suitable load-bearing capacity.

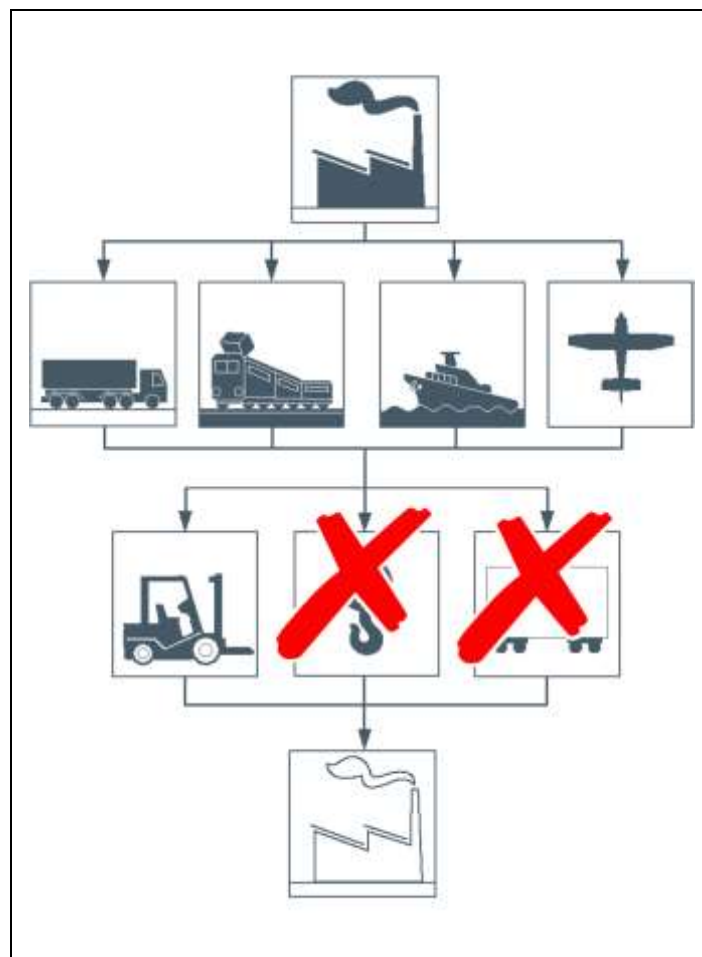

#### 4.4. INSTALLATION OF DISASSEMBLED PARTS

##### 4.4.1. INSTALLATION (WITH TILTED COLUMN)

Proceed as follows.

1. Hook the lifting device to the eyebolt (A) to keep the column in the correct position.
2. Lift the column (B).
3. Tighten the fastening screws (C-D).
4. Tighten the screws (E) fastening the hinge.
5. Disengage the lifting device.

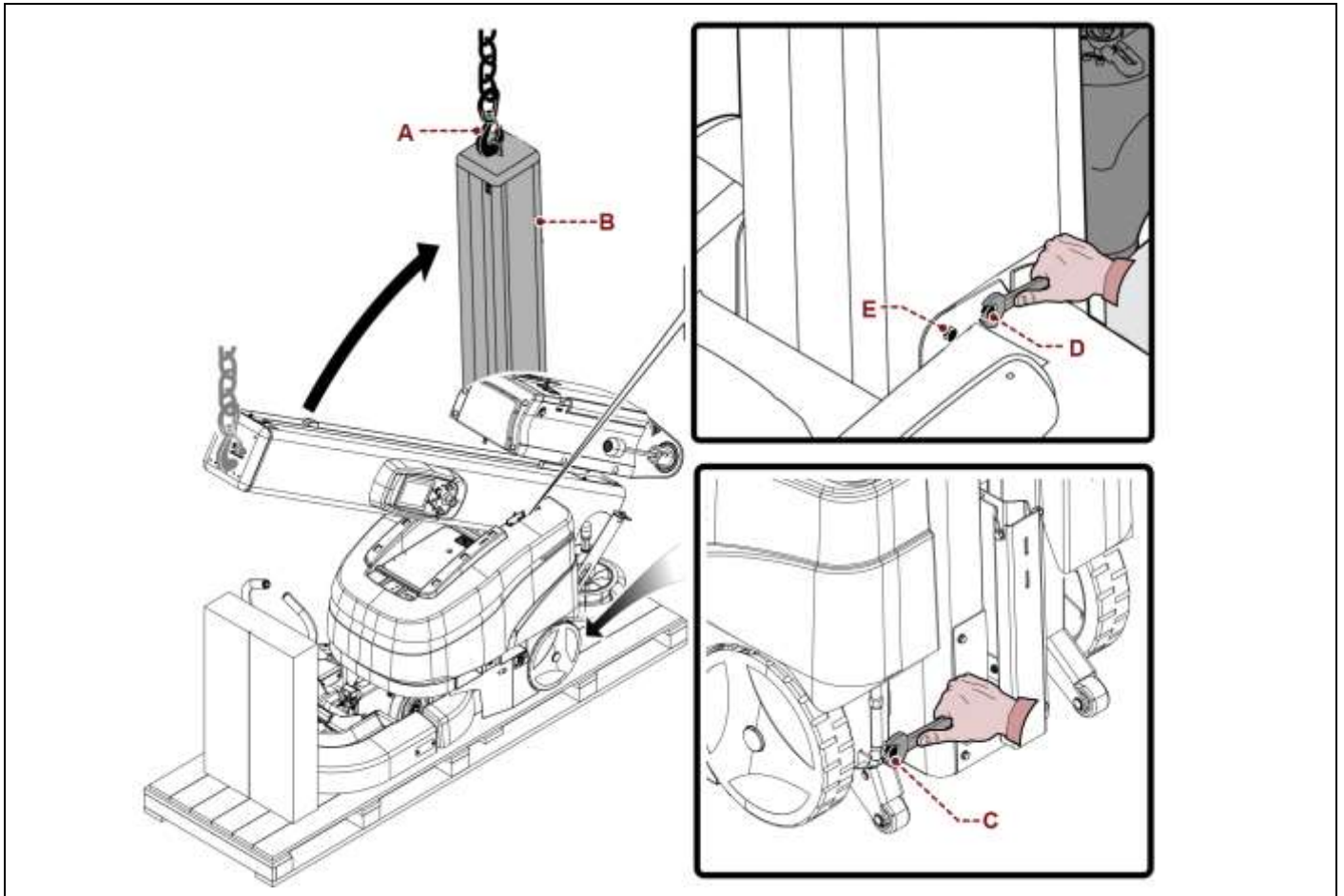

#### 4.4.2. INSTALLATION (WITH HORIZONTAL COLUMN)

Proceed as follows.

1. Hook the lifting device to the eyebolt (A) and lift the column (B).
2. Tighten the fastening screws (C-D).
3. Tighten the screws (E) fastening the hinge.
4. Disengage the lifting device.

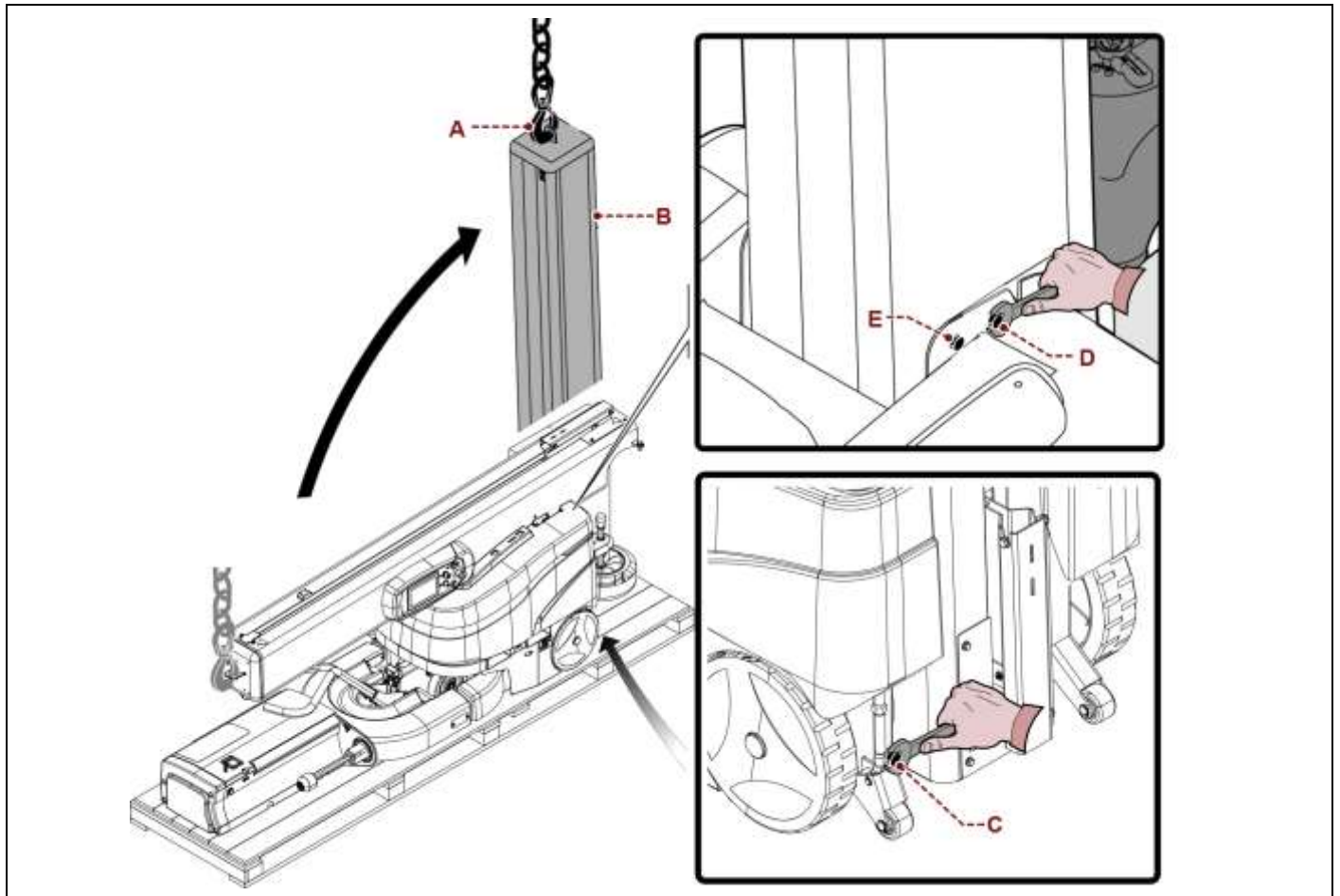

5. Turn on the machine, press the reset button and, using the manual movements, lower the carriage guide (F) to the useful height.
6. Disconnect the terminal (G) from the carriage guide (F).

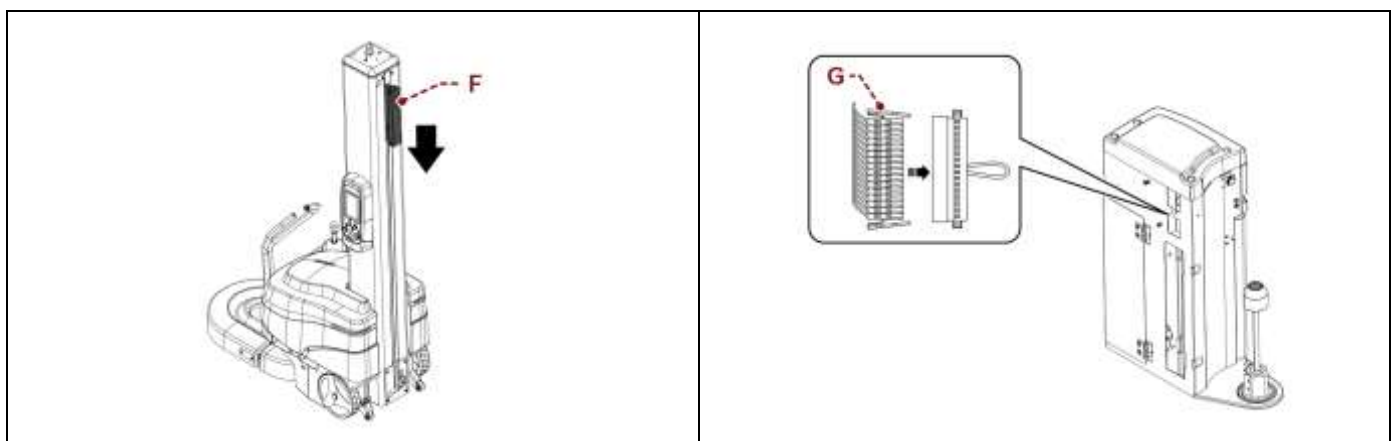

7. Position the film carriage by engaging the screw (H) in the groove (I).

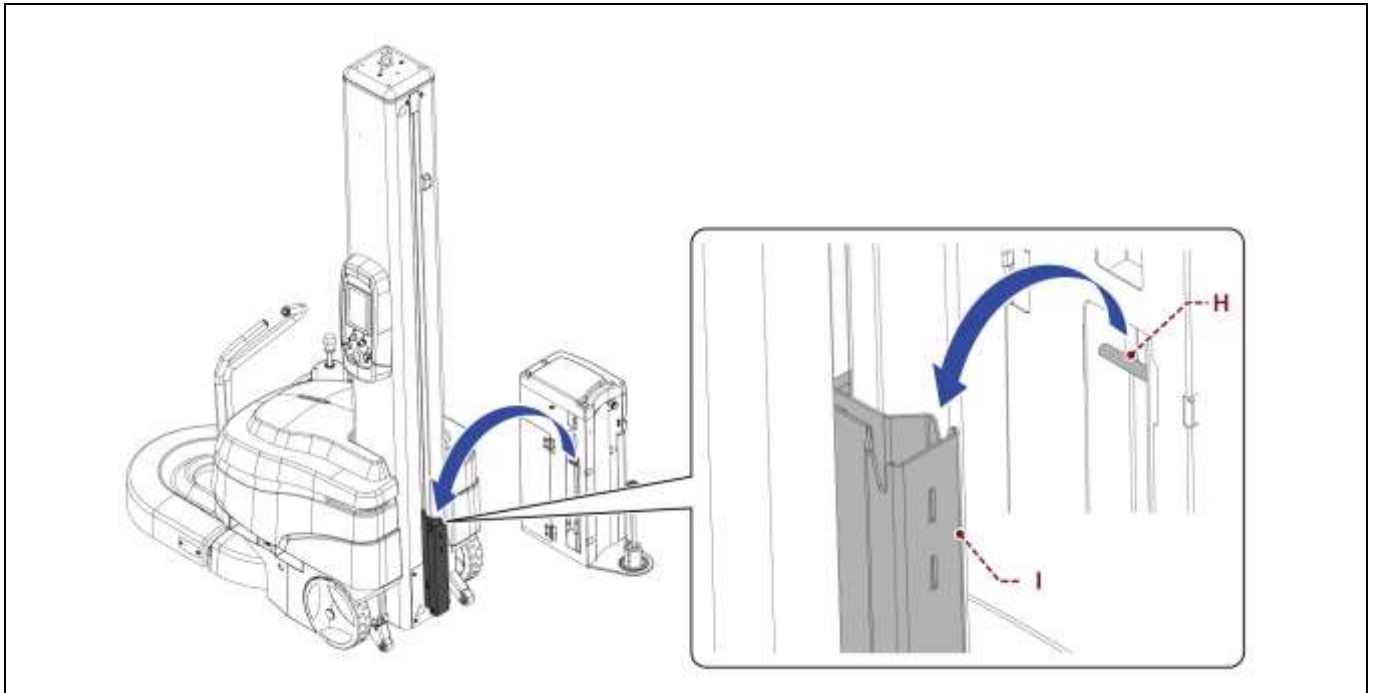

- 8. Secure the carriage with the screw (J).
- 9. Connect the electric connector (G) to the film carriage terminal block.
- 10. Mount the guard (K).

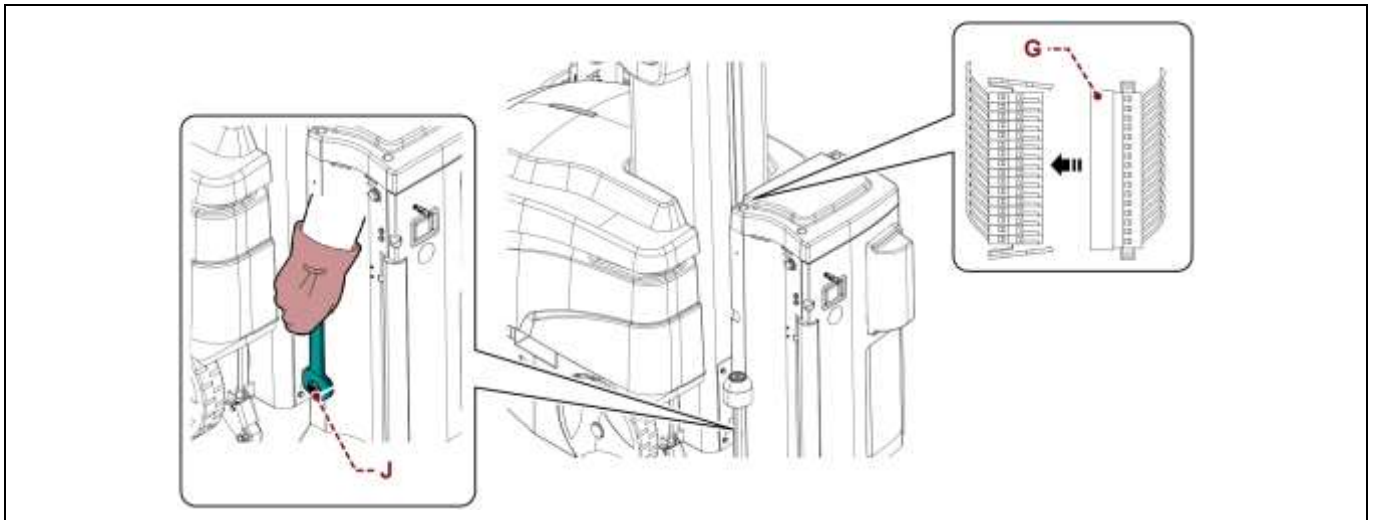

### 4.4.3. INSTALLATION OF FEELER AND RUDDER

Proceed as follows.

1. Lift the rudder (A) and extract it from the machine.

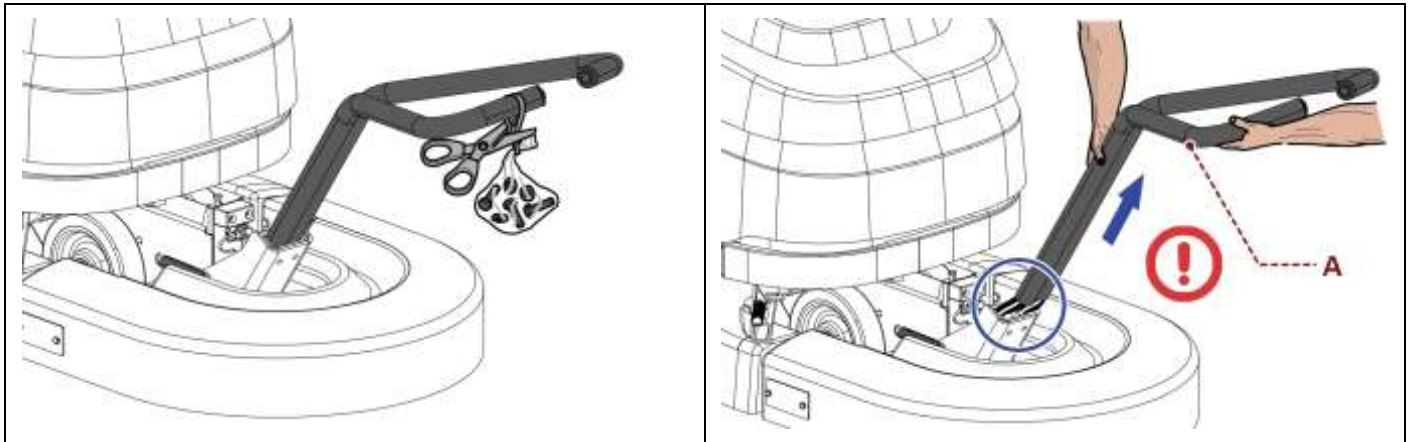

2. Turn the rudder (A), connect the connectors (B) and insert it into the machine's support.
3. Lift the rudder (A) and fasten it with the screws (C).

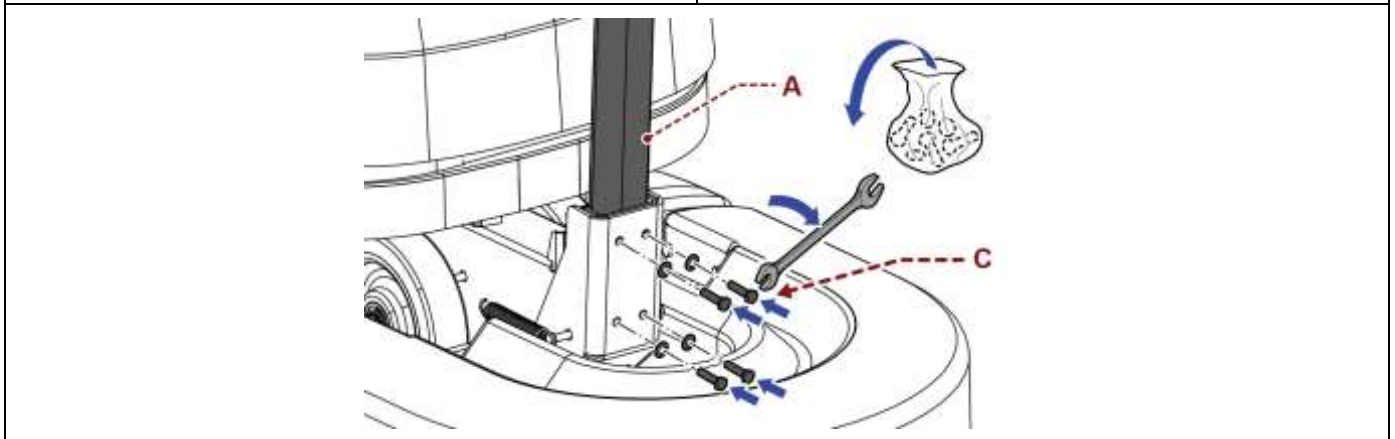
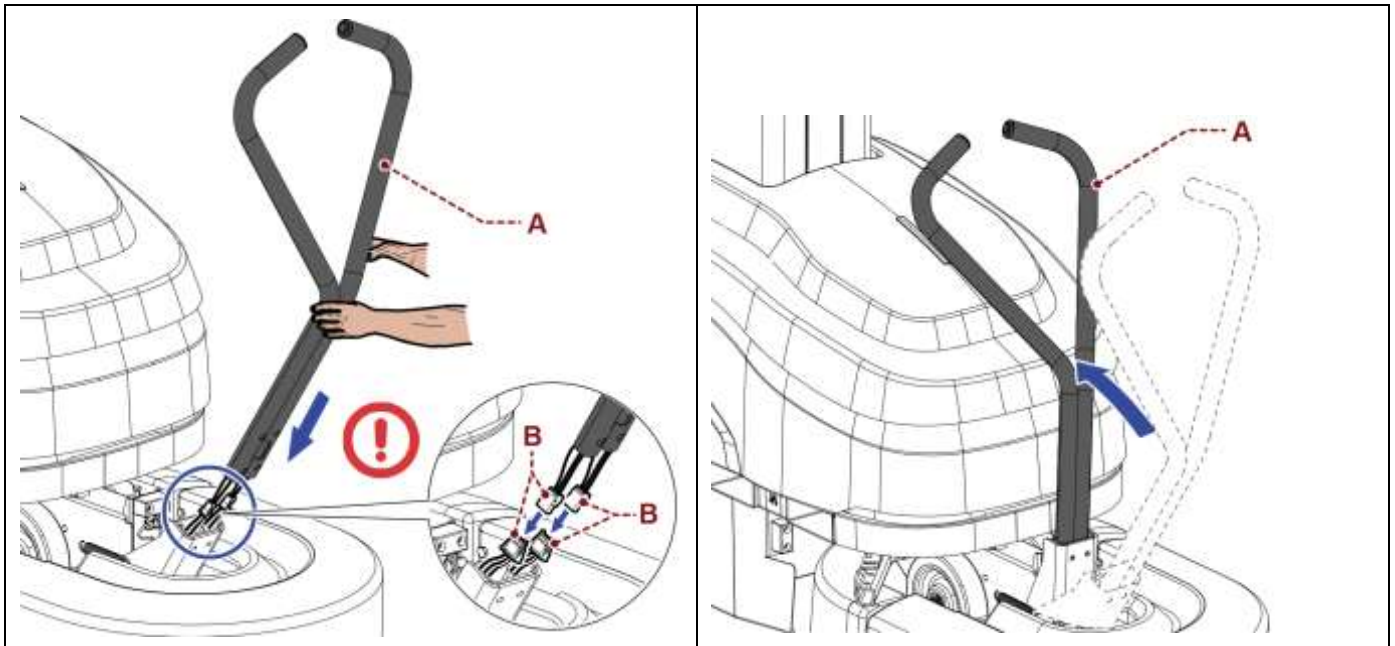

4. Fit the feeler (D) and fasten it with the screws (E).



**Important**

To fit the rudder and the feeler use the bolts supplied with the machine.

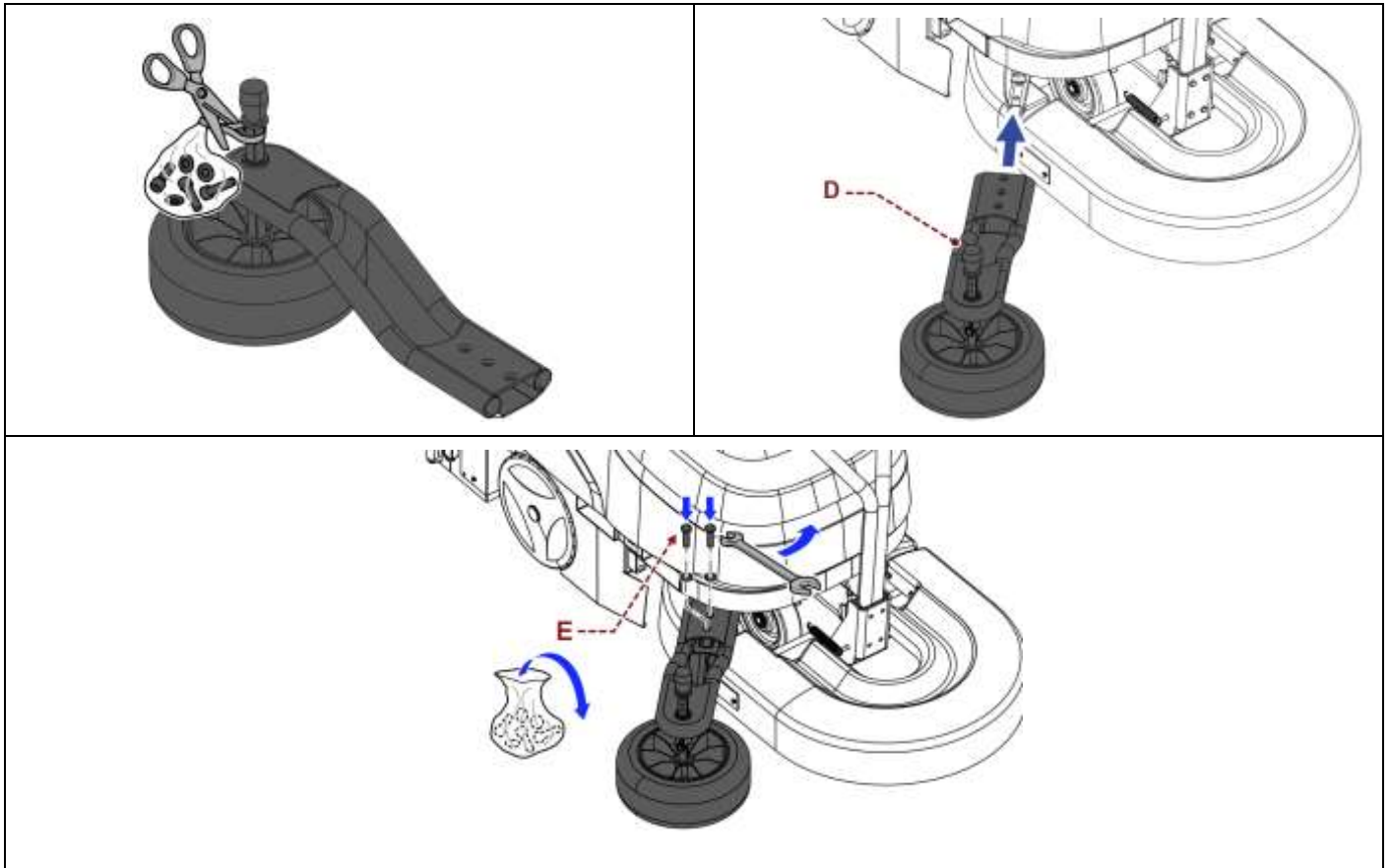

#### 4.4.4. UPPER COVER INSTALLATION

Proceed as follows.

1. Take the upper cover (A).
2. Put the cover on the casing (B) and connect the connector.
3. Place it on top of the casing and slide it towards the sliding shaft until engaging the casing tabs.



**Caution - warning**

Make sure that the tabs are clicked in because, when opening the entire casing, if the cover is not secured there is a danger of it falling off.

4. Open the casing and tighten the two safety screws (C).

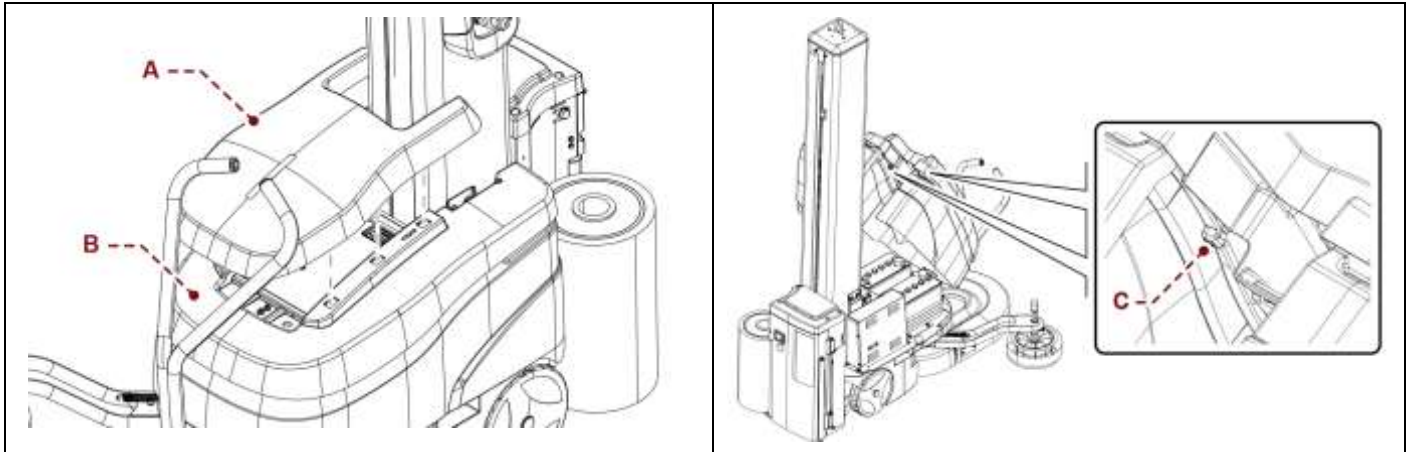

## 5. INFORMATION ON ADJUSTMENTS

### 5.1. RECOMMENDATIONS FOR ADJUSTMENTS

- Before performing any operation, the authorised operator must make sure to have understood the "Instructions for use".
- Activate one of the safety devices provided, stop the machine and assess whether there is any residual energy before carrying out the operations.
- Provide suitable safety conditions in compliance with the regulations on workplace safety to prevent and minimise the risks.
- Pay attention to the safety warnings, do not misuse the machine and assess the possible residual risks.

### 5.2. "FILM STRETCH" ADJUSTMENT

#### 5.2.1. "FRD for mesh" TYPE REEL CARRIAGES

Proceed as follows.

1. Work on the handwheel (A) until reaching the value displayed on the index (B).

The brake shaft for mesh is an accessory that can be mounted on the carriage at a later stage. This optional fitting allows the system to use a mesh reel with a std "FRD" carriage.



#### Important

For a correct tensioning of the mesh, adjust the braking effect so that the outfeed roller (C) is more braked than the infeed roller (D); moreover, it is necessary to avoid braking the stretching rollers too much to prevent the mesh from slipping.

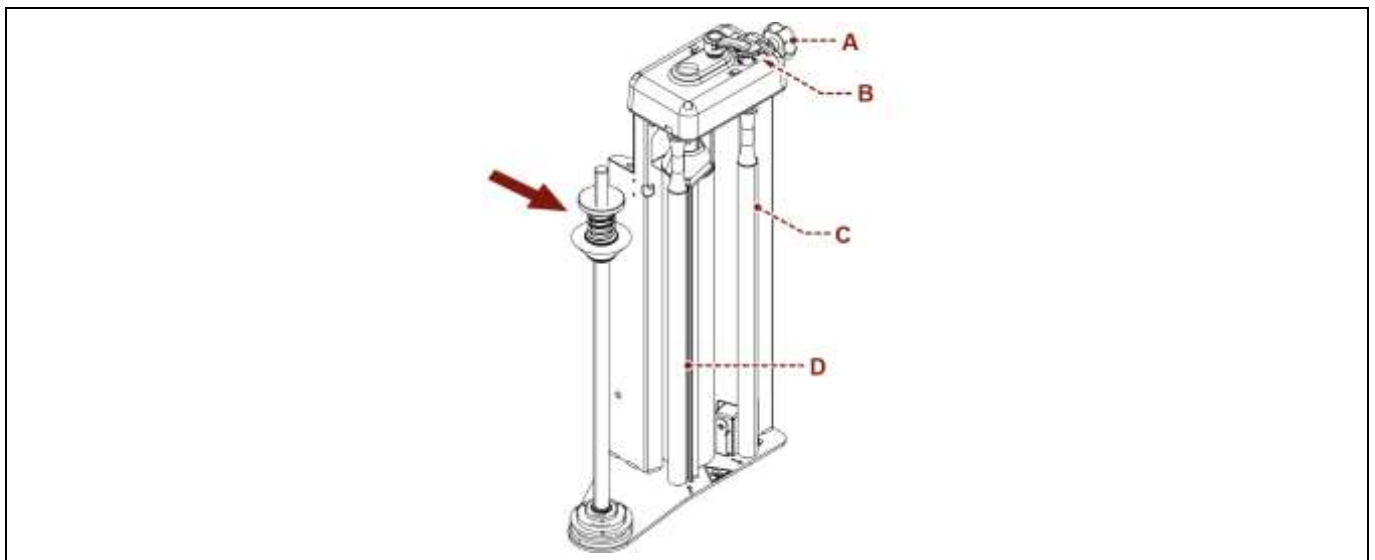

### 5.2.2. "P3GS" REEL CARRIAGES FOR CHANGING PRE-STRETCH RATIOS

Proceed as follows.

1. Open the door (A).
2. Lift switch (B) until reaching the requested value (250/0/150 – 300/0/230).



**Important**

To select a higher pre-stretch, place the selector all the way down; to set a lower pre-stretch, place the selector all the way up.

Set the selector in the centre to have a pre-stretch of 0.

3. Close the door (A).



**Important**

The correct value is the one at the bottom

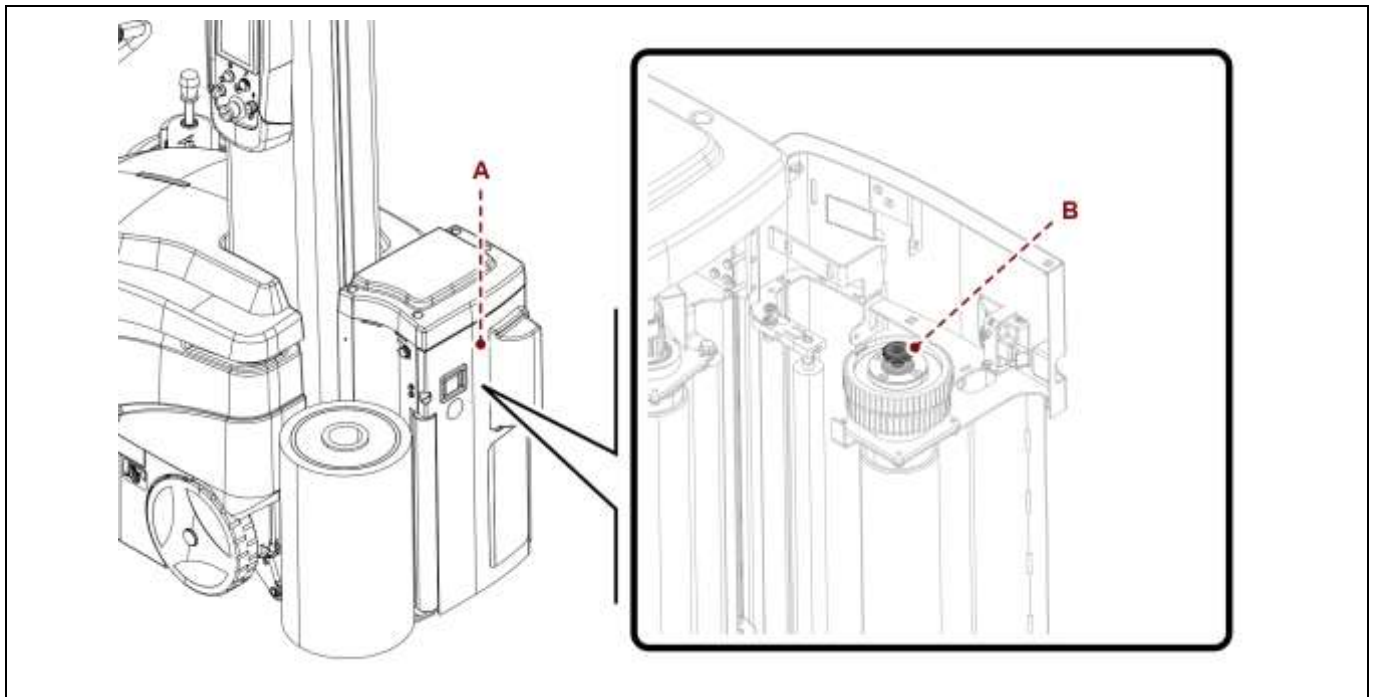

### 5.3. SPOOL CARRIAGE LIFTING CHAIN ADJUSTMENT

Proceed as follows.

1. Lift the reel carriage (with the machine operating in “manual mode”) until it reaches the “upper” limit switch.
2. Turn the machine off (refer to paragraph “machine safe stop”).
3. Use any means to prevent possible falls from the carriage (e.g. forklift truck).



#### Important

Reel carriages, complete with reel, can weigh up to 90kg.

4. Remove the guard (A).
5. Loosen the nuts (B).
6. Tighten “M8x50 UNI 5739” screw (C) on the chain tensioner (D) to a tightening torque of 3 Nm.  
The screw and the torque wrench are not supplied.
7. Screw the nuts (B) again until reaching the chain tensioner (D) level.
8. Remove screw (C).
9. Refit the guard (A).

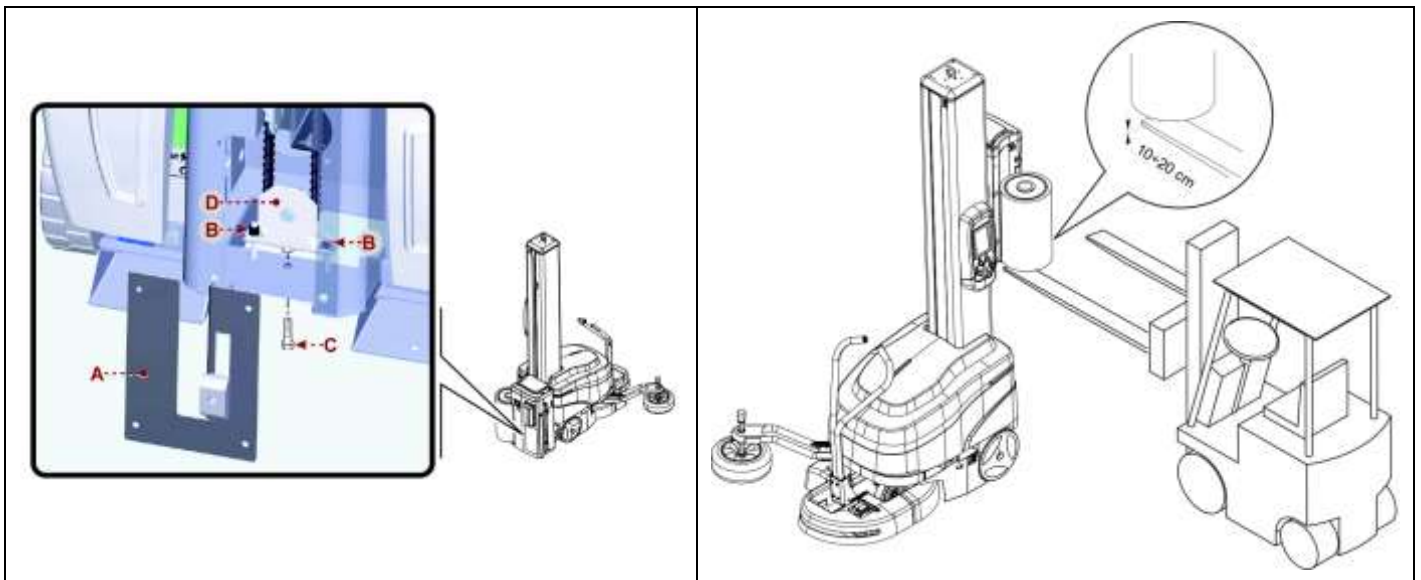

## 5.4. STEERING WHEEL RETURN SPEED ADJUSTMENT

Proceed as follows.

1. Perform "machine safe stop".
2. Work on screw (A) to adjust the rudder retraction speed.



### Important

The directional rudder retraction speed must not be too high in order to prevent any risk for human safety.

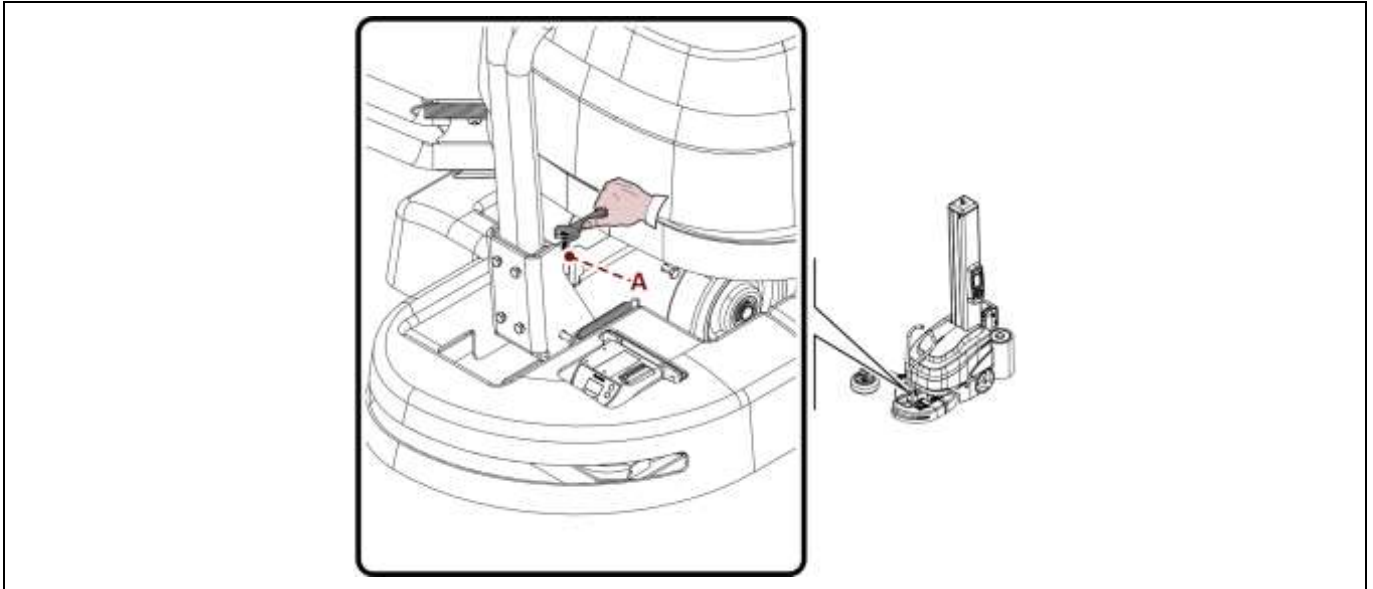

## 5.5. ADJUSTING THE HEIGHT OF THE FEELER WHEEL

Proceed as follows.

1. Perform "machine safe stop".
2. Pull the knob (A), adjust the height of the wheel (C) using the knob (B) and release the knob (A) so that the pin is correctly inserted into one of the holes.
3. To obtain greater heights, remove the knob (B), loosen the nut from the wheel (C) and refit them inverting their positions.

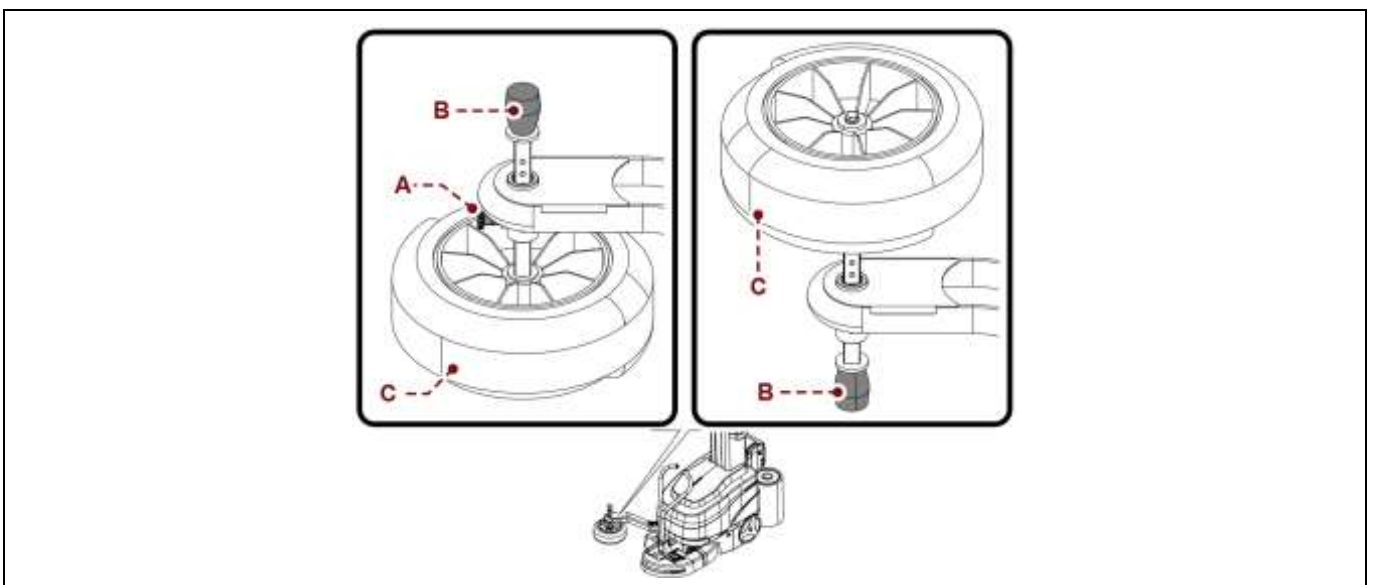

## 5.6. FEELER THRUST ADJUSTMENT

Proceed as follows.

1. Perform "machine safe stop".
2. Lower the rudder (A).
3. Lift the hood (B).
4. Grasp the lever (C).
5. Connect the lever (C) to the tensioner (D).
6. Adjust the tensioner (D) following its path.
7. Disconnect the lever (C) from the tensioner (D).
8. Put the lever (C) away.
9. Lower the hood (B).
10. Raise the rudder (A).

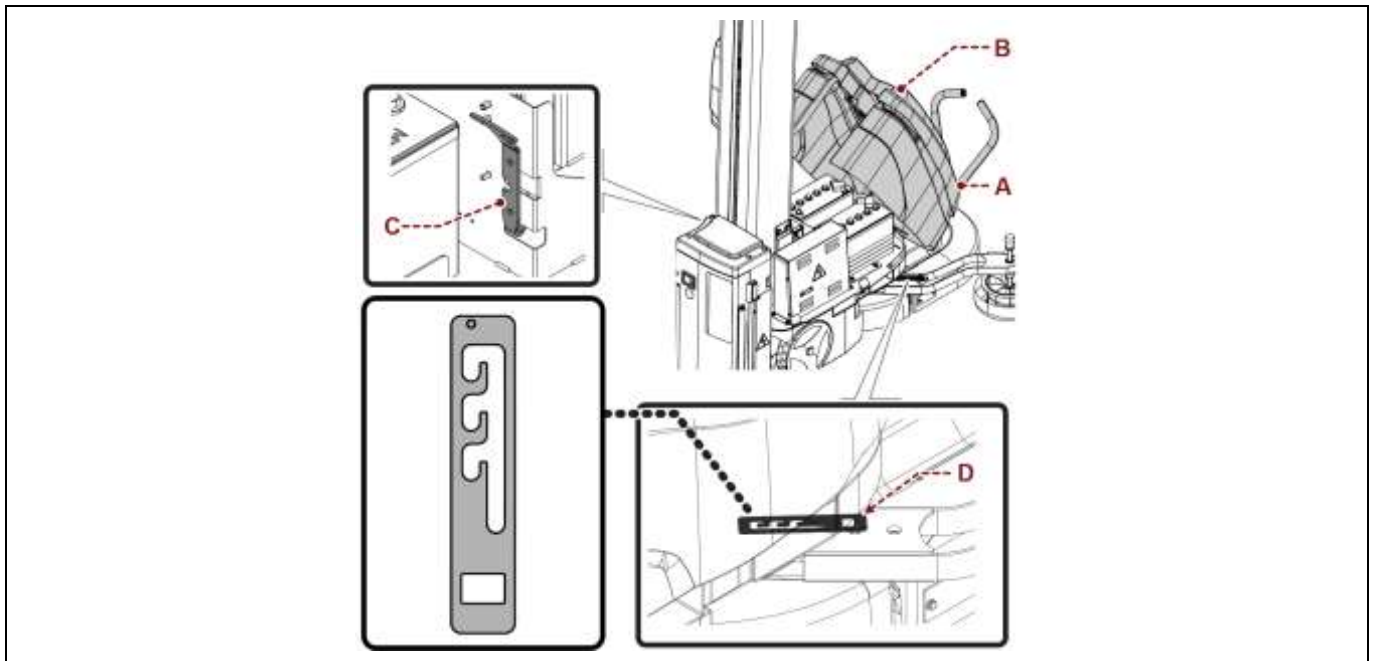

## 6. INFORMATION ABOUT THE USE

### 6.1. RECOMMENDATIONS FOR OPERATION AND USE

- When using the machine for the first time, the operator must read the manual and identify the control functions and simulate some operations, especially machine start and stop.
- Make sure that all safety devices are properly installed and efficient.
- Only carry out the operations foreseen by the Manufacturer and do not tamper with any device to obtain different performance levels.



#### **Important**

The frequency of the accidents derived from machine use depends on many factors that cannot always be foreseen and controlled.

Some accidents may be caused by unpredictable environmental factors, others are mainly due to users' behaviours.

On first use, and if required, in addition to being authorised and appropriately informed, the personnel must simulate some manoeuvres to identify the main controls and functions.

Only carry out the operations foreseen by the Manufacturer and do not tamper with any device to obtain different performance levels.

Make sure the safety devices are properly installed and efficient before use.

Users, besides complying with these requirements, must apply all the safety regulations and carefully read the descriptions of the controls and commissioning.

## 6.2. DESCRIPTION OF THE CONTROLS

The figure shows machine main controls and the list includes their description and function.

- A) **Emergency stop button:**  
it is used in case of imminent risk to stop, with a voluntary action, the machine parts which may pose a risk.  
For further details, see the paragraph "description of safety devices".
- B) **User interface:**  
it is used to set or modify the machine operating parameters.  
For more details, see the paragraph "Description of user interface".
- C) **"Cycle start" button:**  
it is used to start the wrapping automatic cycle.
- D) **Light selector switch (white light):**  
it enables and disables the power supply voltage of controls.  
When the indicator light comes on, it signals that the function has been activated, turn the selector and hold it until the light comes on.
- E) **"Reset" button:**  
it is used to reset the machine before restarting it after an emergency stop or after a shut-down due to the disconnection of the power supply.
- F) **Buttons (hold to run):**  
they are used to manually move the machine. The manual function is only enabled with the rudder in the forward position. The right button also resets the laser scanner.  
In the event of a laser scanner alarm, the right button resets the machine and in order to activate this function it is necessary to place the rudder in the forward position.
- G) **USB port:**  
it allows exchange of data.

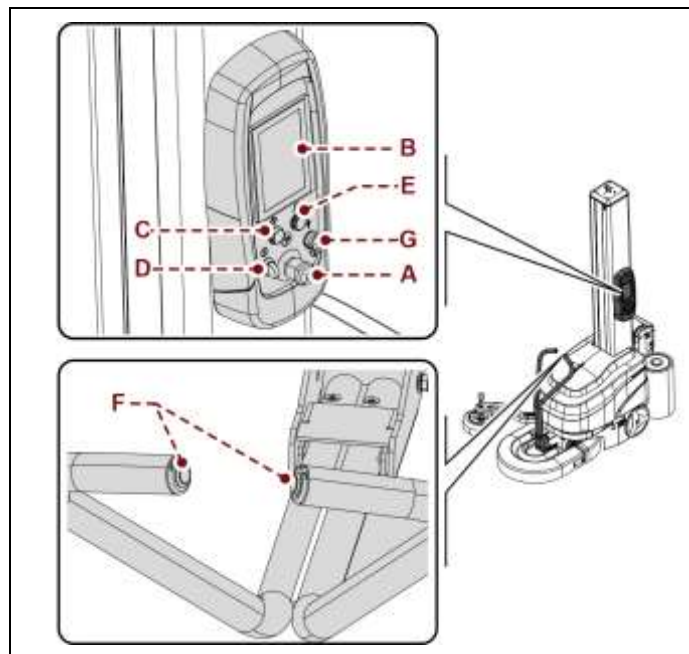

### 6.3. DESCRIPTION OF USER INTERFACE

The user interface is equipped with an active matrix “touch screen” colour display. To view the different functions, just “touch with a finger” the display areas.

The figure shows the functional logic diagram of the “navigation” modes.

There are two controls for automatic packaging cycle: STANDARD and MULTILEVEL CONTROL (from the “layer home” page).

MULTILEVEL CONTROL allows breaking down the product height in **5** different levels with adjustable thickness and, for each one of them, it is possible to adjust film stretch, pre-stretch (only on motorised carriages), reinforcement wrapping turns, machine rotation speed and carriage speed.

Each one of the **5** levels can be set with values depending on the carriage movement direction, namely also with different values for upstroke and downstroke.

No.	Name	Description of the function
1	“Home” page	The page is displayed upon the activation of the reset control. The page displays the wrapping values currently in use and grants access to the other pages.
1.1	“Layer home” page	The page is displayed upon the activation of the control on the right of the various recipes from the “recipes” page. The page displays the wrapping values currently in use and gives access to the other pages
2	“Manual handling” page.	The page displays the controls to activate the film carriage movement in “manual mode”.
3	“Recipes” page	The page displays the controls to activate the concerned recipe.
4	“Wrapping cycle” page	The page displays the controls to activate the wrapping cycle
5	“General parameters” page	The page displays the controls to program the machine set-up parameters
6	“Production counters (pallets)” page	The page displays the controls to check the quantity (partial and total) of the pallets made
7	“(H.M.I.) enabling” page	The page displays the controls to customise the user interface operating mode (only visible with “machine operator” user)
8	“Change password” page	The page displays the controls to change the password to access protected functions
9	“Enter password (user login)” page	The page displays the controls to enter the password (relating to the selected user) to access the protected functions.
10	“Manuals” page	The page displays the controls for accessing the user manual and the on-screen spare parts catalogue.

For details on the listed pages, see the description in the specific paragraph.

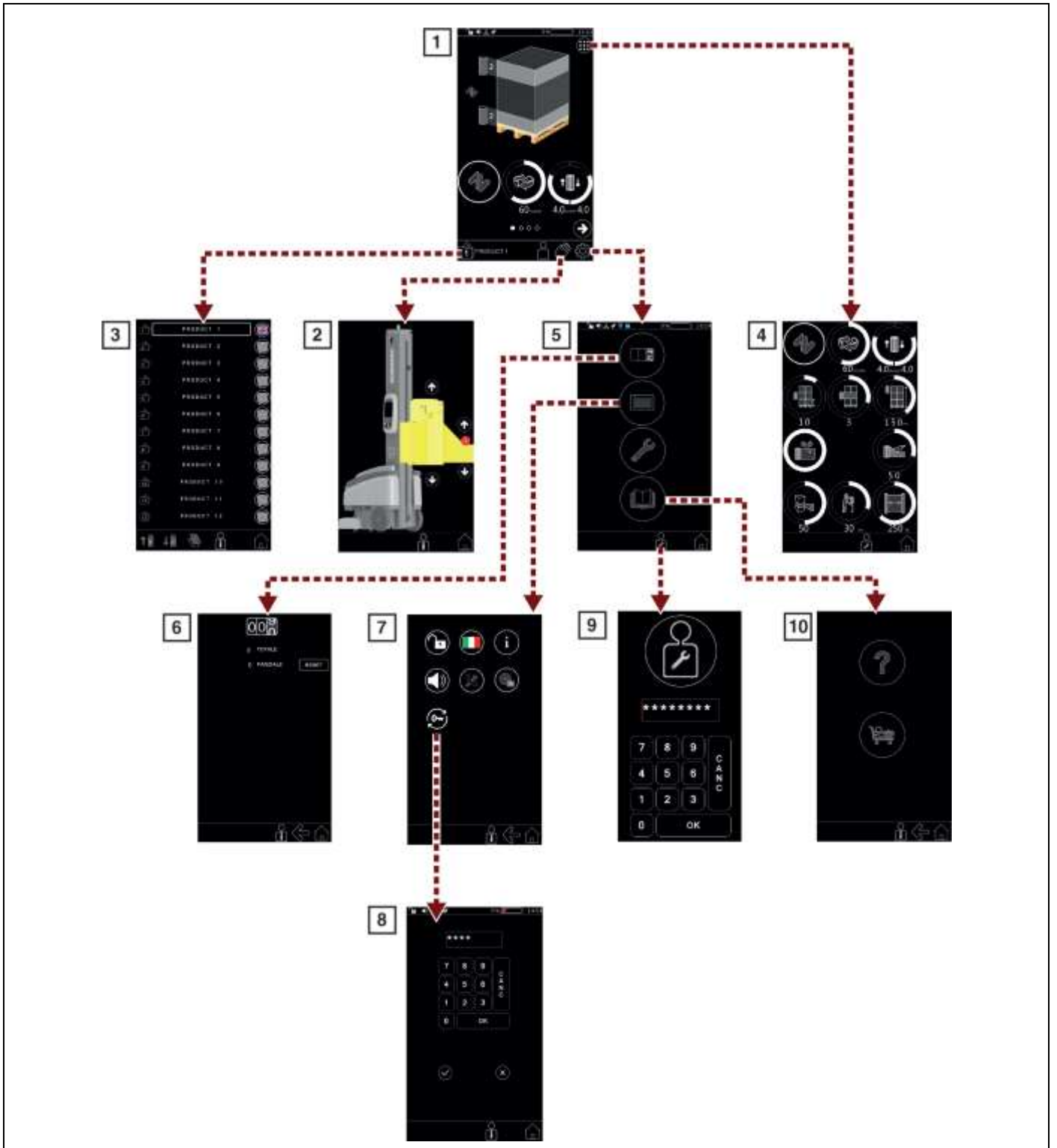

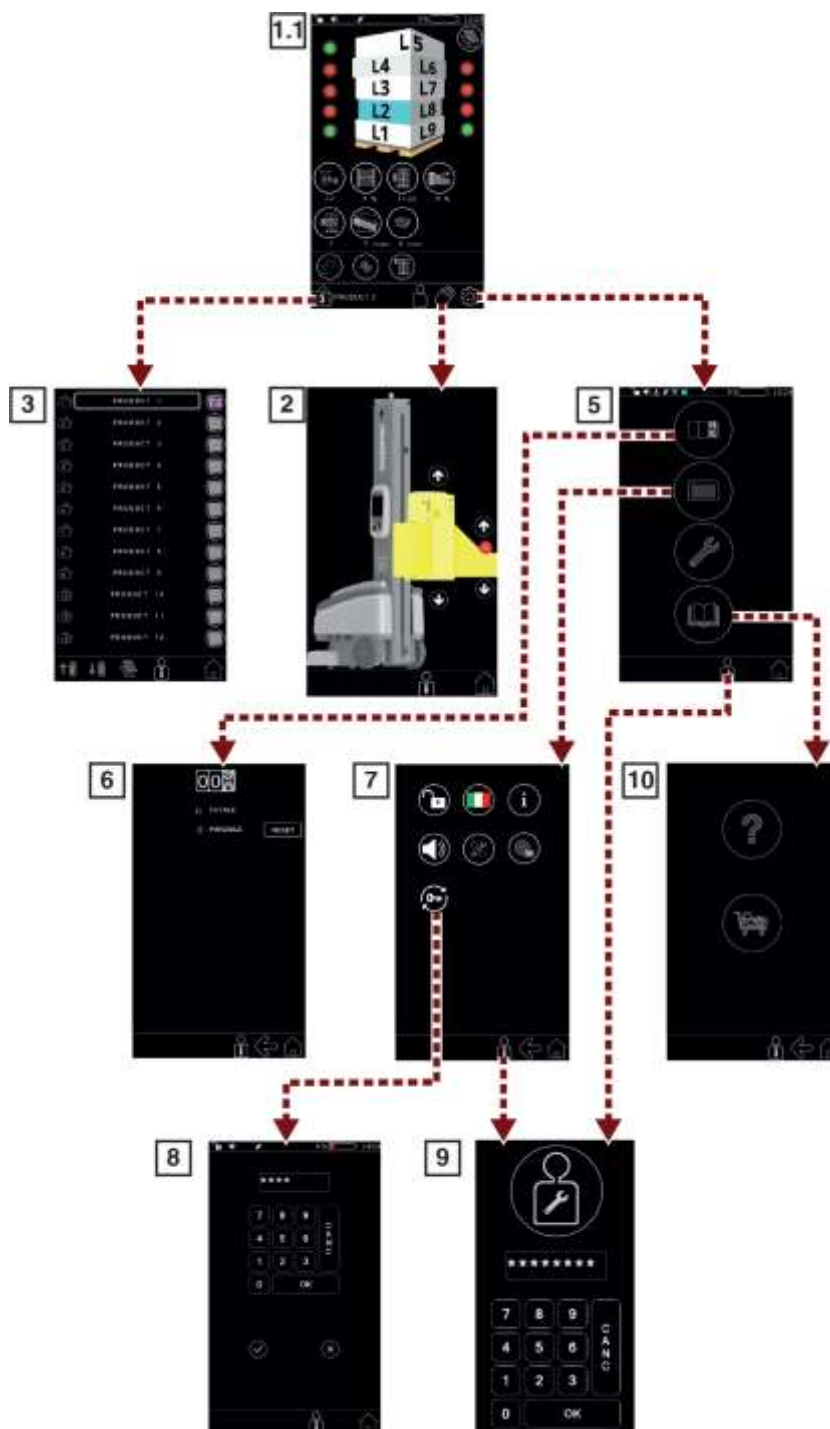

### 6.3.1. NUMERICAL AND ALPHANUMERICAL KEYBOARD

Some values, displayed in the areas of each single page, can be properly programmed. The keyboard is displayed each time that an editable or programmable area is pressed. After entering the characters (numerical or alphabetical), press the button to confirm. The new value will appear in the selected area.

No.	Name	Description of the function
A	Display area	The area displays the numerical and alphabetical characters entered
B	Button	Activating the control will close the page and the values entered will not be saved.
C	Button	Activating the control will delete the selected character
D	Button	Activating the control will delete one character at a time (starting from the last one on the right).
E	Button	Activating the control will save the value or the text entered
F	Button	Activating the control will perform the functions of the "space bar"
G	Button	Command activation performs the function of upper/lower case

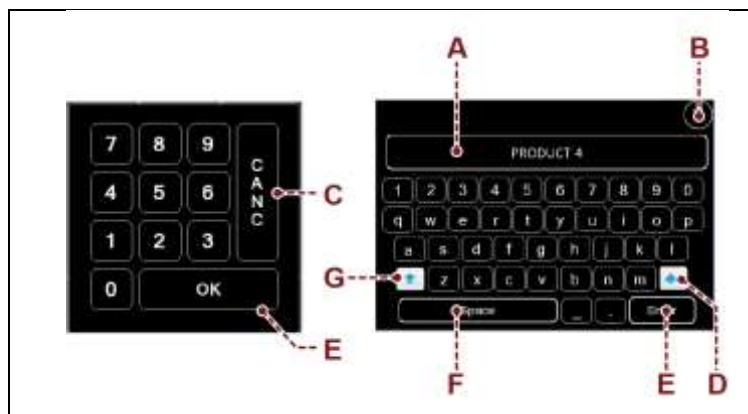

### 6.3.2. PROGRAMMING WINDOW

The window is displayed each time that an editable or programmable area is pressed.

- A) Area: it displays the icon corresponding to the concerned parameter to be programmed.  
The figure shows a typical example of window and the table includes the description of the icons.
- B) Button: it is used to close the programming window.
- C) Bar: it is used to (quickly) increase or decrease the value displayed in the area (E).
- D) Buttons: they are used to increase or decrease (one unit at a time) the value displayed in the area (E).
- E) Area: it displays the programmed parameter value.

Icon	Description of the function
1	Setting the type of wrapping cycle
2	Machine forward speed
3	Carriage upstroke / downstroke speed
4	Height from the ground at wrapping cycle start
5	Reinforcement wrappings
6	Altimeter/photocell setting
7	Cut
8	Film height adjuster – roping device.
9	Film stretch
10	Ergonomic upstroke
11	Pre-stretch value

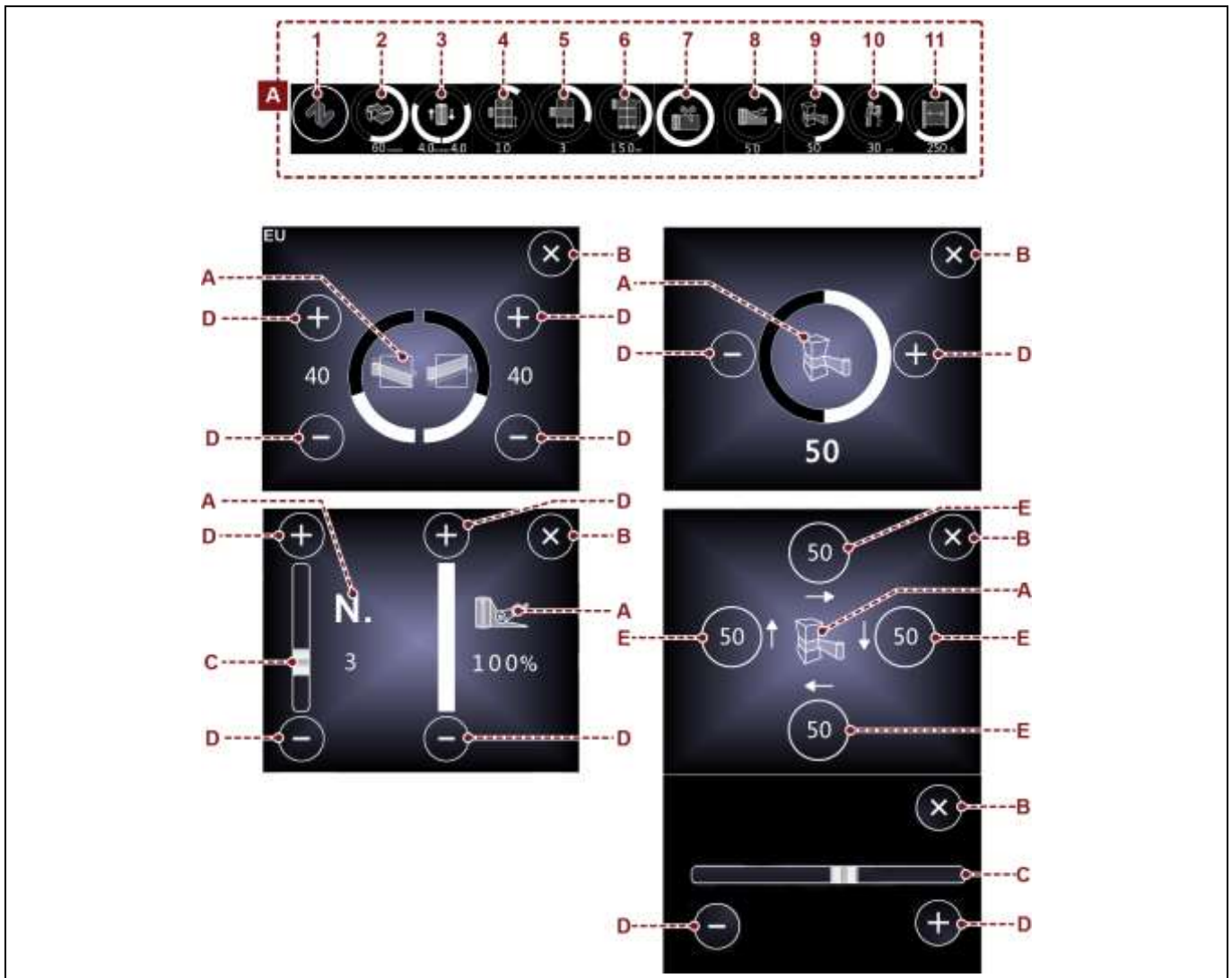

## PROGRESSIVE ADJUSTMENT OF VALUES

The percentage value of the selected parameter can be changed in steps of 25% or 50% depending on which parameter has been chosen.

To select the parameter as a percentage, correctly press on the section (A) of the circle or semicircle.

Areas are divided as follows:

- a) Press on the area to set the value to 25%.
- b) Press on the area to set the value to 50%.
- c) Press on the area to set the value to 75%.
- d) Press on the area to set the value to 100%.

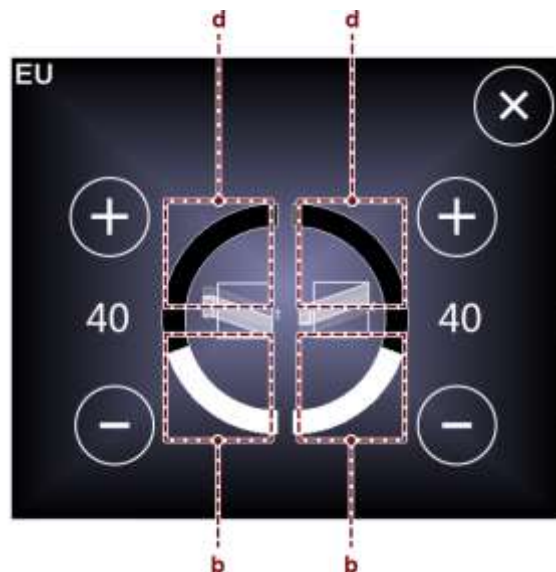
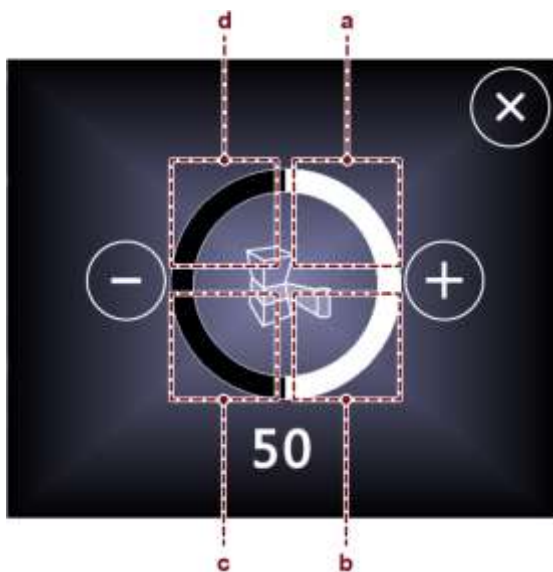
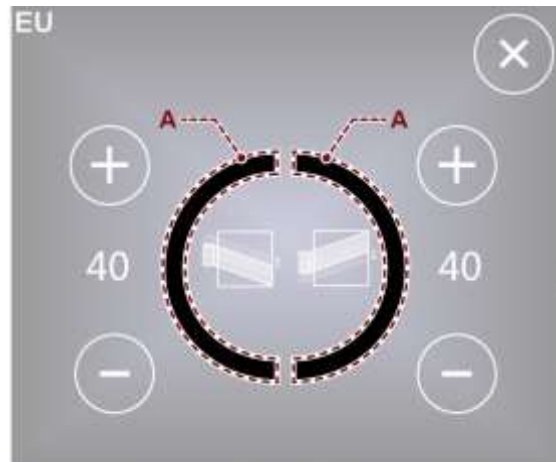
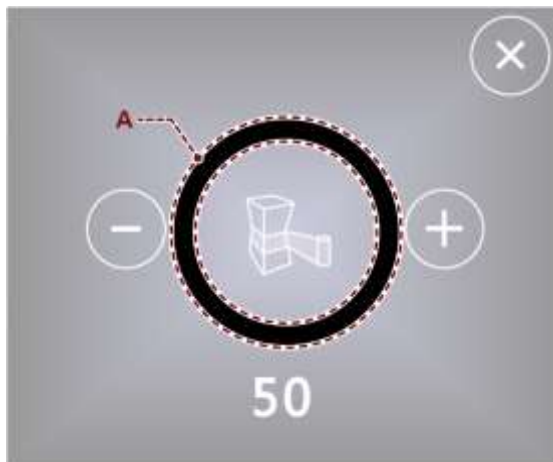

### 6.3.3. USING THE PANEL

Proceed as follows.

1. Press the button (A) to enable the power supply of controls.
2. Press the "Reset" button (B).
3. When machine is ready, the main page is displayed (C).
4. If you need to select a different function than the one already active, press the relevant icon on the touch screen.
5. Press the "START" button (D) to turn the machine on.

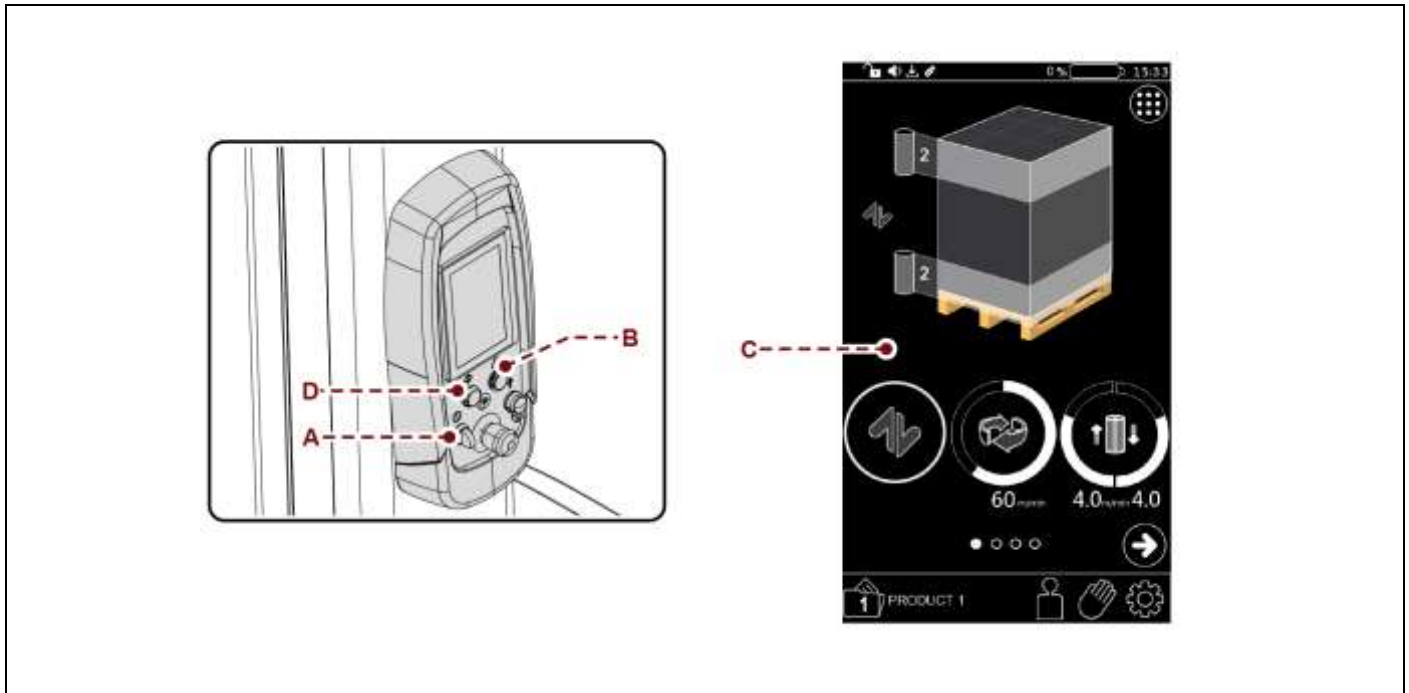

## 6.4. "HOME" PAGE

### 6.4.1. "HOME STANDARD CONTROL" PAGE

The page displays the wrapping values currently in use and gives access the other pages.

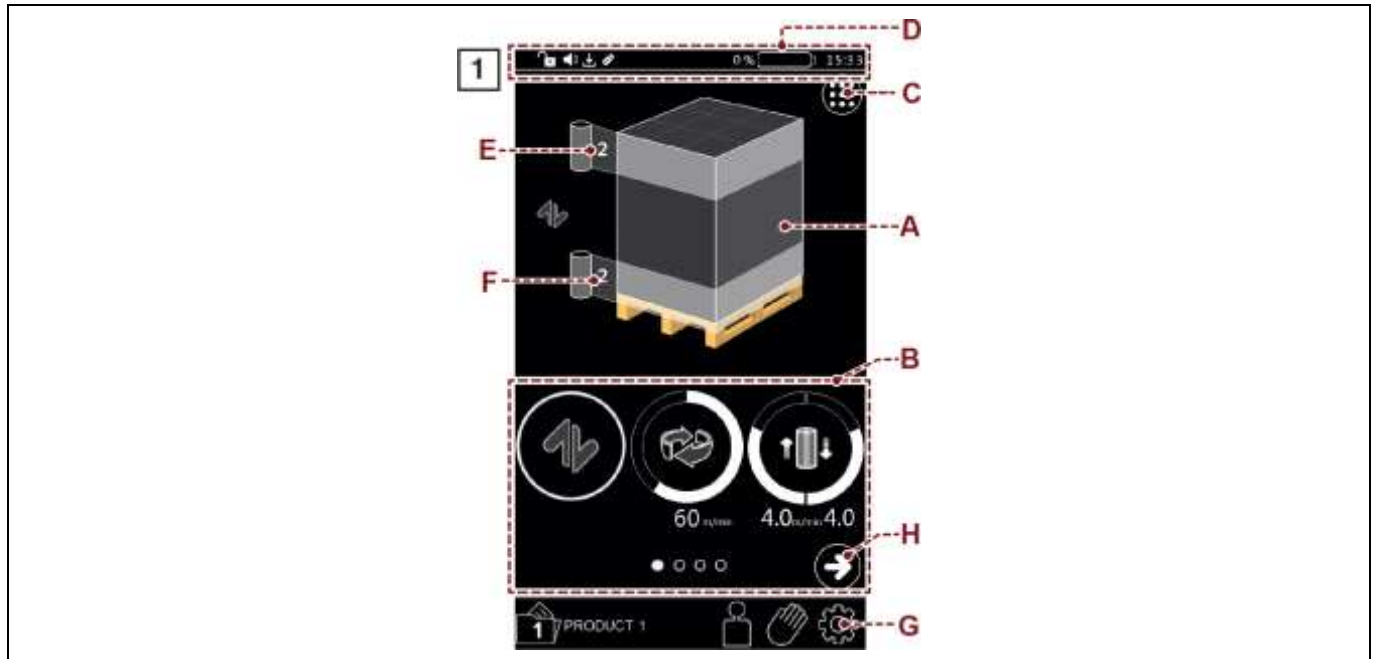

- A) Area: Previews the settings of the selected pallet wrapping cycle.
- B) Area: Displays the individual editable parameters for setting the wrapping cycle.
- C) Button: It is used to display all the parameters of the "wrapping cycle" at the same time.  
To program the wrapping cycle refer to chapter 6.8 "Wrapping Cycle Page".
- D) Area: Battery charge status indicator: indicates battery charge status.
  - Battery charge: the battery condition is signalled by means of coloured bars (green, yellow and red).
  - Battery flat: this condition is signalled with an alarm message and an acoustic warning when the battery level is below 20%.
- E) Button: used to program the quantity of reinforcing wrappings at the upper end of the pallet.  
The displayed number indicates the programmed value.
- F) Button: used to program the quantity of reinforcing wrappings in the lower area of the pallet.  
The displayed number indicates the programmed value.

**G) Area: Toolbar.**

The toolbar is displayed in every page and features only the buttons which can be activated. The list includes the description of the elements (buttons, icons, etc.) displayed in the area.

	<p>Button: used to display the "Recipes" page. Next to the recipe name.</p>
	<p>Button: used to display the "Login" page. For further details consult the paragraph "password entry page (user login)".</p>
	<p>Button: it is used to display the "Manual handling" page.</p>
	<p>Button: it is used to display the "General parameters" page.</p>
	<p>Button: it is used to display the upper level page.</p>
	<p>Button: it is used to display the "home" page.</p>

**H) Button: allows scrolling the page of editable "wrapping cycle" parameters (ref. Area B).**

**I) Area: It is used to activate/deactivate the drop-down menu.**

The menu can be activated/deactivated in all pages and shows only the buttons that can be activated. The list includes the description of the elements (buttons, icons, etc.) displayed in the area.

	<p>Button: adjusts the brightness of the screen using the (+) and (-) keys.</p>
	<p>Button: it is used to activate or deactivate the display sounds.</p>
	<p>Button: display of partial production counter (pallets). Allows resetting the machine with "machine operator" logged in</p>
	<p>Button: it is used to change energy-saving setting.          - 15' - Disabling the interface after 15 minutes of inactivity          - 30' - Disabling the interface after 30 minutes of inactivity</p>



**Important**

The partial (pallet) production counter can be viewed only with the machine with lithium batteries.

### 6.4.2. "HOME MULTILEVEL CONTROL" PAGE

The page displays the wrapping values currently in use and gives access the other pages.

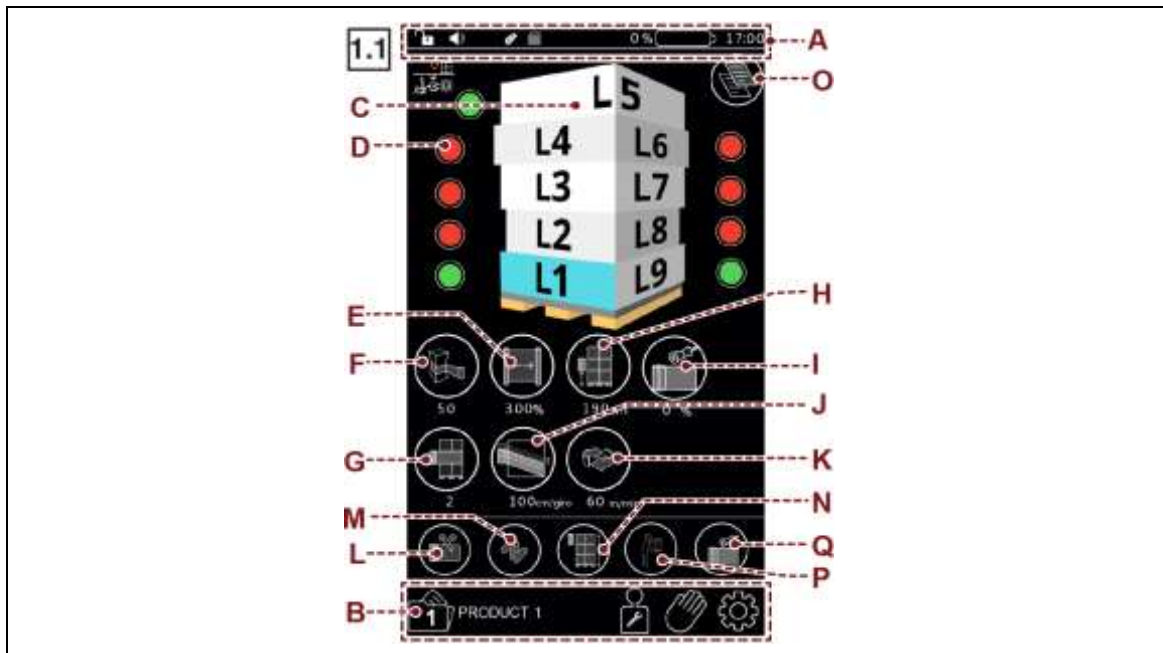

**A)** Area: this is used to activate/deactivate the drop-down menu (described in par. "Home standard control page" letter "1").

The menu can be activated/deactivated in all pages and shows only the buttons that can be activated.

**B)** Area: Toolbar. (described in par. "Home standard control page" letter "G")

The toolbar is displayed in every page and features only the buttons which can be activated.

**C)** Area: allows selecting the level of which you want to set/modify the wrapping parameters.

**D)** Button: used to enable/disable the level

- Red: level disabled.
- Green: level enabled.

For the description of the buttons E, F, G, H, I, J, K, L, M, N, O see chapter "Wrapping cycles".

**E)** Button: it is used to set the film pre-stretch value.

The displayed number indicates the programmed value. Present in carriage PVS only.

**F)** Button: it is used to set the film stretch value.

The displayed number indicates the programmed value.

**G)** Button: it is used to set the number of reinforcement wrappings.

The displayed number indicates the programmed value.

**H)** Button: it is used to set the starting height from the ground of the wrapping cycle.

The displayed number indicates the programmed value.

**I)** Button: it is used to adjust the settings of the film height reduction roping device.

Present only if the machine is equipped with the optional.

**J)** Button: it is used to adjust the upstroke of the carriage.

The displayed number indicates the programmed value.

**K)** Button: it is used to set the rotation speed value of the machine

The displayed number indicates the programmed value.

**L)** Button: it is used to activate the film automatic cutting type.

Present only if the machine is equipped with the optional.

**M)** Button: it is used to select the type of pallet wrapping cycle.

**N)** Button: it is used to select the stop mode of film carriage during upstroke.

**O)** Button: used to copy the data of one layer onto another. See paragraph "Copy level page".

**P)** Button: it is used to set the ergonomic upstroke of the carriage

**Q)** Selector button: it is used to set the roping mode

## 6.5. "MANUAL HANDLING" PAGE

The page displays the controls to activate the film carriage vertical movement in "manual mode".

- A) Button (hold to run): it is used to activate the carriage upstroke.
- B) Button (hold to run): it is used to activate the carriage downstroke.
- C) Button (hold to run): it is used to activate the roping device upstroke.
- D) Button (hold to run): it is used to activate the roping device downstroke.
- E) It is used to display the "home" page.

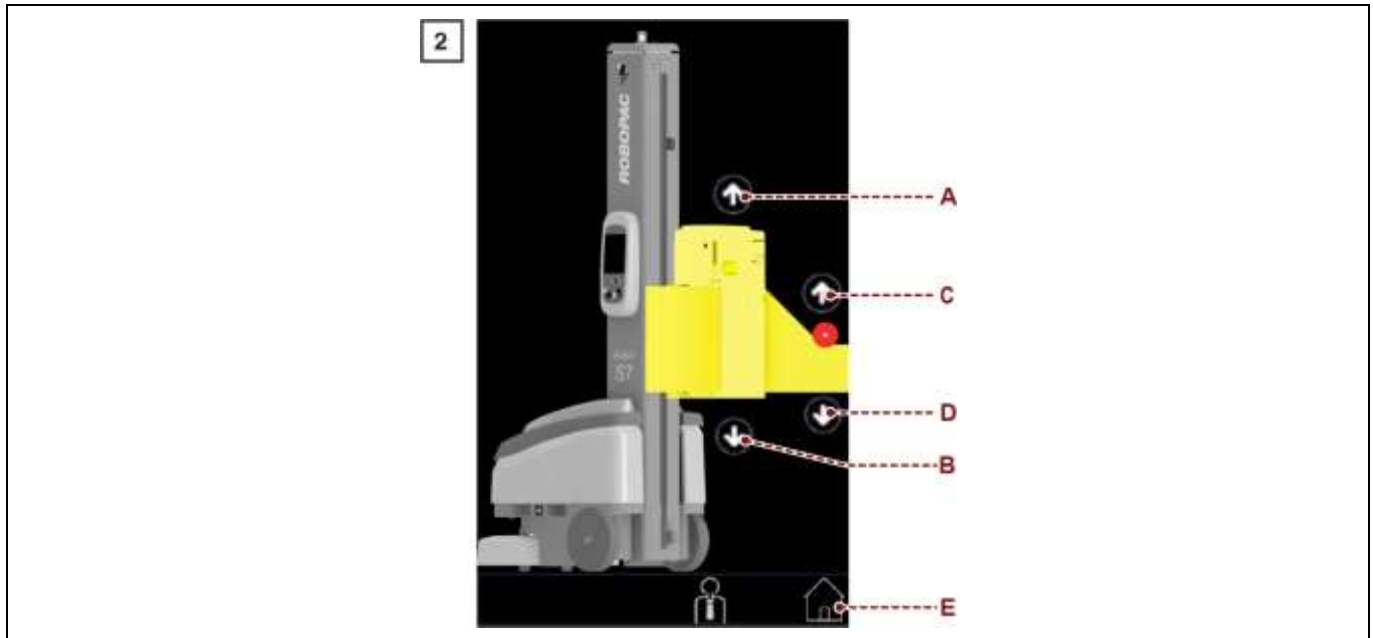

## 6.6. "RECIPES" PAGE

The page displays the controls to activate the concerned recipe.

- A) Buttons: they are used to activate the concerned recipe.
- B) Recipe name: by pressing it, you can change the name of the recipe.
- C) Buttons: if a USB key is plugged in, these are used to import or export recipe data.
- D) Button: press it to access the "copy recipes" page.
- E) Button: it is used to enable/disable the "multilevel control" for each individual recipe.

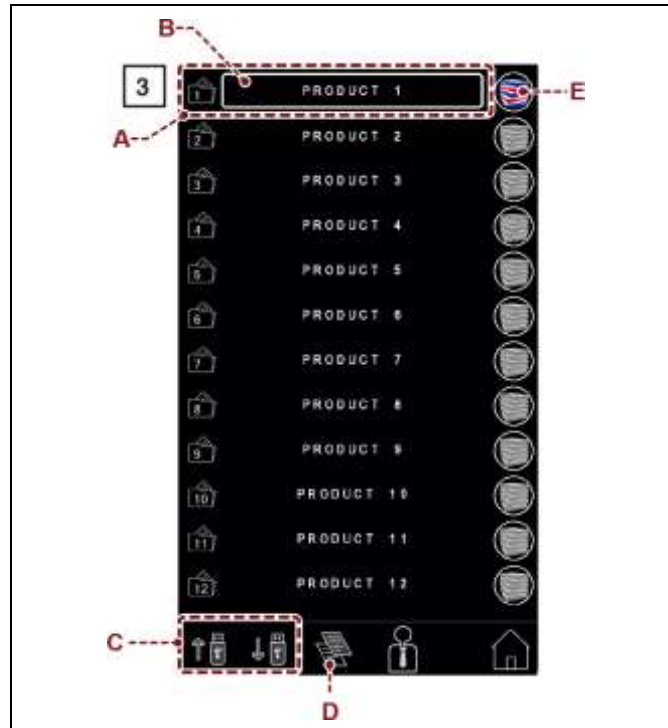

### 6.6.1. "COPY RECIPE" PAGE

- A) Button: press +/- to change the starting recipe.
- B) Button: press to confirm the operation (Enter).
- C) Button: used to go back to the "RECIPES" page.

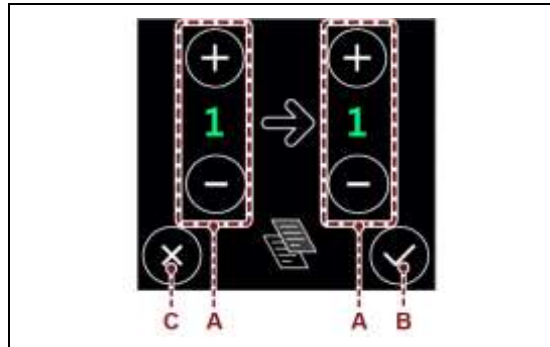

### 6.6.2. "COPY LEVEL" PAGE

To copy and move the parameters from one level to another, use the following buttons:

- A) Button: press +/- to change the starting level and destination.
- B) Button: press to confirm the operation (Enter).
- C) Button: used to go back to the "home" page.

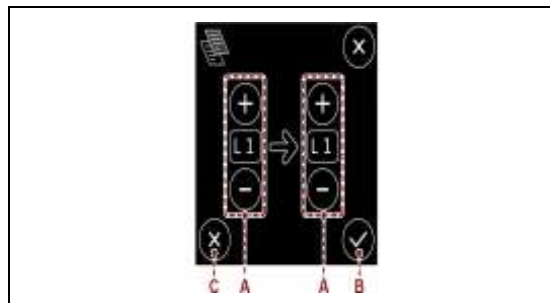

### 6.6.3. "DATA TRANSFER" PAGE

To transfer or update the parameters of a certain "work recipe", it is necessary to:

- Insert the portable mass storage in the USB port (A).
- In the bar of the "RECIPES" page, the buttons (B) and (C) will appear.
- Pressing the key (B), the page "UPLOAD RECIPES" is enabled.
- By pressing the key (D), all the "Work recipes" displayed are copied in the mass storage, inserted in the USB port (A).
- Pressing the key (C), the page "DOWNLOAD RECIPES" is enabled.
- By pressing the key (E), the starting "Recipe", selected in the mass storage, is transferred in the destination "Recipe" of the machine.



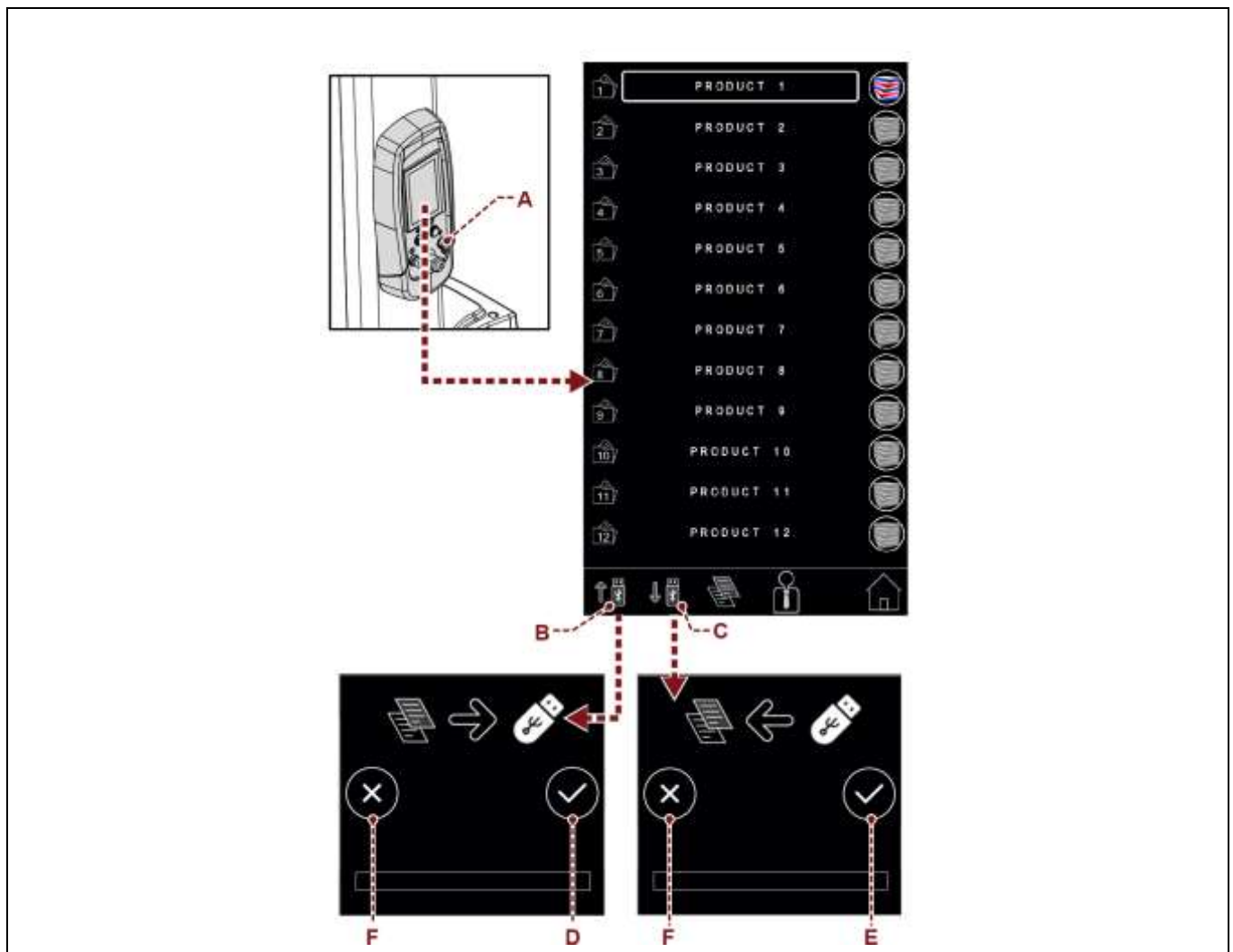

















F) Button: it is used to cancel the operation









## 6.7. "WRAPPING CYCLE" PAGE

The page displays the controls to program the wrapping cycle.

At every activation, the button displays the enabled function with the reference icon.

	<p>A) Area: it displays the name of the recipe being programmed.</p>
	<p>B) Area: it displays the preview of the selected pallet wrapping cycle.</p>
     	<p>C) Button: it is used to select the type of pallet wrapping cycle. At every activation, the button displays the enabled function with the reference icon.</p> <ul style="list-style-type: none"> <li>- Icon (C1): it is used to select the "Single wrapping" cycle.</li> <li>- Icon (C2): it is used to select the "Double wrapping" cycle.</li> <li>- Icon (C3): it used to select the "Double wrapping cycle with feeder".</li> </ul>
	<p>D) Button: it is used to set the rotation speed of the machine.</p>
   	<p>E) Selector button: it is used to set the upstroke and downstroke speed of the carriage. Press and hold the button to switch to the "Carriage upstroke in one turn" mode.</p> <ul style="list-style-type: none"> <li>- Icon (E1): it is used to adjust the speed of the carriage.</li> <li>- Icon (E2): it is used to adjust the upstroke of the carriage moving at each turn of the packaging.</li> </ul>
	<p>F) Button: it is used to enable and disable the programming of the distance from the ground (offset) at the beginning of wrapping.</p>
	<p>G) Button: it is used to program the positioning value and the number of reinforcing wrappings.</p>
   	<p>H) Selector button: it is used to select the stop mode (automatic or programmed) of film carriage during upstroke. At every activation, the button displays the enabled function with the reference icon.</p> <ul style="list-style-type: none"> <li>- Icon (H1): Automatic stop using photocell and setting of the relative delay for reading the height of the pallet</li> <li>- Icon (H2): Programmed stop by means of altimeter and setting of the relative maximum desired wrapping height.</li> </ul>
	<p>I) Button: used to enable/disable the cutting. Only if cutting is present.</p>

  	<p><b>J)</b> Selector button: it is used to set the roping mode, the required rope size and the number of performed turns. Keep the button pressed to switch from “roping from the top” to “roping from the bottom”.</p> <ul style="list-style-type: none"> <li>– Icon (<b>J1</b>): it indicates roping from the top.</li> <li>– Icon (<b>J2</b>): it indicates roping from the bottom.</li> </ul>
	<p><b>K)</b> Button: it is used to set the film stretch value</p>
	<p><b>L)</b> Button: Allows to set the ergonomic upstroke of the carriage</p>
	<p><b>M)</b> Button: Allows to set the film pre-stretch value Present only in the PVS carriage</p>

## 6.8. "GENERAL PARAMETERS" PAGE

The page is used to program the machine operating parameters.

- A) Button: it is used to display the "production counters (pallets)" page.
- B) Button: it is used to display the "H.M.I. settings" page.
- C) Button: it is used to display the "service" page.
- D) Button: used to display the "manuals" page.

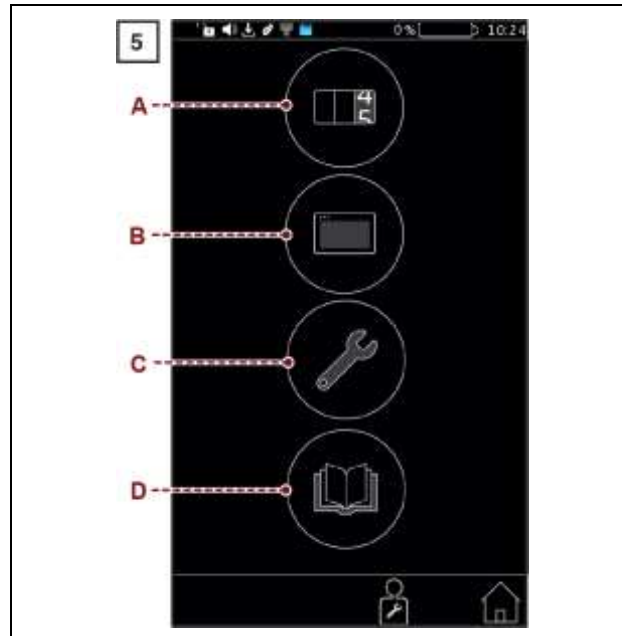

## 6.9. "PRODUCTION COUNTERS (PALLETES)" PAGE

The page displays the controls to check the quantity (partial and total) of the pallets made.

- A)** Area: it displays the counter (total) of the wrapping cycles performed by the machine.
- B)** Area: it displays the counter (partial) of the wrapping cycles performed by the machine.
- C)** Button: it is used to reset counter (**B**).

The function is active only if the system is accessed by a "machine operator" user (see the "enter password page (user login)").

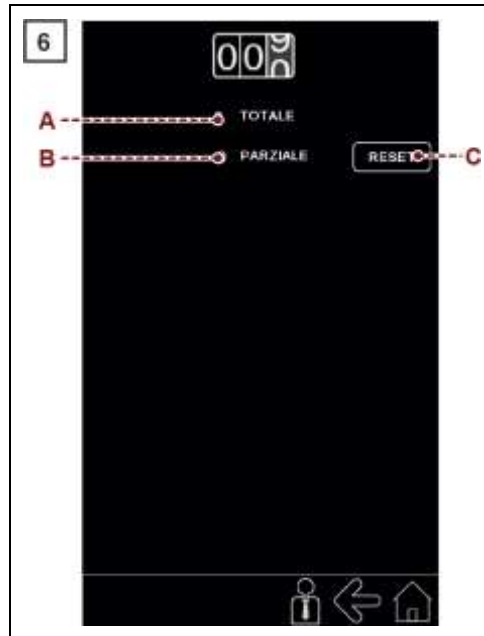

## 6.10. "HMI SETTINGS" PAGE

The page displays the controls to customise the user interface operating mode.

- A) Button: it is used to enable and disable the display acoustic signal.
- B) Button: it is used to display the "change password" page .  
The function is active only if the system is accessed by a "machine operator" user (see the "enter password page (user login)").
- C) Button: it is used to enable and disable the recipe programming mode.  
The function is active only if the system is accessed by a "machine operator" user (see the "enter password page (user login)").
- D) Button: it is used to display the page with the software version.
- E) Button: it is used to select the language.
- F) Button: it is used to display the page for setting date and time.
- G) Button: it is used to display the telephone number of the dealer to contact in case technical assistance is required.

The dealer's telephone number can be modified only when accessing the system in "assistance service" mode.

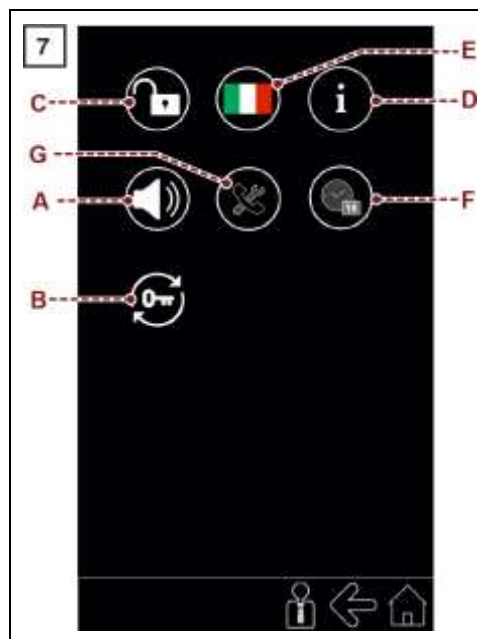

### 6.11. "PASSWORD CHANGE" SCREEN

The page displays the controls to change the password to access protected functions.

- A) Button: it is used to display the "home" page.
- B) Area: it displays the entered characters.
- C) Numerical keyboard.
- D) Button: it is used to confirm the entered values.
- E) Button: it is used to save the password.  
The activation of the control is signalled by the page (G) activation.
- F) Button: it is used to reset the entered values.
- G) Page: displays the new chosen password.
- H) Button: it is used to save the password.
- I) Button: it is used to reset the entered values.

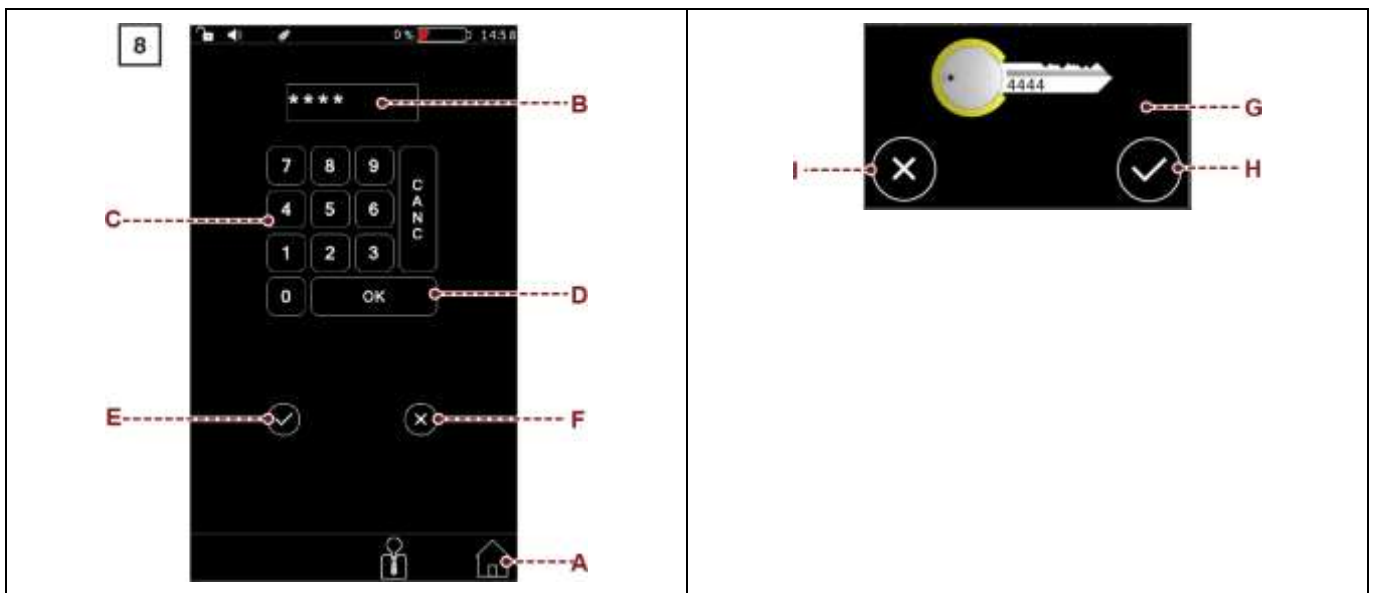

## 6.12. "ENTER PASSWORD" SCREEN (USER LOGIN)

The page displays the controls to enter the password (relating to the selected user) to access the protected functions.

- A) Button: it is used to select the type of user concerned.  
At every activation, the button displays the enabled function with the reference icon.

	Icon (A1): it is used to select the "machine user".
	Icon (A2): it is used to select the "machine operator" user.
	Icon (A3): it is used to select the "service support" user.

- B) Area: it displays the entered characters.  
C) Numerical keyboard.  
D) Button: it is used to confirm the entered password (login).  
To prevent another type of user from accessing the protected functions, use one of the following procedure to perform the "user logout" at the end of the operations.
- Touch the icon (A1) located in the toolbar.
  - Switch the machine off and then on again.
- E) Button: it is used to delete incorrect entered values.

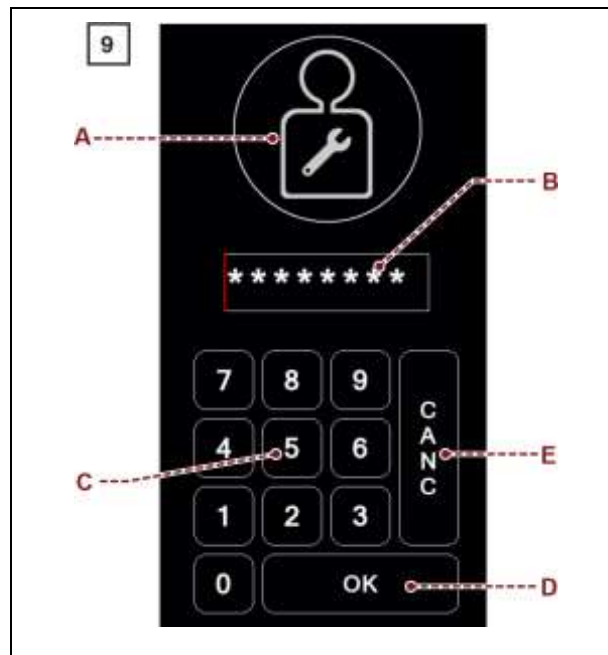

### 6.13. "SERVICE" SCREEN

The page is reserved to the Manufacturer's Assistance Service only, to perform diagnostics and basic programming. It can only be accessed using a password provided by the service department.

### 6.14. NEW RECIPE PROGRAMMING

Proceed as follows.

1. Display the "home" page 1.
2. Press the button (A) to display the "recipes" 3 page.
3. Select the concerned recipe.
4. Set the recipe name.
5. Press the button (B) to display the "home" page 1.
6. Press the button (C) to display the "wrapping cycle" page 4 or select in zone (D) the parameters to be set.
7. Set the recipe parameters.

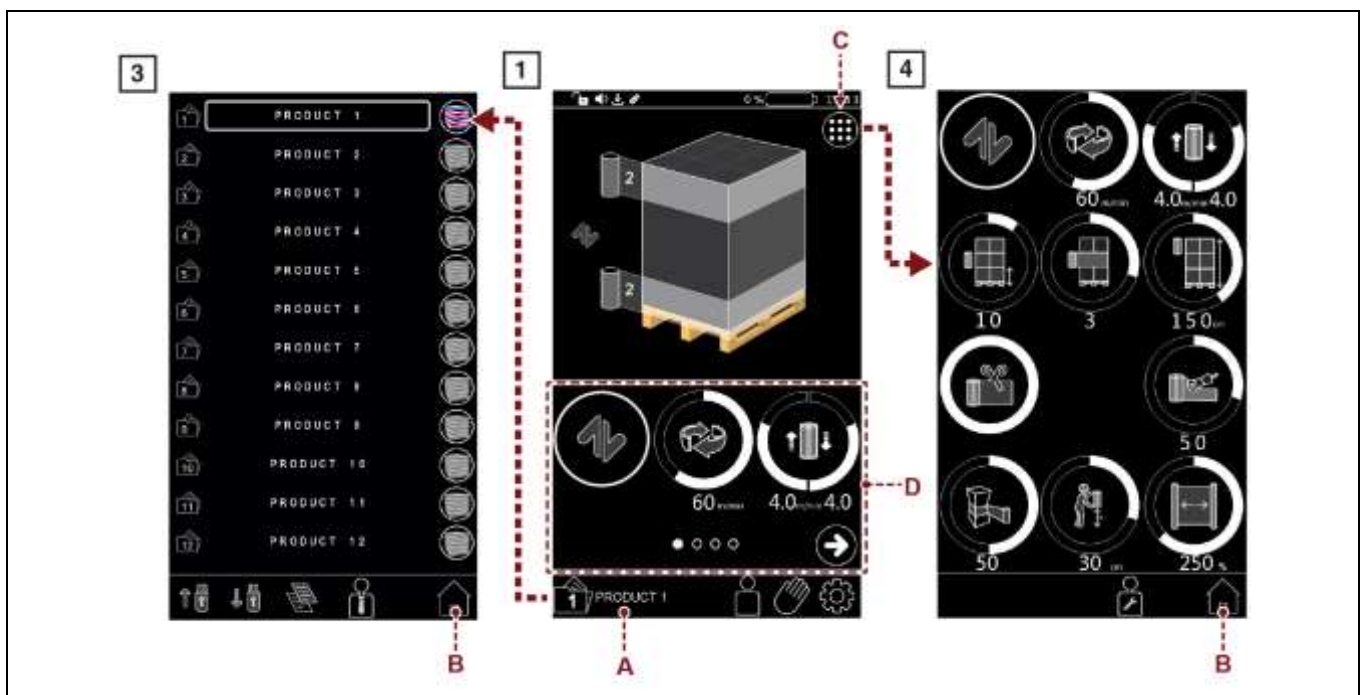

## 6.15. WRAPPING START AND STOP

Proceed as follows.

1. Press the button (A) to enable the power supply of controls.  
The digital display (B) turns on.
2. Press the button (C) to reset the machine.
3. Use the buttons (D) to move the machine closer to the pallet, until the feeler wheel (E) leans against the pallet.
4. Check that the feeler wheel (E) is aligned with the pallet and not with the product.  
Adjust the height of the feeler wheel.  
(See "Adjusting the height of the feeler wheel").
5. Let the film adhere to the pallet.
6. Set the wrapping mode.  
For further details, see paragraph "Programming a new recipe".
7. Check that the parameters on the "Home" page are correct.



### Caution - warning

Do not stretch or pre-stretch the film excessively and do not wrap the product with too many wrappings in order to prevent damaging the packages and the products contained in them.

8. Press the "Cycle Start" button (F).  
The machine performs the wrapping and, at the end of the set cycle, it stops automatically.
9. Cut the film (manual or automatic cutting).

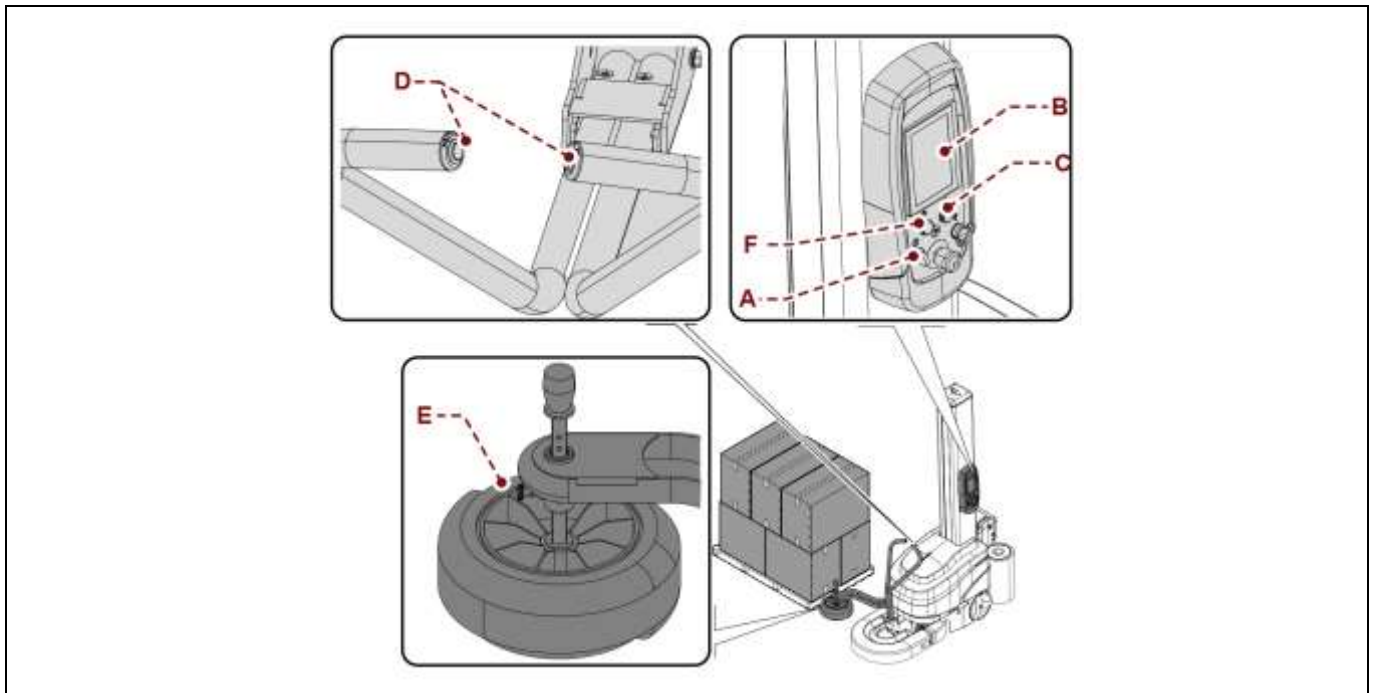

### Important

The machine can autonomously restart the wrapping cycle if it is interrupted by the detection of an obstacle in the safety area. If the safety area is cleared within 15 seconds, an acoustic signal is emitted to indicate that the work cycle has been resumed. If the area remains occupied for a longer time, manual resetting by the operator is required.



### Important

If there is the optional automatic cutting unit, this phase will be automatically performed.  
Information valid only for "feeder cycle" wrapping mode.

- When the machine stops in the pallet upper section, position the TOP sheet (do not cut the film).
- Press the "Cycle Start" button (**C**).  
The machine performs the wrapping and, at the end of the set cycle, it stops at the pallet base.  
At the end of the wrapping phase, the machine can be stopped in "stand-by" mode or switched off.
- When the machine is in "stand-by" mode and it is not used for more than 15 minutes, the "energy saving" operating status is automatically activated.  
To restore the machine operation touch the display.  
If the "Energy saving" function stays on for more than 60 minutes, the machine automatically turns off.
- Press the button (**A**) to switch off the machine voluntarily.

## 6.16.FILM SPOOL FEEDING



### Danger - warning

The operation must be performed by one operator only.



The operation must not be performed by more than one operator.  
Operating modes different from described ones.

Proceed as indicated.

1. Stop the machine (see paragraph "Machine safe stop").
2. The operator must insert the film inside the rollers by hand, making it pass through the roller cone area (A), following the path engraved on the carriage (B).

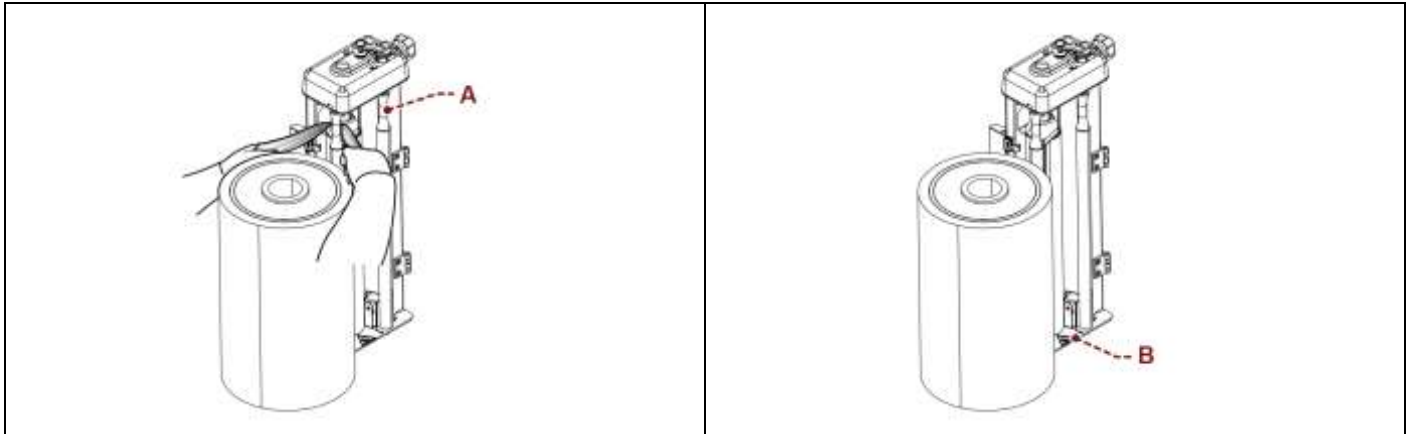

### Important

Unwind the film following the path engraved on the film carriage plate.  
"FRD for mesh" film carriage.

Unwind the film as shown in the relevant plate.

3. Pull the cord outwards.
  - The film automatically moves down to the roller and covers it over its entire length.  
To allow film or mesh routing between rollers and unwinding on carriages of "FRD" type, it is necessary to unlock the brake by turning the handwheel (C) to pos. "0".

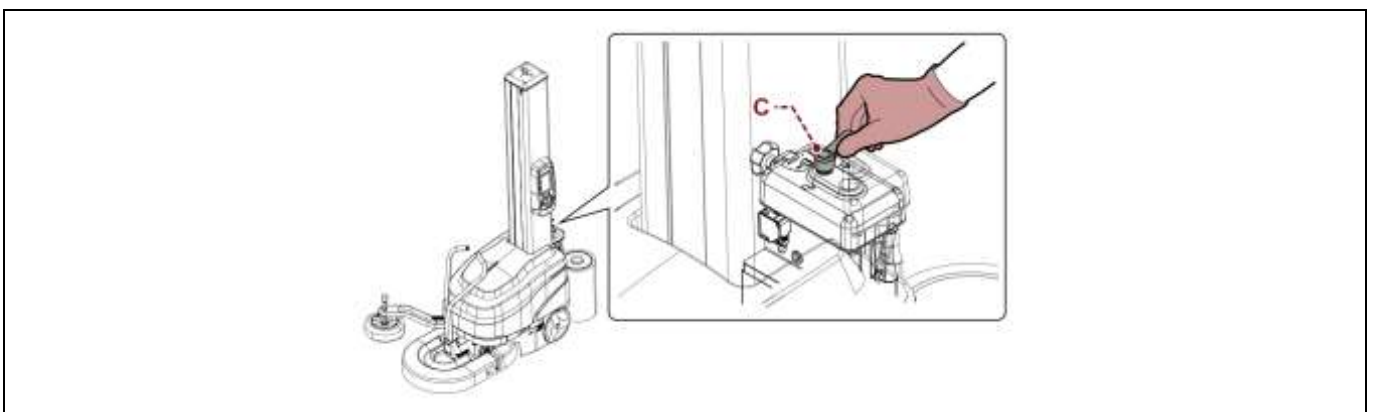

### 6.17. FILM REEL FEEDING (APPLICABLE TO "P3GS" AND "PVS" CARRIAGES ONLY)

1. In "MANUAL HANDLING" mode bring the carriage all down.
2. Extract the terminated film reel, insert the new film reel (A) in the relevant seat on the film carriage.
3. In "MANUAL HANDLING" mode bring the carriage to a suitable height to insert the film. The base of the carriage should approximately be at a height between 850 and 1100 mm from the ground, according to the operator's height.
4. Open the door (B) using the lever (C).
5. Collect the film until a thin cord is obtained and route it in the opening (D) as indicated.

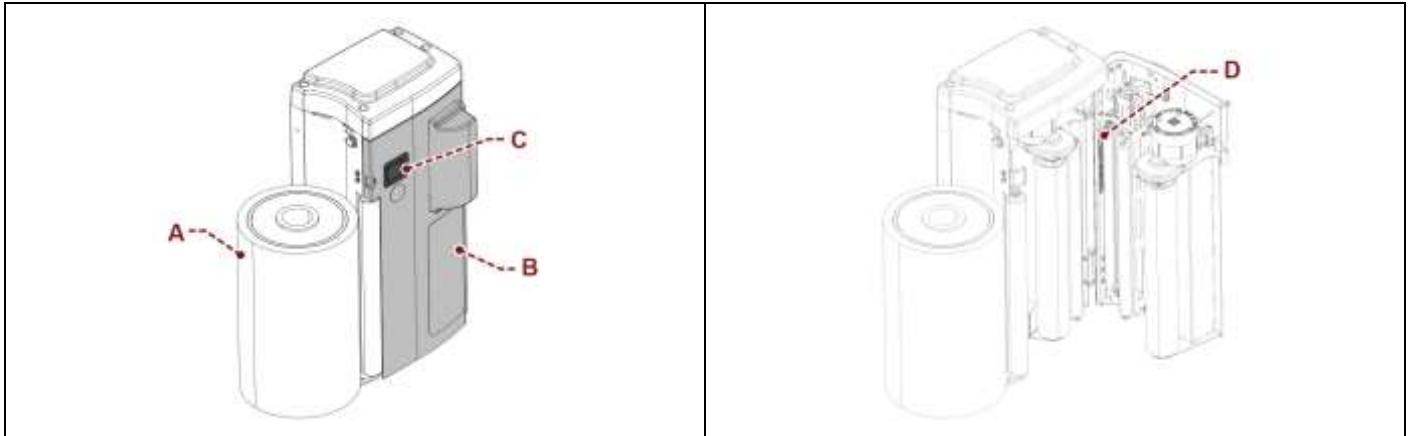

6. Pull the film outwards.
7. Close the door (B).



**Danger - warning**

The operation must be performed by one operator only.



The operation must not be performed by more than one operator.

Operating modes other than the ones described can be harmful to the operator, and film insertion may prove more difficult.

## 6.18. BATTERY CHARGER MODE

When the minimum charging threshold is reached, the machine automatically stops to preserve the battery service life. The minimum charge threshold is indicated in multiple places:

- On the battery display, with the red flashing bar which is still in the reference icon
- On the LED indicator placed on the machine casing.

The wrapping cycle in progress is completed and then the display shows the alarm "E9001" (low battery). When this alarm is displayed, you can only move the machine to the charging area.



### Important

The battery must be charged in rooms protected against atmospheric agents, well vented and outside of the work environment.



Follow the instructions carefully.



Use goggles



Smoking is forbidden



Electrolyte is highly corrosive.

In case of contact with electrolyte, wash with plenty of running water and contact the first aid station or seek medical advice - Refer to the battery specific instructions.

Proceed as follows.

1. Switch the machine off.
2. Lift the battery casing (A).  
With the additional battery kit, just replace the tray containing the low batteries (see "Battery replacement") with the one containing already charged batteries.
3. Insert the power plug into a power outlet.

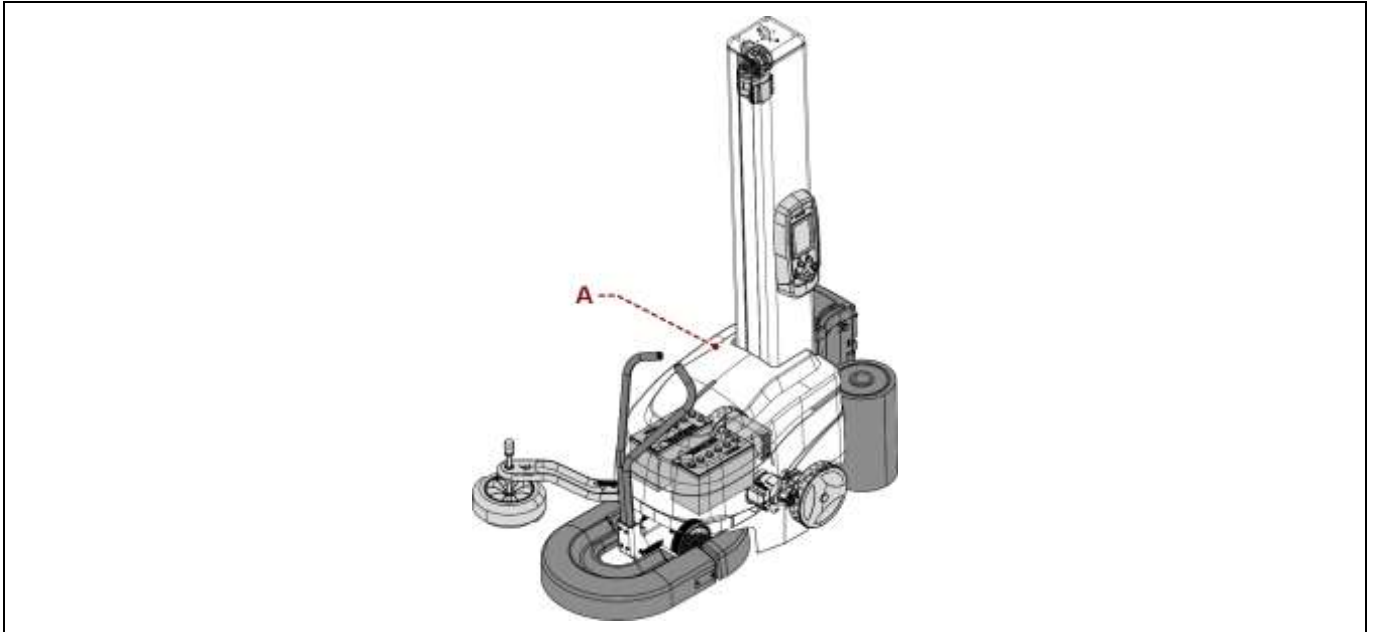

**Important**

If this operation is performed with the machine on, it will automatically switch off during the final charging phase.

It is recommended to perform the operations with the machine off (central button indicator light off).

4. Perform and monitor the charging cycle according to the procedure described in the electronic battery charger operation manual.  
For further details see the relevant manual.  
Once the charging is complete, disconnect the power plug and close the casing.
5. Restart the machine after having made sure that the battery charging is complete (battery charger green LED steadily on).

## LITHIUM-ION BATTERY RECHARGE

Lithium-ion batteries do not require the casing to be lifted.

Proceed as follows.

1. With the machine on, connect the supplied power cord to the IEC socket on the side of the machine.
2. Connect the other end of the cord to the power supply plug.

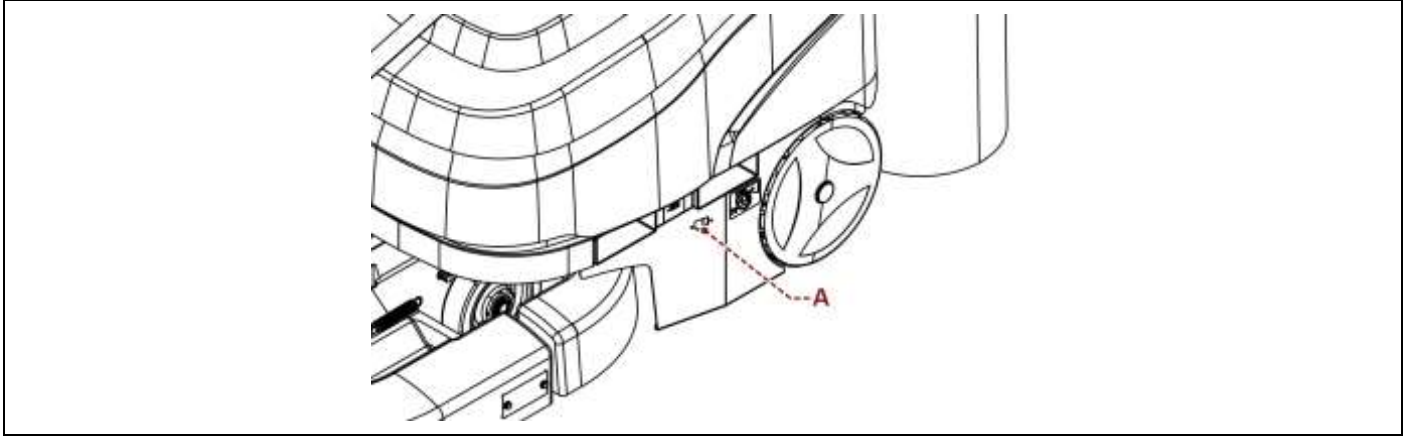

## 7. MAINTENANCE INFORMATION

### 7.1. RECOMMENDATIONS FOR MAINTENANCE

- Stop the machine (as indicated in paragraph “machine safe stop”).
- Proper maintenance will allow a longer life span and constant compliance with safety requirements.
- Before performing any operation, the authorised operator must make sure to have understood the “Instructions for use”.
- Pay attention to the safety warnings, do not misuse the machine and assess the possible residual risks.
- Carry out the interventions with all the safety devices enabled and wear the required PPE.
- Indicate the intervention areas and prevent access to the devices that, if activated, could cause unexpected hazards and compromise safety.
- Do not carry out interventions that are not described in the manual but contact an service centre authorised by the Manufacturer.
- Do not dispose of materials, polluting liquids and the waste generated during the interventions into the environment but dispose of them according to the standards in force.

### 7.2. PERIODICAL MAINTENANCE INTERVALS

The table indicates the scheduled maintenance intervals which allow to obtain best performance, long operating life and a constant level of safety.

Maintenance interval table

Frequency	Component	Type of intervention	Intervention mode	Reference
Every 40 hours or 1000 cycles (*)	Machine working areas	Clean	Use a cloth or air jet	-
Every 200 hours or 5000 cycles (*)	Rubber rollers	Clean	Use a cloth soaked in alcohol	-
Every 200 hours or 5000 cycles (*)	Film carriage	Lubricate	-	See “Lubrication point diagram”
		Check the chain tensioning	-	See “Film carriage lifting chain adjustment”
Every 5000 hours or 50000 cycles (*)	Reduction units and gearmotors	Change the lubricant <sup>1</sup>	-	See “Lubrication point diagram”
Every 10000 hours or 100000 cycles (*)	Steering return spring	Replace		

<sup>1</sup> Do not top up and/or change in life-lubed reduction units and gearmotors.

\* Cycle timings have been defined on the basis of the standard cycle.

The standard cycle is the following: **500 mm** high film reel, **1500 mm** high pallet, pallet weight equal to **1500 kg**, total wrapping cycle consisting of two turns at the base, two turns at the top with rotation speed of **12 r.p.m.** or **80 m/1'** and carriage upstroke and downstroke speed equal to **4 m/1'**.

### 7.3. LUBRICATION POINT DIAGRAM

The diagram shows the main parts concerned by the lubrication interventions and their intervals.

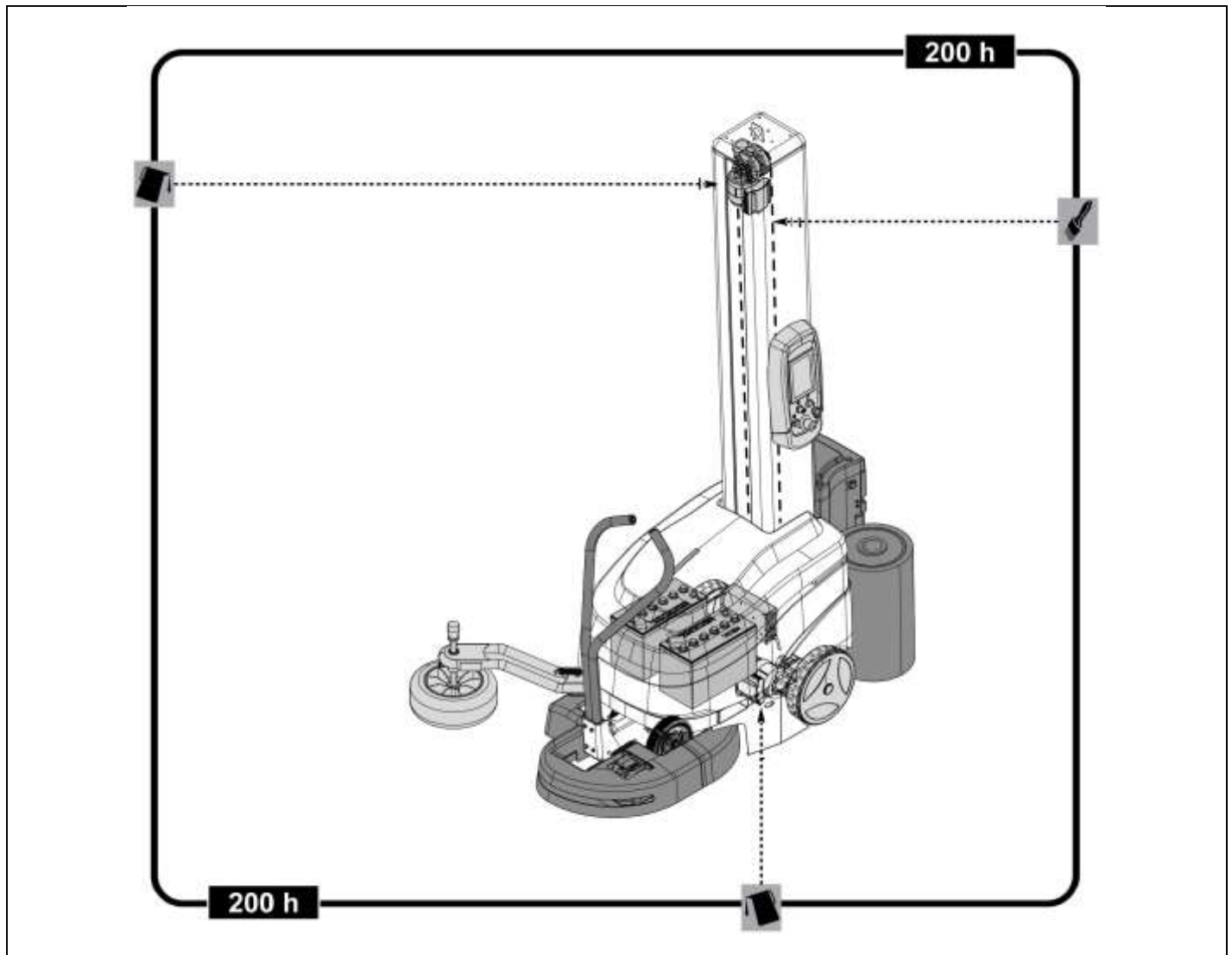

	Spread grease over it.
	Check the lubricant level. Do not top up and/or change in life-lubed reduction units and gearmotors.



**Important**

Observe the lubrication frequency to obtain the best performance and a longer machine's operating life. Use lubricants (oils and greases) recommended by the Manufacturer or with similar chemical-physical features.

## 7.4. LUBRICANT TABLE

The table below lists the specifications of the lubricants recommended by the Manufacturer for each component and/or areas of reference.

**Use lubricants (oils and greases) recommended by the Manufacturer or with similar chemical-physical features.**

### Lubricant characteristics

Lubricant type	Code	Parts to be lubricated
Mineral oil	23°C / 50°C - 320 CST 40°C MELLANA OIL 320 IP SPARTAN EP 320 ESSO BLASIA 320 AGIP MOBILGEAR 632 MOBIL OMALA EP 320 SHELL ENERGOL GR-XP 320 BP	Gear reduction unit
Mineral oil	32°C / 50°C - 460 CST 40°C MELLANA OIL 460 IP SPARTAN EP 460 ESSO BLASIA 460 AGIP MOBILGEAR 634 MOBIL OMALA EP 460 SHELL ENERGOL GR-XP 460 BP	Worm screw reduction unit
Grease	TELESIA COMPOUND B IP STRUCTOVIS P LIQUID KLUBER TOTALCARTER SYOO TOTAL	Gear reduction unit and worm screw reduction unit
Synthetic oil	TELESIA OIL IP SYNTHESO D 220 EP KLUBER BLASIA S 220 AGIP	Gear reduction unit and worm screw reduction unit
Lithium grease	ALVANIA R2 SHELL HL 2 ARAL ENERGREASE LS2 BP BEACON 2 ESSO MOBILIX MOBIL	Bearings with support
Synthetic oil	+5°C / +5°C VG 68 (SAE 20) +5°C / +25°C VG 100 (SAE 30)	Spool carriage chain



### Important

Do not mix together oils of different brands or having different characteristics.

## 8. FAULT INFORMATION

### 8.1. ALARM MESSAGES

In the event of a breakdown during operation the machine stops automatically and alarm messages appear on the display.

The table lists the displayed messages, the type of problem, the causes and possible solutions.



#### Important

For these operations a precise technical expertise or ability is required; therefore, these operations must be exclusively performed by qualified personnel with certified experience acquired in the specific field of intervention.

#### List of alarms

Code	Problem	Cause	Solution
E1001	Emergency stop alarm	Emergency stop button is blocked	Reset the button and press the "Reset" button.
E1003	Emergency laser scanner	The bumper has hit an obstacle in the working area	Remove the obstacle and press the "Reset" button.
E1010	Carriage door open	The carriage door has been opened	Close the door
E1050	Rudder alarm	The cycle start button is pressed when the rudder is in the low position. The rudder is lowered during the automatic wrapping cycle.	Reset the rudder to the top position and press the "Reset" button
E1055	Speed alarm	A movement of the motorised wheel is detected without any manual control or wrapping cycle in progress. A speed higher than the threshold for operation is detected.	Check the wiring of the automatic machine signal from the automation PLC to the safety PLC by consulting the wiring diagram. Check the operation of the drive motor Press the "Reset" button.
E1060	Laser scanner error	Laser scanner malfunction.	Check the message on the laser scanner display and refer to the manufacturer's operating manual. To reset this alarm it may be necessary to switch the robot off and on again.
E1061	Speed sensors error	Speed detection system malfunction.	Check the condition of the phonic wheel and its sensors and check the wiring by consulting the wiring diagram. To reset the alarm, the robot must be switched off and on again.
E1062	PLC signal error	The automatic machine signal from the automation PLC to the safety PLC is shorted to +24V.	Check the wiring of the automatic machine signal from the automation PLC to the safety PLC by consulting the wiring diagram. Press the "Reset" button to clear the alarm.
E1063	Power contactor feedback error	The display does not exit the reset page.	Check the status of the reset button and contactors and check their wiring by referring to the wiring diagram.

E1090	Battery charging / charging completed	Charge in progress	Wait for the end of the charge
E3110	Drive motor alarm	Drive motor failure.	Check motor operation and refer to alarm indication on the left, refer to drive manufacturer's documentation.
E3210	Lifting motor alarm	Lifting motor failure.	
E3310	Film unwinding motor alarm	Film unwinding motor failure.	
E3410	Film pre-stretch motor alarm	Film pre-stretch motor failure.	
E3510	Roping device motor alarm	Roping device motor failure.	
E6101	Inner wheel is not moving forward	Raised wheel or encoder problem	Release the release lever and/or check sensor and related wiring
E6102	Outer wheel locked	Motor and/or encoder fault	Check the operation of the motor board and see the wiring diagram
E6103	Non-conforming movement	Steering arm not in correct position or wheel encoder malfunction	Check steering arm spring and check wheel encoders, refer to wiring diagram
E6201	Lifting motor is not moving	Check the operation of the board and see the wiring diagram.	Check the operation of the motor, make sure that the lifting device is free to move and consult the wiring diagram
E6202	Error on top and bottom limit stop sensors of the lifting device	Both sensors are active at the same time	Check the sensors and the relevant wiring, refer to the wiring diagram
E6301	Film breakage detected by load cell sensor	The film has broken or the reel is finished	Insert the film or replace the reel
E6302	Film breakage detected by film unwinding sensor		
E6303	Load cell sensor failure, value too low	Load cell sensor malfunction	Check for mechanical obstructions, check wiring, refer to wiring diagram
E6304	Load cell sensor failure, value too high		
E6305	Load cell sensor failure, no-load value not compliant		
E6306	Load cell setting fault		
E6401	Roping device motor alarm	Roping motor malfunction	Check motor operation and refer to alarm indication on the left, refer to drive manufacturer's documentation
E6402	Error on top and bottom limit stop sensors of the roping device	Both sensors are active at the same time	Check the sensors and the relevant wiring, refer to the wiring diagram
E6403	Roping motor is not moving	Motor/encoder malfunction	Check the operation of the motor, make sure that the roping system is free to move and refer to the wiring diagram
E6801	Carriage electric control board open	The door of the carriage has been left open and the carriage has performed a downstroke movement, possible impact with the mechanic components of the machine	Close the door

E6802	Only manual operations are possible	Rudder in low position	Raise the rudder. Check the sensor operation and consult the wiring diagram
E8001	Communication error with main board	Disconnected cable or board malfunction.	Check the operation of the board and see the wiring diagram.
E8002	Communication error with carriage board		
E8011	Communication error with HMI board		
E8012	Communication error with carriage board		
E8031	Communication error with traction motor board		
E8032	Communication error with lifting motor board		
E8033	Communication error with film unwinding motor board		
E8034	Communication error with film pre-stretch motor board		
E8035	Communication error with roping device motor board		
E9001	Low battery alarm		
E9010	Incorrectly positioned roping device spool	The started wrapping program foresees a different position of the roping device (high / low)	Follow the instructions in the pictures: open the door, insert the film as instructed and close the door again.
E9030	Improper battery use and charging	The battery is not sufficiently discharged before a charge or the charge is not completed correctly	Use the battery properly

## 9. REPLACEMENT INFORMATION

### 9.1. RECOMMENDATIONS FOR REPLACING MACHINE PARTS

- Before performing any operation, the authorised operator must make sure to have understood the "Instructions for use".
- Carry out the interventions with all the safety devices enabled and wear the required PPE.
- Demarcate the surrounding areas and put in place adequate safety measures, as provided for by the standards on workplace safety, in order to prevent and minimise the risks.
- Do not carry out interventions that are not described in the manual but contact an service centre authorised by the Manufacturer.
- Do not dispose of materials, polluting liquids and the waste generated during the interventions into the environment but dispose of them according to the standards in force.
- Replace the components only with original spare parts or parts with similar design and construction features. The use of similar but non-original spare parts may result in improper repairs, altered performance and economic damage.
- Safety components and/or devices must be replaced only with original spare parts to preserve the safety level required.



#### **Important**

Before performing any maintenance operation, activate all safety devices provided and evaluate whether it is necessary to inform the personnel operating on the machine and the personnel nearby.

In particular, demarcate the neighbouring areas to prevent access to the devices that could, if activated, cause unexpected hazardous conditions posing a risk for people's safety and health.

When replacing worn parts, use only original spare parts.

The Manufacturer is not responsible for any damage to property or injuries to people caused by the use of non-genuine spare parts or which may result from repairs not authorised by the Manufacturer.

When ordering new spare parts, follow the instructions given in the spare parts catalogue.

## 9.2. BATTERY REPLACEMENT

Proceed as indicated.



### Caution - warning

The main fuse of the machine is built into the battery cables, use only original cables.

1. Lift the battery casing (A).
2. Remove the connector (B) from the plug.
3. Disconnect the terminals (C-D-E-F).



### Caution - warning

First disconnect the negative terminal (-).

4. Extract the batteries (G) and replace them.
5. Reconnect the terminals (C-D-E-F).



### Caution - warning

Respect the polarities when connecting the terminals.  
Grease the positive terminal (+) and connect it first.

6. Engage the connector (B) to the plug.
7. Lower the casing (A).



### Important

Do not dispose of used batteries into the environment.  
Dispose of them in compliance with current regulations (See attached documentation).



### Danger - warning

Warning: heavy batteries.  
Their removal requires two operators or a suitable lifting means.



### Danger - warning

Warning: risk of crashing hands during the removal or feet in case of fall to the ground.  
Wear appropriate PPE (protective gloves and shoes).

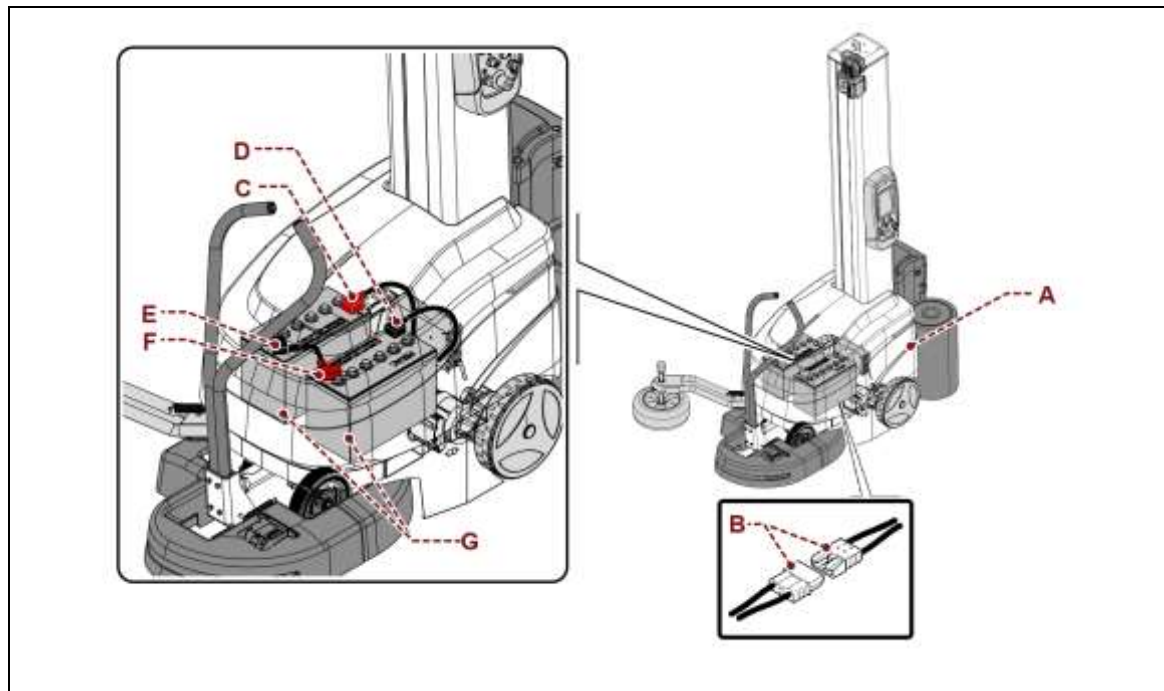

### 9.3. RECOMMENDED SPARE PARTS LIST

List of the spare parts that wear easily and that should be always available to avoid long machine downtimes:

- Braked roller pad (Only for film carriages of "FRD" type).
- Batteries.
- Front wheels.
- Rear wheels

To order them, contact your local dealer and refer to the spare parts catalogue.

### 9.4. MACHINE DECOMMISSIONING AND SCRAPPING

#### 9.4.1. MACHINE DECOMMISSIONING

- Cut off any supply to the machine (power, pneumatic, etc.) so that it cannot be restarted and position it in a place that cannot be easily accessed.
- Empty the systems, which contain hazardous substances, in a proper manner and in compliance with the laws in force at workplaces and with those on environmental protection.

#### 9.4.2. MACHINE SCRAPPING

- Scrapping must be performed by authorised centres with experienced personnel and by using the appropriate equipment for safe operating conditions.
- The person who performs the scrapping must identify any possible residual energies and implement a "safety plan" to eliminate unexpected risks.
- The components must be selected according to the chemical and physical features of the material and disposed of separately, in accordance with the applicable laws.
- Empty the systems, which contain hazardous substances, in a proper manner and in compliance with the laws in force at workplaces and with those on environmental protection.

## 10. ANNEXES

### 10.1. WARRANTY CONDITIONS

**Robopac S.p.A.** commits, within the limits described herein, to replace or repair, free of charge, the parts that are defective during the 12 (twelve) months following the date indicated on the company's shipping documents.

To utilise the warranty, the user must immediately notify the company of the detected fault, always referring to the machine serial number.

**Robopac S.p.A.**, in its final judgement, will decide whether to replace the defective part or request it to be shipped for tests and/or repair.

By replacing or repairing the defective part, **Robopac S.p.A.** fully complies with its warranty obligations and will be released from all liabilities and obligations relative to transport, travel and lodge expenses for technicians and installers.

**Robopac S.p.A.** will in no case be held responsible for any losses due to lack of production or injuries to persons or damage to things caused by malfunctions or forced downtime of the machine covered by the warranty.

#### THE WARRANTY DOES NOT COVER:

- Transport failures.
- Damage due to incorrect installation.
- Improper use of the machine or negligence.
- Tampering with or repairs by unauthorised personnel.
- Lack of maintenance.
- Parts subject to normal wear and tear.

For purchased components and parts, **Robopac S.p.A.** offers the user the same warranty conditions that the company obtains from the suppliers of the aforementioned components and/or parts.

**Robopac S.p.A.** does not guarantee the conformity of machines to current standards in countries that are not part of the European Union.

Any adjustment to the regulations in force in the Country in which the machine is installed, will fall under the full responsibility of the user, who will be responsible also for the changes made, releasing **Robopac S.p.A.** from any obligation and/or liability relative to any claim that may be submitted by third parties due to non-compliance with the referenced standards.

# DECLARATION OF CONFORMITY

(Annex II 1.A of Directive 2006/42/EC)

**The manufacturer:**

**Robopac S.p.A.**  
**Via Fabrizio da Montebello, 81**  
 47892 - Gualdicciolo  
 Republic of San Marino

of the machine identified as follows:

DENOMINAZIONE DENOMINATION	
MODELLO MODEL	
MATRICOLA SERIAL NUMBER	

## DECLARES

under its own responsibility that this machine is compliant with the following European directives:

DIRECTIVE 2006/42/EC OF THE EUROPEAN PARLIAMENT AND OF THE COUNCIL of 17 May 2006 on machinery, and amending Directive 95/16/EC;

DIRECTIVE 2014/30/EU OF THE EUROPEAN PARLIAMENT AND OF THE COUNCIL of 26 February 2014 on the harmonisation of the laws of the Member States relating to electromagnetic compatibility;

and with the following harmonised standards at the applicable points:

EN ISO 12100:2010, EN 60204-1:2018, EN 415-10:2014.

**THE PERSON AUTHORISED BY THE MANUFACTURER TO PREPARE THE TECHNICAL REPORT AND DRAW UP THE DECLARATION OF CONFORMITY IS:**

**Engineer Cristiano Casale**  
**R&D Manager**

**c/o Aetna Group S.p.A.**

**S. P. Marecchia, 59**

**47826 Villa Verucchio**

**Rimini (Italy)**

**Date and place of signature**

**Robopac S.p.A.**

**San Marino,**

**Engineer Cristiano Casale**  
**R&D Manager**

---

**ROBOPAC SPA**

Via Fabrizio da Montebello, 81 – 47892 Gualdicciolo, Repubblica S. Marino (RSM)  
Phone (+378) 0549 910511 - Fax (+378) 0549 908549 – 905946  
<http://www.robopac.com>