

TECHNICAL DOCUMENTATION

- ROBOT S6 (KINKO)





Norm. Tecn.
60.2.49_14

TECHNICAL DOCUMENTATION
- ROBOT S6 (Touch Screen Kinco Version) -

Date:
October 2021

Rev.16

ENGLISH

Pag. 2 / 113

Date	Revisions	Revisions Reasons	Issue	Cheched by	Approved by
28/03/2012	01	First Issue	<i>Saravelli D.</i>	<i>Saravelli D.</i>	<i>Saravelli D.</i>
16/01/2013	02	Software Revision sw rel.6.0	<i>Saravelli D.</i>	<i>Saravelli D.</i>	<i>Saravelli D.</i>
03/11/2016	03	General review - Kinco	<i>Zavoli S.</i>	<i>Zavoli S.</i>	<i>Zavoli S.</i>
26/04/2017	04	Carriages and Stretch Control	<i>Baldinini F.</i>	<i>Baldinini F.</i>	<i>Baldinini F.</i>
08/05/2017	05	Roping device alarm E67	<i>Baldinini F.</i>	<i>Baldinini F.</i>	<i>Baldinini F.</i>
21/06/2017	06	Roping device calibration	<i>Baldinini F.</i>	<i>Baldinini F.</i>	<i>Baldinini F.</i>
18/09/2017	07	New photocell for black products	<i>Baldinini F.</i>	<i>Baldinini F.</i>	<i>Baldinini F.</i>
01/03/2018	08	R-connect and Roping working values	<i>Baldinini F.</i>	<i>Baldinini F.</i>	<i>Baldinini F.</i>
04/05/2018	09	NORD ELETTRONICA Battray charger status and alarms	<i>Baldinini F.</i>	<i>Baldinini F.</i>	<i>Baldinini F.</i>
12/06/2018	10	Addition E32 alarm (was missing)	<i>Baldinini F.</i>	<i>Baldinini F.</i>	<i>Baldinini F.</i>
09/07/2018	11	Index realization	<i>Baldinini F.</i>	<i>Baldinini F.</i>	<i>Baldinini F.</i>
20/12/2018	12	Change in the Touch Screen update procedure (first insert USB ...)	<i>Baldinini F.</i>	<i>Baldinini F.</i>	<i>Baldinini F.</i>
03/05/2019	13	Parameter P[35] film weight	<i>Baldinini F.</i>	<i>Baldinini F.</i>	<i>Baldinini F.</i>
04/12/2019	14	Addition E68 alarm	<i>Baldinini F.</i>	<i>Baldinini F.</i>	<i>Baldinini F.</i>
22/04/2021	15	New Kinko panel, modification of parameter P3, E60 alarm modification	<i>Baldinini F.</i>	<i>Baldinini F.</i>	<i>Baldinini F.</i>
26/10/2021	16	Addition of the P31 parameter	<i>Baldinini F.</i>	<i>Baldinini F.</i>	<i>Baldinini F.</i>

 Norm. Tecn. 60.2.49_14	TECHNICAL DOCUMENTATION - ROBOT S6 (Touch Screen Kinco Version) -	Date: October 2021	Rev.16
	ENGLISH	Pag. 3 / 113	

Index

MACHINE LAY-OUT.....	7
FILM SPOOL CARRIAGE DETAILED SKETCHES	8
OPERATOR PANEL DESCRITPION	12
BATTERY STATUS INDICATIONS DISPLAY	12

 Norm. Tecn. 60.2.49_14	TECHNICAL DOCUMENTATION - ROBOT S6 (Touch Screen Kinco Version) -	Date: October 2021	Rev.16
	ENGLISH	Pag. 4 / 113	

DESCRIPTION AND MAIN ELECTRICAL PANEL LAYOUT	13
ROPING DEVICE - DESCRIPTION AND LAYOUT	14
ELECTRONIC CARDS DESCRIPTION	15
PLC + INVERTER Card (Main Board) (U1) - – CODE 1430300180	15
Pre-stretch Card 1 Motor (U3) - – CODE 1430300198	19
Pre-stretch Card 2 Motors (U3) - – CODE 1430300181	23
Control Roping Device Card CORD01ROB (U12) - – CODE 1430300246.....	25
Control Roping Device Card DCM01ROB (U12) – CODE 1430300268.....	26
POWER SAVE” FUNCTION (MACHINE STAND-BY)	27
“POWER SAVE” FUNCTION (MACHINE SHUTDOWN).....	27
LIST OF RECIPES DATA	28
GENERAL FUNCTIONS AVAILABLE ON TOUCH-PANEL	32
HOW TO USE THE ACCESS PASSWORD OF THE OPERATOR TOUCH-PANEL	33
MACHINE’S END-USER SECTION	35
MANUAL functions on the Roping with service password	39
PACKING PARAMETER SETTING	40
Packing cycle parameters description	41
BATTERY TEST CONDITION FUNCTION.....	45
MANUAL FORWARD SPEED ADJUSTMENT FUNCTION.....	45
SERVICE SECTION (MACCHINE MAINTENANCE)	46

 Norm. Tecn. 60.2.49_14	TECHNICAL DOCUMENTATION - ROBOT S6 (Touch Screen Kinco Version) -	Date: October 2021	Rev.16
	ENGLISH	Pag. 5 / 113	

PROCEDURE FOR REPLACING, LOADING SOFTWARE AND CALIBRATION OF ELECTRONIC CARDS	47
TOUCH SCREEN PANEL (U2)	47
New installation MT4414TE-RO KINCO --- till January 2021	47
New installation K-GL070E-RO KINCO --- since January 2021	52
Software update	54
MOTHER-BOARD (U1) SOFTWARE DOWNLOAD PROCEDURE	61
AMPLIFIER CARD / PRE-STRETCH MOTOR INVERTER (U3) SOFTWARE DOWNLOAD PROCEDURE	62
MACHINE SETTINGS AND FUNCTIONS	63
BATTERY AND BATTERY CHARGER SETTING (SPE Model)	64
BATTERY AND BATTERY CHARGER SETTING (NORDELETTRONICA Model)	67
TROUBLESHOOTING THROUGH ALARM HISTORY	72
INTERNAL MACHINE'S PARAMETER AND LOAD-CELL (EXTENSIONMETER) SETTING	73
TROUBLESHOOTING THROUGH INPUTS WORKING DISPLAY	77
LAYOUT MOTHER-BOARD AND I/O DESCRIPTION	78
TROUBLE-SHOOTING AND HIDDEN FUNCTIONS	79
DISPLAYING DATA COMMUNICATION MODBUS	80
GRAPHICAL DISPLAY OF STRETCH AND PRE-STRETCH VALUES	81
PROCEDURE FOR DOWNLOADING SOFTWARE FOR UPGRADING OF THE CONTROL PANEL "TOUCH SCREEN.	82
HIDEN FUNCTIONS.	83
BATTERY CHARGER SPECIFICATIONS (S.P.E)	86
BATTERY CHARGER SPECIFICATIONS (NORD ELETTRONICA)	88
TRACTION MOTOR BRAKE SETTING NOTIONS.....	93

 Norm. Tecn. 60.2.49_14	TECHNICAL DOCUMENTATION - ROBOT S6 (Touch Screen Kinco Version) -	Date: October 2021	Rev.16
	ENGLISH	Pag. 6 / 113	

PRODUCT HEIGHT DETECTION PHOTOCELL CALIBRATION.....	94
Standard photocell (for clear products).....	94
Dark product photocell (Datalogic model)	95
Dark product photocell (Sunx model).....	96
Photocell for black products S65	97
POWER VOLTAGE TEST FOR SPOOL CARRIAGE CLUTCH / BRAKE	98
ROPING DEVICE CALIBRATION	98
R-CONNECT DEVICE ACTIVATION.....	99
ALARM LIST AND TROUBLE-SHOOTING	100

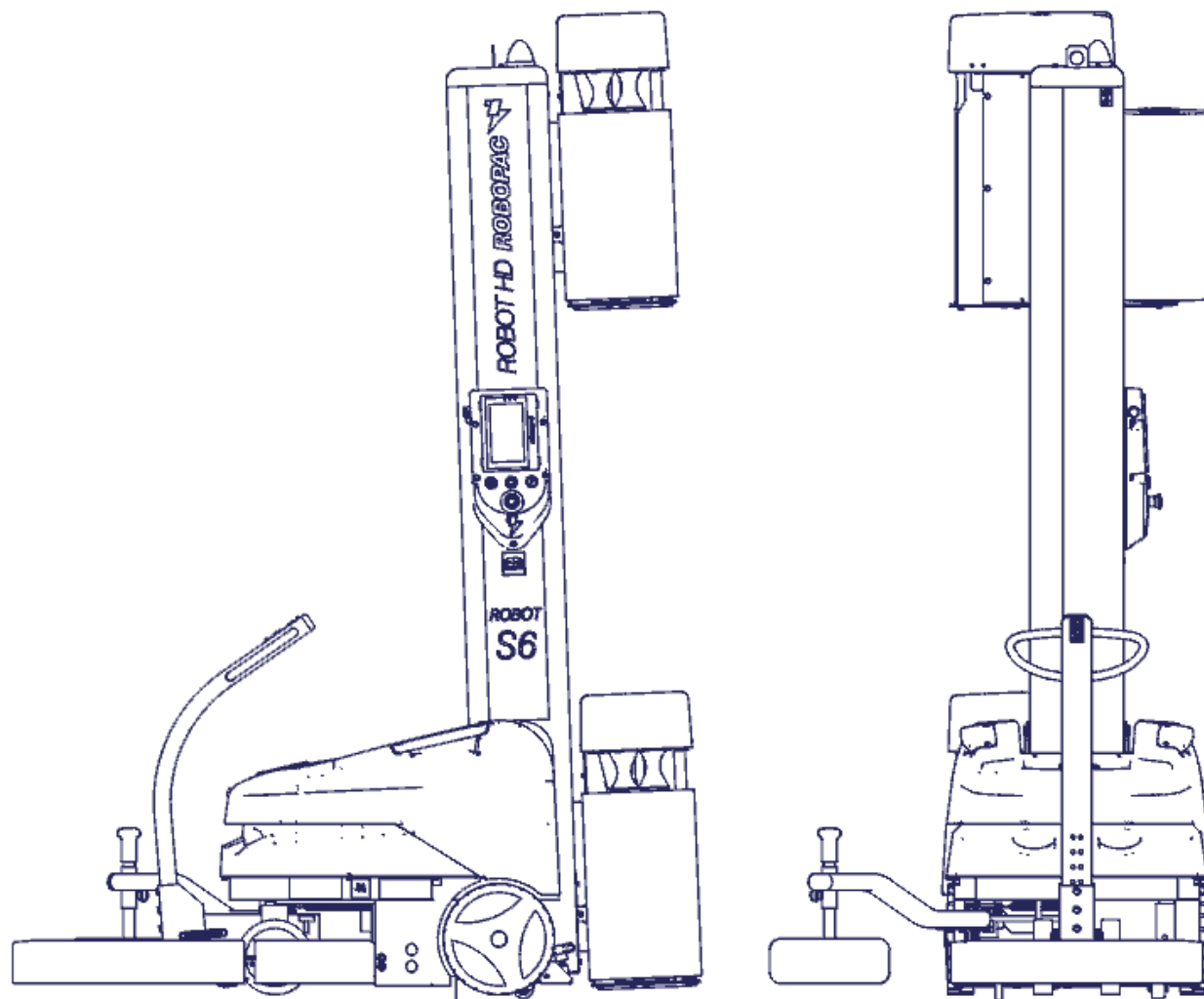
MACHINE LAY-OUT

FILM SPOOL CARRIAGE DETAILED SKETCHES

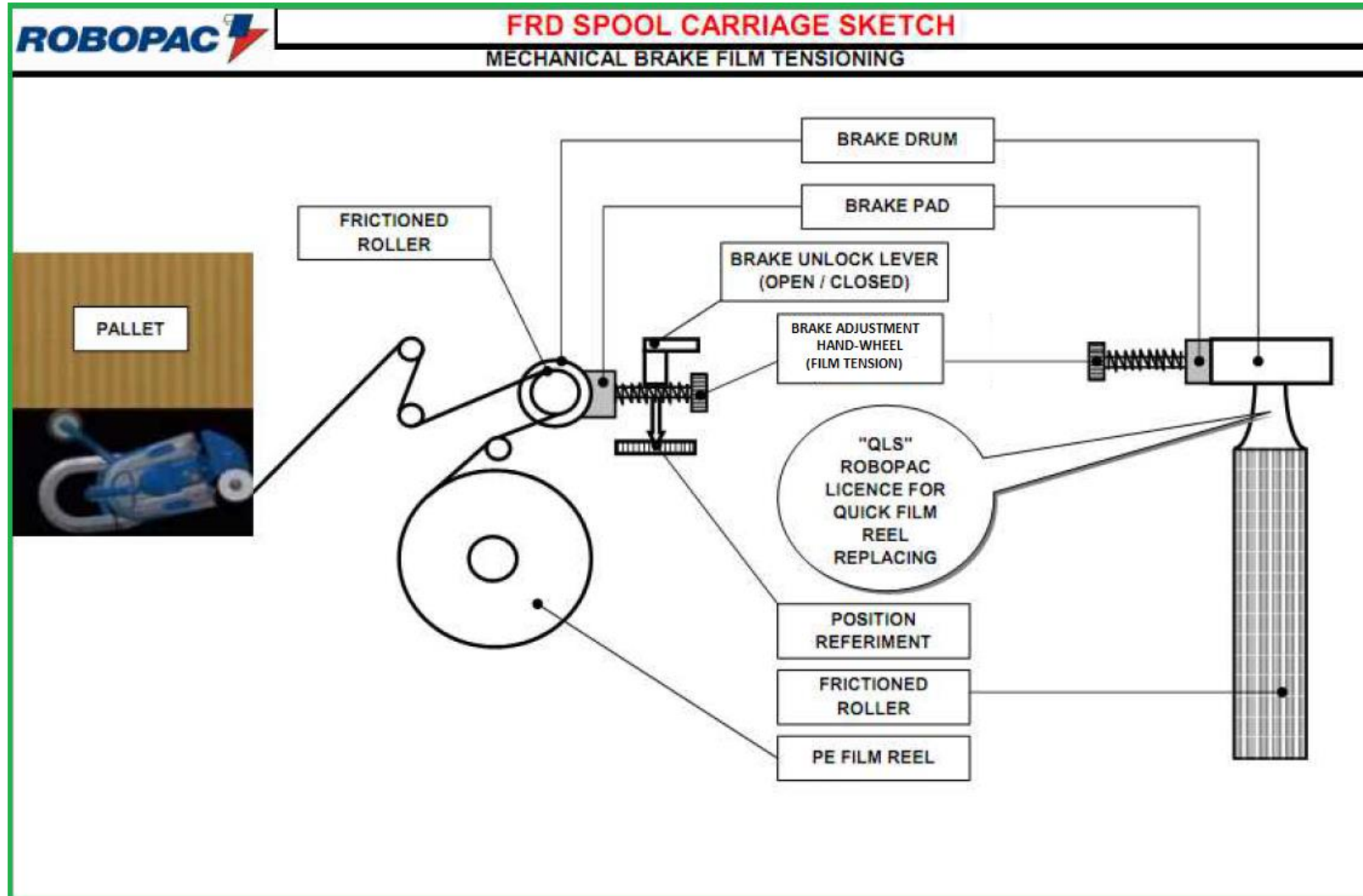

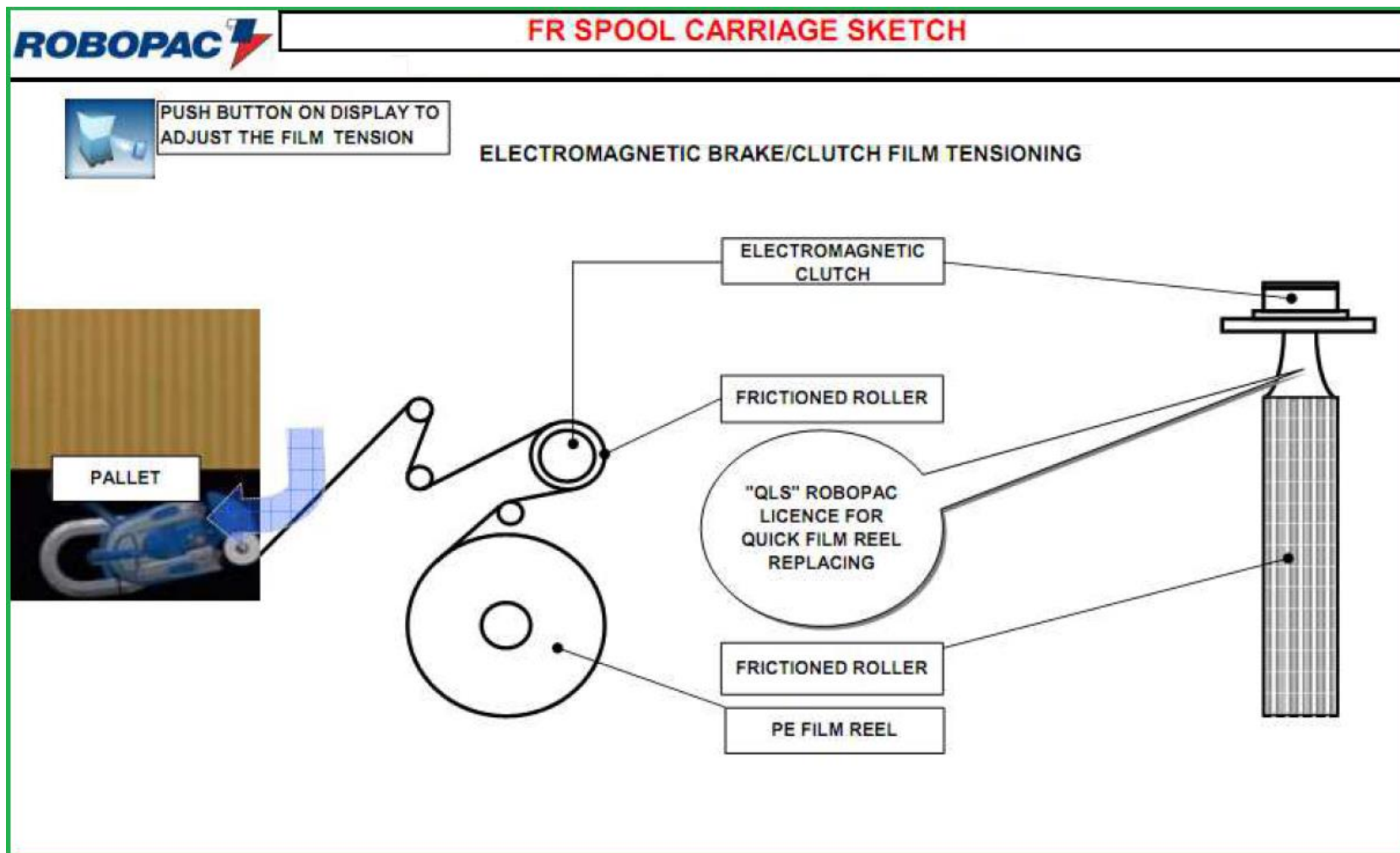

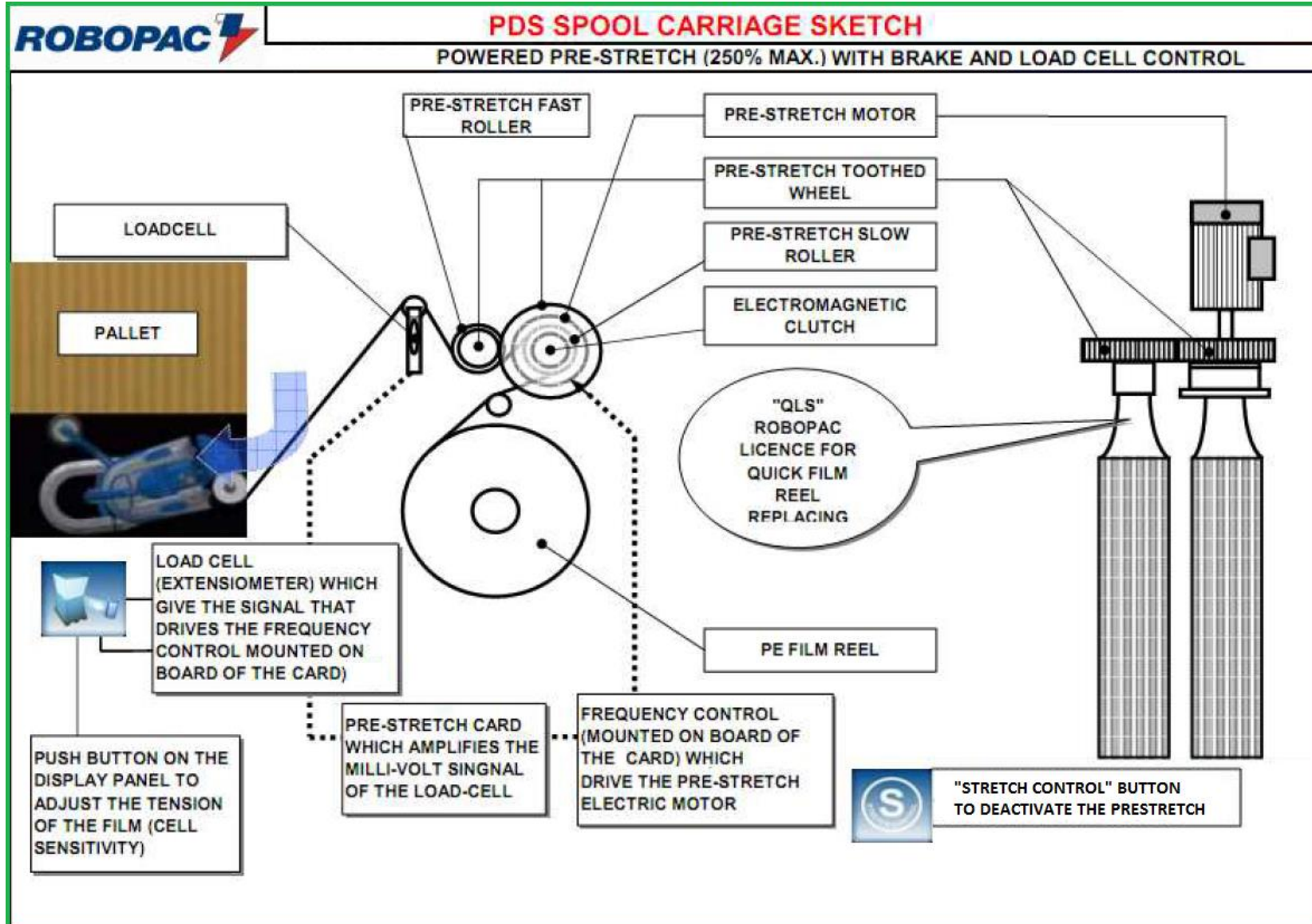

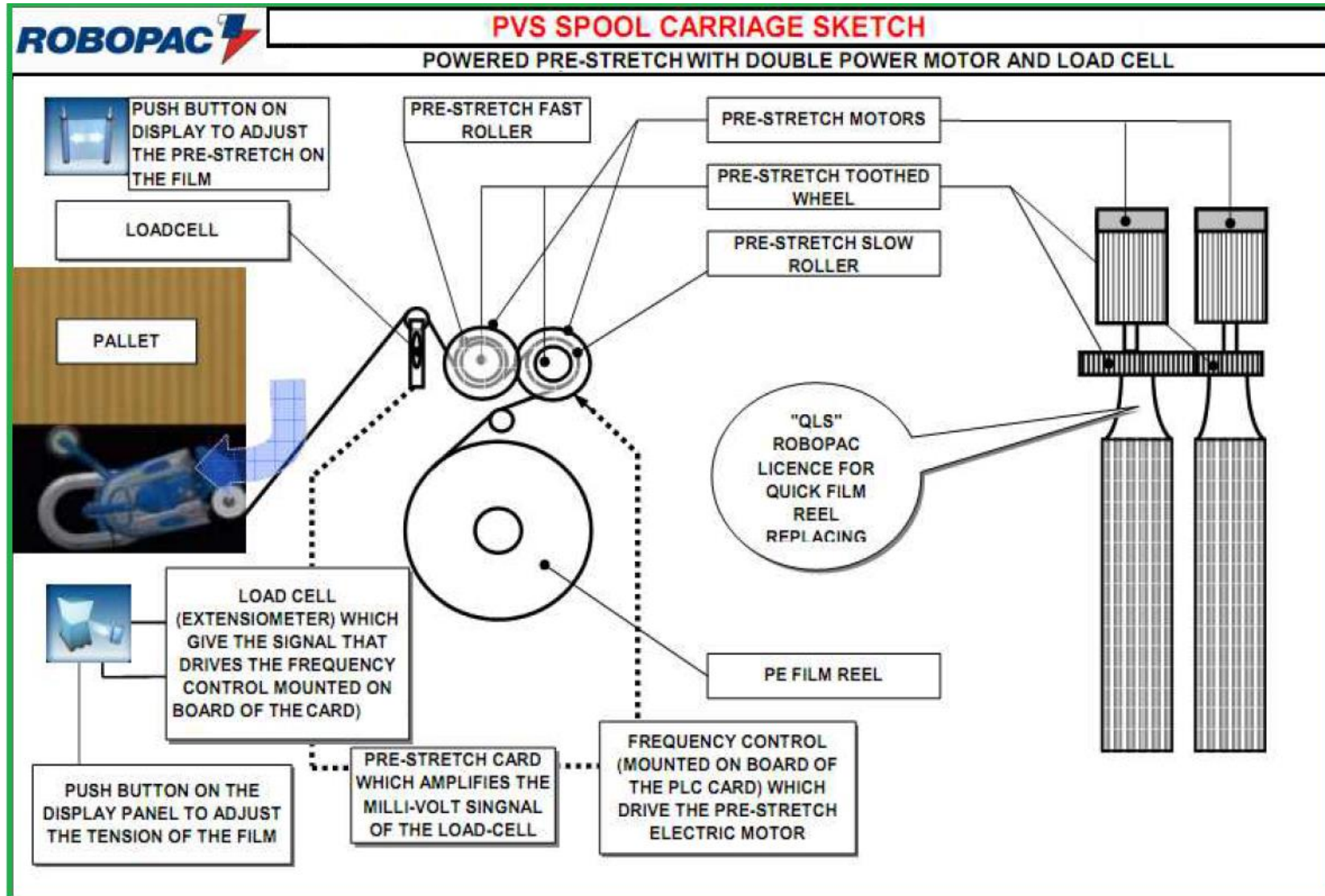

OPERATOR PANEL DESCRIPION



+ iN

BATTERY STATUS INDICATIONS DISPLAY

	Battery under charge
	Battery charge level 10% - E90 alarm
	Battery charge level 30%
	Battery charge level 80%
	Battery charge level 100%

DESCRIPTION AND MAIN ELECTRICAL PANEL LAYOUT

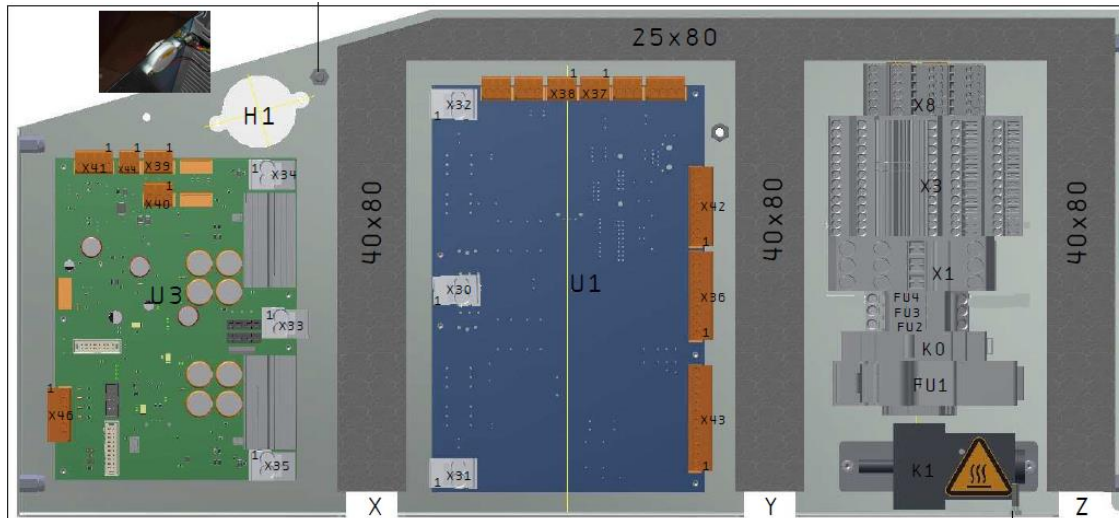

The part numbers are for information only.
Always check and verify the codes on the wiring diagram supplied with the machine.

U1 - ELETTRONICA ROBOT S6 Plc Card
code 1430300180

U3 - PRESTIRO 1M ROBOT S6 Pre-Stretch Inverter Card
code 1430300198

U3 - PRESTIRO 2M ROBOT S6 Pre-Stretch Inverter Card
code 1430300181

FU1 - Power Supply Fuse CILIND. 14X51 GG 50A 500V
code 001304227

FU2 - ChargeBattery Fuse MIN 5X20 RITARD. 4,000 AMP 250VAC
code 001304080

FU3 - Fuse MIN 5X20 RAP 2A 250VAC
code 001304031

FU4 - Fuse MIN 5X20 RITARD. 4,000 AMP 250VAC
code 001304080

K0 -ON/Off Relay RELE' IND. 24,0 VDC 20-22-9-024-00000
code 001304323

K1 -Emergency Contactor CONT.POT. ETL20PA
code 0470300003

ROPING DEVICE - DESCRIPTION AND LAYOUT

The part numbers are for information only.
Always check and verify the codes on the wiring
diagram supplied with the machine.

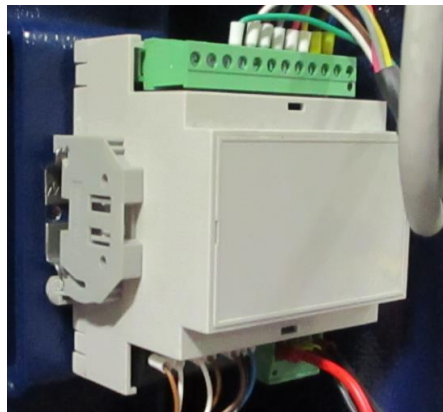

U12 - Roping Control Card DCM01ROB
code 1430300268

ELECTRONIC CARDS DESCRIPTION

PLC + INVERTER Card (Main Board) (U1) -- CODE 1430300180

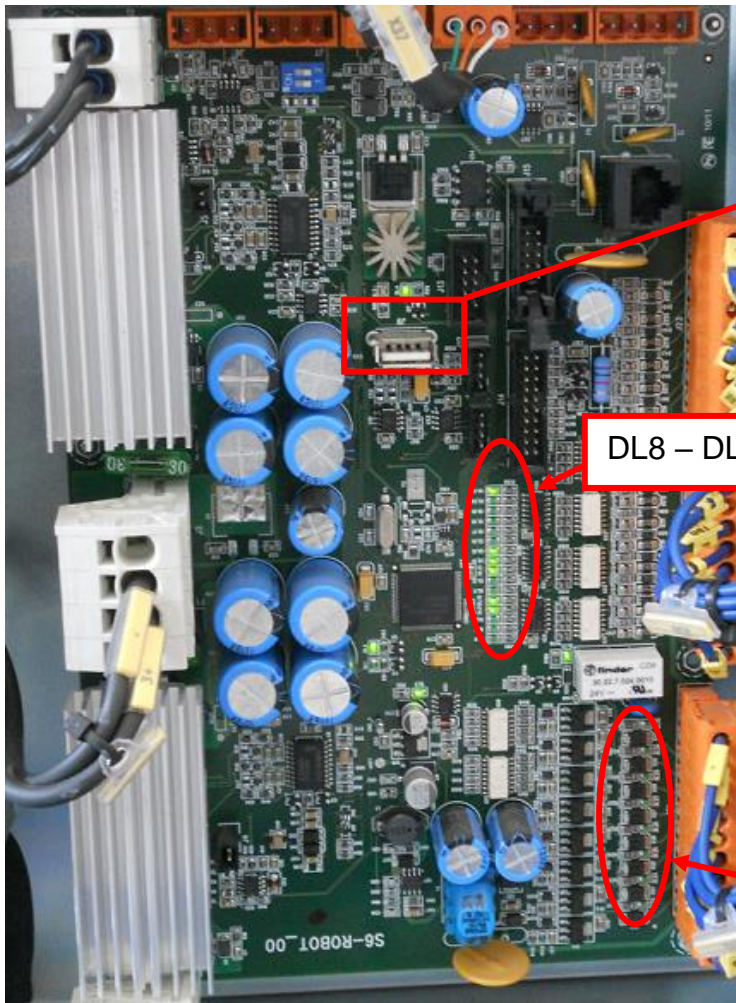

J10 USB port
connection to
download the
software into the
machine's
mother-board

DL8 - DL23

DL25 - DL32

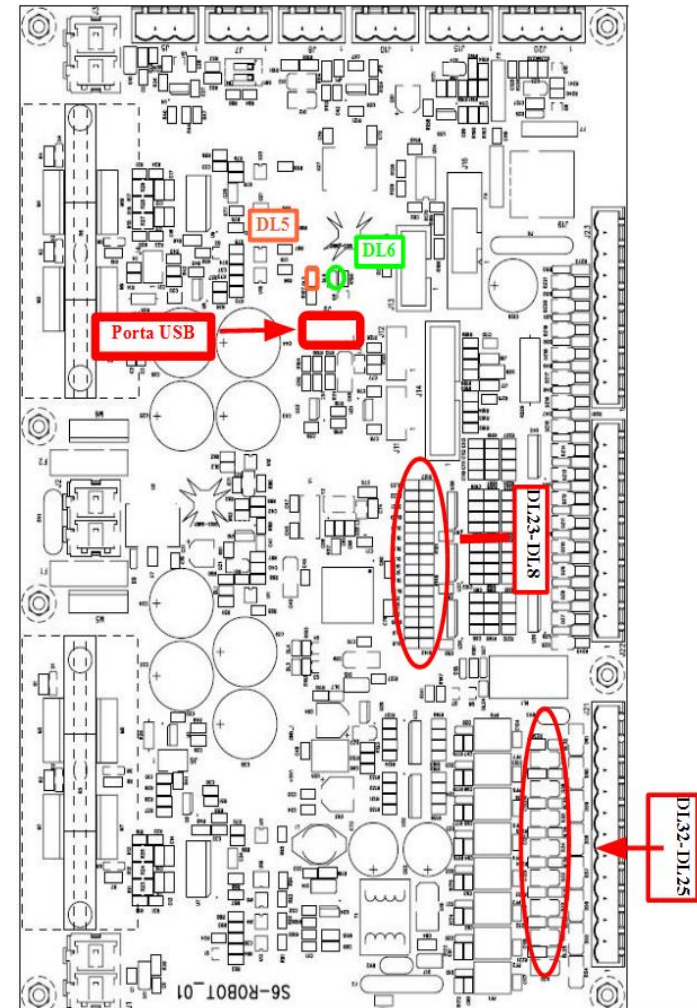

X30/J2 Connector – Pin Table description

Pin Number	Signal Description
1	Inverter Supply(+)
2	Inverter Supply(-)

X31/J1 Connector – Pin Table description

Pin Number	Signal Description
1	M1 Command Rotation Motor
2	M1 Command Rotation Motor

X32/J3 Connector – Pin Table description

Pin Number	Signal Description
1	M2 Command Carriage Motor
2	M2 Command Carriage Motor

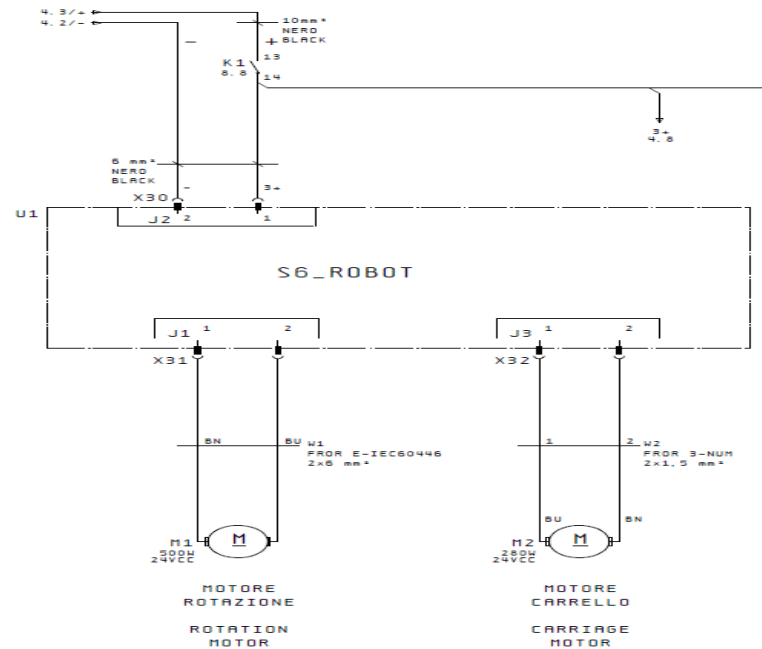

X36/J22 Connector – Pin Table description

Pin Number	Signal Description
1	CPU Supply(+)
2	CPU Supply(-)

**X37/J10 Connector – Pin Table description
(Modbus Main Board – Touch Screen)**

Pin Number	Output Description
1	RS485 - A
2	RS485 - B
3	RS485 - GND

**X38/J8 Connector – Pin Table description
(Modbus Main Board – Prestretch card) – (Modbus Main Board –Battery charges)**

Pin Number	Output description
1	RS485 - A
2	RS485 - B
3	RS485 - GND

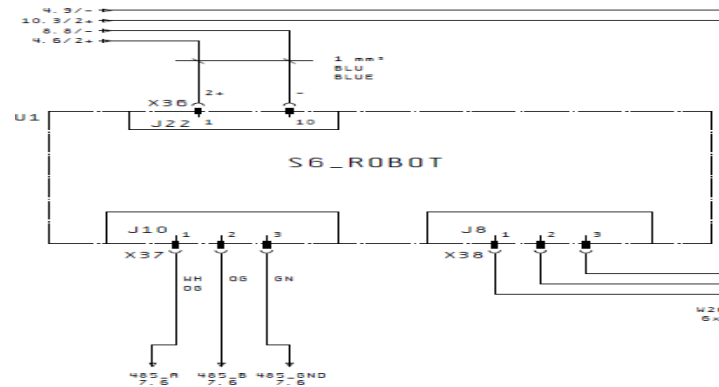

ALIMENTAZIONE CPU
CPU POWER SUPPLY

X36/J22 e X42/J23 Connectors – Input Table description

Input Number	Led Number	Input Description	Led State to Start	Contact type
In1	DL8	Emergency	OFF	N.O
In2	DL9	Start	OFF	N.O
In3	DL10	Reset	OFF	N.O
In4	DL11	Top limit switch	OFF	N.C
In5	DL12	Bottom limit switch	OFF	N.C
In6	DL13	Photocell detection product	ON	N.O
In7	DL14	Free		
In8	DL15	Counter corners sensor	OFF	N.O
In9	DL16	Emergency chain	ON	N.O
In10	DL17	Bumper emergency	OFF	N.C
In11	DL18	Manual forward	OFF	N.O
In12	DL19	Manual backward	OFF	N.O
In13	DL20	Film break (FRD-FR-FS carriages) or Film unwind push button (PVS carriage)	OFF	N.O
In14	DL21	Open alarm Rudder	OFF	N.O
In15	DL22	Free		
In16	DL23	UP/DOWN carriage motor sensor (encoder)	OFF	N.O

X43/J21 Connectors – Output Table description

Ouput Number	Led Number	Output description
Out1	DL25	Power save function
Out2	DL26	Traction brake
Out3	DL27	Film cut (Optional)
Out4	DL28	Beeper
Out5	DL29	Blinker
Out6	DL30	Roping Device Fall (Optional)
Out7	DL31	Roping Device Rise (Optional)
Out8	DL32	Brake / Clutche (Fr-Fs-Pds Carriages)

Pre-stretch Card 1 Motor (U3) - – CODE 1430300198

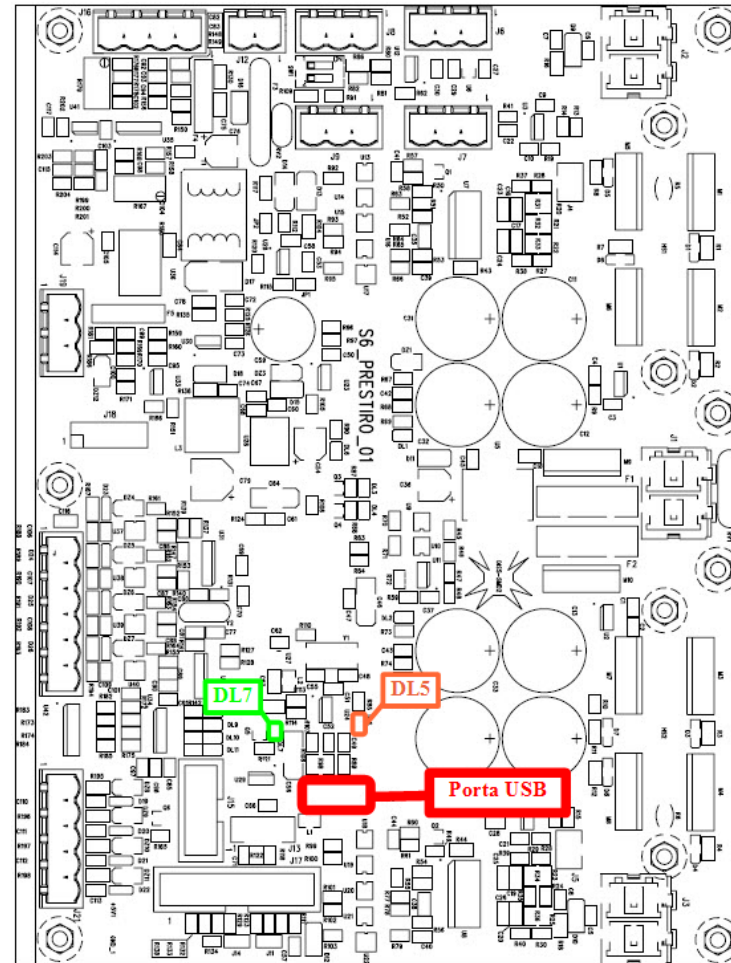

X33/J1 – Connector – Pin Table description

Pin Number	Signal Description
1	Inverter Supply(+)
2	Inverter Supply(-)

X34/J2 Connector – Pin Table description

Pin Number	Signal Description
1	M3 Command Stretch Motor
2	M3 Command Stretch Motor

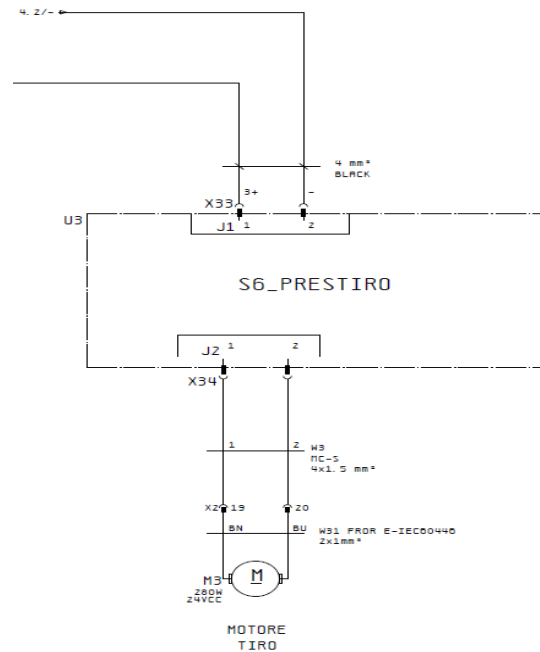

X44/J12 Connector – Pin Table description

Pin Number	Signal Description
1	CPU Supply(+)
2	CPU Supply(-)

**X39/J8 Connector – Pin Table description
(Modbus Main Board – Pre-stretch Card)**

Pin Number	Signal Description
1	RS485 - A
2	RS485 - B
3	RS485 - GND

**X40/J9 Connector – Pin Table description
(Modbus Pre-stretch Card – Battery Charger)**

Pin Number	Signal Description
1	RS485 - A
2	RS485 - B
3	RS485 - GND

**Connector X41/J16 - Pin Table description
– (Load Cell)**

Pin Number	Descrizione Output
1	12V Power Supply Load Cell (Blue)
2	Load Cell signal (+ mv) (White)
3	Load Cell signal (- mv) (Red)
4	0V Power Supply Load Cell (Black)

(Loading Cell)

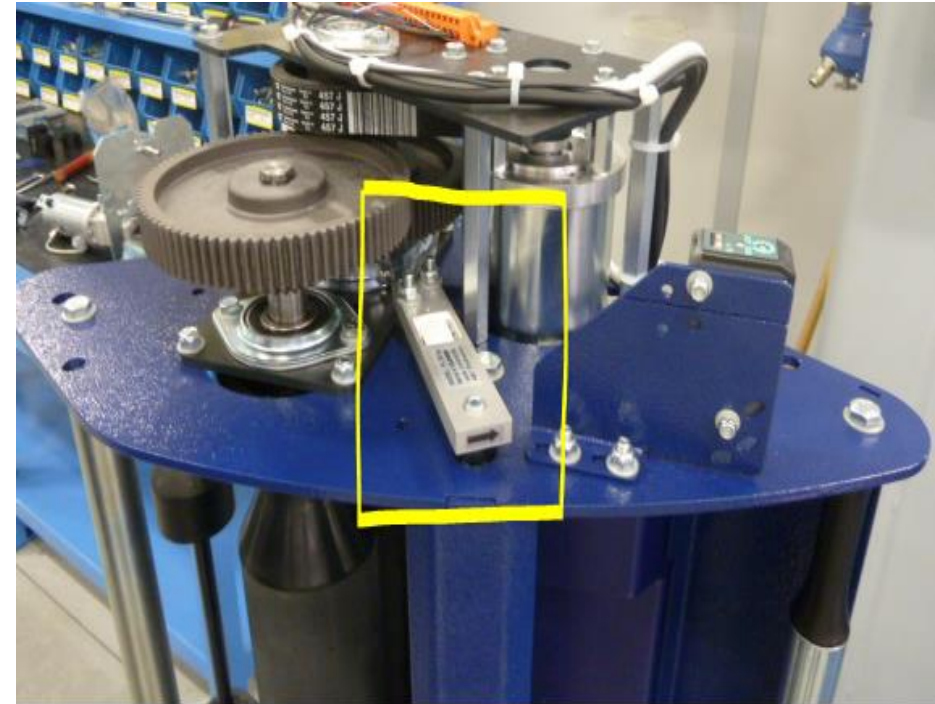
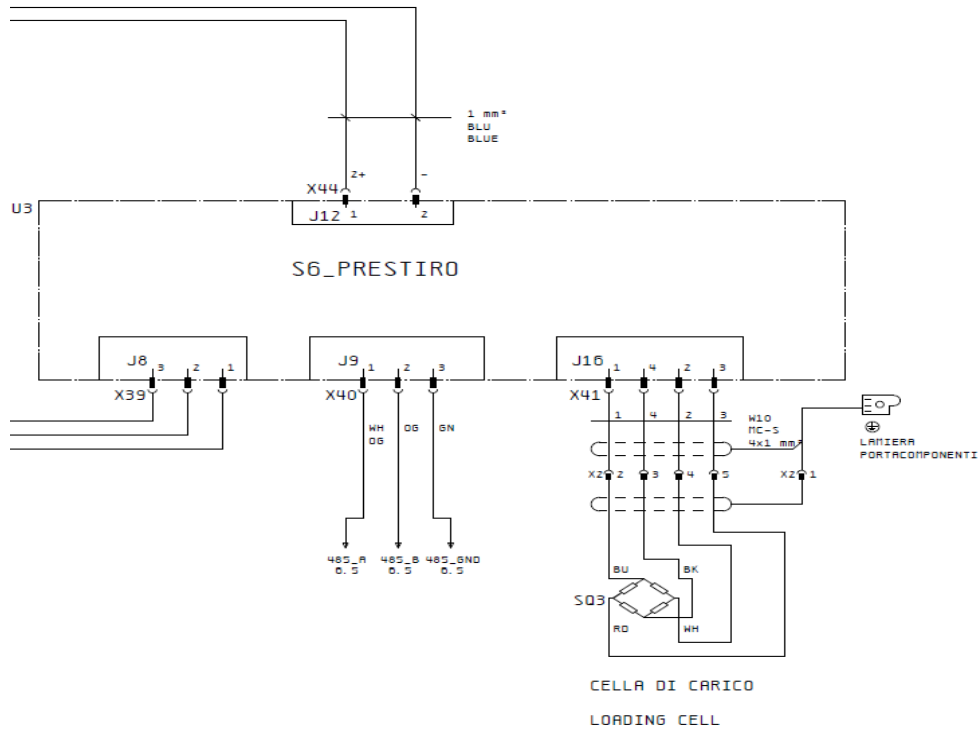

Pre-stretch Card 2 Motors (U3) - – CODE 1430300181

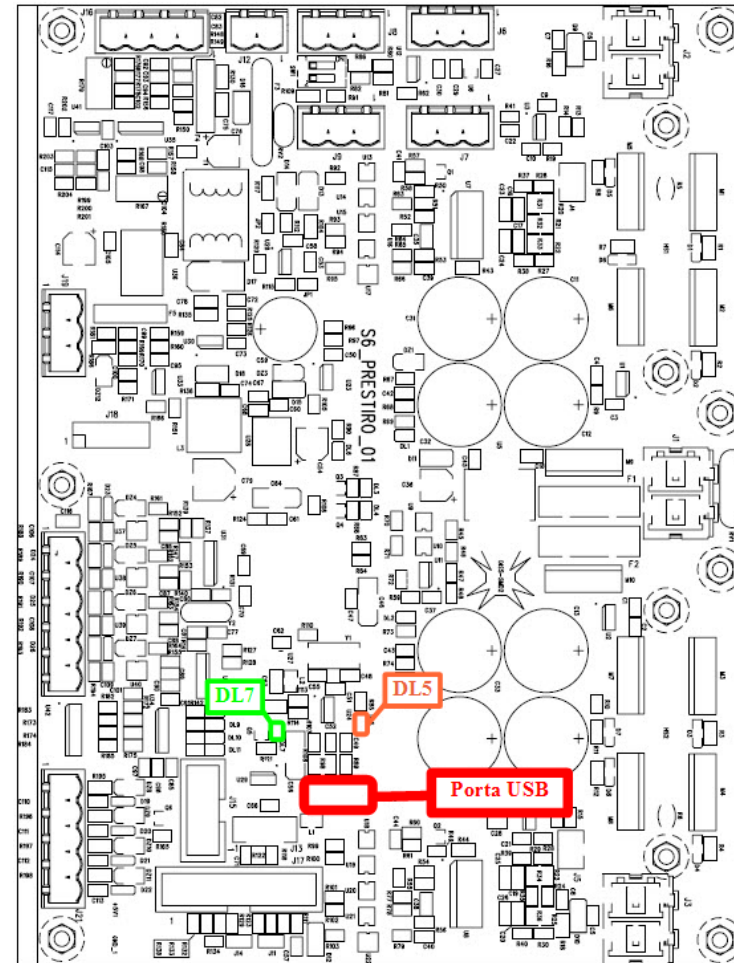

X33/J1 – Connector – Pin Table description

Pin Number	Signal Description
1	Inverter Supply(+)
2	Inverter Supply(-)

X34/J2 Connector – Pin Table description

Pin Number	Signal Description
1	M3 Command Stretch Motor (Fast Roll)
2	M3 Command Stretch Motor (Fast Roll)

X35/J3 Connector – Pin Table description

Pin Number	Signal Description
1	M4 Command Pre-Stretch Motor (Slow Roller)
2	M4 Command Pre-Stretch Motor (Slow Roller)

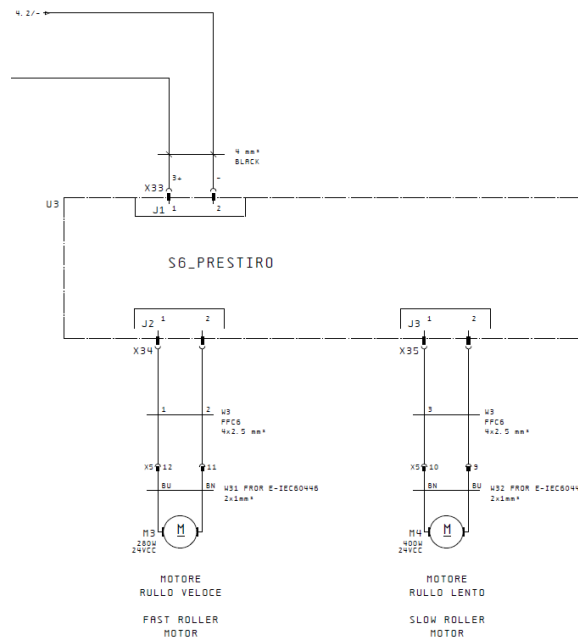

Control Roping Device Card CORD01ROB (U12) -- CODE 1430300246

Table description status signals/input/output (U12)

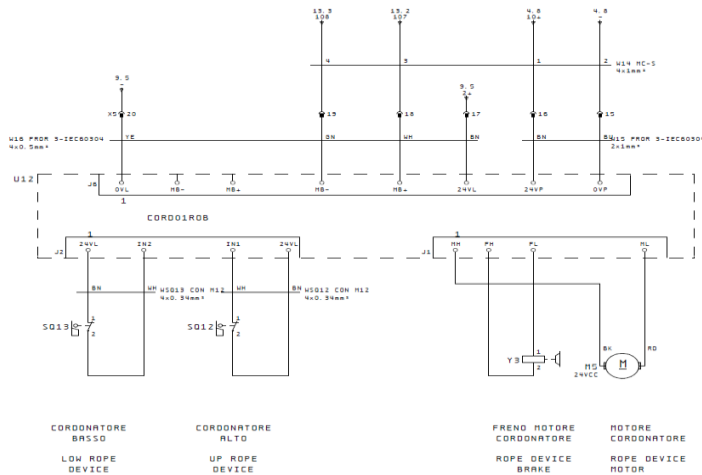
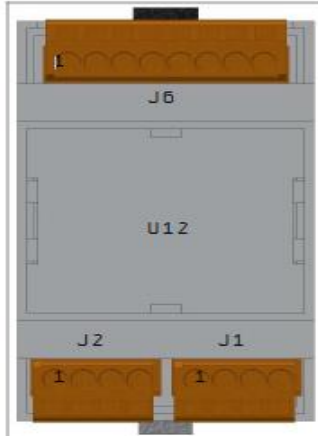

J1 Connector (Pin)	Function description	Led Status	Contact Type
MH (1)	Roping Device Motor		
FH (2)	Brake Roping Devider		
FL(3)	Brake Roping Devider		
ML (4)	Roping Device Motor		
J2 Connector (Pin)	Input Description		
+ (1)	Low Sensor Roping device		
In1(2)	Low Sensor Roping device	OFF	N.C.
In2 (3)	Up Sensor Roping device		
+ (4)	Up Sensor Roping device	OFF	N.C.
J6 Connector (Pin)	Signal Description		
0VL (1)	Supply 0VL		
MB - (2)	Not used		
MB + (3)	Not used		
MB - (4)	Roping Device Motor		
MB + (5)	Roping Device Motor		
24VL (6)	Supply 24VL		
24VP (7)	Supply 24VP		
0VP (8)	Supply 0VP		

Control Roping Device Card DCM01ROB (U12) – CODE 1430300268

Table description status signals/input/output (U12)

J1 Connector (Pin)	Function Description	Led Status	Contact Type
MH (1)	Roping Device Motor		
FL (2)	Brake Roping Devicer		
FH (3)	Brake Roping Devicer		
ML (4)	Roping Device Motor		
J2 Connector (Pin)	Input Description		
+ (1)	Up Sensor Roping device		
In1(2)	Up Sensor Roping device	OFF	N.C.
- (3)	Up Sensor Roping device		
+ (4)	Low Sensor Roping device		
In2(5)	Low Sensor Roping device	OFF	N.C.
- (6)	Low Sensor Roping device		
+ (7)	Encoder Sensor Roping device		
In3(8)	Encoder Sensor Roping device	ON	N.O.
- (9)	Encoder Sensor Roping device		
J4 Connector (Pin)	Signal Description		
0VP (1)	Supply 0VP		
24VP (2)	Supply 24VP		
24VL (3)	Supply 24VL		
MB+ (4)	RS485A (Out)		
MB- (5)	RS485B (Out)		
MB+ (6)	RS485A (In)		
MB- (7)	RS485B (In)		
0VL (8)	Supply 0VL		

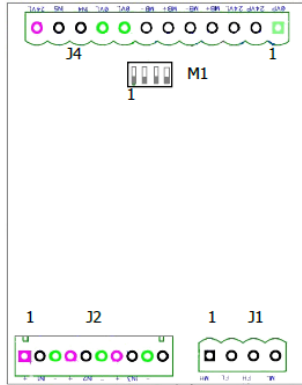

M1 Switch Configuration

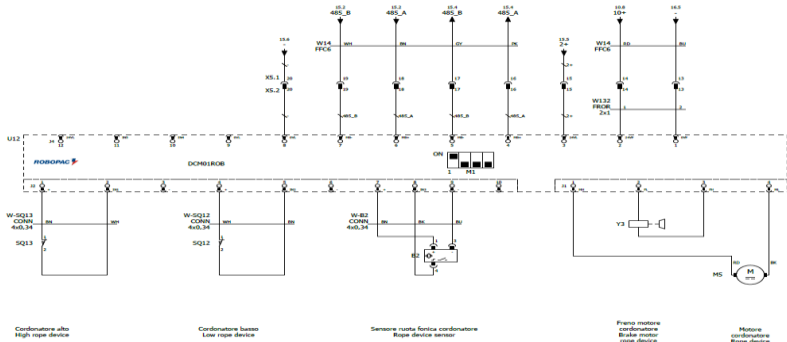

 Norm. Tecn. 60.2.49_14	TECHNICAL DOCUMENTATION - ROBOT S6 (Touch Screen Kinco Version) -	Date: October 2021	Rev.16
	ENGLISH	Pag. 27 / 113	

POWER SAVE” FUNCTION (MACHINE STAND-BY)

If the machine doesn't run for a period of 15 minutes (the machine doesn't make packing and nobody touch the operator panel) it switch to the "power save" mode. In this condition, the output relay "emergency" (so, the contactor K1 disconnects) and the touch-panel switch to stand by mode too (dark screen). To exit from this condition, it is just necessary to touch any part of the screen or the RESET push button.



“POWER SAVE” FUNCTION (MACHINE SHUTDOWN)

If other 45 minutes run after the "POWER SAVE" mode without nobody plays with the machine, it TURN OFF automatically and the white lamp of the ON/OFF push button will switch off too. To re-start the machine, it is just necessary to press the ON/OFF push button.

This function grant a longer life and better performance of the battery.

LIST OF RECIPES DATA

Parameter		Min. – Max.	Step	Unit of measure / Notes	
Type of packaging cycle		Up and Down cycle			
		Up only cycle or Down only cycle			
		Top sheet cycle			
		Packaging Cycle with automatic cutting	Option activation	ON BLUE COLOURED BUTTON	OFF GREY COLOURED BUTTON
			Option activation	ON BLUE COLOURED BUTTON	OFF GREY COLOURED BUTTON
Bottom wraps		0 – 20	1	Wraps	
Top wraps		0 – 20	1	Wraps	
Photocell delay		0 – 100	1	cm	
Ground Offset		0 – 300	1	cm	
Reinforcement height and reinforcement wraps		310 cm	0 -- 310	1	cm
		20 Hz	0 – 20	1	Wraps
Arm Rotation speed		35 – 80	1	RPM	
Carriage up/down speed			1.5 – 5.0	0.1	m/minute
			1.5 – 5.0		

Altimeter		0 – 310	1	cm
Roping Device Parameters		0 – 100	1	%
		0 - 10	1	Wraps

FRD CARRIAGE

Film Stretch– Manual adjustment				Dimensionless
---------------------------------	--	--	--	---------------

FR CARRIAGE

Film Stretch		0 – 100	1	Dimensionless
--------------	---	---------	---	---------------

FS CARRIAGE

Film pre-stretch		0 – 200	10	%
------------------	---	---------	----	---

PDS CARRIAGE

Film Stretch		0 – 100	1	Dimensionless
Film pre-stretch		0 -- 25	10	%

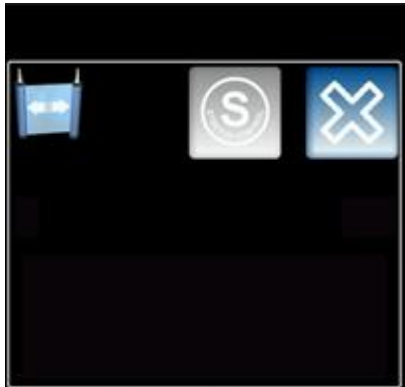

Stretch control off.

Pre-stretch is always set to maximum. The obtained pre-stretch depends on the gear ratio applied on the carriage (200% - 250% - 300%).

Standard operations includes 250% maximum applied pre-stretch.

While pressing for about 4 sec.

the icon enables the management of the shot into 4 values (Bottom wraps – Carriage up - Top wraps – Carriage down)

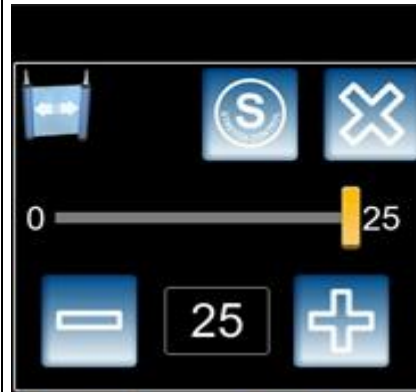
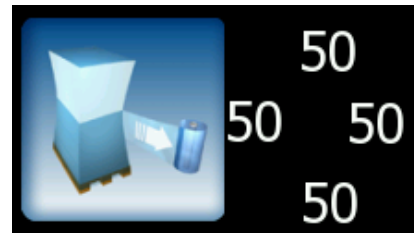

Stretch control on.

It's possible to DEACTIVATE the prestretch.

With values from 0 to 6/7/8/9

(it depends on many elements) the prestretch is DEACTIVATED, with values over that value the Prestretch is ACTIVATED

The obtained pre-stretch depends on the gear ratio applied on the carriage (200% - 250% - 300%).

Standard operations includes 250% maximum applied pre-stretch.

While pressing for about 4 sec.

the icon enables the management of the pre-stretch into 4 values (Bottom wraps – Carriage up - Top wraps – Carriage down)



PVS CARRIAGE

Film Stretch		0 – 100	1	Dimensionless
Film pre-stretch		0 -- 400	10	%



Enabling Special packaging cycles

- DISABLED FUNCTION → ICON GREY BACKGROUND.
- FUNCTION ENABLED ICON BACKGROUND BLUE



Cycle standard packing with bottom wraps at end of cycle (SPECIAL CYCLE DISABLED – icon background color gray)



Special packing cycle for huge dimensions perimetral products (CICLE DISABLED – background icon blue color)



Special packing cycle for cylindrical or smaller dimension fo minimum size 60 x 60 cm (CICLE DISABLED – background icon blue color)



Icon to view the selected packing cycle. Pressing on “+” or “-“, it is possible to scroll all the set packing cycle to run the appropriate one for the product to pack

Packing cycle for huge dimensions products (F1 cycle):



Up-ward movement value film spool carriage upon every packing round



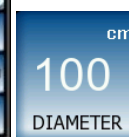



Packing cycle for cylindrical products or smaller dimension fo minimum size 60 x 60 cm (F2 cycle):



Product diameter selection for circular product, or diagonal setting for small products

 Norm. Tecn. 60.2.49_14	TECHNICAL DOCUMENTATION - ROBOT S6 (Touch Screen Kinco Version) - ENGLISH	Date: October 2021	Rev.16
		Pag. 32 / 113	

GENERAL FUNCTIONS AVAILABLE ON TOUCH-PANEL

	Enable manual functions
	Close window
	Instruments
	Information
	Back to previous page
	Back to Main page

HOW TO USE THE ACCESS PASSWORD OF THE OPERATOR TOUCH-PANEL

To apply the password by operator panel to access the required section. follow the next procedure:



By Main page (the one that appear on machine start-up), press the icon "INSTRUMENTS 



By applications page, press icon "ACCOUNT 



By account page, press icon "USER 

 till visualize on the screen the icon of the related user (please refer to below's specifications).







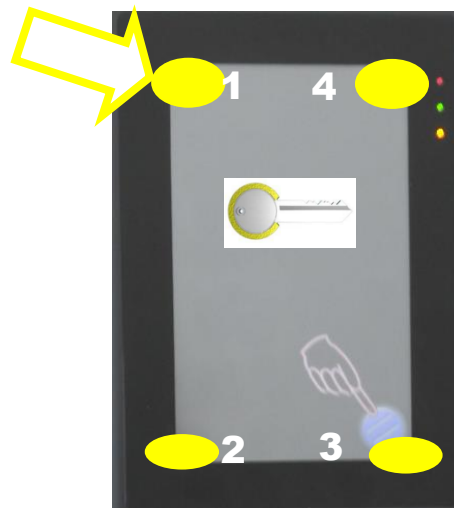



Procedure to reset the "USER ACCOUNT" password to default.

If you forget the first level password (**operator USER ACCOUNT**), it is possible to RESET it to the default (**1111**) like producer setting.

Turn the machine ON in the RESET page, and within 5 seconds, press in counter-clockwise sequence the four corners of the touch panel starting from top left corner (see below sketch). As soon the operation will be complete, the operator panel will give an acoustic signal and will display for few seconds a key that will show the default password (**1111**) as shown in below sketch.



When the key with password **1111** is displayed on the touch panel, you'll be sure that the password has been reset to DEFAULT.

MACHINE USER CUSTOMER SELECTION	  <p>No access password to higher use levels. Touch-screen operator panel locked..</p>	 <p>Machine use for packaging.</p>
	  <p>CUSTOMER USER (Machine manager/User) Enter password = 1111</p>	
<p>Utilizzo della macchina limitato alla impostazione dei valori di ciclo ed impostazione di una diversa password di accesso.</p>		
ROBOPAC DEALER SECTION	  <p>MAINTENANCE TECHNICIAN USER (Robopac dealer) Password = 6161</p>	 <p>Maintenance technician password accepted confirmation.</p>
<p>Possibilità di utilizzo della macchina come “Utente cliente” ed accesso alle funzioni ed alla diagnostica per la manutenzione.</p>		
ROBOPAC SECTION	 <p>ROBOPAC TECHNICIAN USER For exclusive ROBOPAC technician use</p>	 <p>ROBOPAC technician password accepted confirmation.</p>

MACHINE'S END-USER SECTION

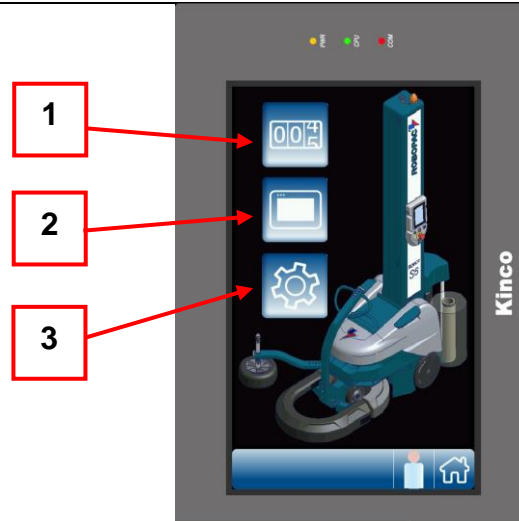

**OPERATOR'S TOUCH-PANEL
GENERAL SETTINGS
FUNCTIONS**

Active functions without password inserted



Packed product counter display (production control)

RESETTING VALUES NOT POSSIBLE

Active functions with password inserted



Inserting the password **1111**, it is possible to reset the partial packing counter (production control).



View of:

- Softwares installed on the machine
- Touch panel locked / un-locked
- Operator panel language set
- Date / time
- Acoustic signal buttons on operator panel ON / OFF
- IP ADDRESS

2

- SW Release touch screen (HMI)
- SW Release main board (PLC)
- SW Release Pre-stretch card (when installed)
- SW Release Roping Device when installed)
- Main Board board serial number (PLC)
- Pre-stretch card serial number (when installed)

Versione FW touch-screen

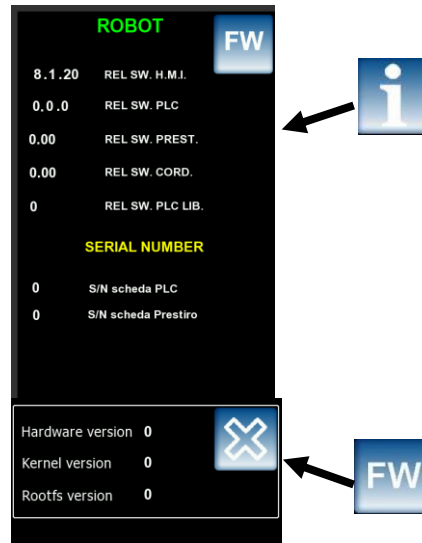

Inserting the password **1111** it is possible to modify the following settings:



Touch-panl locking / Un- locking

Un-locked - Locked



Touch panel language setting



Time / Date setting

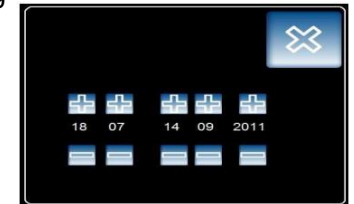

h m dd mm yyyy



Acoustic signal buttons on operator panel ON / OFF



First level password modification only



View of:

- Level battery status
- Alarm history
- Internal parameter list
- I / O (input / output) conditions
- State / condition ModBus protocol
- Monitoring Stretch – Pre-Stretch
- Download software Upgrade Panel

(Spe)

MODIFICATION NOT POSSIBLE

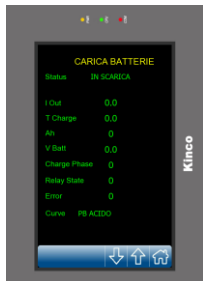

3



Alarm history page



Internal parameter list page

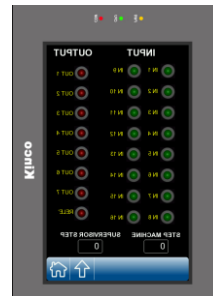

I / O (input / output state) pane

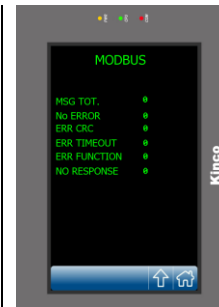

- State / condition ModBus protocol - page



For instant monitoring page of Stretch and Pre-Stretch values

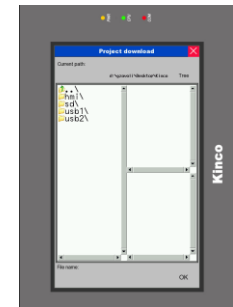

Page to download software to upgrade panel commands

(NordElettronica)



Level battery status page

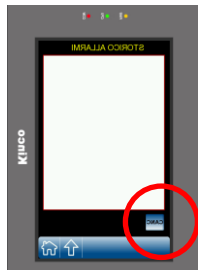

By setting the password, you can delete the list of alarm history by pressing the

button

Active functions with operator touch panel locked



Active functions with Operator touch panel unlocked



AVAILABLE FUNCTIONS ON OPERATOR TOUCH PANEL IN LOCKED OR UNLOCKED MODE

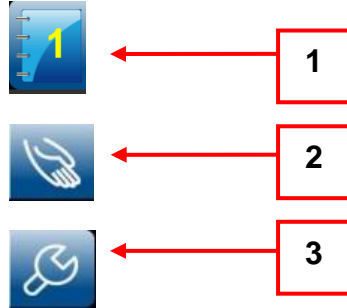

1



Press this icon to access the set packing programs (refer to sketch on side of the recipes).
On each packing program, it is possible to set all the cycle values desired



Recipes lists to set packing programs

Packing cycle set on the selected recipes

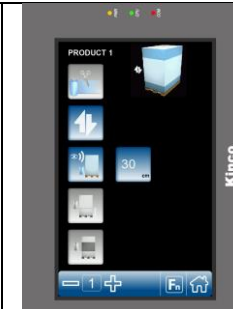

Details of the packing cycle values set (packing) suitable for each product (recipe)

2

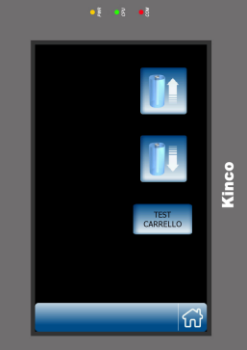

Manual carriage up-ward



Manual carriage down-ward

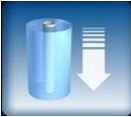

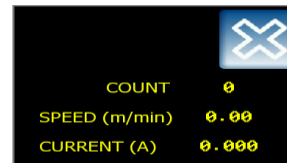

Function to enable the test of film spool carriage speed



Window which shows the speed of film spool carriage (mt/min)

3		<p>Press this icon to go back to the main page to access machine's internal parameter</p>	
---	--	---	--

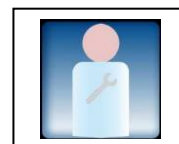
MANUAL functions on the Roping with service password



- during the movement of the motor, the value "COUNT" has to change from 0 and the value stored in P28 (default:210) and the movement speed has to be about 17÷20 cm/min.
- The current "I MOTOR" has not to exceed the 2A.
Nominal value: about 1.1A (down), 1.5A (up) 0.15A (standing still).
- The current "I FRENO" has to be about 0.5÷0.6A with the motor running and 0.02A with the motor standing still.
- The value "Vin SCHEDA" show the input card voltage, about 24.6V

CORDONATORE

STOP	STATO
0	COUNT
0	SPEED (cm/sec)
0.00	I MOTORE (A)
0.00	I FRENO (A)
0.0	Vin SCHEDA (V)
0.00	SW Release

PACKING PARAMETER SETTING

(modifiable when operator touch panel UNLOCKED only)

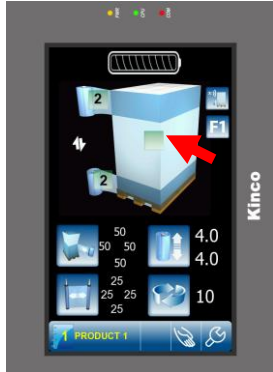

To access the cycle parameters section, press the center of the icon which shows the pallet.



Up / Down packing cycle
Alternating packing cycle (up-ward only / down-ward only)
Top sheet cycle

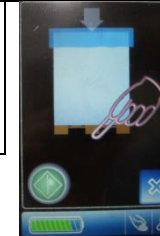

Indication to re-start the cycle after top application above the product



Film automatic cutting (blue = ENABLED / grey = DISABLED)



Film automatic cutting (blue = ENABLED / grey = DISABLED)



Roping device (blue = ENABLED / grey = DISABLED)

Packing cycle parameters description

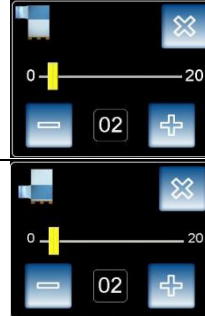
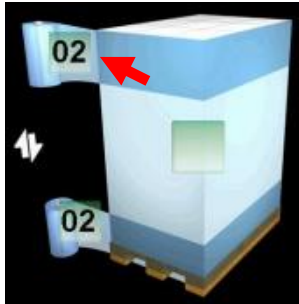

Press on the icon of the touch-panel in the section shown with the red arrow, it is possible to enable the function to set the number of top over-wraps (pressing in the bottom position it is possible to set the number of bottom over-wraps) during the packing cycle.



Icon to adjust FILM STRETCH (display on machines equipped of FR/PDS/PVS film carriage only)

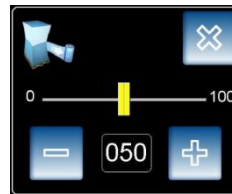

Window to set the film tension (stretch)



Windows to set multiple film stretch (bottom wraps / top wraps / upward carriage / downward carriage) enabling by keeping pressed the icon  for about 4 seconds



Icona to adjust the UP / DOWN FILM SPOOL CARRIAGE SPEED.



Page to set the film carriage speed (up-ward and down-ward)

	<p>Icon to adjust FILM PRE-STRETCH (display on machines equipped of FS/PDS/PVS film carriage only)</p>	<p>Selection for fix pre-stretch or variable pre-stretch</p>	<p>Variable pre-stretch setting window (adimensional values)</p> <p>Windows to set multiple film pre-stretch (bottom wraps / top wraps / upward carriage / downward carriage) enabling by keeping pressed the icon for about 4 seconds</p>
	<p>Icon to adjust machine's TRACTION SPEED</p>		<p>Window to set the speed of the machine (mt/min)</p>
	<p>Icon PHOTOCELL DELAY</p>	<p>Pressing these icons, it is possible to switch to packing cycle with photocell delay setting to packing cycle with altimeter</p>	<p>Press on these icons to set the desired photocell delay setting to adjust the film overlap on top of pallet</p>
	<p>Icon ALTIMETER</p>		<p>Press these icons to set the maximum desired high that film spool carriage has to reach (photocell excluded) like altimeter setting</p>
	<p>Offset from ground. (NOT ENABLED)</p>	<p>Offset from ground (ENABLED))</p>	<p>Press these icons to set the offset from ground value (to pack starting from a different level then ground)</p>
	<p>High and reinforcement wraps number (NOT ENABLED)</p>	<p>High and reinforcement wraps number (ENABLED)</p>	<p>Press these icons to set the level from ground and the number of reinforcement wraps to perform on</p>



Special packing cycles selection:

- DISABLED FUNCTION → GREY BACKGROUND ICON.
- ENABLED FUNCTION → BLUE BACKGROUND ICON



Standard packing cycle
(CICLE DISABLED – background icon grey color)



Special packing cycle for huge dimensions perimetral products
(CICLE DISABLED – background icon blue color)



Special packing cycle for cylindrical or smaller dimension fo minimum size 60 x 60 cm (CICLE DISABLED – background icon blue color)

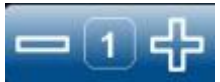

Icon to view the selected packing cycle. Pressing on “+” or “-”, it is possible to scroll all the set packing cycle to run the appropriate one for the product to pack.

Packing cycle for huge dimensions products (F1 cycle):



Up-ward movement value film spool carriage upon every packing round

Packing cycle for cylindrical products or smaller dimension fo minimum size 60 x 60 cm (F2 cycle):

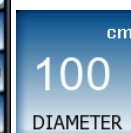
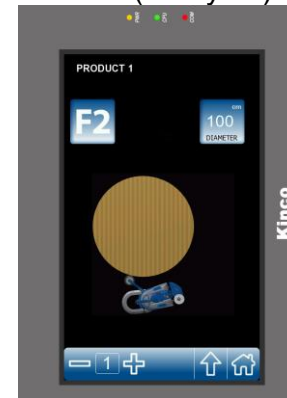

Product diameter selection for circular product, or diagonal setting for small products

Packing cycle setting recording:



Press on recipe icon access



Press on name of the recipe to store the new packing cycle setting and re-name



Using the alphanumeric keyboard to insert or rename the recipe (packing program)



BATTERY TEST CONDITION FUNCTION

(this function is available when the operator touch panel is locked)



Pressing the icon “battery status” on the pages where it is shown, it opens the windows shown on the side, where it is shown the voltage given by the battery measured by the mother-board of the machine. Check the battery voltage and compare it with the voltage got by the multi-tester instrument. Tolerance $\pm 0,1V$



MANUAL FORWARD SPEED ADJUSTMENT FUNCTION

It is possible to adjust the forward speed of the machine in manual mode. Keeping pressed the push button of **manual forward** and then, pressing the push button of **manual backward**, will be possible to increase the manual forward speed of the machine. For each press of the **manual backward** push button, the speed will be increased of one “step” till reaching six increased speeds. Releasing the manual forward push button, at next manual run, the speed of the machine will be restored to the minimum speed forward. This function is available to adjust the forward speed, not the backward speed.

 Norm. Tecn. 60.2.49_14	TECHNICAL DOCUMENTATION - ROBOT S6 (Touch Screen Kinco Version) -	Date: October 2021	Rev.16
ENGLISH		Pag. 46 / 113	

SERVICE SECTION (MACCHINE MAINTENANCE)



All the functions described in the paragraph **“MACHINE’S END-USER SECTION”** can be used by serviceman (distributor engineer) using his **6161**.

INTRODUCTION:

In case of replacement of the touch-panel, mother-board or pre-stretch card, or in case of software updating of one of the three cards mentioned above, it will be necessary to download the new software on all the three cards (please refer to below procedure). The original machine’s software of the three cards, made during machine’s internal testing before shipment, are included into a flash memory USB bagged into the technical envelope together the technical documentation of the machine inside the battery lodge.



PROCEDURE FOR REPLACING, LOADING SOFTWARE AND CALIBRATION OF ELECTRONIC CARDS

TOUCH SCREEN PANEL (U2)

In case you need to perform a software update on both touch screen panel (HMI) and the PLC card, you must always start from the download of the panel software.



New installation MT4414TE-RO KINCO --- till January 2021 Code : 1490300020

The new Touch Screen panel is supplied as a spare part WITHOUT software

- Mount mechanically the new touch-screen panel in place of the faulty part.
- Wire electrically the new touch-screen panel.
- Set the dip switches 1 and 2 to ON to enable the Setup Mode

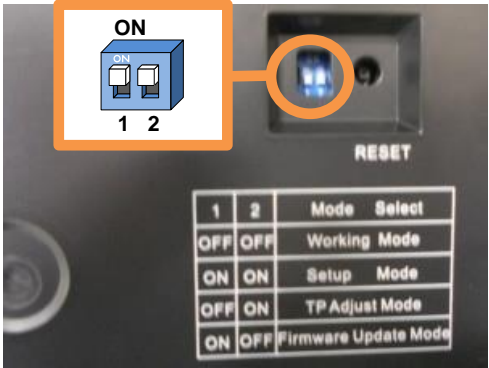

- Use the USB pen drive containing the original software versions which is supplied with the machine.



Robopac provides the original machine software with the USB 2.0 pen drive housed in the switchboard with all the technical machine documentation.

N.B.: In case it's necessary to create a new installation support (e.g: the original pen drive is lost) with a commercial pen drive:

- use a USB 2.0 pen drive only
- copy the PLC board software files provided by Robopac at first directory level of pen drive

- Insert the USB pen drive containing the original software version (file named **ROBOT_S6.pkg**) into USB plug (USB HOST) of the touch-screen panel



- **Turn on the machine**

(Old bootloader Kinco Panel)

On the HMI screen, press the “USB/SD → HMI” button to open the file manager:

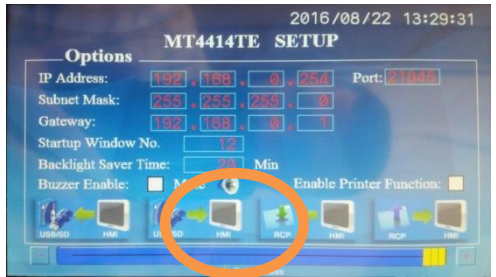

(Kinko HMI panel with NEW bootloader)

On the HMI screen, press  button to open the System Setting.

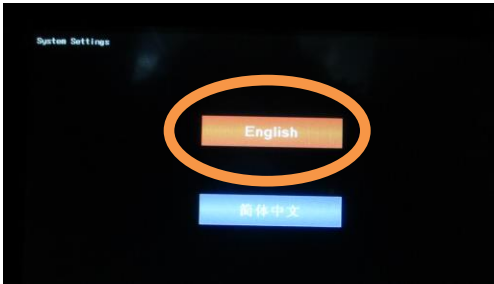

From the System Setting page, press the button

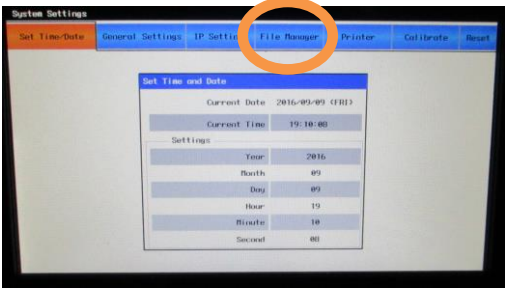

From the File Manager page, press the button to open the page copy of the file:

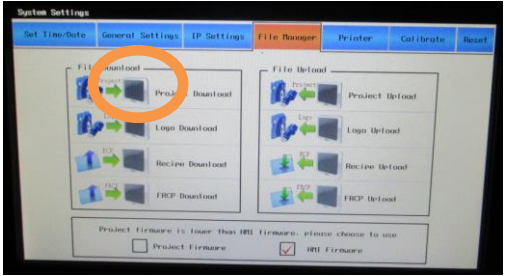
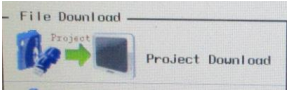

On the left screen side, press 'usb1 /'.

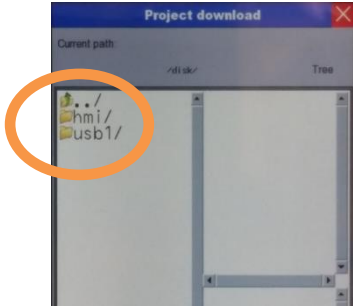

On the right screen side, select the file "ROBOT_S6.pkg."

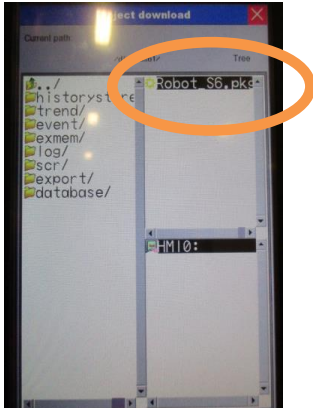

Press the OK button

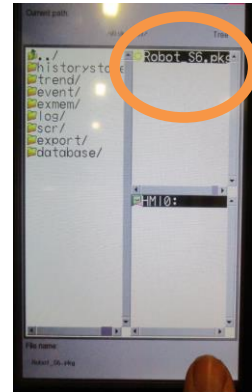

Wait for the end of the procedure

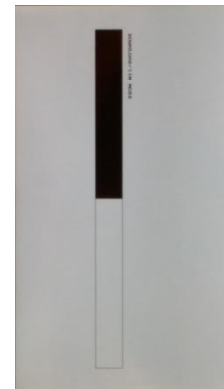

If at the end of the procedure the following messages appear loading has failed and must repeat the procedure as if you were installing a new panel.

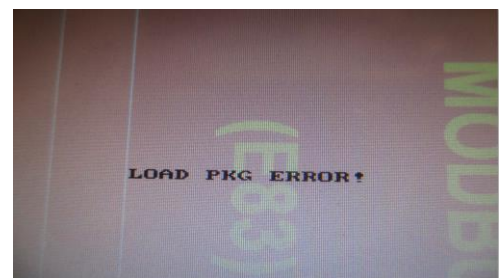
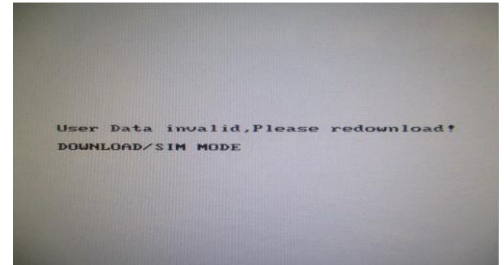

If at the end of the procedure the following message loading was successful

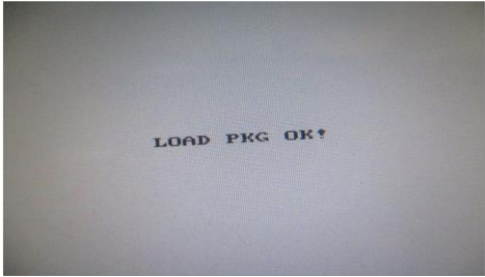

If the panel is not initialized (update of previous software release) the warning page shown aside could appear. In this case, press the "INITIALIZE" button (at the lower right corner) to initialize the HMI, then turn off and on the machine. The warning window should no longer appear (HMI correctly initialized).

If the warning window doesn't appear, go ahead and press the RESET button.

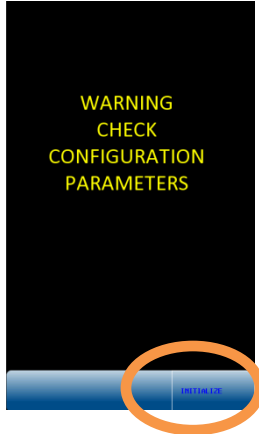

The software installation procedure is now complete.

- Turn off the machine
- Enable the Working Mode by putting the dip switches 1 and 2 to OFF.
- Remove the USB pen

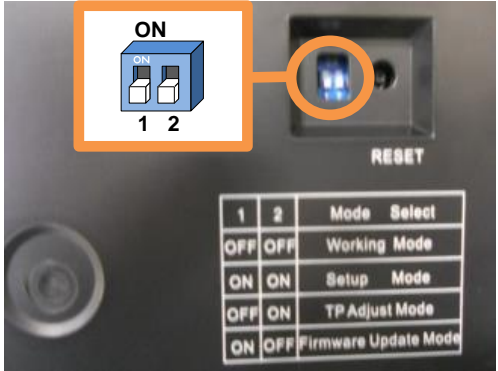

It's now necessary to run the **Default Parameters** and configuration of machine parameters and **Default Recipes** (see procedures) to fully restore the machine operation.

 Norm. Tecn. 60.2.49_14	TECHNICAL DOCUMENTATION - ROBOT S6 (Touch Screen Kinco Version) -	Date: October 2021	Rev.16
	ENGLISH	Pag. 52 / 113	

New installation K-GL070E-RO KINCO --- since January 2021

Code : 1490300034

The new Touch Screen panel is supplied as a spare part WITHOUT software

- Mount mechanically the new touch-screen panel in place of the faulty part.
- Wire electrically the new touch-screen panel.

Install the touch-screen panel software by following this procedure:

Retrieve the USB pen drive containing the original software versions which is supplied with the machine.



Robopac provides the original machine software with the USB 2.0 pen drive housed in the switchboard with all the technical machine documentation.

N.B.: In case it's necessary to create a new installation support (e.g: the original pen drive is lost) with a commercial pen drive:

- use a USB 2.0 pen drive only
- copy the PLC board software files provided by Robopac at first directory level of pen drive

Insert the USB pen drive containing the original software version (file named ROBOT_S6.pkg) into USB plug (USB HOST) of the touch-screen panel



 Norm. Tecn. 60.2.49_14	TECHNICAL DOCUMENTATION - ROBOT S6 (Touch Screen Kinco Version) -	Date: October 2021	Rev.16
	ENGLISH	Pag. 53 / 113	

Switch on the machine

THE DOWNLOAD PROCEDURE IS AUTOMATIC

Wait for the end of the procedure

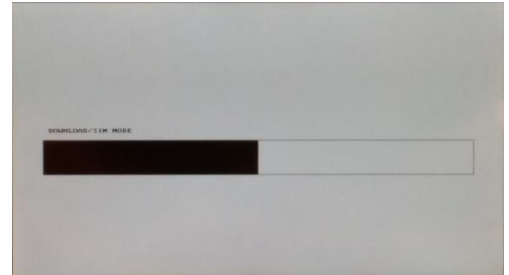

If at the end of the procedure the following messages appear loading has failed and must repeat the procedure as if you were installing a new panel.

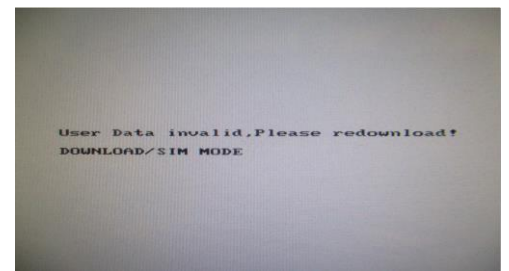

If at the end of the procedure the following message loading was successful

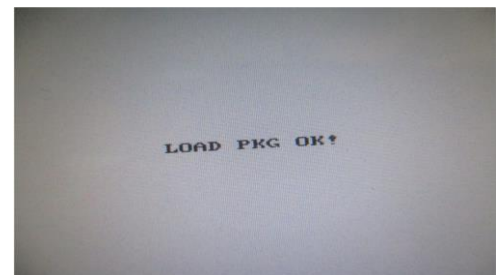

If the panel is not initialized (update of previous software release) the warning page shown aside could appear. In this case, press the "INITIALIZE" button (at the lower right corner) to initialize the HMI, then turn off and on the machine. The warning window should no longer appear (HMI correctly initialized).
 If the warning window doesn't appear, go ahead and press the RESET button.

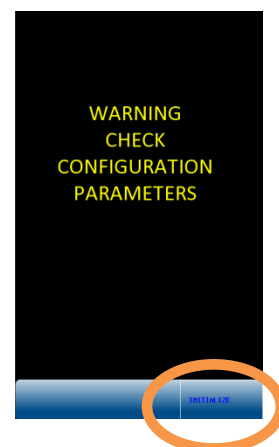

The software installation procedure is now complete.

It's now necessary to run the **Default Parameters** and configuration of machine parameters and **Default Recipes** (see procedures) to fully restore the machine operation.

ROBOPAC Norm. Tecn. 60.2.49_14	TECHNICAL DOCUMENTATION - ROBOT S6 (Touch Screen Kinco Version) -	Date: October 2021	Rev.16
	ENGLISH	Pag. 54 / 113	

Software update

With the machine **switched off**, insert the USB pen drive containing the updated version of the panel software (file name: “**ROBOT_S6.pkg**”) into the USB port (“USB HOST”) of the touch-screen panel..

Turn on the machine



On startup screen, press the “Configuration” button:



On Configuration page, press the “Service” button:



On Service page, press the “Download”  button to open the file manager:



On the file manager left panel, press “usb1”.

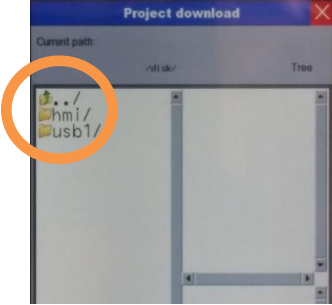

On the file manager right panel, select the file **ROBOT_S6.pkg**”.

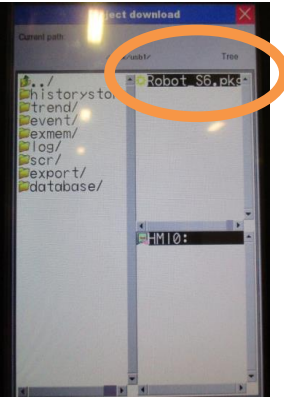

Press the “OK” button and wait until the software update ends.

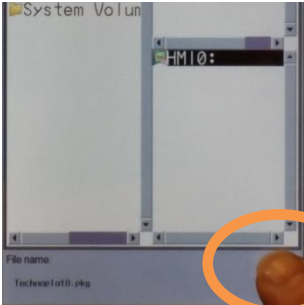

When loading ends, a communication error page could appear.
Switch off and on the machine to reinitialize the communication and cancel the error.

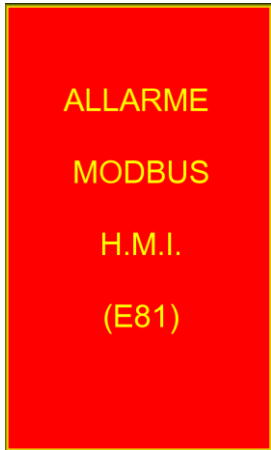

If the panel is not initialized (update of previous software release) the warning page shown aside could appear. In this case, press the "INITIALIZE" button (at the lower right corner) to initialize the HMI, then turn off and on the machine. The warning window should no longer appear (HMI correctly initialized).

If the warning window doesn't appear, go ahead and press the RESET button.

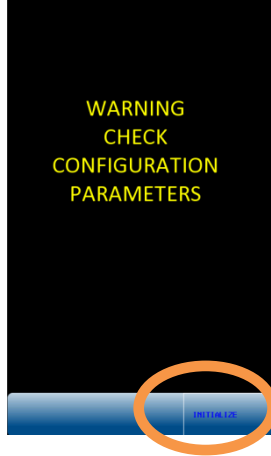

- Turn off the machine
- Remove the USB key

It's now necessary to run the **Default Parameters** and configuration of machine parameters and **Default Recipes** (see procedures) to fully restore the machine operation.

Default Parameters and re-configuration of machine parameters

After the software installation on touch screen panel (USB HOST), it's necessary to execute the "Machine Parameters Default" by following this procedure:

On startup screen press the Configuration button



On Configuration page press the user password selection button.

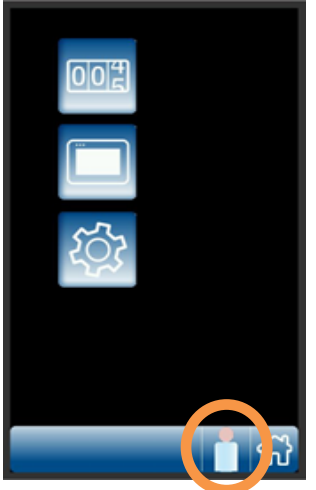

Select the "maintenance technician" user level by pressing the user icon



until the icon



appears.



Now, on the onscreen keyboard enter the password **6161**, then press **ENTER**.



If the password is correctly entered and accepted, the Configuration page returns, with the “maintenance technician” icon on the bottom status bar.



Press now the Service button:

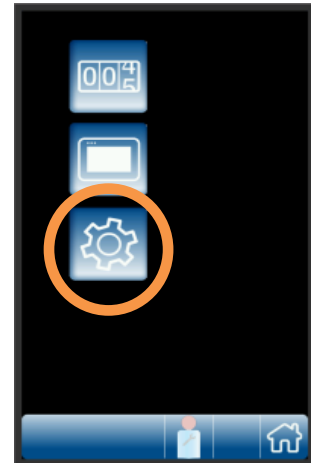

On “Service” page, press the “PARAM” button to enter the Page 1 of Machine Parameters.





Press the button to start the procedure for setting all machine parameters with their default values.

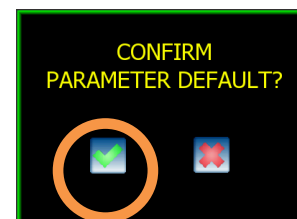

Confirm with the green button to complete the **Parameters Default** procedure. In this way, the Parameters Default is performed.

Press the red button to abort the **Parameters Default** procedure.





Depending on machine configuration, use the  and  buttons to modify the appropriate parameter values.

The new parameter value is automatically saved.

The Info button  shows the various parameters name.

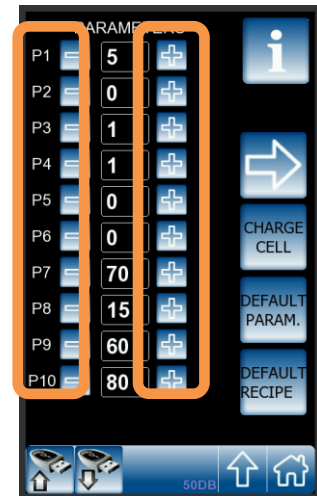
Press the  button to change the parameters page.



 Norm. Tecn. 60.2.49_14	TECHNICAL DOCUMENTATION - ROBOT S6 (Touch Screen Kinco Version) -	Date: October 2021	Rev.16
	ENGLISH	Pag. 60 / 113	

Recipes Default

After the Parameters Default procedure, or to reinitialize all work program recipes, it's necessary to perform the Recipes Default procedure in the following way:

Press the “RECIPE DEFAULT”  button to start the procedure for setting all work program recipes with their default values

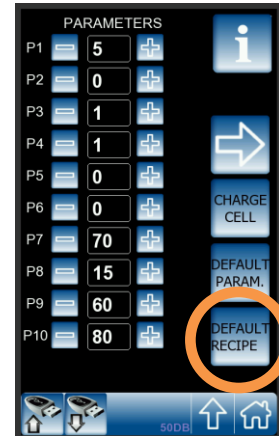

Confirm with the green button  to complete the **Recipe Default** procedure. In this way, the Recipes Default is performed.

Press the red button  to abort the **Recipe Default** procedure.

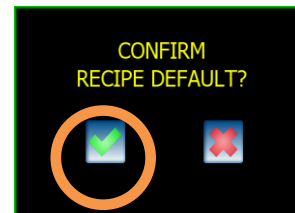

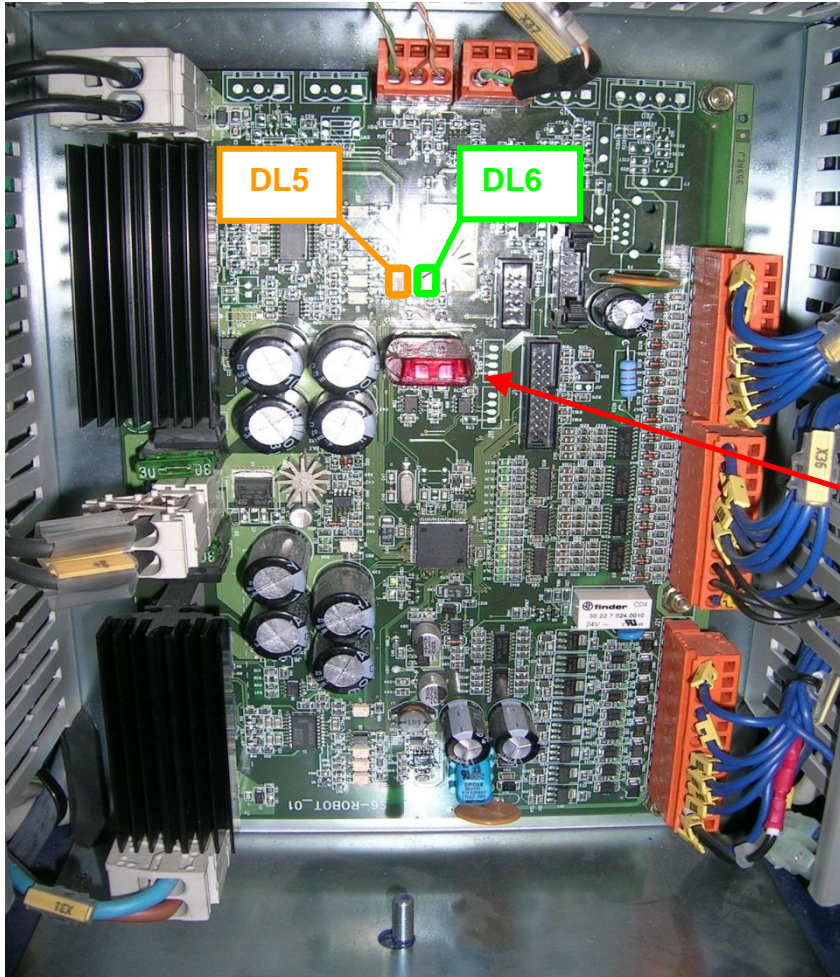
MOTHER-BOARD (U1) SOFTWARE DOWNLOAD PROCEDURE

1. **Turn the machine OFF.**
2. Insert the USB pen-drive into the (J10) port
3. **Turn the machine ON.**
The LD5 orange led will blinks advising that the software is downloading into the mother-board (refer to sketch on the side).
As soon the download will be completed, the orange led LD5 will become OFF, and the green led LD6 starts to blink advising that the new software is running.
Turn the machine OFF.
4. Remove the USB pen drive from the slot of the card.
5. **Turn the machine ON to run for working**

SLOT USB (J10)

N.B.: The electronic card is always supplied without any software.
In case of replacement of the mother-board, you got to download the software of the card following the above indicate procedure.

AMPLIFIER CARD / PRE-STRETCH MOTOR INVERTER (U3) SOFTWARE DOWNLOAD PROCEDURE

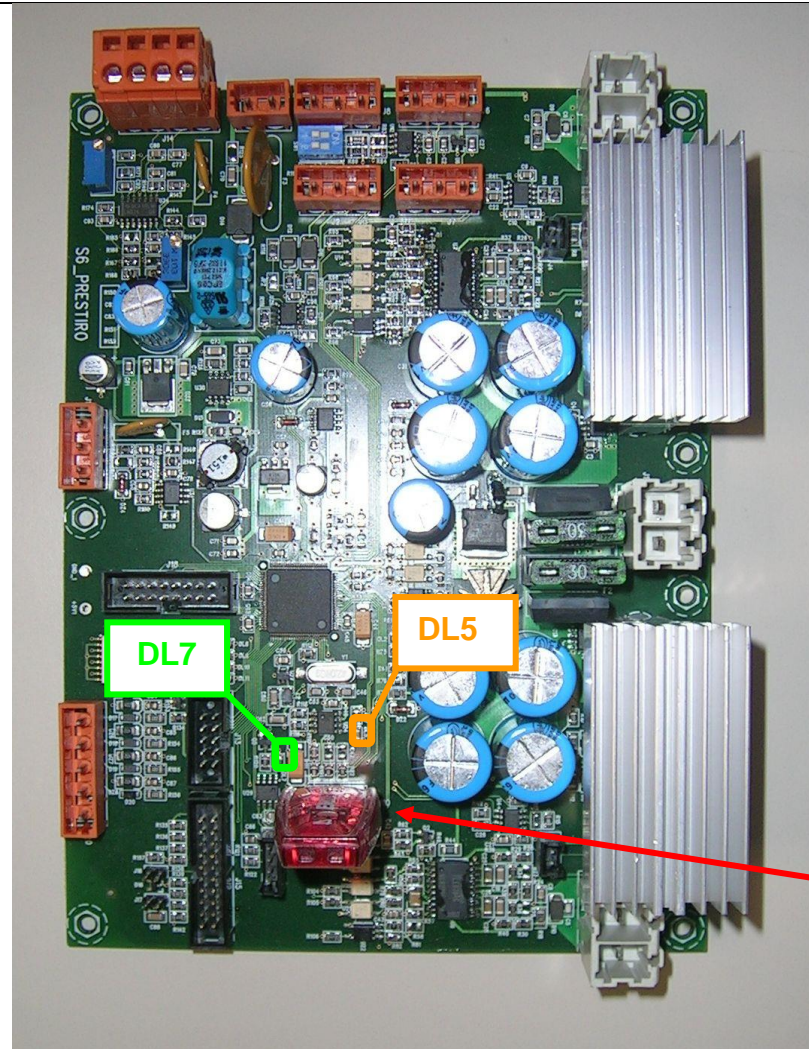

J10 USB port
connection to download
the software into the
machine's
amplificatore /inverter
card

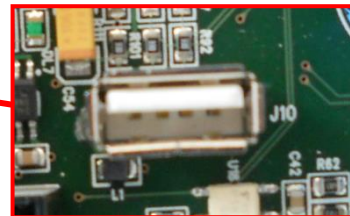

1. **Turn the machine OFF.**
2. Insert the USB pen-drive into the (J10) port
3. **Turn the machine ON.**
The LD5 orange led will blinks advising that the software is downloading into the mother-board (refer to sketch on the side).
As soon the download will be completed, the orange led LD5 will become OFF, and the green led LD7 starts to blink advising that the new software is running.
4. **Turn the machine OFF.**
5. **Turn the machine ON to run for working**

N.B.: The electronic card is always supplied without any software.
In case of replacement of the mother-board, you got to download the software of the card following the above indicate procedure.

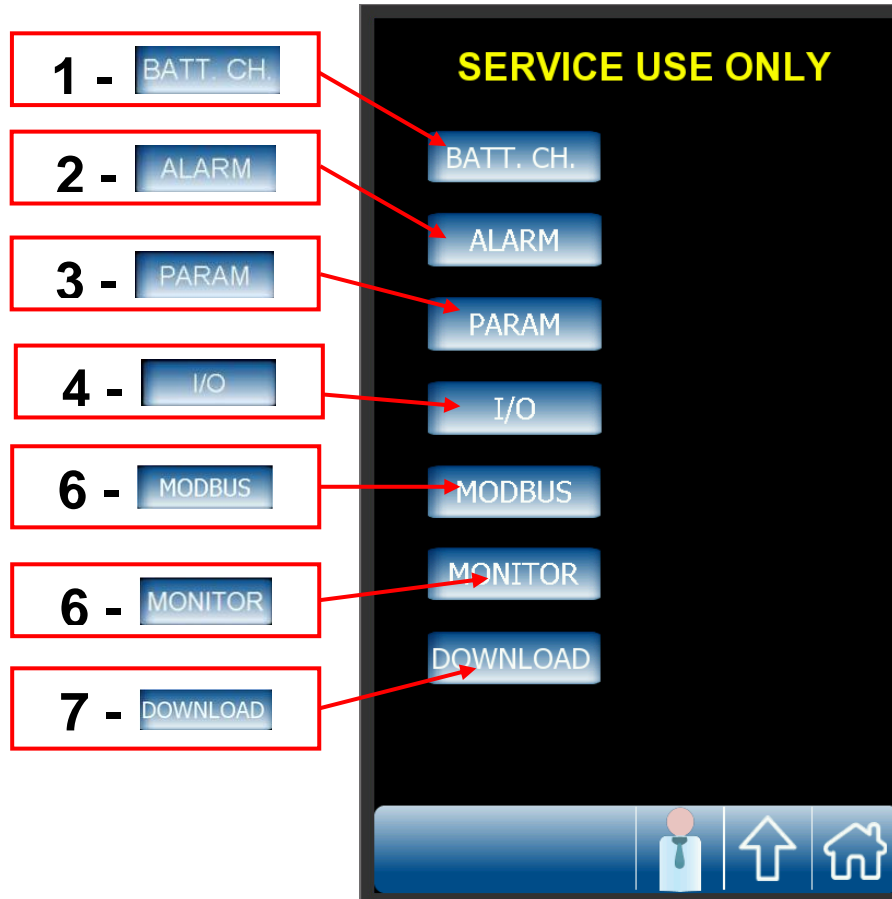
MACHINE SETTINGS AND FUNCTIONS
(modifiable by password 6161 inserted only)

1

BATTERY AND BATTERY CHARGER SETTING (SPE Model)

The machine can be equipped with “acido” battery type or “gel” battery type. The battery charger is suitable to charge both type next procedure:

1. Press the icon “settings” to access the SERVICE page (refer to above sketch).
2. Press the icon to access the **page** of battery and battery charger setting.
3. Press the icon to open the selection menu:



Access the drop down menus to select the type of battery



Select from the menu the battery fitted on the machine to determine the charge curve of the battery charger

4. Upon selection made press on the icon .
5. Close the window pressing the icon .

The charge “Curve” is displayed by the parameter “**Curve**”.

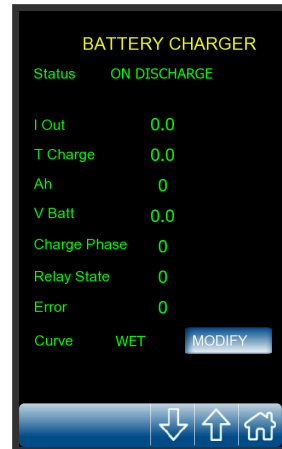
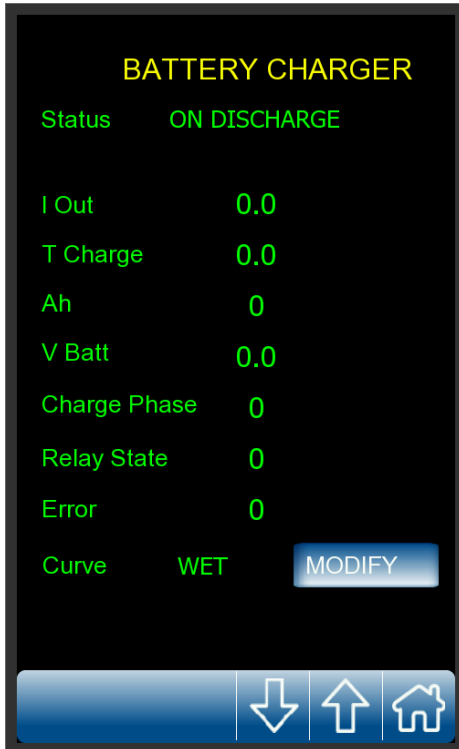

Status = working status

Iout = out-feed battery voltage

Tcharge = charge time

Ah = amper/hour charged

Vbatt = battery voltage

Charge Phase = re-charge cycle running

Relay state = relay status into battery charger

Error = error code

Current supplied by battery charger check during charge phase

Connecting the battery charger to the source, during the first minutes the supplied current from battery charger will be 11A ±0,5.

Then, checking the parameter Iout = 11A ±0,5 to check the appropriate function of the battery charger.

Press the icon  to access the page showing the report of the last 5 charges made.

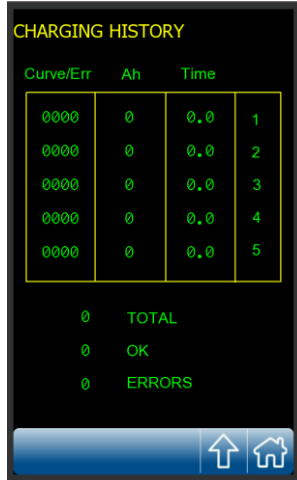

Curve/Err	Ah	Time	
0000	0	0.0	1
0000	0	0.0	2
0000	0	0.0	3
0000	0	0.0	4
0000	0	0.0	5

0 TOTAL
0 OK
0 ERRORS

CurveErr = Error code (see table below)

Ah = Total current charge

Time = Total charge time

TOTAL = Total number of charges made

OK = Number of charges done with positive result

ERRORS = Number of charges carried out with negative results

<u>Error-code</u>	<u>SPE-code</u>	<u>Description</u>
0	---	No-error
1	E01	Max-voltage
2	E02	Thermal-Cut-Off
3	E03	Time-Phase-Overflow
4	E03_1	Phase-1-Overflow
5	E03_2	Sulphation-(Phase-2-Overflow)
6	EDV	Dv/dt-Error
7	EDI	Di/dt-Error
8	Srt	Internal-Short-Circuit
9	Sct	Security-timer
10	Openmos	Broken-Mofset-(Opening)
11	OPC	Connect-Battery-(Open-circuit)
12	Power-module-fault	Module-Error-(ex.-Broken-Module-1)
---	----	----
240	0xF0	Polarity-inverion-/no-Battery
241	0xF1	Stop-Charging
255	0xFF	Error-(Generic)

1

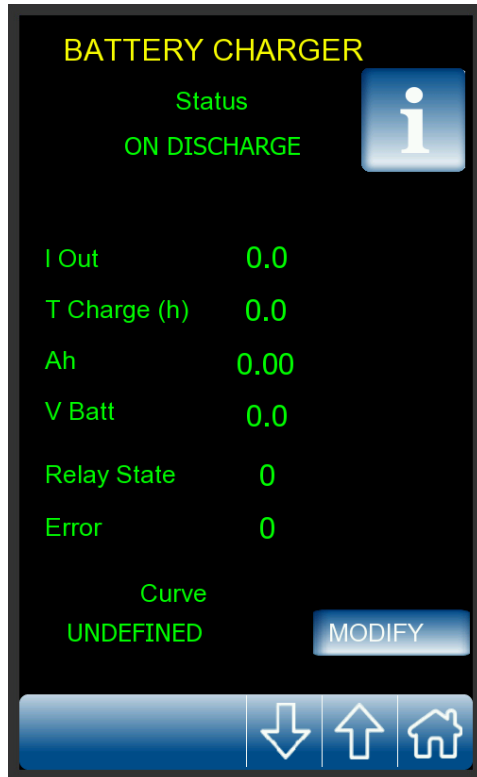

BATTERY AND BATTERY CHARGER SETTING (NORDELETTRONICA Model)

The machine can be equipped with “acido” battery type or “gel” battery type. The battery charger is suitable to charge both type of batteries, but it is necessary set the “curve” of the charge based to the type and brand supplier following the next procedure:

1. Press the icon “settings” to access the SERVICE page (refer to above sketch).
2. Press the icon per accedere alla pagina di impostazioni batteria e carica-batteria.
3. Press the icon to open the selection menu:

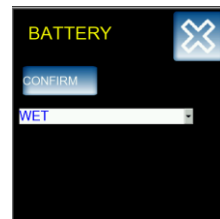

Access the drop down menus to select the type of battery

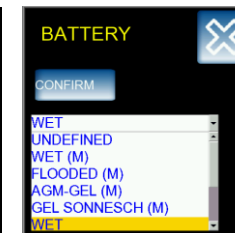

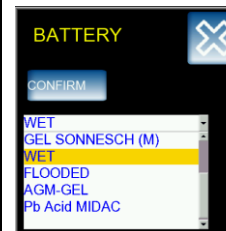

Select from the menu the battery fitted on the machine to determine the charge curve of the battery charger



Select from the menu the type of battery:

- WET: lead acid battery (generic)
- Wet: Enersys Battery
- AGM-GEL: AGM and GEL Battery
- Pb ACID MIDAC: MIDAC Battery

The curves with the (M) are those final WITH MAINTAINING THE END OF CYCLE CHARGE

4. Upon selection made press on the icon  to confirm
5. Close the window pressing the icon 

The selected charging curve is displayed in the parameter "Curve".

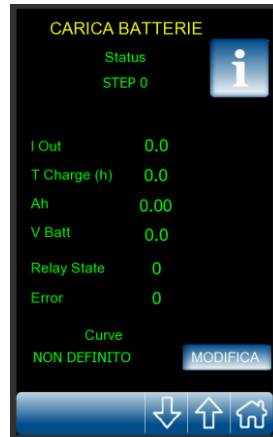

Status = working status

Iout = out-feed battery voltage

Tcharge = charge time

Ah = amper/hour charged

Vbatt = battery voltage

Relay state = relay status into battery charger

Error = error code

Current supplied by battery charger check during charge phase

Connecting the battery charger to the source, during the first minutes the supplied current from battery charger will be 15A \pm 0,5.

Then, checking the parameter Iout = 15A \pm 0,5.to check the appropriate function of the battery charger.

Press the icon  to access the data related to the CB and to counter charges page.

Press the icon  to access the page that highlights the historical data report of the last 100 charges performed.

CB INFO

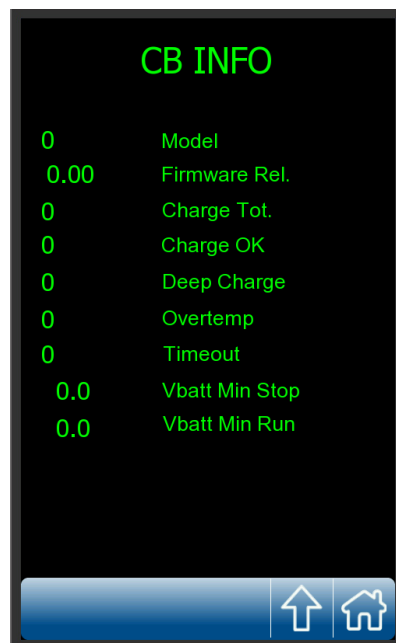

HISTORICAL DATA CHARGING

CHARGING HISTORY

Charge Curve
UNDEFINED

0.00 Ah Loaded Ampere

0 Charging Time (min.)

Date Time
0 / 0 / 0 0 : 0 Time Start Charge
0 / 0 / 0 0 : 0 Time End Discharge Machine last use date/time

0.0 VBatt Min before charge
0 Discharging Time
0.0 VBatt Min Discharge V batt min during use

0

Navigation bar: [Back] [1] [Forward] [Home]

Using the keys  you can select and view the data of the last 100 recharges performed (1 to 100)

ALARM CODES AND/OR WARNINGS

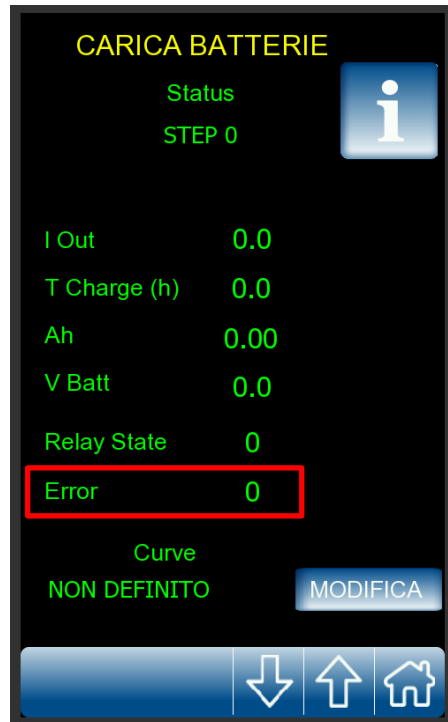



1	EMPTY BATTERY
2	OVERCURRENT ALARM
4	BATTERY DISCONNECTED
8	SHORT CIRCUIT ALARM
16	TIMEOUT ALARM
32	OVERVOLTAGE ALARM
64	CHARGED BATTERY (NO ALARM)
128	TEMPERATURE ALARM

2



TROUBLESHOOTING THROUGH ALARM HISTORY

It is possible to access the alarm history section to check the technical inconvenience had by machine.

1. Press the icona “settings”  to access the SERVICE page (refer to above sketch).
2. Press the icon  to access the page of the alarm history where it is possible to delete the list by pressing the icon  ”

3

INTERNAL MACHINE'S PARAMETER AND LOAD-CELL (EXTENSIONMETER) SETTING

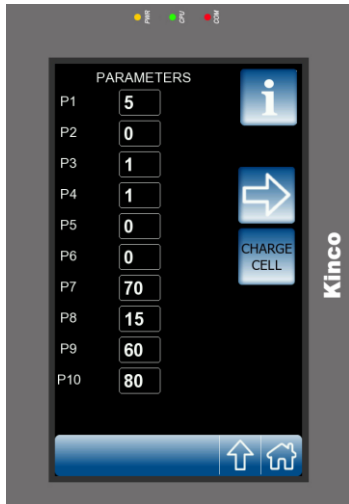

Pressing this icon, it is possible to open the curtain menu of the internal parameter of the machine with explanation of the values set.

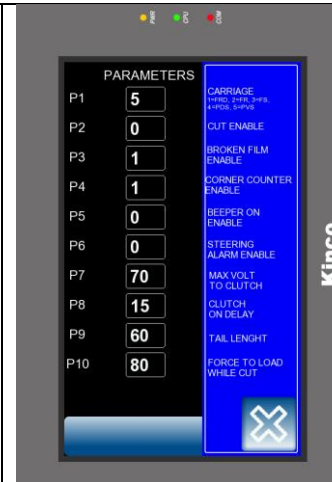

Pressing this icon, it is possible to access to second page of the internal parameter. Pressing the icon it is possible to open the curtain menu with related explanations.

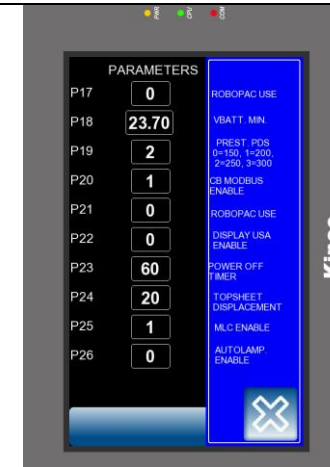
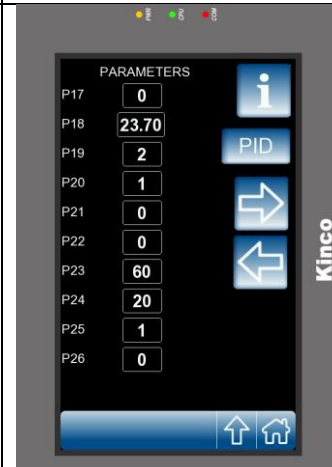

PID

Pressing this icon, it is possible to access the page relating to the PID data (MANAGEMENT PRE-STRETCH).

The values can be changed only with

operator level .

Before change the PID values we recommend you to call ROBOPAC's after sales service

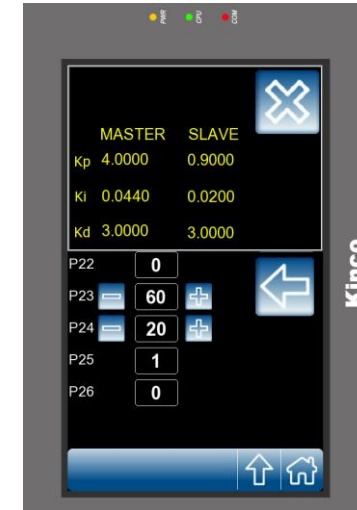
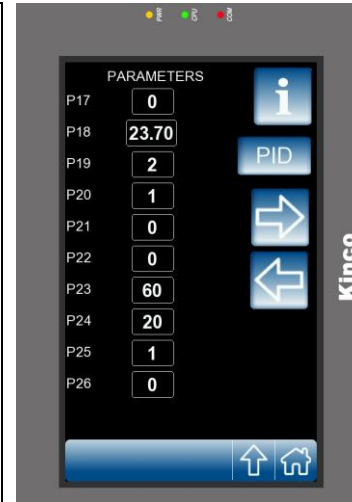

Param	Value	Default	Carriage type					Internal parameter setting description
			FRD	FR	FS	PDS	PVS	
P1	1 – 5	1	1	2	3	4	5	Film carriage type selection
P2	0 – 1	0						Enable cut film device (Optional)
P3	0 – 3	1	0	0	0	1	1	Enable break/cut film alarm 0=disabled 1=enabled with CELL 2=enabled with ENCODER (r-connect) 3=enabled with CELL + ENCODER
P4	0 – 1	1	1	1	1	1	1	Enable of counter-corner alarm (E61)
P5	0 - 1	0	0	0	0	0	0	Enable for acustic signal during whole packing cycle - 1 ONLY for USA -
P6	0 – 1	1	1	1	1	1	1	Enable of steering alarm
P7	0 – 100	70		X	X	X	X	Maximum voltage (V max.) friction for carriages FR/FS/PDS (film stretch / pre-stretch)
P8	0 – 50	15			X	X	X	Delay for brake pre-stretch connection upon machine's start (sec.)
P9	0 – 100	60						Tail length film upon cutting
P10	0 – 100	80						Film stretch during cutting
P17	0 – 1	0						Continuous Start enable (only for Robopac test)
P18	23,3 - 23,8	23,7	(*)	(*)	(*)	(*)	(*)	Minimum battery threshold setting
P19	0 – 3	2						Maximum pre-stretch for PDS - (0=150 / 1=200 / 2=250 / 3=300)
P20	0 – 1	1						Enable modbus connection battery for battery charger
P21	0 – 1	0						FOR ROBOPAC USE ONLY
P22	0 – 1	0						Enable display for North Armerica measures (USA) - 1 ONLY for USA -
P23	30 – 720	60						Power-save time setting (machine shutdown)
P24	0 – 100	20						Down-ward distance spool carriage for top sheet cycle
P25	0 – 1	1						Recipes management Enabling Multilevel Program (MLC)
P26	0 – 1	0						Enabling auto headlight flashing
P27	0 – 1	0						Enabling Roping Device
P28	0 – 500	210						Maximum Roping Device race
P29	0 – 20	2	2	2	2	2	2	Photocell Filter (sec/10)
P30	0 – 20	10						Advance stop mechanical roping
P31	0 – 20	0					0	Pre-stretch compensation (% added to the displayed value)
P35	10-100	55						Film weight (grams / 5 meters)

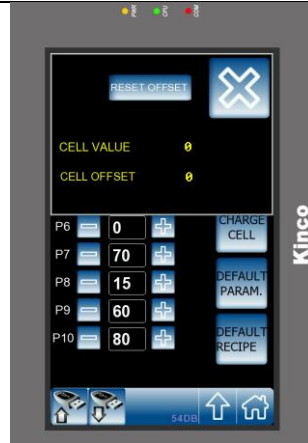

(*) = set this value to 23,5 for battery Pb acid type, and set it to 23,7 for gel battery type

CHARGE
CELL



Pressing the icon  it is possible to access to the window which shows the setting of the load-cell (extensionmeter) to check the appropriate working and setting (display).



With operator selection  Keep pressed the icon  till the displayed value will keep a stable value, it is possible to make the “tuning” of the zero of the load-cell (extensionmeter). The appropriate setting must display a value of 330 ± 30 .

DEFAULT
PARAM.



With operator selection  pressing this icon, it will be possible to set the machine's internal parameters to default values (producer setting).

DEFAULT
RECIPE



With operator selection  pressing this icon, it will be possible to set the machine's packing cycles parameter (recipe) to default values (producer setting)..

4

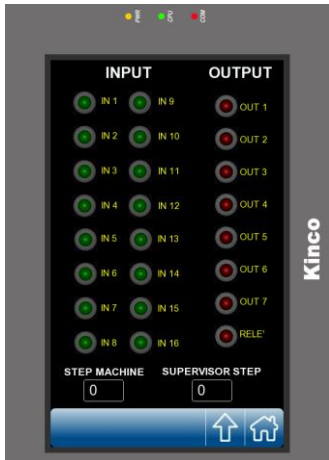

TROUBLESHOOTING THROUGH INPUTS WORKING DISPLAY

This page allow to check if the instruments (sensors and mechanical switches equipped on the machine) are properly working checking the inputs.

I / O compararion table

Inputs		Outputs	
IN1	DL8	OUT1	DL25
IN2	DL9	OUT1	DL26
IN3	DL10	OUT3	DL27
IN4	DL11	OUT4	DL28
IN5	DL12	OUT5	DL29
IN6	DL13	OUT6	DL30
IN8	DL15	OUT7	DL31
IN9	DL16	RELE	K1
IN10	DL17		
IN11	DL18		
IN12	DL19		
IN13	DL20		
IN16	DL23		

LAYOUT MOTHER-BOARD AND I/O DESCRIPTION

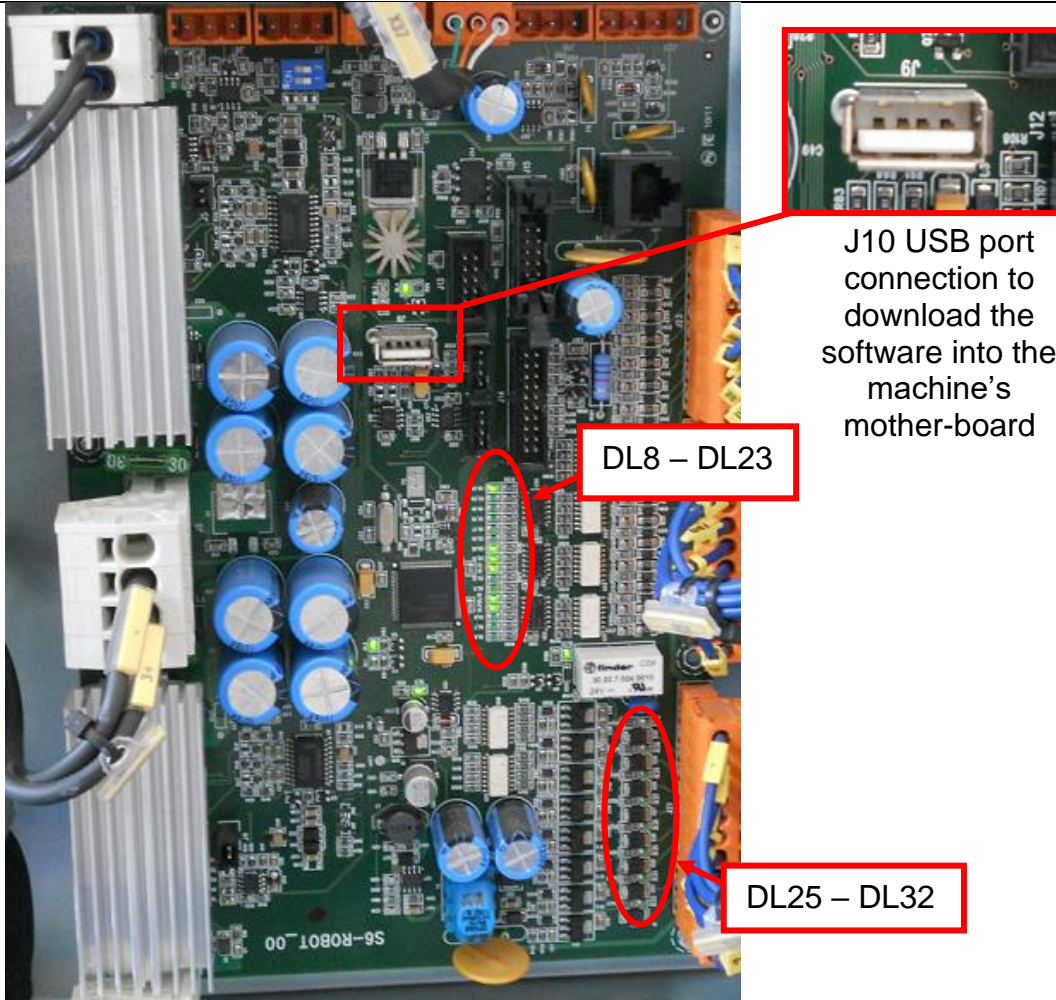

J10 USB port connection to download the software into the machine's mother-board

DL8 – DL23

DL25 – DL32

Led	Input / output description	Contact status	LED status on start
Inputs			
DL8	Emergency	N.O.	OFF
DL9	Start	N.O.	OFF
DL10	Reset	N.O.	OFF
DL11	Top limit switch	N.C.	ON
DL12	Bottom limit switch	N.C.	ON
DL13	Photocell detection product	N.O.	ON
DL14	--		
DL15	Counter corners sensor	N.O.	OFF
DL16	Emergency chain	N.O.	ON
DL17	Bumper emergency	N.C.	ON
DL18	Manual forward	N.O.	OFF
DL19	Manual backward	N.O.	OFF
DL20	Film break (carriages FRD-FR-FS) or Film unwind push button(PVS carriage)	N.O.	OFF
DL21	--		
DL22	--		
DL23	UP/DOWN carriage motor sensor (encoder)	N.O.	OFF
Outputs			
DL25	Power save function		
DL26	Traction brake		
DL27	Film cut		
DL28	Beeper		
DL29	Blinker		
DL32	Brake / Clutch		

TROUBLE-SHOOTING AND HIDDEN FUNCTIONS

In this section are available all notions related to machine's maintenance and trouble-shooting on which can be get access distributor and Robopac's service engineers .

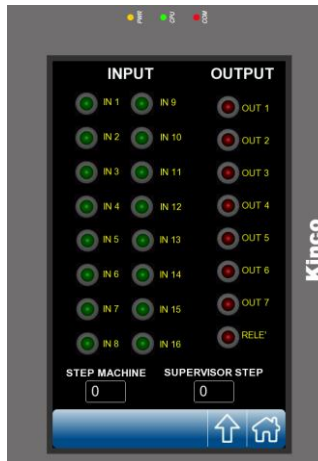
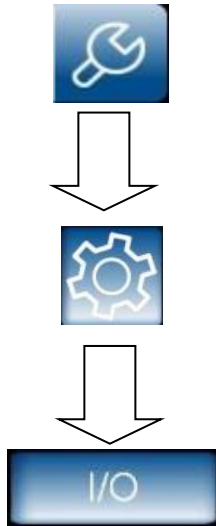

TROUBLESHOOTING THROUGH OUTPUTS CHECKS

The machine is equipped of a particular function that allow you to manually activate some outputs to simulate their appropriate working or the appropriate working of the instruments installed on the machine (sensors, mechanical switches, etc).

Each output can be activated pressing the related red button .

I / O compararion table			
inputs		Outputs	
IN1	DL8	OUT1	DL25
IN2	DL9	OUT1	DL26
IN3	DL10	OUT3	DL27
IN4	DL11	OUT4	DL28
IN5	DL12	OUT5	DL29
IN6	DL13	OUT6	DL30
IN8	DL15	OUT7	DL31
IN9	DL16	RELE	K1
IN10	DL17		
IN11	DL18		
IN12	DL19		
IN13	DL20		
IN16	DL23		

5

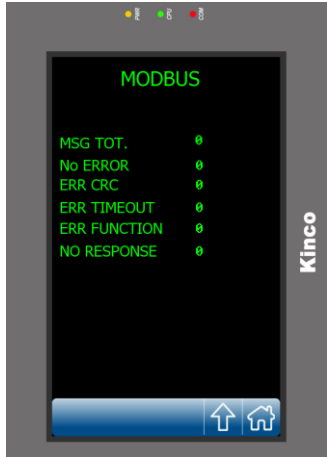

DISPLAYING DATA COMMUNICATION MODBUS

On this page, you can, by pressing the icon  view the communication data transferred from the PLC board of the machine and the touch panel (transfer packages)::

MSG TOT.	Total transmitted messages
No ERROR	Successfully transmitted messages
ERR. CRC	Csum Error
ERR. TIMEOUT	Timeout Error
ERR. FUNCTION	Function Error (describing the type of error)
NO RESPONSE	Error caused by the amplifier card / loan inverter (slave)

6

GRAPHICAL DISPLAY OF STRETCH AND PRE-STRETCH VALUES

Using this page, it is possible to visualize in a graphical way, the minimum, maximum and medium values of film stretch and pre-stretch during the packing cycle.



STRETCH



PRE-STRETCH

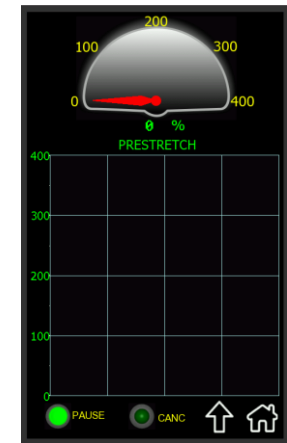

When the related led to “PAUSA / PAUSE” is ON and green, the software of the machine doesn’t display the values of film stretch and pre-stretch. Pressing on the green led, the software start to display the values of film stretch and pre-stretch

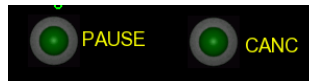

Pressing on the red led “CANC / ERASE” it is possible to erase a previous display of the values to start a new display of film stretch and pre-stretch

7

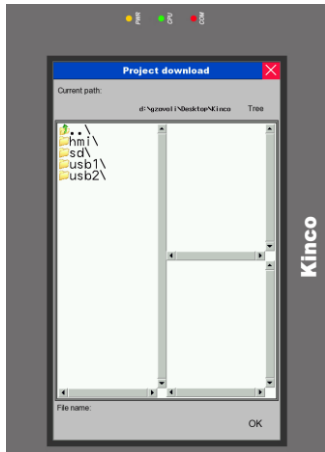

PROCEDURE FOR DOWNLOADING SOFTWARE FOR UPGRADING OF THE CONTROL PANEL "TOUCH SCREEN."

This page allows you to transfer the files from USB key (**usb1 **) inserted into the socket



the touch screen for the control panel software update (**ROBOT_S6.pkg**).

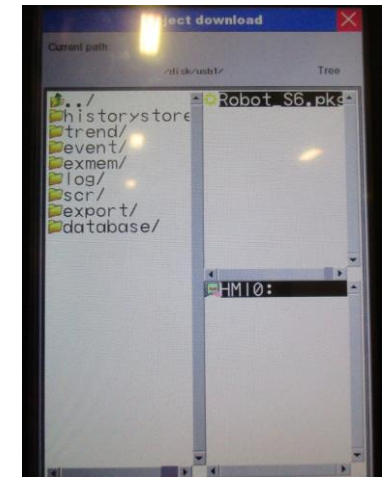
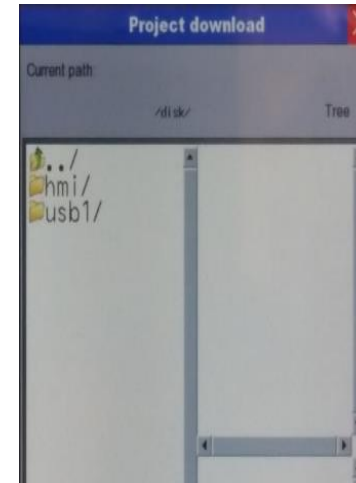



HIDEN FUNCTIONS.

In this section are available all notions related to machine's hidden functions which can be get access distributor and Robopac's service engineers

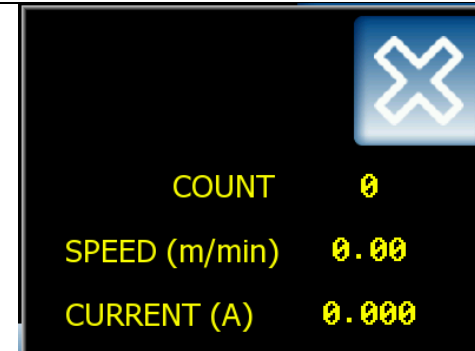

In this page it is possible to activate a packing cycle, and pressing the icon  it will be possible to view the values related to the up/down carriage motor with loads applied



Pressing on the icon "Robopac brand " it is possible to access to the internal section which allow to run the machine and check the consumption and several loadings in the same time.

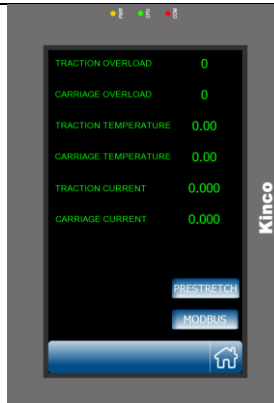

In this page is possible to run a packing cycle and it will be possible to view the loads applied to check any trouble on the machine:

- **Traction motor overload**
- **Up/down spool carriage motor overload**
- **Traction motor temperature**
- **Up/down spool carriage motor temperature**
- **Traction motor current**
- **Up/down spool carriage motor current**



This page allows to set the value of the packing cycle to evaluate the working conditions of the machine with applied loads.

Press this icon  to STOP the packing cycle test.

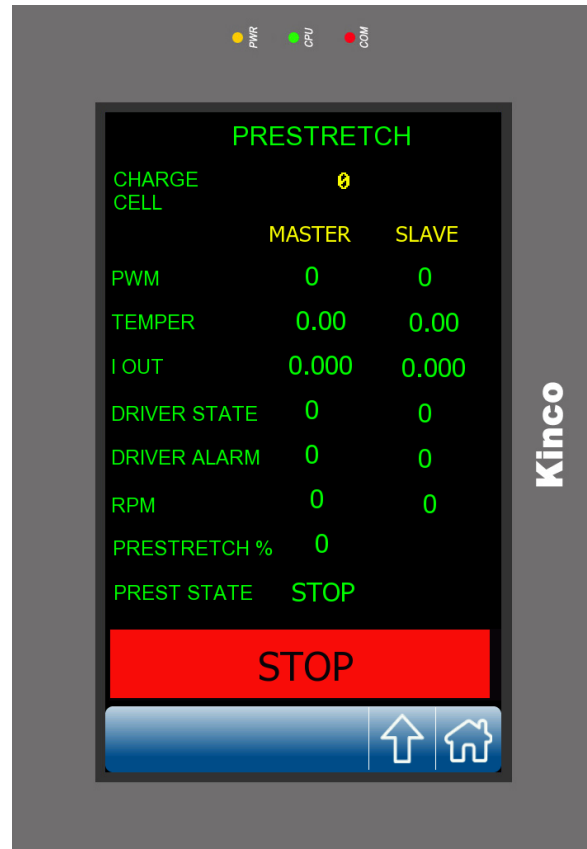



Pressing on the icon **PRESTRETCH** it is possible to access to the page related to the checking of the the values of the pre-stretch (load-cell and amplifier card) and motor pre-stretch (inverter).

CHARGE CELL	Load-cell (extensometer) value
PVM	Inverter running value (fast roll motor & slow roll motor for PVS carriage)
TEMPER	Rotation pre-stretch roll motor temperature (fast roll motor & slow roll motor for PVS carriage)
I_OUT	Current output amplifier/inverter card (fast roll motor & slow roll motor for PVS carriage)
DRIVE STATE	Drive Status (fast roll motor & slow roll motor for PVS carriage)
DRIVE ALARM	Drive alarm (fast roll motor & slow roll motor for PVS carriage)
RPM	Rubber rolls speed (fast & slow roll)
PRESTRECH (%)	Real pre-stretch value (speed ratio between fast and slow roll).
PREST STATE	Pre-stretch status (STOP / RUN)

Press this icon to STOP the packing cycle test.

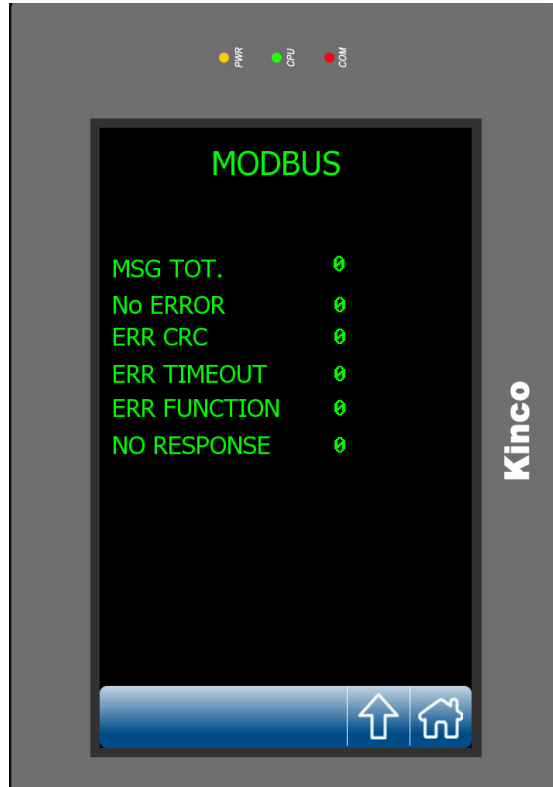
**- ROBOPAC USE ONLY -
INFORMATION RELATED TO SOFTWARE PACK**



In this page, it is possible to run a test packing cycle, and pressing on the icon  it will be possible to view the communication data between PLC and touch-panel of the machine (software pack communicationi):

MSG TOT.	Total transmitted messages
No ERROR	Successfully transmitted messages
ERR. CRC	Csum Error
ERR. TIMEOUT	Timeout Error
ERR. FUNCTION	Function Error (describing the type of error)
NO RESPONSE	Error caused by the amplifier card / loan inverter (slave)

Press this icon  to STOP the packing cycle test.

BATTERY CHARGER SPECIFICATIONS (S.P.E)

The battery charger equipped on the machine, got a diagnostic system through leds indications, to advise working status and fault alarm conditions.

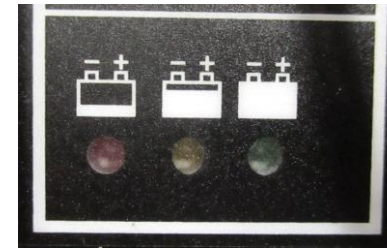
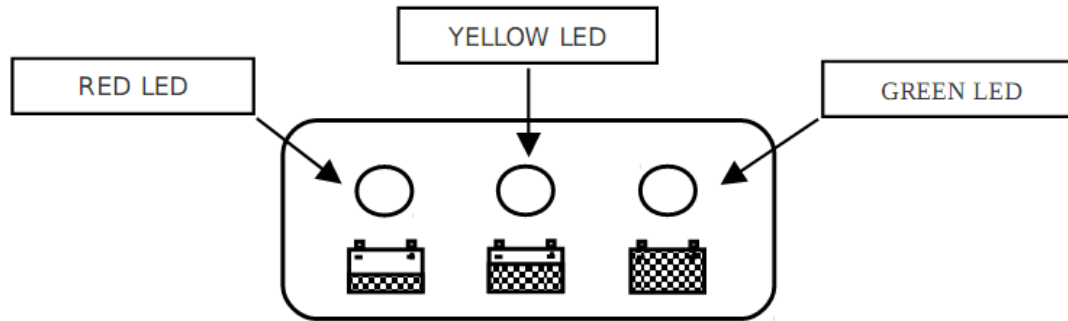

SIGNAL

MEANING

Red Led ON	Normal first charge phase
Yellow Led ON	Normal second charge phase
Green Led ON	End of the charge or maintaining phase
ABNORMAL	
Yellow Led BLINKING	Wrong battery, or not connected or out-feed shortcut
Red Led BLINKING	Overtime safety timer or internal shortcut
STARTING TEST	
Green Led DOUBLE BLINKING	Battery charger set to charge gel battery or AGM battery
Red Led DOUBLE BLINKING	Battery charger set to charge gel battery or Pb-acid battery

Error code	SPE code	Description
0	---	No error
1	E01	Max voltage
2	E02	Thermal Cut Off
3	E03	Time Phase Overflow
4	E03_1	Phase 1 Overflow
5	E03_2	Sulphation (Phase 2 Overflow)
6	EDV	Dv/dt Error
7	EDI	Di/dt Error
8	Srt	Internal Short Circuit
9	Sct	Security timer
10	Openmos	Broken Mofset (Opening)
11	OPC	Connect Battery (Open circuit)
12	Power module fault	Module Error (ex. Broken Module 1)
----	-----	----
240	0xF0	Polarity inversion / no Battery
241	0xF1	Stop Charging
255	0xFF	Error (Generic)



 Norm. Tecn. 60.2.49_14	TECHNICAL DOCUMENTATION - ROBOT S6 (Touch Screen Kinco Version) -	Date: October 2021	Rev.16
	ENGLISH	Pag. 88 / 113	

BATTERY CHARGER SPECIFICATIONS (NORD ELETTRONICA)

OPERATION:

The battery charger uses a combination of charge at constant current and constant voltage. This makes possible a significant reduction of the charging time and prevents permanent damage to the battery.

TECHNICAL CHARACTERISTICS:

- Input: 100-240Vac 5A - 2A 50/60Hz
- Output: 24Vdc - 15A
- Battery: 100 ÷ 160Ah (C5) / 120 ÷ 180Ah (C20))

PROTECTIONS:

- Input fuse : 10A 250V delayed (internal fuse)
- Reverse polarity
- Short circuit
- Overcurrent
- Overvoltage
- Overtemperature

Use the dip switches to choose the charging algorithm according to the type of battery. At switch on, the green led flashes to indicate which algorithm is selected via dip switches (see table **Selecting the charging curve**).

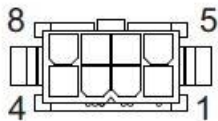
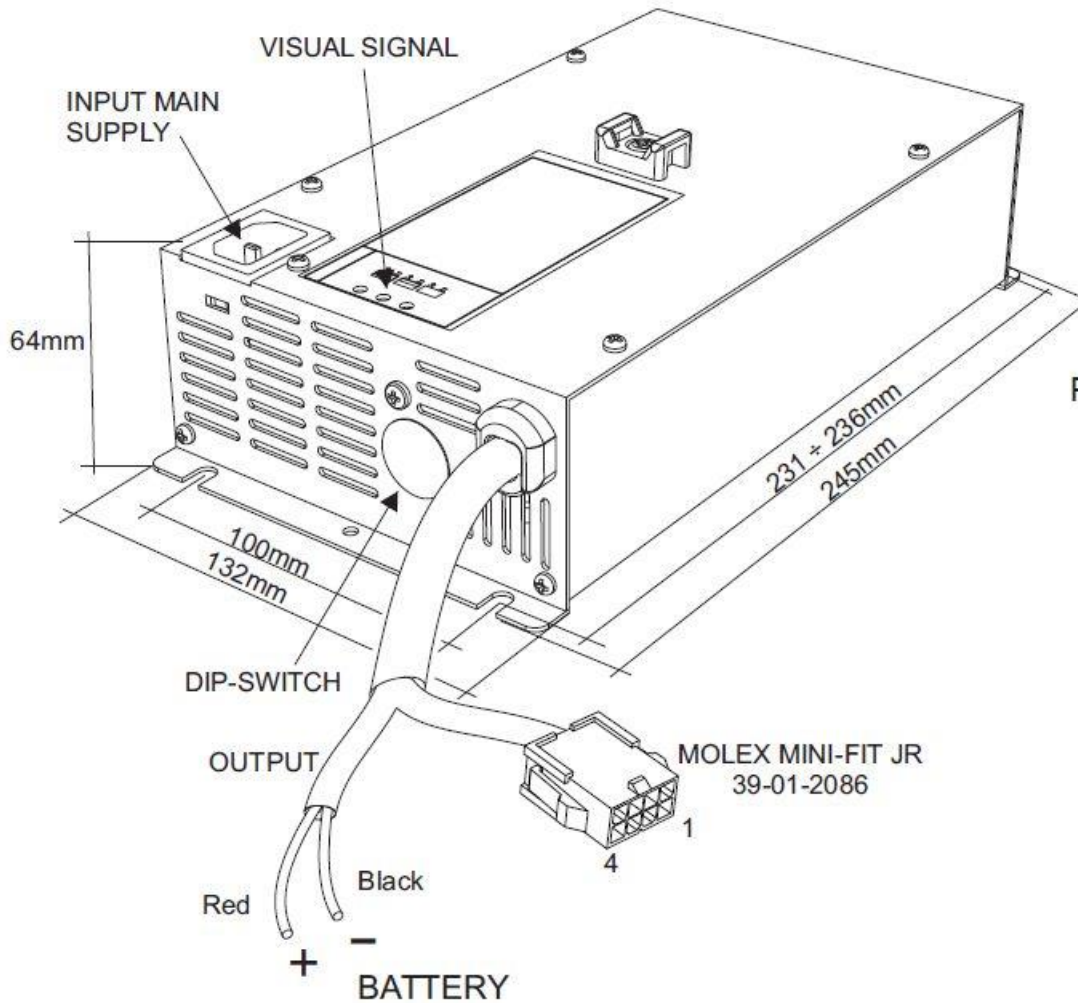





1	no connect
2	no connect
3	COM Relay contact
4	NC Relay contact
5	NO Relay contact
6	RS485-A
7	RS485-B
8	no connect

ROBOPAC Norm. Tecn. 60.2.49_14	TECHNICAL DOCUMENTATION - ROBOT S6 (Touch Screen Kinco Version) -	Date: October 2021	Rev.16
	ENGLISH	Pag. 90 / 113	

The battery charger equipped on the machine, got a diagnostic system through leds indications, to advise working status and fault alarm conditions.

VISUAL SIGNALS:

- | | | |
|-----------------|---|--------------------------------------|
| - Flashing Red: |  | Verification phase of battery status |
| - Red: |  | First phase of charge |
| - Yellow: |  | Second phase of charge |
| - Green: |  | Battery charged - Maintenance phase |

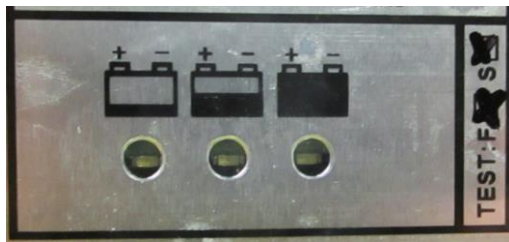

REPORTING	SIGNIFICATO
Red Led Flashing	Verification phase of battery status
Red Led Fixed	First phase of charge
Jellow Led Fixed	Second phase of charge
Green Led Fixed	Battery charged - Maintenance phase
ALARMS	
1 flashing yellow LED	Battery disconnected or reverse polarity or output short circuit (1)
1 flashing yellow LED	Alarm time-out: damaged battery or battery capacity is too high (2)
1 flashing yellow LED	Faulty battery charger (2)
1 flashing yellow LED	Overtemperature (3)
FIRST TEST	
See table.	

- (1) Verify the battery connection.
- (2) The alarm is reset disconnecting the main supply. If it persists consult your service.
- (3) The alarm will be reset itself when the charger cools. Verify the ventilation.

Selecting the charging curve

It's possible to select any of 8 curves stored in the CB either through Dip-switch S1, S2, S4 via Modbus

As soon as the Battery Charger is connected to the supply, the flashes of yellow and green LEDs show the curve currently selected (see table).

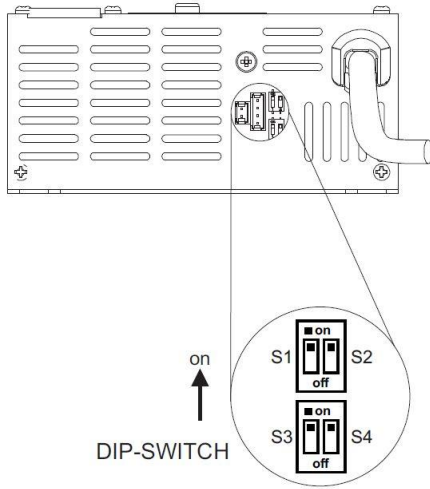

S1	S2	S4	Reference Dip-switch	Algorithm	Status of yellow LED at switch on	Number of flashes of the green LED at switch on
OFF	OFF	OFF	1	IUI0-Pb Flooded	OFF	1
ON	ON	OFF	2	IUI0-Pb Flooded-EnerSys	OFF	2
OFF	ON	OFF	3	IUoU-AGM-GEL	OFF	3
ON	OFF	OFF	4	IUI0-Pb Flooded-Midac	OFF	4
OFF	OFF	ON	5	IUIa-Pb Flooded	ON	1
ON	ON	ON	6	IUIa-Pb Flooded-EnerSys	ON	2
OFF	ON	ON	7	IUa-AGM-GEL	ON	3
ON	OFF	ON	8	IUIa-Pb Flooded-Midac	ON	4

S3	Output current
ON	13A
OFF	15A

PLEASE NOTE:

If through the Modbus a different algorithm was selected, the charger will always apply as long as the latter will not be selected (always via Modbus) another algorithm.

If the operator manually change one of dip-switch S1, S2 or S4 will clear any previously made selection through Modbus and will apply the algorithm to the table.

The dip switches are moved in the absence of the network (charger off).

It can happen so that the curve followed by the charger does not correspond to the one selected by dip-switch (even though initial flashes indicate the correct curve).

To restore the correspondence simply move any one of dip-switch.

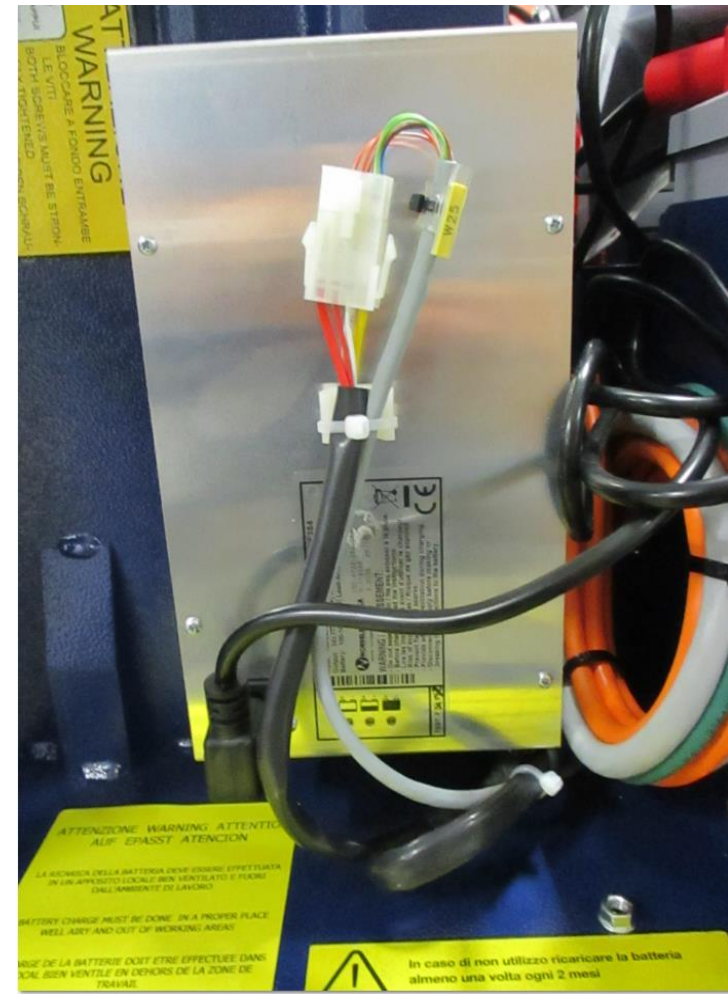

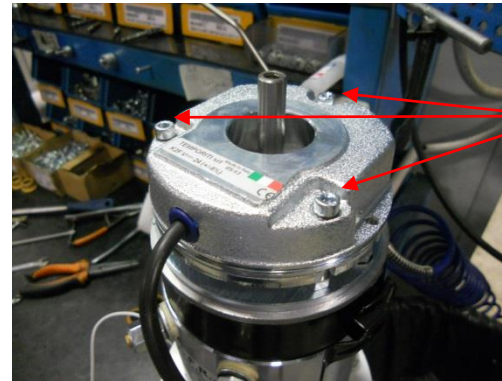
TRACTION MOTOR BRAKE SETTING NOTIONS

Unlock these three screws a little bit to be able to move the three adjusting screws (in the bottom).
After adjusting relock these three screws.

This is the distance, that must be overdone by the electromagnetic



Using a spacer made of 0,2 – 0,3 mm thickness, adjust the three bottom screws being sure to uniformly adjust them in the appropriate way to have a constant gap all around the diameter of the magnetic brake.

ROBOPAC Norm. Tecn. 60.2.49_14	TECHNICAL DOCUMENTATION - ROBOT S6 (Touch Screen Kinco Version) -	Date: October 2021	Rev.16
	ENGLISH	Pag. 94 / 113	

PRODUCT HEIGHT DETECTION PHOTOCELL CALIBRATION

Standard photocell (for clear products)

Approach the robot to the pallet and position the carriage to align the photocell to the product.

Adjust the photocell sensitivity trimmer in order to activate the input



Move the carriage over the pallet in order to clear the photocell and check if the input switch off

Dark product photocell (Datalogic model)

Suppression distance setting

1. Object detection

Position object to detect in front of the sensor at the distance required.
Turn distance adjustment trimmer (ADJ) to minimum: yellow LED OFF and green LED ON.



Rotate trimmer in a clockwise direction until the yellow LED and green LED turn ON. Object detection condition (A status of position indicator)



A

2. Background suppression

Remove object and ensure that the background is in front of the sensor: yellow LED OFF and green LED ON.



Rotate trimmer in a clockwise direction until the yellow LED and green LED turn ON: background detection condition (B status of position indicator).



B

The trimmer reaches maximum level with yellow LED OFF if the background is outside the operating range.

Rotate trimmer in an anticlockwise direction until yellow LED turns OFF and green LED ON: condition where background is outside operating range (C status of position indicator).



C

3. Setting and control

Rotate trimmer in an anticlockwise direction until the indicator reaches an intermediate point between position A and C.



If position A and C are close to each other, leave trimmer on position C. The sensor is now ready to function correctly and in stable conditions:



DETECTION DIAGRAM

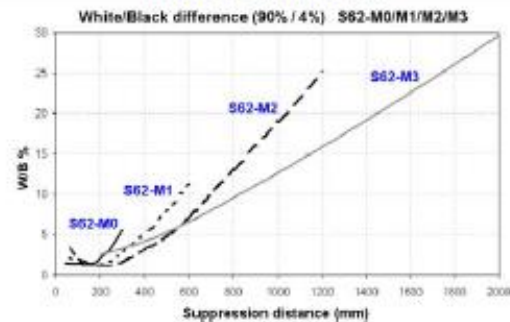

Dark product photocell (Sunx model)

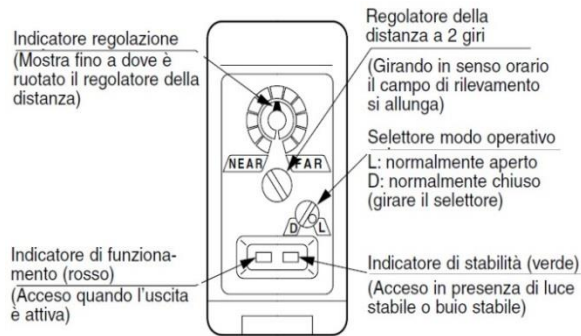

Set the selector "operation mode" to "L"
(turn the selector clock-wise direction till the end).

Sensitivity setting for dark product photocell

Turn completely the selector counter clock-wise direction in case of minimum distance (about 0.2mm).

Locate the object to detect from the photocell (pallet centre) and turn the selector clock-wise direction till "A" to set the photocell in "light" condition (output active)

Remove the a.m. object. Turn the selector in clock-wise direction till switch again the photocell to "light" condition. When it become on, turn again the selector to switch to "dark" to "B" (if absence of the object to detect the photocell do not switch to "light" condition ON, the "B" point must be considered like maximum point of the setting range).

Set the selector to half range (middle between point "A" and point "B" that should be the best point to detect the object).

Distance selector

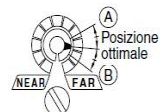
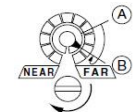
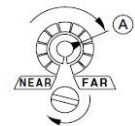
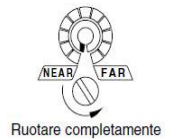

Photocell for black products S65

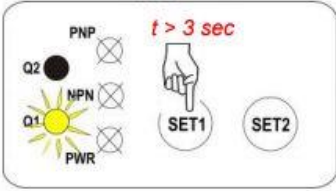
	<p>Place the target at the center of the pallet</p>
<p>Teach-In</p> 	<p>Keep pressed the Set1 button for more than 3 seconds, till led Q1 flashing</p>
	<p>Release the button, target detected</p>

 Norm. Tecn. 60.2.49_14	TECHNICAL DOCUMENTATION - ROBOT S6 (Touch Screen Kinco Version) -	Date: October 2021	Rev.16
	ENGLISH	Pag. 98 / 113	

POWER VOLTAGE TEST FOR SPOOL CARRIAGE CLUTCH / BRAKE

FS-PDS Carriage	Setting the film pre-stretch setting icon to maximum value, turn ON the machine and measure the voltage to the connections on the brake of the spool carriage. The measured value must be 15 Volt $\pm 0,5$ Volt.
FR Carriage:	Setting the film stretch setting icon to maximum value, turn ON the machine and measure the voltage to the connections on the brake of the spool carriage. The measured value must be 7 Volt $\pm 0,5$ Volt.

ROPING DEVICE CALIBRATION

If setting a percentage value of the roping device (for example 25% or 65% ...) the device does not reach the correct position but "oscillates" around the set height --- > roping device calibration is required

- check the value of the parameter P28 (max roping stroke)
- set the roping device to 50%
- start the cycle
- stop the cycle when the roping reaches the set height



- enter with the Service PSW 6161
- select the manual roping device page and press ROPING SETUP
- check the COUNT value (it has to be COUNT = P28/2)
- if COUNT < P28/2 decrement P30 of P28/2 – COUNT
- se COUNT > P28/2 increase P30 of COUNT - P28/2

 Norm. Tecn. 60.2.49_14	TECHNICAL DOCUMENTATION - ROBOT S6 (Touch Screen Kinco Version) -	Date: October 2021	Rev.16
	ENGLISH	Pag. 99 / 113	

R-CONNECT DEVICE ACTIVATION

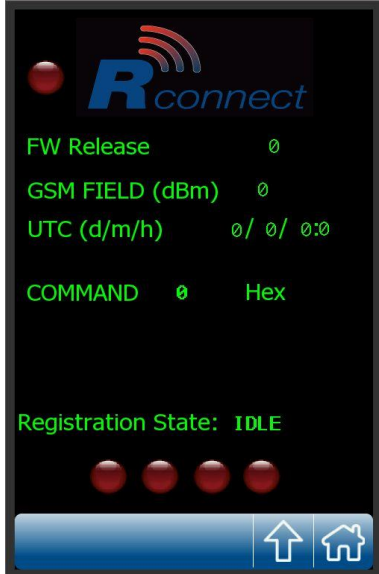

<p>R-Connect devices registration</p> <p>check that the FW Release and GSM field fields have values other than 0 Check that the LED at the top next to the Rconnect logo is GREEN (Modbus OK) Press the 'REGISTER' button and wait until all 4 LEDs are green</p>	
--	--

ALARM LIST AND TROUBLE-SHOOTING

Alarm Code	Alarm description	Troubleshooting	Cause of the fault	Solution
	Emergency push button pressed			Rotate and pull the emergency push button, then, press RESET
		Check the electric contact of the emergency push button SB1	The electric contact is defective	Replace the electric contact of the emergency push button SB1
		Check that input #2 (DL8) on mother-board works fine.	Input damaged on mother-board	Replace mother-board.



E 10	Bumper alarm				Press RESET button to run the machine.
			Check the electric contact on the mechanical switches SQ10 & SQ11 of the bumper	The electric contacts of the mechanical switches are defective	Replace the mechanical switches.
			Check that input #2 (DL17) on plc-card works fine.	Input damaged on mother-board	Replace mother-board.
TRACTION DRIVER ALARM (E30) DRIVER ###.##	Traction drive motor alarm - TRACTION DRIVER OVERTEMP - TRACTION DRIVER SHORT CIRCUIT - TRACTION DRIVER UNDERVOLT - TRACTION HEAT SINK OVERTEMP - TRACTION CURRENT LIMIT		Disconnect motor from mother-board and run a cycle	The arlam message disappear. The alarm message persists	Replace traction motor. Replace mother-board
			Check the conditions of the brake connected to the traction motor	Defect on the brake.	Replace brake
			Check the gearbox connected to the traction motor	Defect on the gearbox.	Replace gearbox

	Up / down spool carriage drive motor alarm	- UP/DOWN CARRIAGE MOTOR DRIVER OVERTEMP - UP/DOWN CARRIAGE MOTOR DRIVER SHORT CIRCUIT - UP/DOWN CARRIAGE MOTOR DRIVER UNDERVOLT - UP/DOWN CARRIAGE MOTOR HEAT SINK OVERTEMP - UP/DOWN CARRIAGE MOTOR CURRENT LIMIT	Disconnect motor from mother-board and run a cycle	If the error message no longer appears, it is a possible carriage motor failure. If this message persists, it is a possible mother-board failure	Replace up/down carriage motor. Replace mother-board
		Check the gearbox connected to the traction motor	Defect on the gearbox.	Replace gearbox	

	Film stretch motor alarm	<ul style="list-style-type: none"> - FILM STRETCH MOTOR DRIVER OVERTEMP - FILM STRETCH MOTOR DRIVER SHORT CIRCUIT - FILM STRETCH MOTOR DRIVER UNDERVOLT - FILM STRETCH MOTOR HEAT SINK OVERTEMP - FILM STRETCH MOTOR CURRENT LIMIT 	Disconnect film stretch motor from inverter drive card and run a cycle.	If the error message no longer appears, it is a possible film stretch motor failure.	Replace film stretch motor.
		If this message persists, it is a possible failure of the film stretch motor inverter card.		Replace film stretch inverter card	
	Pre-stretch motor alarm	<ul style="list-style-type: none"> - PRE-STRETCH MOTOR DRIVER OVERTEMP - PRE-STRETCH MOTOR DRIVER SHORT CIRCUIT - PRE-STRETCH MOTOR DRIVER UNDERVOLT - PRE-STRETCH MOTOR HEAT SINK OVERTEMP - PRE-STRETCH MOTOR CURRENT LIMIT 	Disconnect pre-streth motor from inverter drive card and run a cycle.	If the error message no longer appears, it is a possible pre-stretch motot failure.	Replace pre-stretch motor.
		If this message persists, it is a possible failure of the pre-stretch motor inverter card.		Replace pre-stretch inverter card	

<p style="text-align: center;"> TRACTION MOTOR OVERCURRENT (E 35) </p>	<p>Traction drive motor overcurrent alarm</p>	<p>Disconnect motor from mother-board and run a cycle</p>	<p>If the error message no longer appears, it is a possible fault in the traction motor.</p>	<p>Replace traction motor.</p>
			<p>If this message persists, it is a possible mother-board failure</p>	<p>Replace mother-board</p>
		<p>Check the conditions of the brake connected to the traction motor</p>	<p>Defect on the brake.</p>	<p>Replace the motor brake traction</p>
		<p>Check the gearbox connected to the traction motor</p>	<p>Defect on the gearbox.</p>	<p>Replace gearbox</p>
<p style="text-align: center;"> ALLARME SOVRACORRENTE MOTORE CARRELLO (E36) </p>	<p>Up / down spool carriage drive motor overcurrent alarm</p>	<p>Disconnect up/down carriage motor from mother-board and run a cycle</p>	<p>If the error message no longer appears, it is a possible fault in the up/down carriage motor.</p>	<p>Replace up/down carriage motor.</p>
			<p>If this message persists, it is a possible mother-board failure</p>	<p>Replace mother-board</p>
		<p>Check the gearbox connected to the carriage motor</p>	<p>Defect on the gearbox.</p>	<p>Replace gearbox</p>



BROKEN FILM ALARM (E60)	Film broken/finished alarm (option)			Replace the film reel on the carriage or connect the film to the product and press STAR.
		On models equipped with FRD, FR and FS carriages, check the position of the inductive sensor compared to the related cam on the free roll.	Wrong sensors position	Adjust the inductive sensor in the appropriate position.
		Check that inductive sensor works properly	Defect to the inductive sensor or its wiring.	Replaced inductive sensor
		Check input #5 (DL20) on mother-board	Damage of mother-board	Replaced mother-board
		On models equipped of PDS & PVS carriages, check that load-cell is working properly	Load-cell does not manage to send the appropriate signal to the amplifier card	Replace load-cell
			Load-cell works properly	Replace amplifier card
		If present the film consumption sensor (r-connect) and the parameter P3 = 2 or P3 = 3	The film consumption sensor is not working properly	Check the mechanical position of the sensor
				Check the electrical connections of the sensor
Replace the film consumption sensor				

<p style="text-align: center;">COUNTER CORNER ALARM (E61)</p>	<p>Counter-corner sensor alarm</p> 	<p>Check that inductive sensor is properly positioned compared its cam</p>	<p>Wrong sensors position</p>	<p>Adjust the inductive sensor in the appropriate position.</p>
		<p>Check that inductive sensor works properly</p>	<p>Defect to the inductive sensor or its wiring.</p>	<p>Replaced inductive sensor</p>
		<p>Check input #9 (DL15) on mother-board</p>	<p>Damage of mother-board</p>	<p>Replaced mother-board</p>
<p style="text-align: center;">ENCODER CARRIAGE ALARM (E62)</p>	<p>Up / down carriage motor encoder alarm</p> 	<p>Check that inductive sensor is properly positioned compared its cam</p>	<p>Wrong sensors position</p>	<p>Adjust the inductive sensor in the appropriate position.</p>
		<p>Check that inductive sensor works properly</p>	<p>Defect to the inductive sensor or its wiring.</p>	<p>Replaced inductive sensor</p>
		<p>Check input #8 (DL23) on mother-board.</p>	<p>Damage of mother-board</p>	<p>Replaced mother-board</p>

	Blocked Roping device Alarm	<p>ALRM VOLT</p> <p>Roping device card power supply too,low</p>	Check roping device card power supply	Possible problem in the roping device card power supply chain	Check the power supply from the battery to the roping device card	
		<p>ALRM MOT</p> <p>Overcurrent on the motor output</p>	Check the motor is not forcing	Possible problem in the roping device card	Replace the roping device card	Replace the motor Replace the brake
		<p>ALRM BRAKE</p> <p>Overcurrent on the brake output</p>	Check the motor is not forcing	Possible problem in the roping device card	Replace the roping device card	Replace the motor Replace the brake
		<p>ALRM BLOCK</p> <p>Blocked motor or damaged sensor</p>	Check the motor is not forcing	Possible problem in the roping device card	Replace the roping device card	Replace the motor Replace the brake
			Possible problem in the roping device card	Replace the roping device card	Wiring possible problem	Check sensor-card connections
			The card does not read the inputs from the phonic wheel sensor	Possible problem in the roping device card	Possible sensor wrong position	Replace the roping device card Make mechanical regulation of the sensor to read the phonic wheel petals
					Sensor possible problem	Replace the sensor

	<p>Roping microswitch Alarm, roping card low power supply or correct roping position not reached</p>	<p>Check roping device card power supply</p>	<p>Possible problem in the roping device card power supply chain</p>	<p>Check the power supply from the battery to the roping device card</p>
			<p>Possible problem in the roping device card</p>	<p>Replace the roping device card</p>
		<p>Check up and/or down microswitch</p>	<p>Possible position problem of the microswitch</p>	<p>Adjust the micro</p>
			<p>Possible problem of the microswitch connection</p>	<p>Check connections and/or replace the micro</p>
		<p>The card does not read the inputs from the phonic wheel sensor</p>		<p>Check / replace the roping card</p>
			<p>Wiring possible problem</p>	<p>Check sensor-card connections</p>
			<p>Possible problem in the roping device card</p>	<p>Replace the roping device card</p>
			<p>Possible sensor wrong position</p>	<p>Make mechanical regulation of the sensor to read the phonic wheel petals</p>
		<p>Sensor possible problem</p>	<p>Replace the sensor</p>	
<p>E80</p>	<p>Battery charger alarm</p>		<p>Battery charger device fault</p>	<p>Refer to battery charger device's troubleshooting on above pages (paragraph #14).</p>

<p style="text-align: center;"> MODBUS H.M.I. ALARM (E81) </p>	<p>Communication alarm between touch panel and mother-board</p>	<p>Check cable which connect touch panel to mother-board</p>	<p>Defect of the cable</p>	<p>Replace cable</p>
		<p>Chek touch-panel and mother-board</p>	<p>Fault of connectors of the mother-board or touch panel</p>	<p>Replace mother-board or touch panel</p>
<p style="text-align: center;"> MODBUS PRESTRETCH ALARM (E82) </p>	<p>Communication alarm between mother-board and amplifier/inverter card</p>	<p>Check cable which connect mother-board to amplifier/inverter card</p>	<p>Defect of the cable</p>	<p>Replace cable</p>
		<p>Chek mother-board and amplifier/inverter card</p>	<p>Fault of connectors of the mother-board or amplifier/inverter card</p>	<p>Replace mother-board or amplifier/inverter card</p>

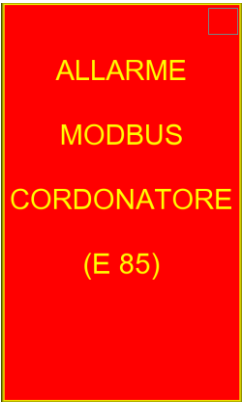
<p>Device</p> 	<p>Wrong configuration of parameters</p> <p>The list of parameters is not 'consistent with the value of Csum stored.</p>	<p>When the machine turn on it was found a discrepancy between the configuration parameters stored in the memory and the set.</p>	<p>Possible is a "damaging the machine configuration parameters.</p>	<p>Restore the correct parameters by copying from the USB stick with the machine</p>  <p>Or, to manually set the parameters, press the button</p> 
	<p>Anomaly of the Roping Device circuit.</p>	<p>Check electrical connections and card of the Roping Device.</p>	<p>The Roping Device control card may be fault.</p>	<p>Replace The Roping Device control card.</p>



Norm. Tecn.
60.2.49_14

TECHNICAL DOCUMENTATION
- ROBOT S6 (Touch Screen Kinco Version) -

Date:
October 2021

Rev.16

ENGLISH

Pag. 111 / 113

E 90

Battery discharged alarm

Battery on board of
machine are discharged

Immediately plug the
battery charger of the
machine to the power
source



Norm. Tecn.
60.2.49_14

TECHNICAL DOCUMENTATION
- ROBOT S6 (Touch Screen Kinco Version) -

Date:
October 2021

Rev.16

ENGLISH

Pag. 112 / 113

The machine doesn't pre-stretch the film properly	Check the run of the film into the rolls of the spool carriage and check the quality of the film.	Possible improper use of the machine.	Apply on the machine the correct film and run it properly into the rolls following the instructions.
	On machines equipped of FS or PDS, check the conditions of the clutch	The clutch is completely wear	Replace clutch
		The clutch receive the appropriate voltage (refer to above paragprh #16)	Replace clutch
	On machines equipped of PVS carriage, check the amplifier/inverter card	The clutch doesn't receive the appropriate voltage (refer to above paragprh #16)	Replace mother-board
Defect of amplifier/inverter card		Replace amplifier/inverter card	

The film breaks during packing or it is not properly applied to the product (too tight or too light).	Check the run of the film into the rolls of the spool carriage and check the quality of the film.	Possible improper use of the machine.	Apply on the machine the correct film and run it properly into the rolls following the instructions.
	Check that load-cell (extensiometer) isn't mechanically damaged or wrongly mounted	Check that load-cell (extensiometer) isn't properly fit or it is mechanically defected	Make sure of the appropriate installation of the load-cell (extensiometer). If the instrument is properly fit, replace it because it could be defected.
	Check that load-cell (extensiometer) isn't electrically defected	Electrical defect of the load-cell (extensiometer) for the film stretch sensitivity	Make the setting of the load-cell (extensiometer) following the instruction on above page 24. In case it will be not possible to get the appropriate setting, replace it because it could be defected.
	Check that the amplifier/inverter card for the signal of the load-cell (extensiomenter) isn't electrically defected	Defect of the amplifier/inverter card	Make the setting of the load-cell (extensiometer) following the instruction on above page 24. In case it will be not possible to get the appropriate setting, replace it because it could be defected.