

# TECHNICAL DOCUMENTATION - ROBOT S6 (WEINTEK)



Date	Revisions	Revisions Reasons	Issue	Checked by	Approved by
28/03/2012	01	First Issue	<i>Saravelli D.</i>	<i>Saravelli D.</i>	<i>Saravelli D.</i>
16/01/2013	02	Software Revision sw rel.6.0	<i>Saravelli D.</i>	<i>Saravelli D.</i>	<i>Saravelli D.</i>
03/11/2016	03	General review - Kinco	<i>Zavoli S.</i>	<i>Zavoli S.</i>	<i>Zavoli S.</i>
26/04/2017	04	Carriages and Stretch Control	<i>Baldinini F.</i>	<i>Baldinini F.</i>	<i>Baldinini F.</i>
12/06/2018	05	Addition E32 alarm (was missing)	<i>Baldinini F.</i>	<i>Baldinini F.</i>	<i>Baldinini F.</i>
23/07/2018	06	Index realization	<i>Baldinini F.</i>	<i>Baldinini F.</i>	<i>Baldinini F.</i>

 <b>Norm. Tecn.</b> <b>60.2.49_05</b>	<b>TECHNICAL DOCUMENTATION</b> <b>- ROBOT S6 (Touch Screen Weintek Version) -</b>	<b>Date:</b> <b>July 2018</b>	<b>Rev.06</b>
	<b>ENGLISH</b>	<b>Pag. 2 / 86</b>	

## Index

MACHINE LAY-OUT.....	6
FILM SPOOL CARRIAGE DETAILED SKETCHES .....	7
OPERATOR PANEL DESCRITPION .....	11
BATTERY STATUS INDICATIONS DISPLAY .....	11
DESCRIPTION AND MAIN ELECTRICAL PANEL LAYOUT .....	12
ELECTRONIC CARDS DESCRIPTION.....	13
PLC + INVERTER Card (Main Board) (U1)– CODE 1430300180 .....	13
Pre-stretch Card 1 Motor (U3) – CODE 1430300198 .....	17
Pre-stretch Card 2 Motors (U3) – CODE 1430300181.....	20

 <b>Norm. Tecn.</b> <b>60.2.49_05</b>	<b>TECHNICAL DOCUMENTATION</b> <b>- ROBOT S6 (Touch Screen Weintek Version) -</b>	<b>Date:</b> <b>July 2018</b>	<b>Rev.06</b>
	<b>ENGLISH</b>	<b>Pag. 3 / 86</b>	

POWER SAVE” FUNCTION (MACHINE STAND-BY) .....	22
“POWER SAVE” FUNCTION (MACHINE SHUTDOWN).....	22
LIST OF RECIPES DATA .....	23
GENERAL FUNCTIONS AVAILABLE ON TOUCH-PANEL .....	27
HOW TO USE THE ACCESS PASSWORD OF THE OPERATOR TOUCH-PANEL .....	28
MACHINE’S END-USER SECTION .....	30
Active functions without password inserted .....	30
Active functions with password inserted .....	30
PACKING PARAMETER SETTING .....	35
Packing cycle parameters description .....	36
BATTERY TEST CONDITION FUNCTION.....	40
MANUAL FORWARD SPEED ADJUSTMENT FUNCTION.....	40
SERVICE SECTION (MACCHINE MAINTENANCE.....	41
TOUCH-SCREEN PANEL SETTING AND DOWNLOAD .....	42
TOUCH-SCREEN PANEL SETTING (Weintek MT6070iH model).....	42
TOUCH-SCREEN PANEL SOFTWARE DOWNLOAD PROCEDURE (Weintek MT6070iH model) .....	44
TOUCH-SCREEN PANEL SETTING (Weintek MT8071iE model).....	46
TOUCH-SCREEN PANNEL SOFTWARE DOWNLOAD PROCEDURE (Weintek MT8071iE model).....	48

 <b>Norm. Tecn.</b> <b>60.2.49_05</b>	<b>TECHNICAL DOCUMENTATION</b> <b>- ROBOT S6 (Touch Screen Weintek Version) -</b>	<b>Date:</b> <b>July 2018</b>	<b>Rev.06</b>
	<b>ENGLISH</b>	<b>Pag. 4 / 86</b>	

MOTHER-BOARD (U1) SOFTWARE DOWNLOAD PROCEDURE .....	51
AMPLIFIER CARD / PRE-STRETCH MOTOR INVERTER (U3) SOFTWARE DOWNLOAD PROCEDURE.....	52
MACHINE SETTINGS AND FUNCTIONS .....	54
BATTERY AND BATTERY CHARGER SETTING .....	55
TROUBLESHOOTING THROUGH ALARM HISTORY .....	57
INTERNAL MACHINE'S PARAMETER AND LOAD-CELL (Extensometer) SETTING .....	58
Internal parameter setting description.....	59
LOAD CELL CALIBRATION .....	60
PID parameters (PRE-STRETCH MANAGE).....	61
TROUBLESHOOTING THROUGH INPUTS WORKING DISPLAY .....	62
LAYOUT MOTHER-BOARD AND I/O DESCRIPTION.....	63
TROUBLE-SHOOTING .....	64
GRAPHICAL DISPLAY OF STRETCH AND PRE-STRETCH VALUES .....	65
HIDEN FUNCTIONS .....	66
BATTERY CHARGER SPECIFICATIONS.....	69
TRACTION MOTOR BRAKE SETTING NOTIONS.....	71
PRODUCT HEIGHT DETECTION PHOTOCELL CALIBRATION.....	72
Standard photocell (for clear products).....	72
Dark product photocell (Datalogic model) .....	72
Dark product photocell (Sunx model).....	73

 <b>Norm. Tecn.</b> <b>60.2.49_05</b>	<b>TECHNICAL DOCUMENTATION</b> <b>- ROBOT S6 (Touch Screen Weintek Version) -</b>	<b>Date:</b> <b>July 2018</b>	<b>Rev.06</b>
	<b>ENGLISH</b>	<b>Pag. 5 / 86</b>	

POWER VOLTAGE TEST FOR SPOOL CARRIAGE CLUTCH / BRAKE .....74

ALARM LIST AND TROUBLE-SHOOTING .....75

ROBOPAC SECTION .....86

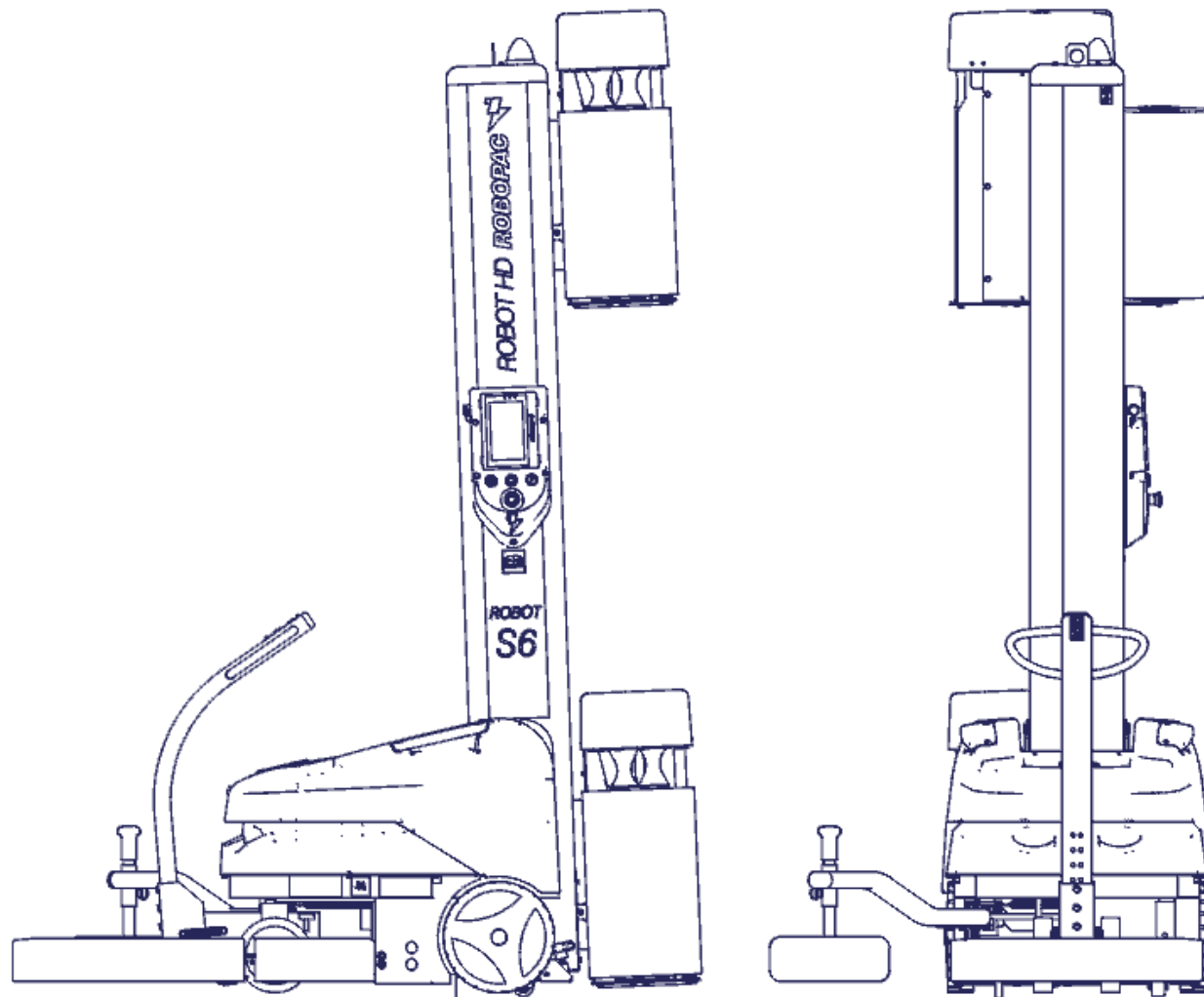
**MACHINE LAY-OUT**

**FILM SPOOL CARRIAGE DETAILED SKETCHES**

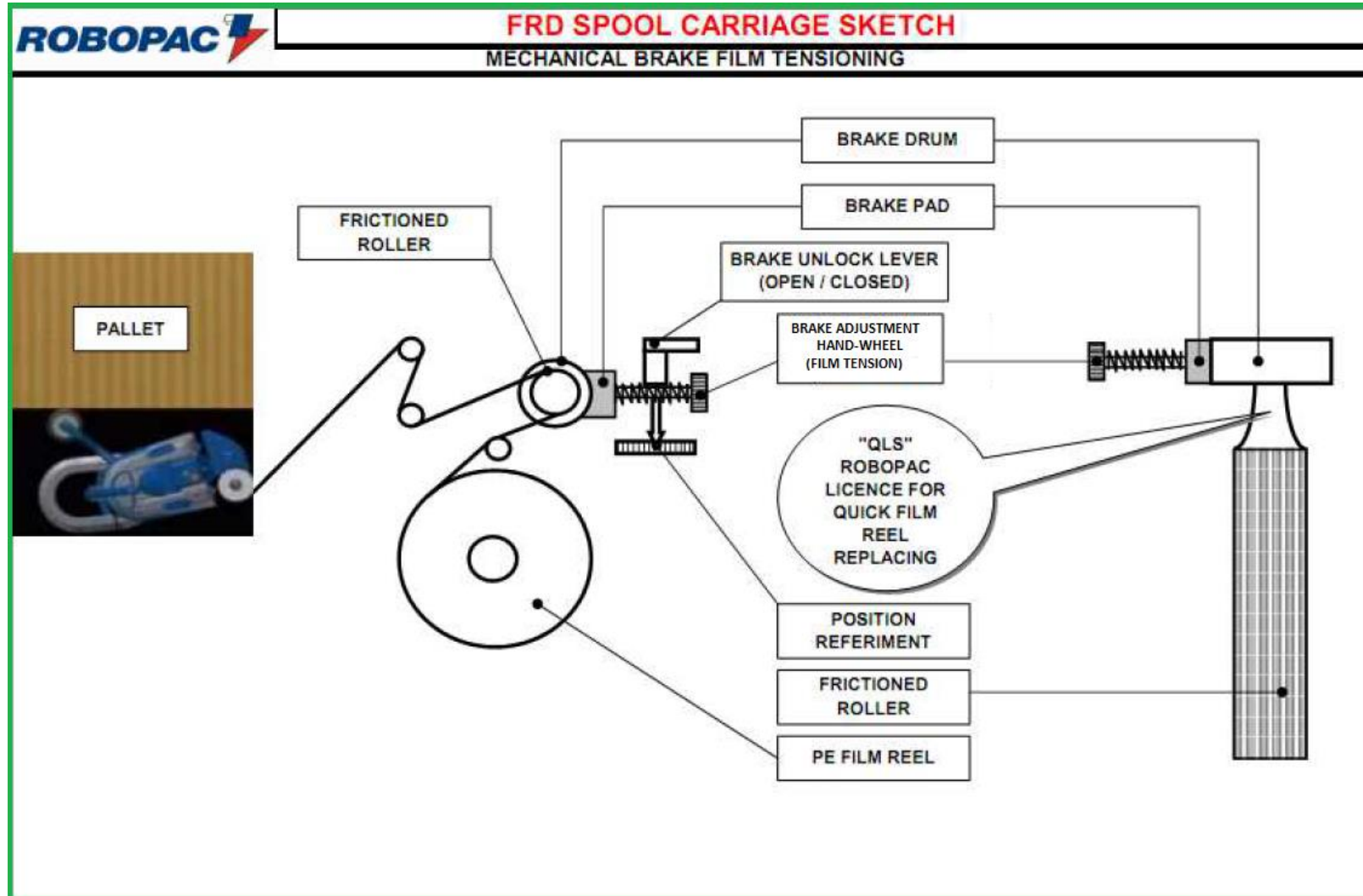

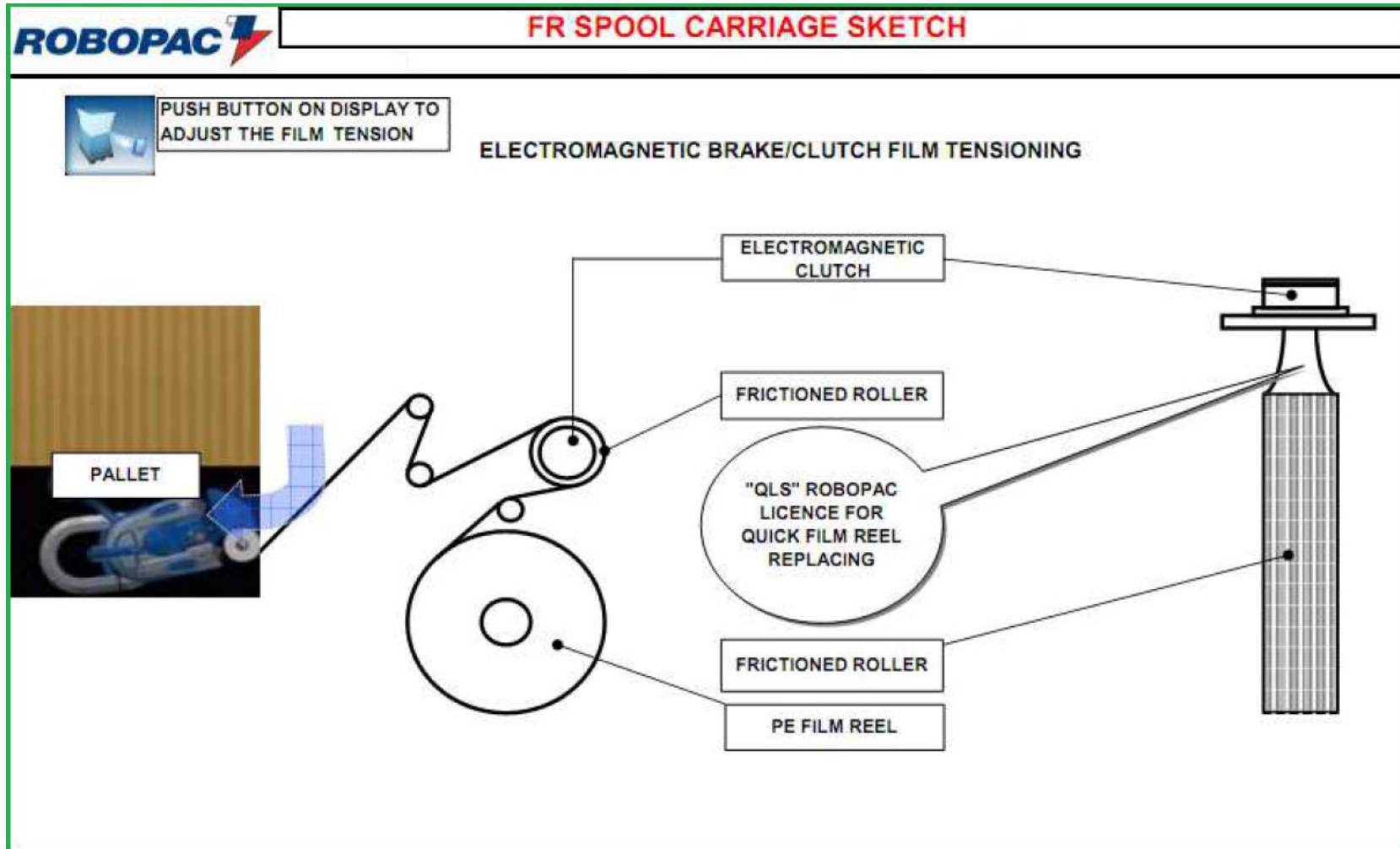

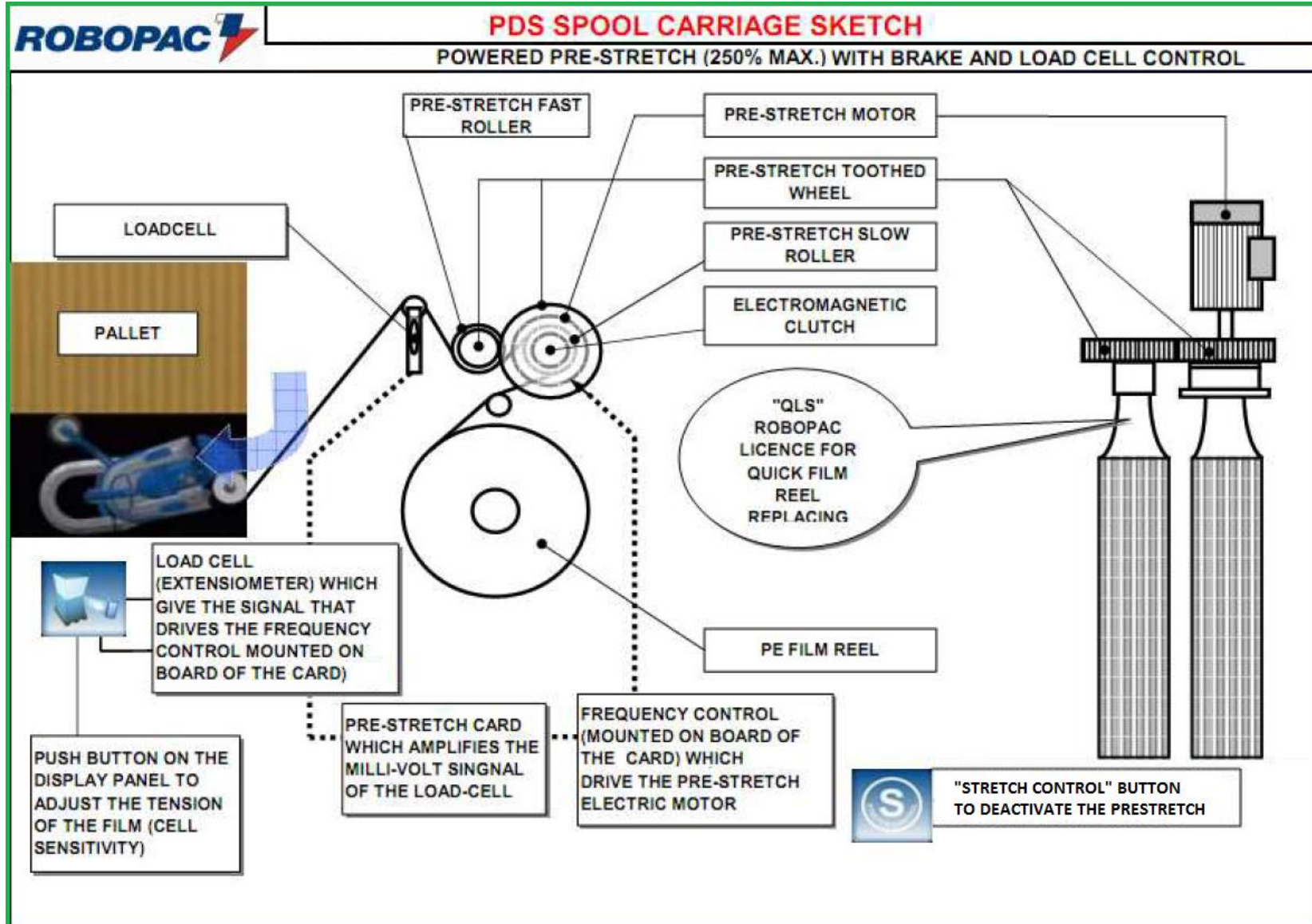

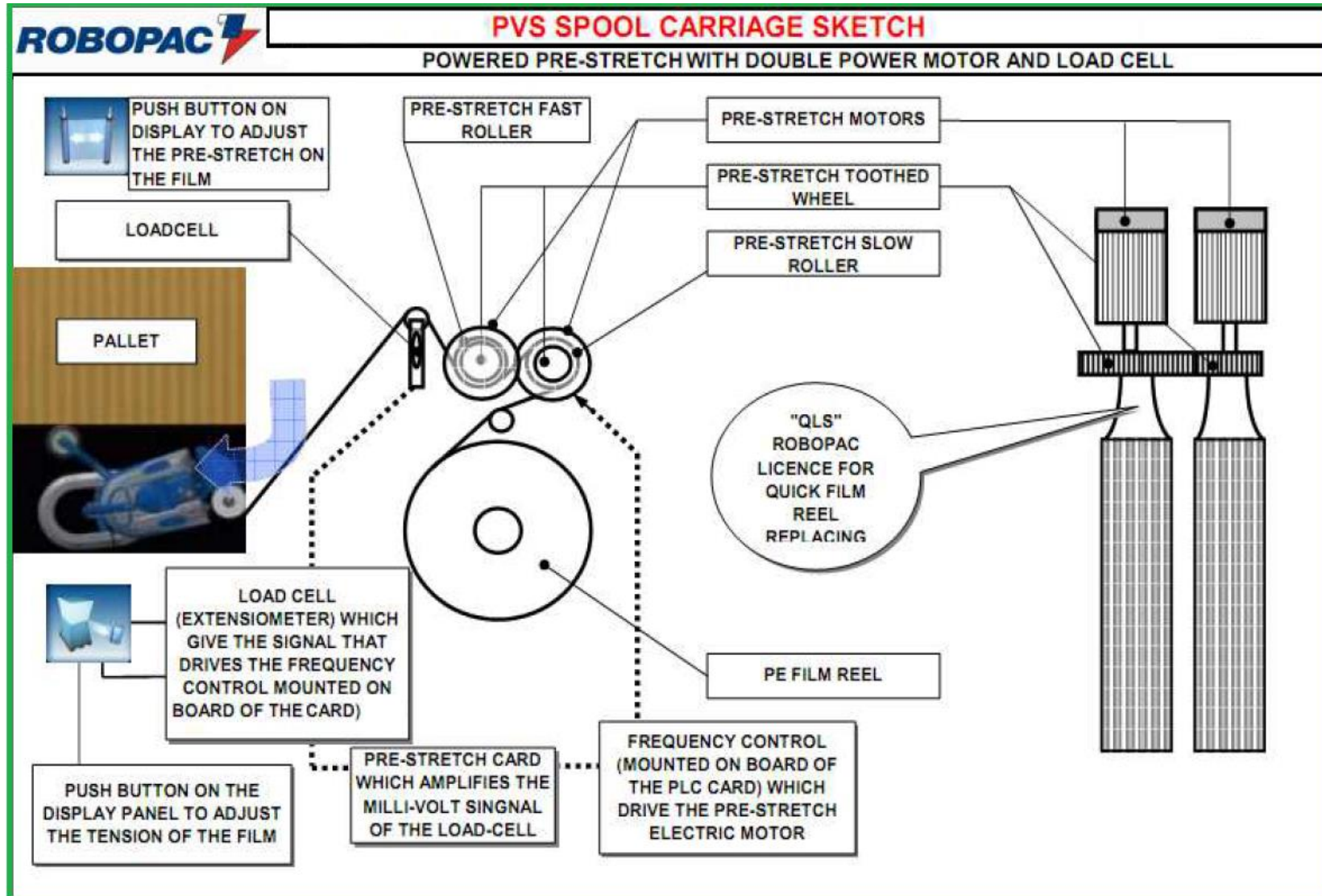

## OPERATOR PANEL DESCRITPION

		<b>ON / OFF push button</b>
		<b>RESET push button</b>
		<b>START push button</b>
		<b>EMERGENCY push button</b>

## BATTERY STATUS INDICATIONS DISPLAY

	Battery under charge
	Battery charge level 10% - E90 alarm
	Battery charge level 30%
	Battery charge level 80%
	Battery charge level 100%

## DESCRIPTION AND MAIN ELECTRICAL PANEL LAYOUT

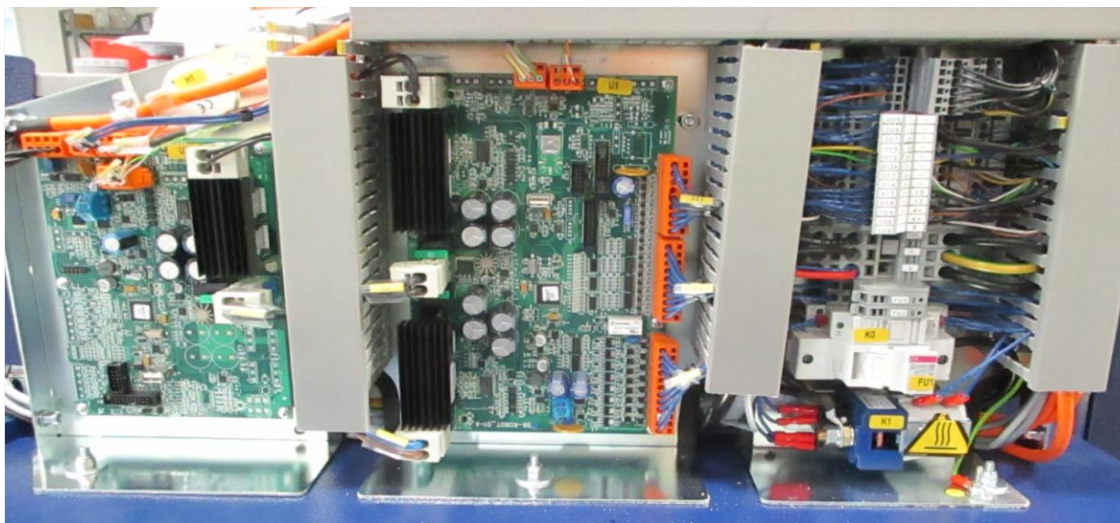
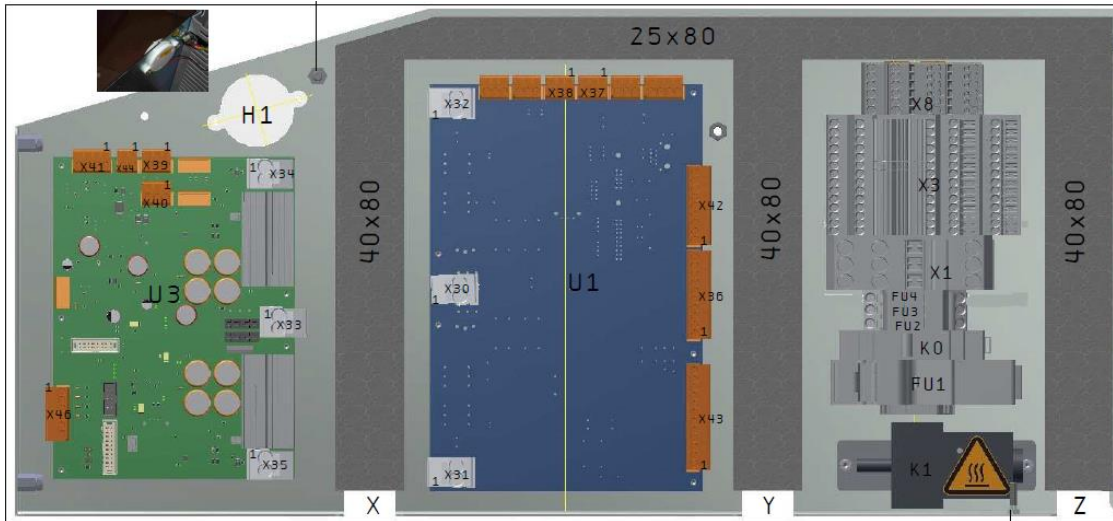

The part numbers are for information only.  
Always check and verify the codes on the wiring diagram supplied with the machine.

**U1** - ELETTRONICA ROBOT S6 Plc Card  
code 1430300180

**U3** - PRESTIRO 1M ROBOT S6 Pre-Stretch Inverter Card  
code 1430300198

**U3** - PRESTIRO 2M ROBOT S6 Pre-Stretch Inverter Card  
code 1430300181

**FU1** - Power Supply Fuse CILIND. 14X51 GG 50A 500V  
code 001304227

**FU2** - ChargeBattery Fuse MIN 5X20 RITARD. 4,000 AMP 250VAC  
code 001304080

**FU3** - Fuse MIN 5X20 RAP 2A 250VAC  
code 001304031

**FU4** - Fuse MIN 5X20 RITARD. 4,000 AMP 250VAC  
code 001304080

**K0** -ON/Off Relay RELE' IND. 24,0 VDC 20-22-9-024-00000  
code 001304323

**K1** -Emergency Contactor CONT.POT. ETL20PA  
code 0470300003

## ELECTRONIC CARDS DESCRIPTION

### PLC + INVERTER Card (Main Board) (U1)– CODE 1430300180

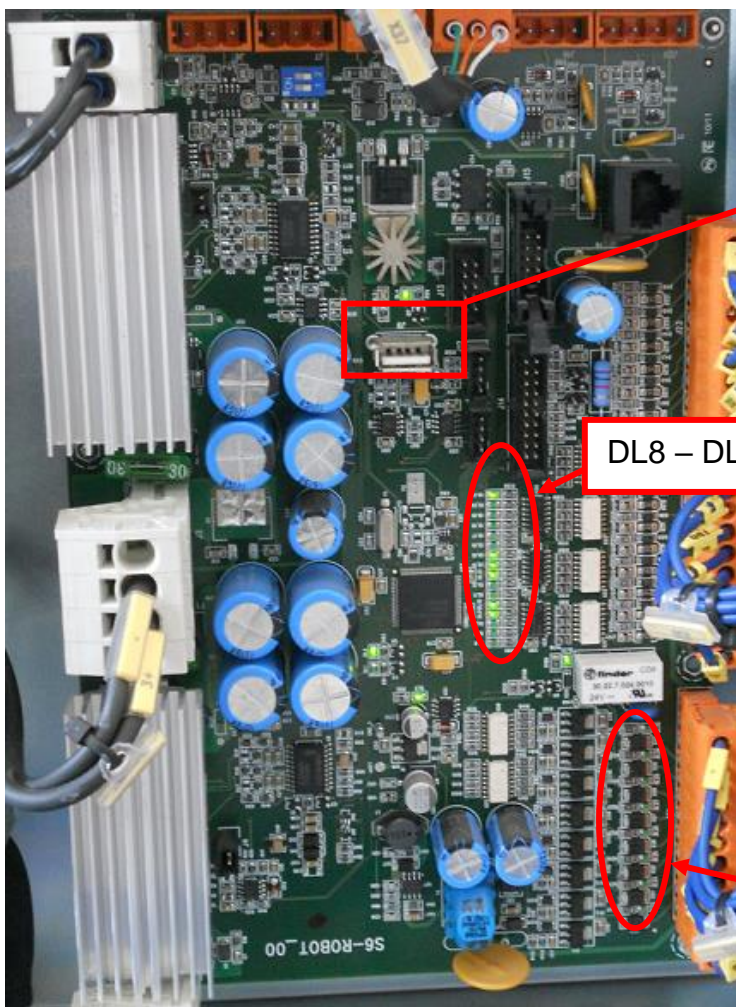

J10 USB port  
connection to  
download the  
software into the  
machine's  
mother-board

DL8 - DL23

DL25 - DL32

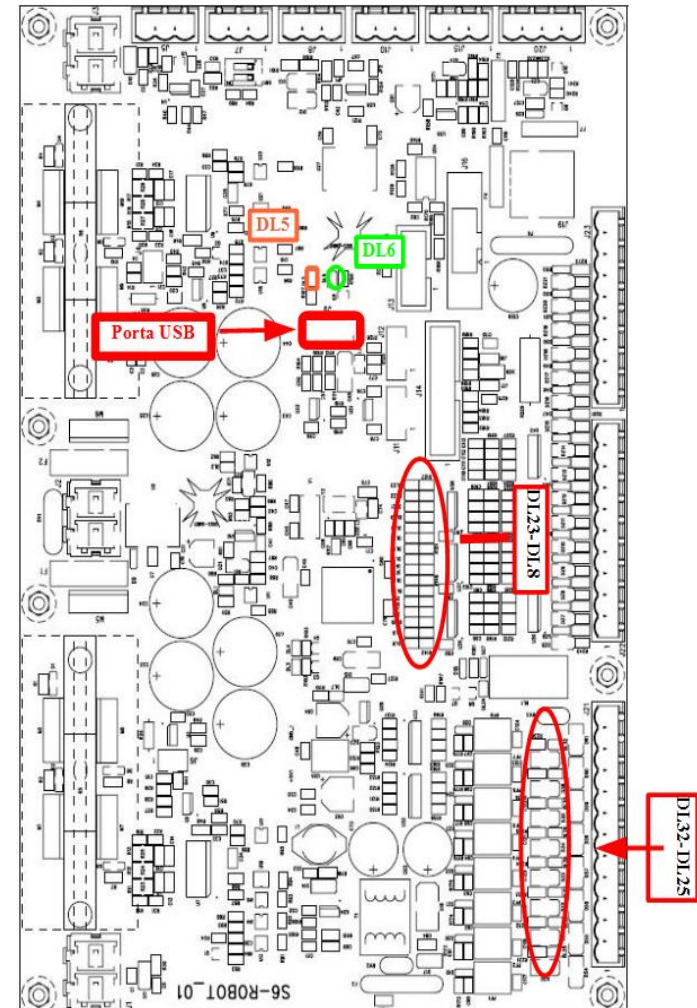

**X30/J2 Connector – Pin Table description**

Pin Number	Signal Description
1	Inverter Supply(+)
2	Inverter Supply(-)

**X31/J1 Connector – Pin Table description**

Pin Number	Signal Description
1	M1 Command Rotation Motor
2	M1 Command Rotation Motor

**X32/J3 Connector – Pin Table description**

Pin Number	Signal Description
1	M2 Command Rotation Motor
2	M2 Command Rotation Motor

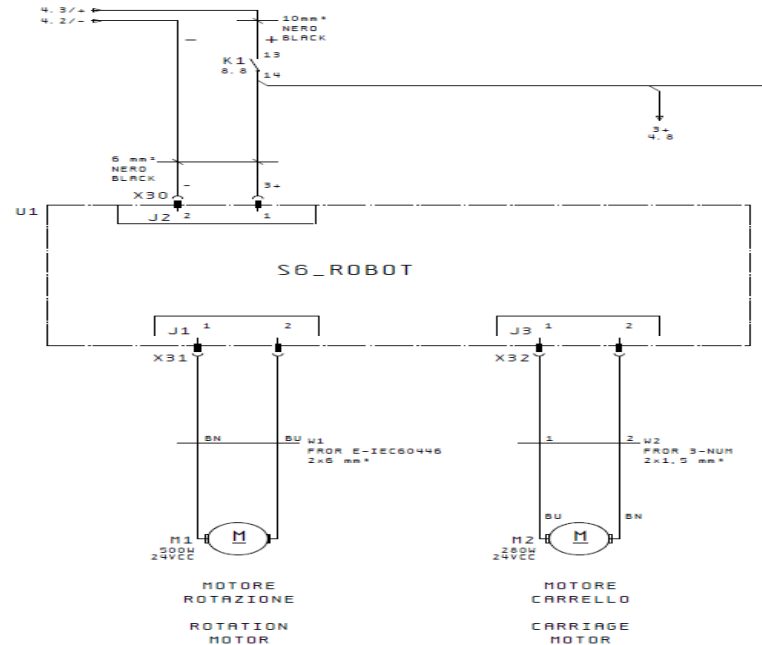

**X36/J22 Connector – Pin Table description**

Pin Number	Signal Description
1	CPU Supply(+)
2	CPU Supply(-)

**X37/J10 Connector – Pin Table description  
(Modbus Main Board – Touch Screen)**

Pin Number	Output Description
1	RS485 - A
2	RS485 - B
3	RS485 - GND

**X38/J8 Connector – Pin Table description  
(Modbus Main Board – Prestretch card) – (Modbus Main Board –Battery charger)**

Pin Number	Output description
1	RS485 - A
2	RS485 - B
3	RS485 - GND

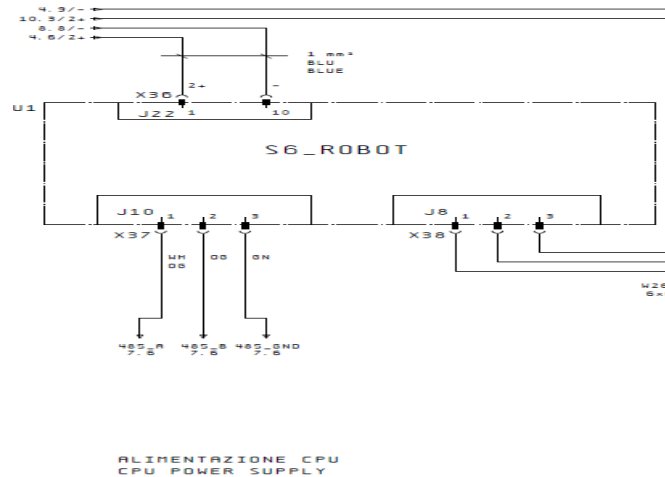

**X36/J22 e X42/J23 Connectors – Input Table description**

Input Number	Led Number	Input Description	Led State to Start	Contact type
In1	DL8	Emergency	OFF	N.O
In2	DL9	Start	OFF	N.O
In3	DL10	Reset	OFF	N.O
In4	DL11	Top limit switch	OFF	N.C
In5	DL12	Bottom limit switch	OFF	N.C
In6	DL13	Photocell detection product	ON	N.O
In7	DL14	Free		
In8	DL15	Counter corners sensor	OFF	N.O
In9	DL16	Emergency chain	ON	N.O
In10	DL17	Bumper emergency	OFF	N.C
In11	DL18	Manual forward	OFF	N.O
In12	DL19	Manual backward	OFF	N.O
In13	DL20	Film break (FRD-FR-FS carriages) or Film unwind push button (PVS carriage)	OFF	N.O
In14	DL21	Free	OFF	N.O
In15	DL22	Free		
In16	DL23	UP/DOWN carriage motor sensor (encoder)	OFF	N.O

**X43/J21 Connectors – Output Table description**

Output Number	Led Number	Output description
Out1	DL25	Power save function
Out2	DL26	Traction brake
Out3	DL27	Film cut (Optional)
Out4	DL28	Beeper
Out5	DL29	Blinker
Out6	DL30	Free
Out7	DL31	Free
Out8	DL32	Brake / Clutche (Fr-Fs-Pds Carriages)

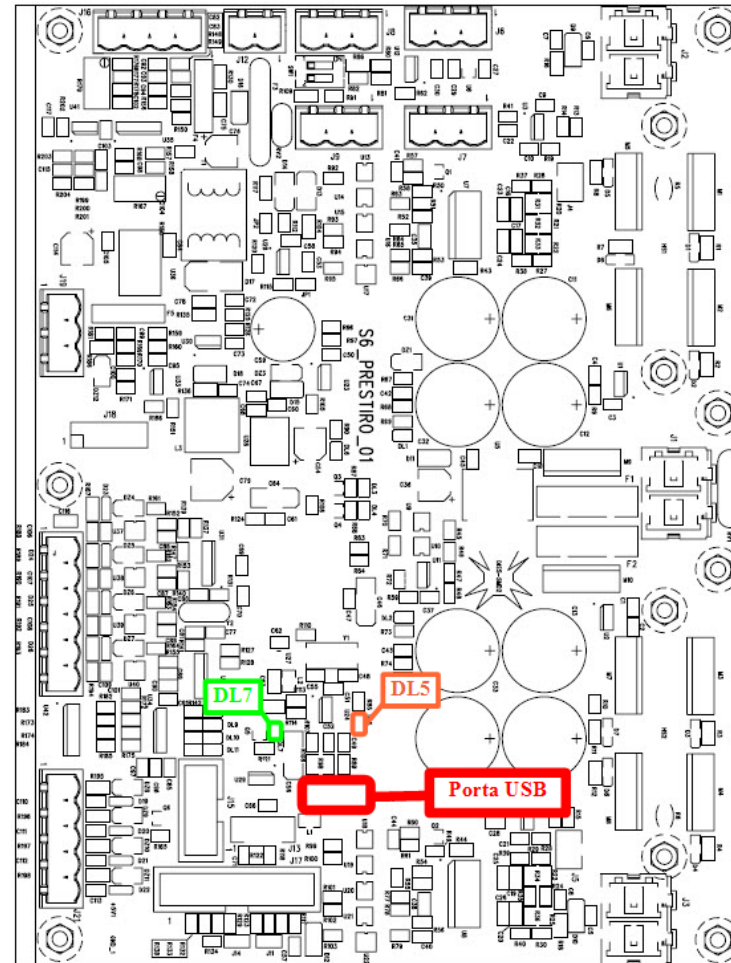
**Pre-stretch Card 1 Motor (U3) – CODE 1430300198**

**X33/J1 – Connector – Pin Table description**

Pin Number	Signal Description
1	Inverter Supply(+)
2	Inverter Supply(-)

**X34/J2 Connector – Pin Table description**

Pin Number	Signal Description
1	M3 Command Stretch Motor
2	M3 Command Stretch Motor

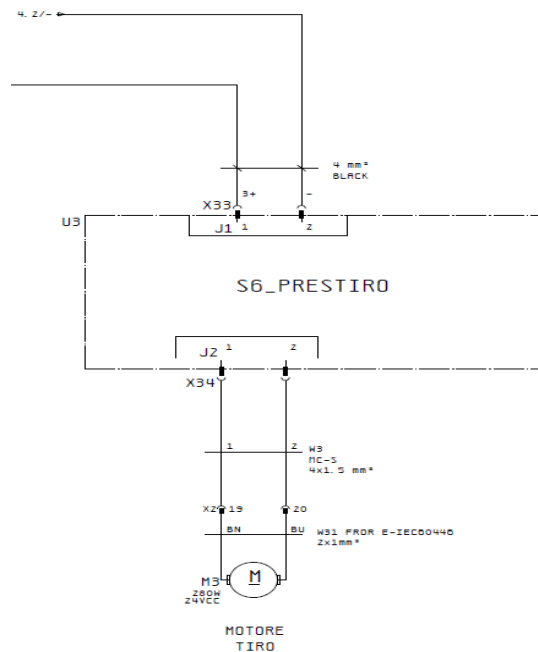



Pre-stretch Card 2 Motors (U3) – CODE 1430300181

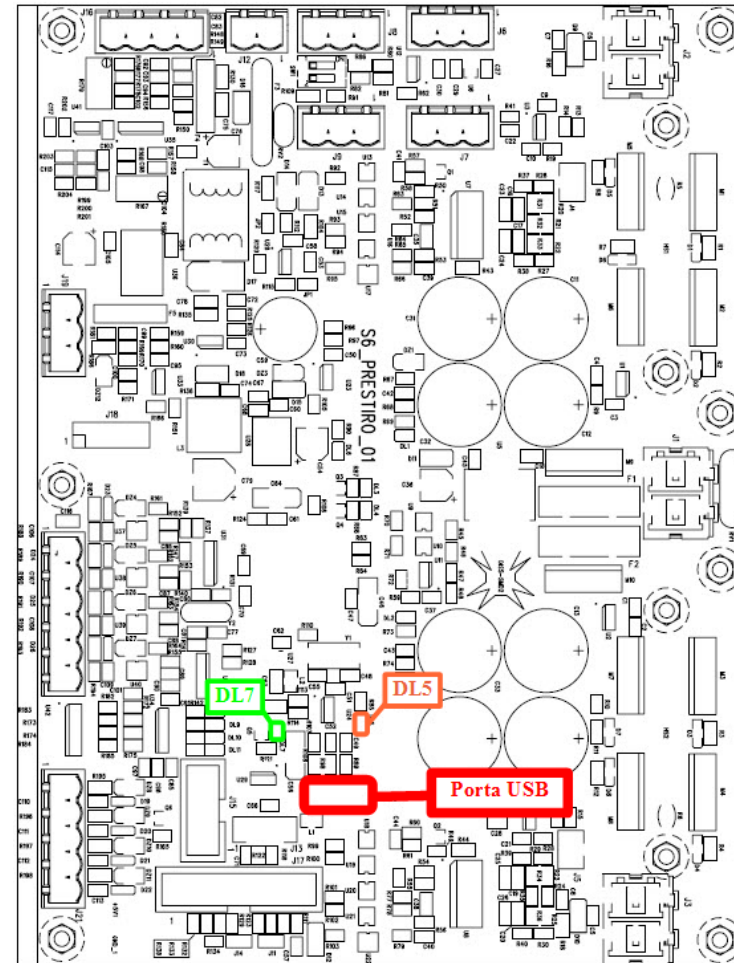

**X33/J1 – Connector – Pin Table description**

Pin Number	Signal Description
1	Inverter Supply(+)
2	Inverter Supply(-)

**X34/J2 Connector – Pin Table description**

Pin Number	Signal Description
1	M3 Command Stretch Motor (Fast Roll)
2	M3 Command Stretch Motor (Fast Roll)

**X35/J3 Connector – Pin Table description**

Pin Number	Signal Description
1	M4 Command Pre-Stretch Motor (Slow Roller)
2	M4 Command Pre-Stretch Motor (Slow Roller)

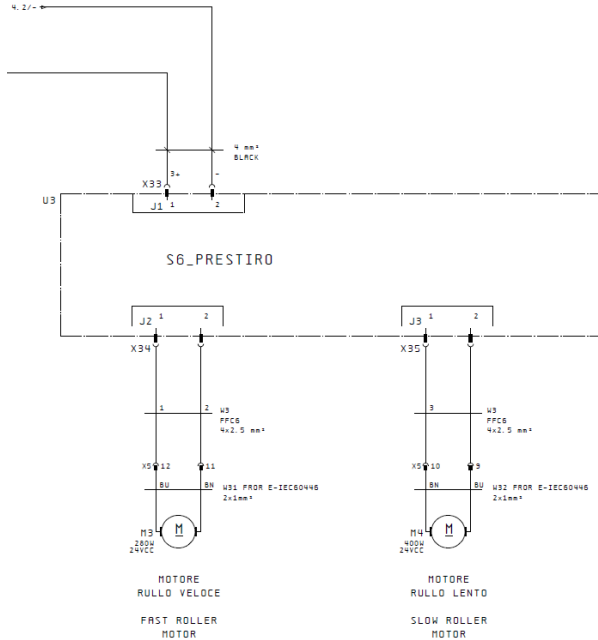

 <b>Norm. Tecn.</b> <b>60.2.49_05</b>	<b>TECHNICAL DOCUMENTATION</b> <b>- ROBOT S6 (Touch Screen Weintek Version) -</b>	<b>Date:</b> <b>July 2018</b>	<b>Rev.06</b>
	<b>ENGLISH</b>	<b>Pag. 22 / 86</b>	













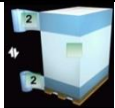

### **POWER SAVE” FUNCTION (MACHINE STAND-BY)**

If the machine doesn't run for a period of 15 minutes (the machine doesn't make packing and nobody touch the operator panel) it switch to the "power save" mode. In this condition, the output relay "emergency" (so, the contactor K1 disconnects) and the touch-panel switch to stand by mode too (dark screen). To exit from this condition, it is just necessary to touch any part of the screen or the RESET push button.

### **“POWER SAVE” FUNCTION (MACHINE SHUTDOWN)**

If other 45 minutes run after the "POWER SAVE" mode without nobody plays with the machine, it TURN OFF automatically and the white lamp of the ON/OFF push button will switch off too. To re-start the machine, it is just necessary to press the ON/OFF push button. This function grant a longer life and better performance of the battery.

## LIST OF RECIPES DATA

Parameter		Min. – Max.	Step	Unit of measure / Notes		
Type of packaging cycle		Up and Down cycle				
		Up only cycle or Down only cycle				
		Top sheet cycle				
		Packaging Cycle with automatic cutting	Option activation	<b>ON</b> BLUE COLOURED BUTTON	<b>OFF</b> GREY COLOURED BUTTON	
Bottom wraps		0 – 20	1	Giri		
Top wraps		0 – 20	1	Giri		
Photocell delay		0 – 100	1	cm		
Ground Offset		0 – 300	1	cm		
Reinforcement height and reinforcement wraps		 310 cm	0 -- 310	1	cm	
		 20 N.	0 – 20	1	Giri	
Arm Rotation speed		35 – 80	1	giri/minuto		
Carriage up/down speed			1.5 – 5.0	0.1	m/minuto	
			1.5 – 5.0			
Altimeter		0 – 310	1	cm		



Norm. Tecn.  
60.2.49\_05

**TECHNICAL DOCUMENTATION**  
**- ROBOT S6 (Touch Screen Weintek Version) -**

Date:  
July 2018

Rev.06

ENGLISH

Pag. 24 / 86

**FRD CARRIAGE**

Film Drive– Manual adjustment				Dimensionless
-------------------------------	--	--	--	---------------

**FR CARRIAGE**

Film Drive		0 – 100	1	Dimensionless
------------	---	---------	---	---------------

**FS CARRIAGE**

Film pre-stretch		0 – 200	10	%
------------------	---	---------	----	---

**PDS CARRIAGE**

Film Drive		0 – 100	1	Dimensionless
Film pre-stretch		0 – 25 (0 – 250)	10	%



**Stretch control off.**  
**Stretch control off.**  
Pre-stretch is always set to maximum. The obtained pre-stretch depends on the gear ratio applied on the carriage (200% - 250% - 300%).

Standard operations includes 250% maximum applied pre-stretch.

While pressing for about 4 sec.

the icon enables the management of the shot into 4 values (Bottom wraps – Carriage up - Top wraps – Carriage down)

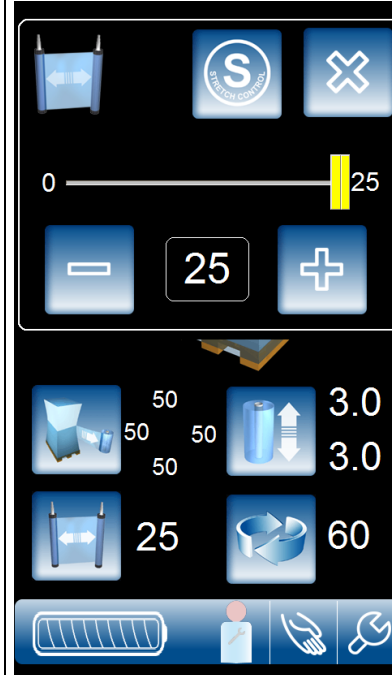
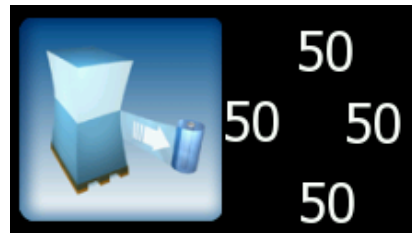

**Stretch control on.**  
It's possible to DEACTIVATE the prestretch. With values from 0 to 6/7/8/9 (it depends on many elements) the prestretch is DEACTIVATED, with values over that value the Prestretch is ACTIVATED  
The obtained pre-stretch depends on the gear ratio applied on the carriage (200% - 250% - 300%). Standard operations includes 250% maximum applied pre-stretch.

While pressing for about 4 sec.

the icon enables the management of the pre-stretch into 4 values (Bottom wraps – Carriage up - Top wraps – Carriage down)



**PVS CARRIAGE**

Film Drive		0 – 100	1	Dimensionless
Film pre-stretch		0 -- 400	10	%



Enabling Special packaging cycles

- DISABLED FUNCTION → ICON GREY BACKGROUND.
- FUNCTION ENABLED ICON BACKGROUND BLUE



Cycle standard packing with bottom wraps at end of cycle (SPECIAL CYCLE DISABLED – icon background color gray)



Special packing cycle for huge dimensions perimetral products (CICLE DISABLED – background icon blue color)



Special packing cycle for cylindrical or smaller dimension fo minimum size 60 x 60 cm (CICLE DISABLED – background icon blue color)



Icon to view the selected packing cycle. Pressing on “+” or “-“, it is possible to scroll all the set packing cycle to run the appropriate one for the product to pack

Packing cycle for huge dimensions products (F1 cycle):



Up-ward movement value film spool carriage upon every packing round







Packing cycle for cylindrical products or smaller dimension fo minimum size 60 x 60 cm (F2 cycle):



Product diameter selection for circular product, or diagonal setting for small products

 <b>Norm. Tecn.</b> <b>60.2.49_05</b>	<b>TECHNICAL DOCUMENTATION</b> <b>- ROBOT S6 (Touch Screen Weintek Version) -</b>	<b>Date:</b> <b>July 2018</b>	<b>Rev.06</b>
<b>ENGLISH</b>		<b>Pag. 27 / 86</b>	

## GENERAL FUNCTIONS AVAILABLE ON TOUCH-PANEL

	Enable manual functions
	Close window
	Instruments
	Information
	Back to previous page
	Back to Main page

## HOW TO USE THE ACCESS PASSWORD OF THE OPERATOR TOUCH-PANEL

To apply the password by operator panel to access the required section, follow the next procedure:



By Main page (the one that appear on machine start-up), press the icon "INSTRUMENTS ".



By applications page, press icon "ACCOUNT ".



By account page, press icon "USER " till visualize on the screen the icon of the related user (please refer to below's specifications).







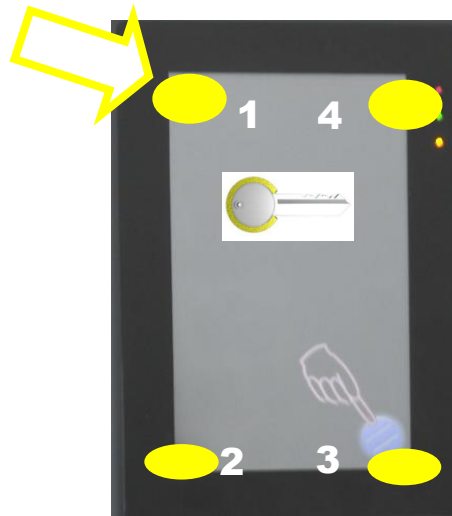





### Procedure to reset the "USER ACCOUNT" password to default.

If you forget the first level password (**operator USER ACCOUNT**), it is possible to RESET it to the default (**1111**) like producer setting.

Turn the machine ON in the RESET page, and within 5 seconds, press in counter-clockwise sequence the four corners of the touch panel starting from top left corner (see below sketch). As soon the operation will be complete, the operator panel will give an acoustic signal and will display for few seconds a key that will show the default password (**1111**) as shown in below sketch.



When the key with password **1111** is displayed on the touch panel, you'll be sure that the password has been reset to DEFAULT.

<p><b>OPERATOR AND END USER MACHINE'S RESPONSIBLE SECTION</b></p>	<div style="display: flex; justify-content: space-around;"> <div style="text-align: center;">    </div> <div> <p>None password of access to the higher users levels.. Touch-screen operator panle locked,</p> </div> </div> <hr/> <div style="display: flex; justify-content: space-around;"> <div style="text-align: center;">    </div> <div> <p><b><u>USER SECTION</u></b> (Responsible / Machine's user) Password = 1111</p> </div> </div>	<div style="text-align: center;">   <p>Machine's packing mode</p> </div>
<p>Use of the machine limited to the setting of the packing cycle and setting of a different access password</p>		
<p><b>ROBOPAC's DISTRIBUTOR SECTION</b></p>	<div style="display: flex; justify-content: space-around;"> <div style="text-align: center;">    </div> <div> <p>Insert the flash USB key memory which contins the access file</p> </div> <div style="text-align: center;">   <p>Press on "CANCEL" to continue the login</p> </div> <div style="text-align: center;">  </div> </div> <div style="margin-top: 20px;"> <p><b><u>DISTRIBUTOR SERVICEMAN SECTION (MACHINE'S MAINTENANCE)</u></b> (Robopac's distributor) Password = 6161</p> </div>	<div style="text-align: center;">   <p>Distributor's serviceman password confirmation.</p> </div>
<p>Use of the machine like "USER" and access to the main functions of service for diagnostics and maintenance.</p>		
<p><b>ROBOPAC SECTION</b></p>	<div style="display: flex; justify-content: space-around;"> <div style="text-align: center;">  </div> <div> <p><b><u>ROBOPAC SERVICEMAN SECTION</u></b></p> <p>To be used by ROBOPAC's service engineers only</p> </div> </div>	<div style="text-align: center;">   <p>ROBOPAC's serviceman password confirmation.</p> </div>

## MACHINE'S END-USER SECTION



OPERATOR'S TOUCH-PANEL  
GENERAL SETTINGS  
FUNCTIONS

### Active functions without password inserted

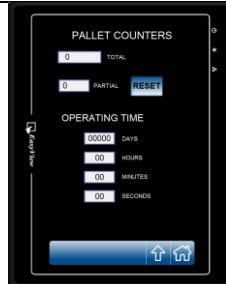

Packed product counter  
display (production control)

**RESETTING VALUES NOT  
POSSIBLE**

### Active functions with password inserted

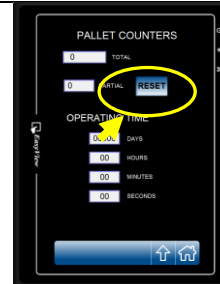

Inserting the password  
**1111**, it is possible to  
reset the partial packing  
counter (production  
control).



**View of:**

- Softwares installed on the machine
- Touch panel locked / un-locked
- Operator panel language set
- Date / time
- Acoustic signal buttons on operator panel ON / OFF

**MODIFICATION NOT POSSIBLE**

2

- SW Release main board (PLC)
- SW Release Pre-stretch card (when installed)
- SW Release touch screen (HMI)
- Main Board board serial number (PLC)
- Pre-stretch card serial number (when installed)

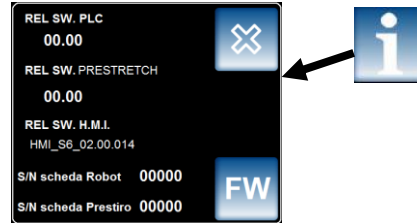

Fw Version Touch-screen



Inserting the password **1111** it is possible to modify the following settings:



Touch-panel locking / Un- locking



Touch panel language setting



Time / Date setting

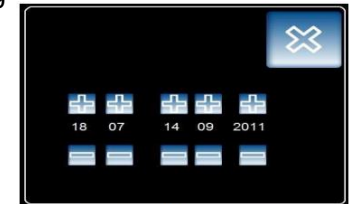

h m dd mm yyyy



Acoustic signal buttons on operator panel ON / OFF



First level password modification only

3



**View of:**

- Level battery status
- Alarm history
- Internal parameter list
- I / O (input / output) conditions
- State / condition ModBus protocol

**MODIFICATION NOT POSSIBLE**

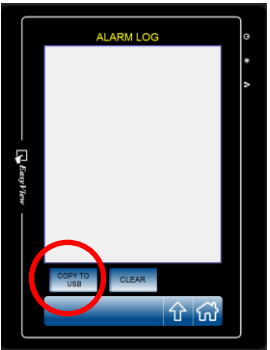

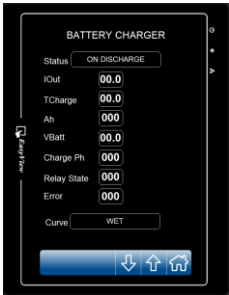

Setting the appropriate password it is possible to view the alarm history list and copy them on a USB pen-drive by pressing the button .



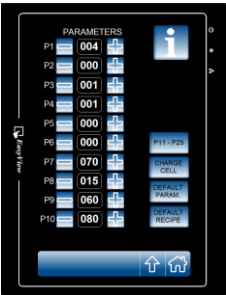

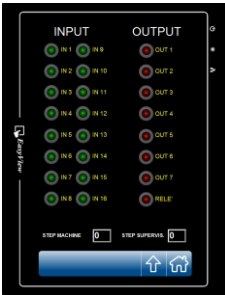





Level battery status page

Alarm history page

Internal parameter list page

I / O (input / output state) page

By setting the password, you can delete the list of alarm history by pressing the button .

Active functions with  
operator touch panel locked



Active functions with  
Operator touch panel unlocked



AVAILABLE FUNCTIONS  
ON OPERATOR TOUCH  
PANEL IN LOCKED OR  
UNLOCKED MODE

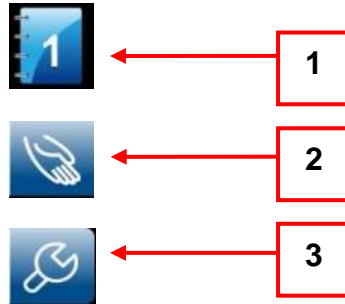

Press this icon to access the set packing programs (refer to sketch on side of the recipes).  
On each packing program, it is possible to set all the cycle values desired



Recipes lists to set packing programs

Packing cycle set on the selected recipes

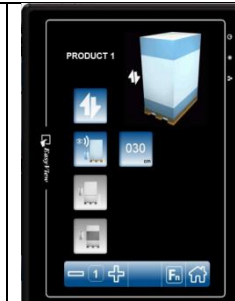

Details of the packing cycle values set (packing) suitable for each product (recipe)

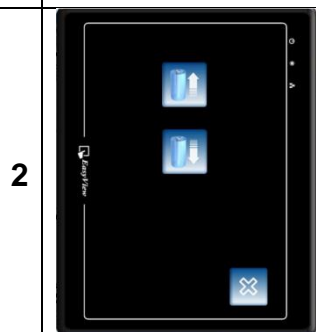

Manual carriage up-ward



Manual carriage down-ward

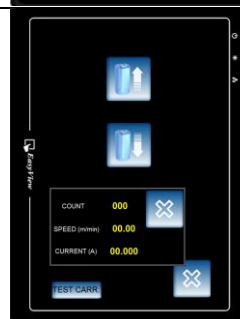

Function to enable the test of film spool carriage speed

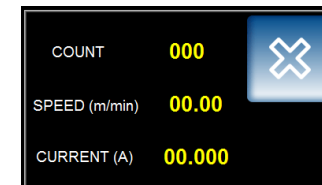

Window which shows the speed of film spool carriage (mt/min)

3



Press this icon to go back to the main page to access machine's internal parameter



## PACKING PARAMETER SETTING

(modifiable when operator touch panel UNLOCKED only)



To access the cycle parameters section, press the center of the icon which shows the pallet.



Up / Down packing cycle

Alternating packing cycle (up-ward only / down-ward only)

Top sheet cycle

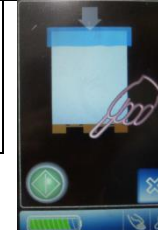

Indication to re-start the cycle after top application above the product



Film automatic cutting (blue = ENABLED / grey = DISABLED)

### Packing cycle parameters description

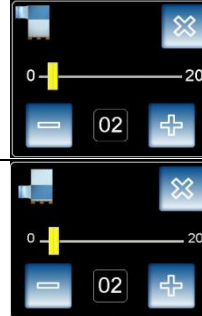
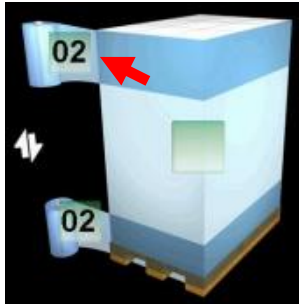

Press on the icon of the touch-panel in the section shown with the red arrow, it is possible to enable the function to set the number of top over-wraps (pressing in the bottom position it is possible to set the number of bottom over-wraps) during the packing cycle.



Icon to adjust FILM STRETCH (display on machines equipped of FR/PDS/PVS film carriage only)

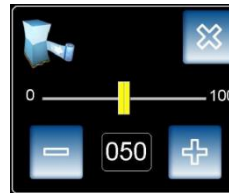

Window to set the film tension (stretch)













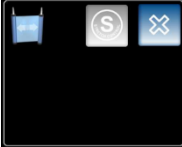
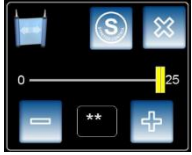
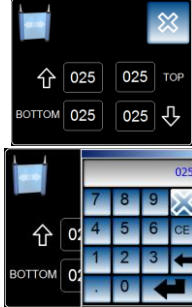

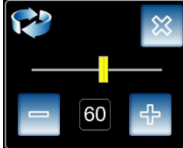



Windows to set multiple film stretch (bottom wraps / top wraps / upward carriage / downward carriage) enabling by keeping pressed the icon  for about 4 seconds



Icona to adjust the UP / DOWN FILM SPOOL CARRIAGE SPEED.



Page to set the film carriage speed (up-ward and down-ward)

	<p>Icon to adjust FILM PRE-STRETCH (display on machines equipped of FS/PDS/PVS film carriage only)</p>	 <p>Selection for fix pre-stretch or variable pre-stretch</p>	 <p>Variable pre-stretch setting window (adimensional values)</p>  <p>Windows to set multiple film pre-stretch (bottom wraps / top wraps / upward carriage / downward carriage) enabling by keeping pressed the icon  for about 4 seconds</p>
	<p>Icon to adjust machine's TRACTION SPEED</p>	 <p>Window to set the speed of the machine (mt/min)</p>	
	<p>Icon PHOTOCELL DELAY</p>		 <p>Press on these icons to set the desired photocell delay setting to adjust the film overlap on top of pallet</p>
	<p>Icon ALTIMETER</p>		 <p>Press these icons to set the maximum desired high that film spool carriage has to reach (photocell excluded) like altimeter setting</p>
	 <p>Offset from ground (ENABLED))</p>		 <p>Press these icons to set the offset from ground value (to pack starting from a different level then ground)</p>
	 <p>High and reinforcement wraps number (ENABLED)</p>		 <p>Press these icons to set the level from ground and the number of reinforcement wraps to perform on</p>



Special packing cycles selection:

- DISABLED FUNCTION → GREY BACKGROUND ICON.
- ENABLED FUNCTION → BLUE BACKGROUND ICON



Standard packing cycle  
(CICLE DISABLED – background icon grey color)



Special packing cycle for huge dimensions perimetral products  
(CICLE DISABLED – background icon blue color)



Special packing cycle for cylindrical or smaller dimension fo minimum size 60 x 60 cm (CICLE DISABLED – background icon blue color)



Icon to view the selected packing cycle. Pressing on “+” or “-”, it is possible to scroll all the set packing cycle to run the appropriate one for the product to pack.

Packing cycle for huge dimensions products (F1 cycle):



Up-ward movement value film spool carriage upon every packing round

Packing cycle for cylindrical products or smaller dimension fo minimum size 60 x 60 cm (F2 cycle):



Product diameter selection for circular product, or diagonal setting for small products

Packing cycle setting recording



Press on recipe icon access



Press on name of the recipe to store the new packing cycle setting and re-name



Using the alphanumeric keyboard to insert or rename the recipe (packing program)



## BATTERY TEST CONDITION FUNCTION

(this function is available when the operator touch panel is locked)

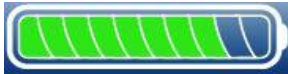

Pressing the icon “battery status” on the pages where it is shown, it opens the windows shown on the side, where it is shown the voltage given by the battery measured by the mother-board of the machine. Check the battery voltage and compare it with the voltage got by the multi-tester instrument. Tolerance  $\pm 0,1V$



## MANUAL FORWARD SPEED ADJUSTMENT FUNCTION

It is possible to adjust the forward speed of the machine in manual mode. Keeping pressed the push button of **manual forward** and then, pressing the push button of **manual backward**, will be possible to increase the manual forward speed of the machine. For each press of the **manual backward** push button, the speed will be increased of one “step” till reaching six increased speeds. Releasing the manual forward push button, at next manual run, the speed of the machine will be restored to the minimum speed forward. This function is available to adjust the forward speed, not the backward speed.

## SERVICE SECTION (MACCHINE MAINTENANCE)



All the functions described in the paragraph “**MACHINE’S END-USER SECTION**” can be used by serviceman (distributor engineer) using his **6161**.

### INTRODUCTION:

In case of replacement of the touch-panel, mother-board or pre-stretch card, or in case of software updating of one of the three cards mentioned above, it will be necessary to download the new software on all the three cards (please refer to below procedure).

The original machine’s software of the three cards, made during machine’s internal testing before shipment, are included into a flash memory USB bagged into the technical envelope together the technical documentation of the machine inside the battery lodge.





**TOUCH-SCREEN PANEL SETTING AND DOWNLOAD****TOUCH-SCREEN PANEL SETTING (Weintek MT6070iH model)**

Here below are indicated all the necessary information for the maintenance of the machine and all the accessible functions by service.

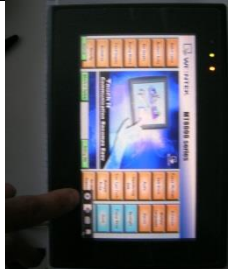

1. Turn-ON the machine till display the page the page shown on the side.
2. Press the button  to bottom on the left.



3. Press the button  as shown on side sketch.



4. Insert the instrument password: **11111** and press the button OK.



5. Select from menu "***Firmware setting***", ad shown by red arrow



6. Select 90 and press the button OK.
7. Turn OFF and turn ON again the machine

**TOUCH-SCREEN PANEL SOFTWARE DOWNLOAD PROCEDURE (Weintek MT6070iH model)**



1. Turn the machine ON.
2. Insert the USB pen drive into the related slot.



3. Wait a bit of time till display the page on the shown on the side:
4. Press the button **“Download”** (press it within 10 seconds upon the windows appear, due past that time, the windows closes. The time remaining to windows closing, it is displayed like *“Time remaining”*).



5. Insert the password: **111111**, select the options:
  - “Download project files” ---> YES
  - “Download history files” ---> NO
 then press button OK.



6. Select the folder **disk\_a\_1** as shown in the sketch on the side (usbdisk\disk\_a\_1).
7. Press the button **OK**.

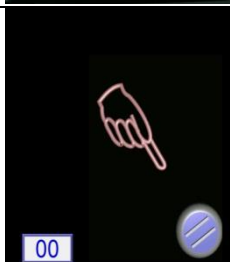

1. Completed the download, wait for software re-start till display the message **RESET**:

**TOUCH-SCREEN PANEL SETTING (Weintek MT8071iE model)**

Here below are indicated all the necessary information for the maintenance of the machine and all the accessible functions by service.



1. Turn-ON the machine till display the page the page shown on the side.
2. Press the button  to bottom on the left.

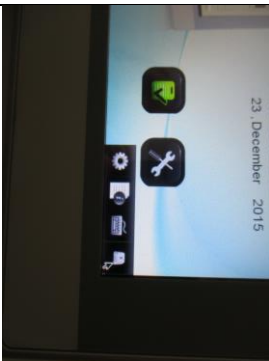

3. Press the button  as shown on side sketch.

**To work more easily hold the horizontal panel**

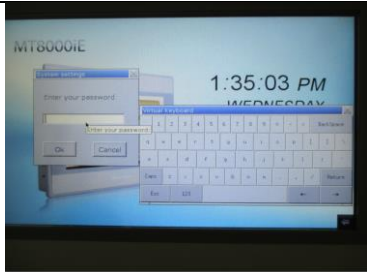

4. Insert the instrument password: **111111** and press the button OK.

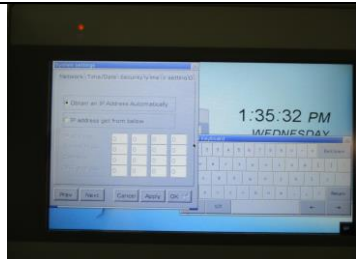

5. Screen will be displayed "**System setting**".

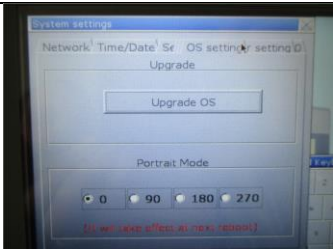

Select from menu "**OS setting**", as shown by red arrow

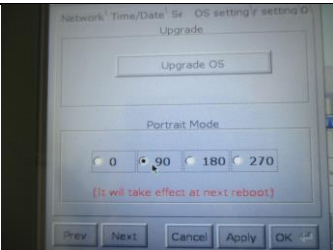

6. Select 90 and press the button OK.  
7. Turn OFF and turn ON again the machine

**With this procedure we set the display of the vertical panel.**

**TOUCH-SCREEN PANNEL SOFTWARE DOWNLOAD PROCEDURE (Weintek MT8071iE model)**

3. Turn the machine ON.



4. Insert the USB pen drive into the related slot.

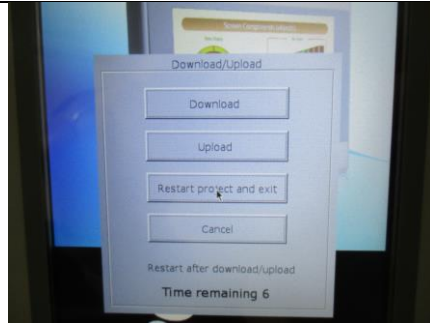

3. Wait a bit of time till display the page on the shown on the side:
4. Press the button **“Download”** (press it within 10 seconds upon the windows appear, due past that time, the windows closes. The time remaining to windows closing, it is displayed like *“Time remaining”*).

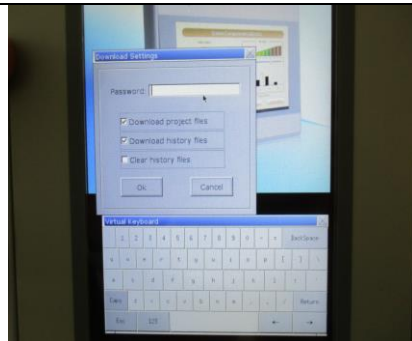

5. Insert the password: **111111**, select the options:
  - “Download project files” ---> SI
  - “Download history files” ---> NOthen press button **OK**.



6. Select the folder **disk\_a\_1** as shown in the sketch on the side (usbdisk\disk\_a\_1).
7. Press the button **OK**.



8. Wait for the software download.

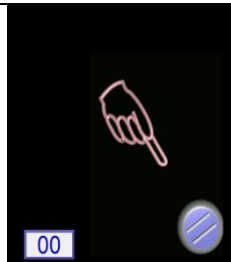

Completed the download, wait for software re-start till display the message **RESET**:

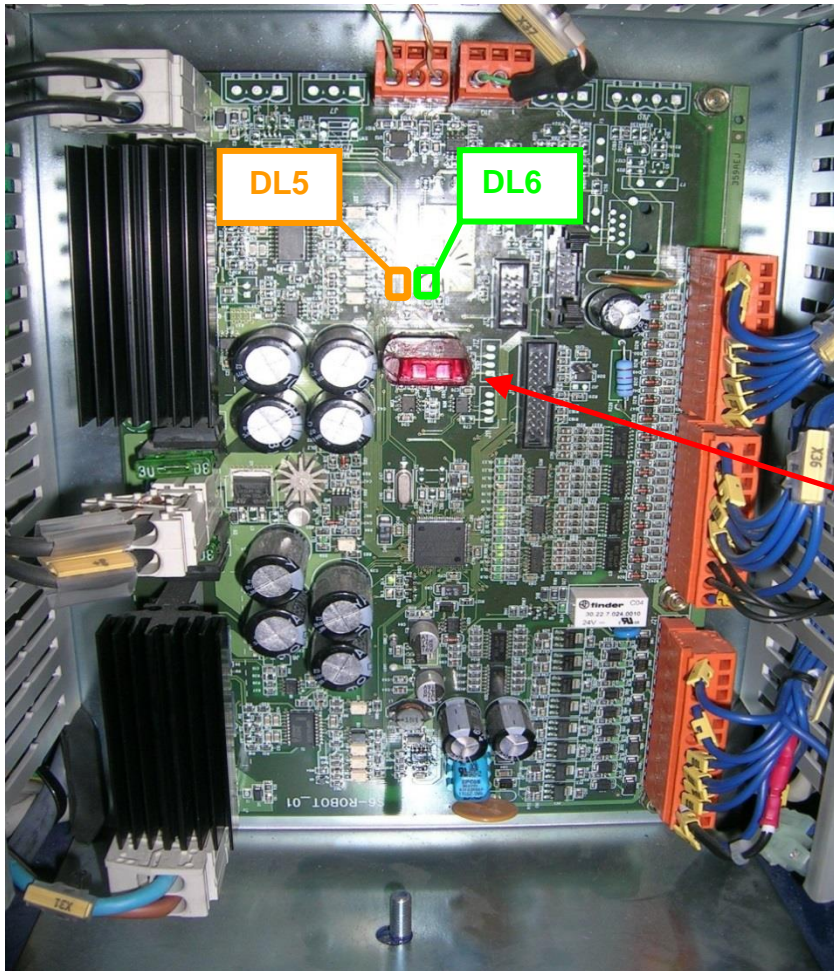
**MOTHER-BOARD (U1) SOFTWARE DOWNLOAD PROCEDURE**

1. **Turn the machine OFF.**
2. Insert the USB pen-drive into the (J10) port
3. **Turn the machine ON.**  
The LD5 orange led will blink advising that the software is downloading into the mother-board (refer to sketch on the side).  
As soon the download will be completed, the orange led LD5 will become OFF, and the green led LD6 starts to blink advising that the new software is running.
4. **Turn the machine OFF.**
5. Remove the USB pen drive from the slot of the card.
5. **Turn the machine ON to run for working**

**SLOT USB (J10)**

**N.B.:** The electronic card is always supplied without any software.  
In case of replacement of the mother-board, you got to download the software of the card following the above indicate procedure.

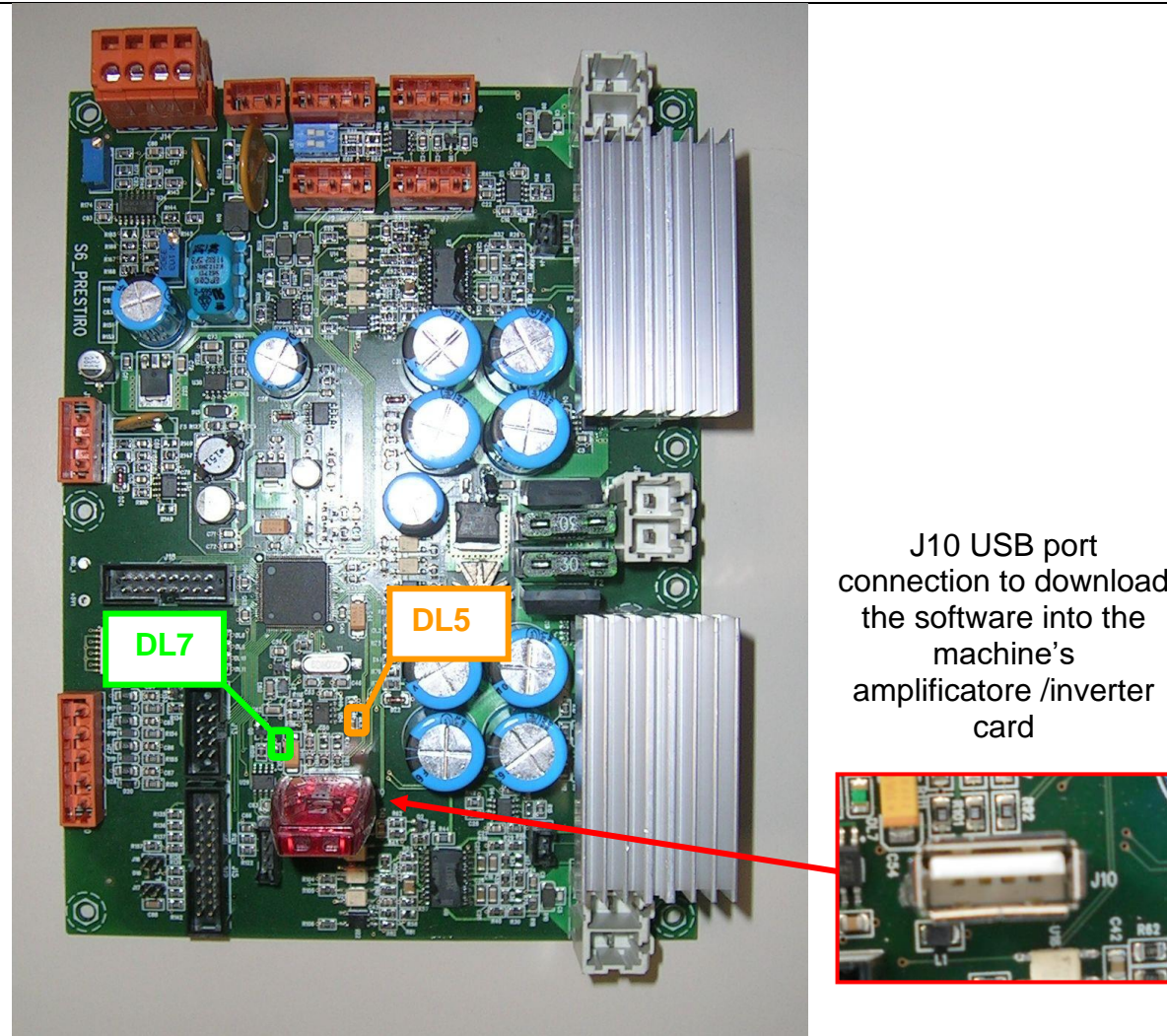
**AMPLIFIER CARD / PRE-STRETCH MOTOR INVERTER (U3) SOFTWARE DOWNLOAD PROCEDURE**

J10 USB port  
connection to download  
the software into the  
machine's  
amplificatore /inverter  
card

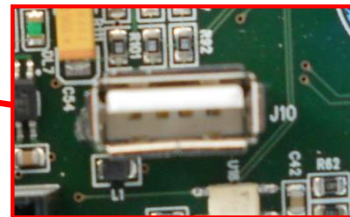

1. **Turn the machine OFF.**
2. Insert the USB pen-drive into the (J10) port
3. **Turn the machine ON.**  
The LD5 orange led will blink advising that the software is downloading into the mother-board (refer to sketch on the side).  
As soon the download will be completed, the orange led LD5 will become OFF, and the green led LD7 starts to blink advising that the new software is running.  
**Turn the machine OFF.**
4. Remove the USB pen drive from the slot of the card.
5. **Turn the machine ON to run for working**

**N.B.:** The electronic card is always supplied without any software.  
In case of replacement of the mother-board, you got to download the software of the card following the above indicate procedure.

**Very important:**

To complete the new software download and ensure that it will work fine, it is necessary to make the appropriate machine's software initialization following the procedure indicated on the side, step by step.  
In case that machine shows on the display the same message indicated on sketch 1, during the packing cycle, proceed anyway to initialize the software of the machine as indicated on sketches 2,3 & 4.

	<p>1</p> <p>Premere sull'icona "INIZIALIZZA" Press on the icon "INIZIALIZZA"</p>		<p>3</p> <p>Eeguire "DEFAULT PARAMETRI" e "DEFAULT RICETTE" Make "PARAMETER DEFAULT" &amp; "RECIPE DEFAULT"</p>
	<p>2</p> <p>ATTENZIONE !!!! VERIFICARE PARAMETRI CONFIGURAZIONE</p> <p>Premere sull'icona "RESET" Press on the icon "RESET"</p>	<p>4</p>	<p>Completare l'operazione di aggiornamento ed inizializzazione software impostando i parametri interni della macchina (P1 – P23) in accordo alla configurazione macchina. Complete the software installation and initialization setting the internal parameter of the machine (P1 – P23) according the machine's configuration.</p>

## MACHINE SETTINGS AND FUNCTIONS

(modifiable by password 6161 inserted only)

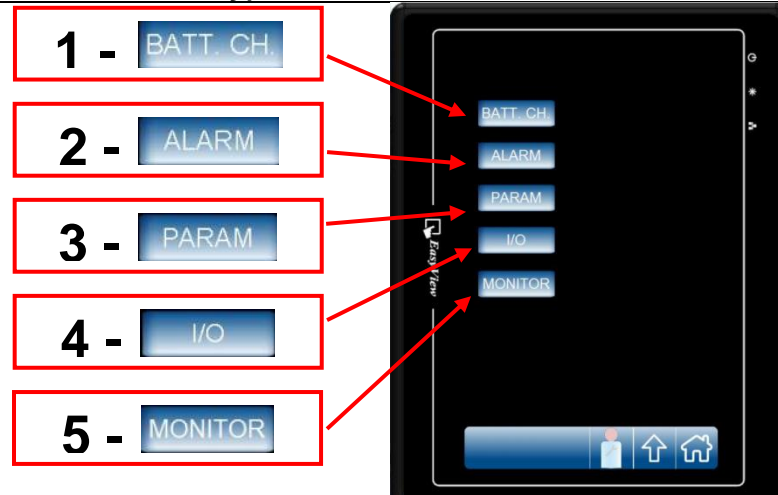

## BATTERY AND BATTERY CHARGER SETTING

The machine can be equipped with “acido” battery type or “gel” battery type. The battery charger is suitable to charge both type of batteries, but it is necessary set the “curve” of the charge based to the type and brand supplier following the next procedure:

1. Press the icon “settings” to access the SERVICE page (refer to above sketch).
2. Press the icon to access the page of battery and battery charger setting.
3. Press the icon to open the selection menu:



Access the drop down menus to select the type of battery



Select from the menu the battery fitted on the machine to determine the charge curve of the battery charger

4. Upon selection made press on the icon to confirm
5. Close the window pressing the icon

The charge “curve” is displayed by the parameter “**Curve**”.

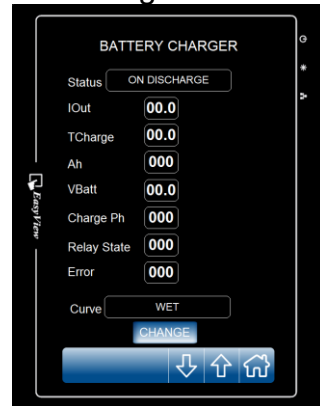
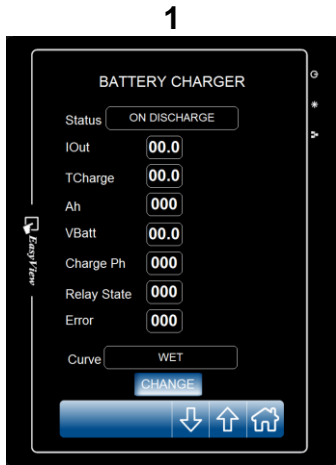

Status = working status  
Iout = out-feed battery voltage  
Tcharge = charge time  
Ah = amper/hour charged  
Vbatt = battery voltage  
Charge Ph = re-charge cycle running  
Relay state = relay status into battery charger  
Error = error code

### Current supplied by battery charger check during charge phase

Connecting the battery charger to the source, during the first minutes the supplied current from battery charger will be 11A ±0,5.

Then, checking the parameter Iout = 11A ±0,5. to check the appropriate function of the battery charger.

Press the icon  to access the page showing the report of the last 5 charges made.

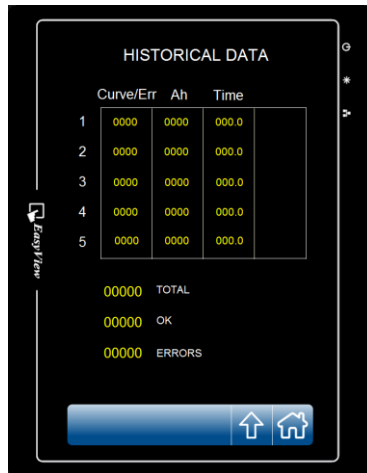

	Curve/Err	Ah	Time
1	0000	0000	000.0
2	0000	0000	000.0
3	0000	0000	000.0
4	0000	0000	000.0
5	0000	0000	000.0

00000 TOTAL  
00000 OK  
00000 ERRORS

**CurveErr** = Error code (see table below)

**Ah** = Total current charge

**Time** = Total charge time

**TOTAL** = Total number of charges made

**OK** = Number of charges done with positive result





**ERRORS** = Number of charges carried out with negative results

2



## TROUBLESHOOTING THROUGH ALARM HISTORY

It is possible to access the alarm history section to check the technical inconvenience had by machine.

1. Press the icona “settings”  to access the SERVICE page (refer to above sketch).
2. Press the icon  to access the page of the alarm history where it is possible to copy the history alarm list into a USB pen drive pressing the icon “”, or it is possible to delete the list by pressing the icon “”

3

## INTERNAL MACHINE'S PARAMETER AND LOAD-CELL (Extensometer) SETTING

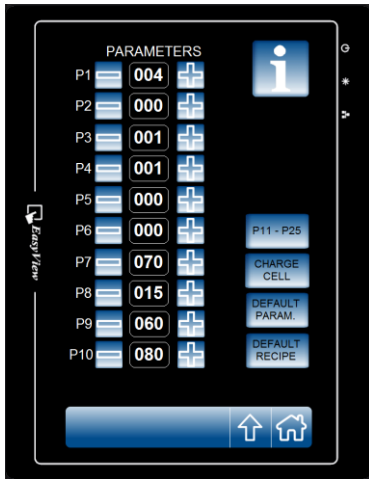

Pressing this icon, it is possible to open the curtain menu of the internal parameter of the machine with explanation of the values set.

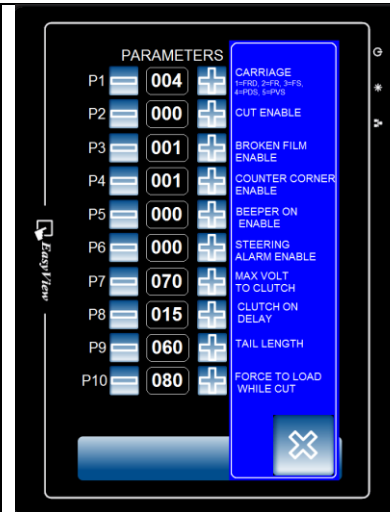

P11 - P25

Pressing this icon, it is possible to access to second page of the internal parameter.  
Pressing the icon it is possible to open the curtain menu with related explanations.

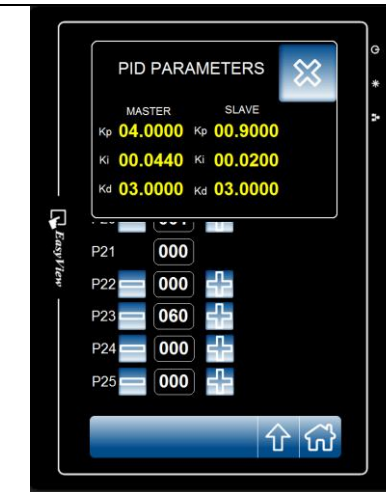
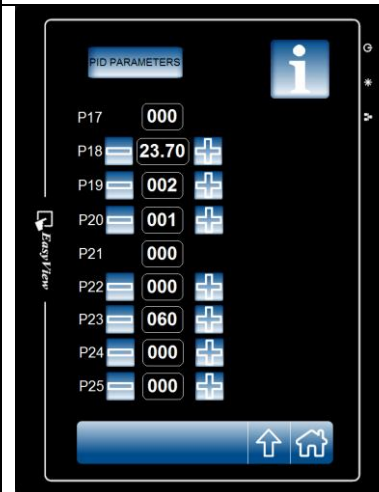



Parameter	Range setting values	Default values	Carriage type					Internal parameter setting description
			Carriage FRD	Carriage FR	Carriage FS	Carriage PDS	Carriage PVS	
P1	1 – 5	1	1	2	3	4	5	Film carriage type selection
P2	0 – 1	0						Enable cut film device
P3	0 – 1	0	Opz.	Opz.	Opz.	1	1	Enable break/cut film alarm
P4	0 – 1	1	1	1	1	1	1	Enable of counter-corner alarm (E61)
P5	0 - 1	0	0	0	0	0	0	Enable for acoustic signal during whole packing cycle.
P6	0 – 1	0						Enable of steering alarm (NOT ACTIVATED YET)
P7	0 – 100	70		X	X	X	X	Maximum voltage (V max.) to carriage friction for carriages FR/FS/PDS (film stretch / pre-stretch)
P8	0 – 50	15			X	X	X	Delay for brake pre-stretch connection upon machine's start (sec.)
P9	0 – 100	60						Tail length film upon cutting
P10	0 – 100	30						Film stretch during cutting
P17	0 – 1	0						<b>FOR ROBOPAC USE ONLY</b>
P18	23,3 - 23,8	23,7	(*)	(*)	(*)	(*)	(*)	Minimum battery threshold setting
P19	0 – 3	2						Maximum pre-stretch for PDS - <b>(0=150 / 1=200 / 2=250 / 3=300)</b>
P20	0 – 1	1						Enable modbus connection battery for battery charger
P21	0 – 1	0						<b>FOR ROBOPAC USE ONLY</b>
P22	0 – 1	0						Enable display for North Armerica measures (USA)
P23	30 – 720	60						Power-save time setting (machine shutdown)
P24	0 – 100	20						Down-ward distance spool carriage for top sheet cycle
P25	0 – 1	0						Enabling auto headlight flashing

( \* ) = set this value to 23,5 for battery Pb acid type, and set it to 23,7 for gel battery type

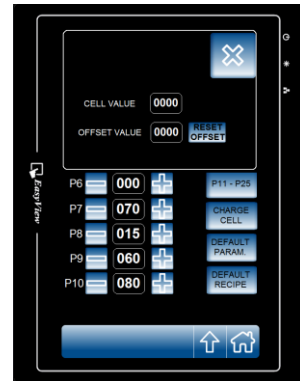
## LOAD CELL CALIBRATION



Pressing the icon  it is possible to access to the window which shows the setting of the load-cell (extensionmeter) to check the appropriate working and setting (display).

Keep pressed the icon  till the displayed value will keep a stable value, it is possible to make the “tuning” of the zero of the load-cell (extensionmeter), pressing the icon .

The appropriate setting must display a value of  $330 \pm 30$ .

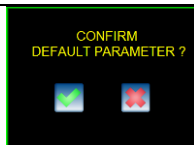

Pressing this icon, it will be possible to set the machine’s internal parameters to default values (producer setting)

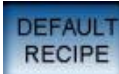

Pressing this icon, it will be possible to set the machine’s packing cycles parameter (recipe) to default values (producer setting).



**PID parameters (PRE-STRETCH MANAGE)**

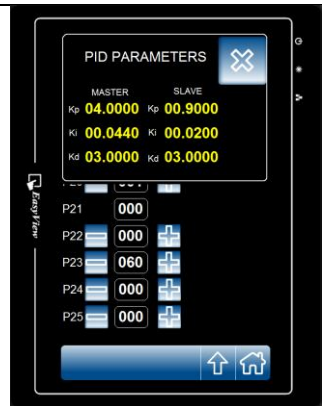

The appropriate setting of the PID are indicated in the table here below:

	Carrello PDS		Carrello PVS	
	MASTER	SLAVE	MASTER	SLAVE
<b>Kp</b>	04.0000	indifferente	04.0000	00.9000
<b>Ki</b>	00.0440	indifferente	00.0440	00.0020
<b>Kd</b>	03.0000	indifferente	03.0000	03.0000

Before change the PID values we recommend you to call ROBOPAC's after sales service.

4

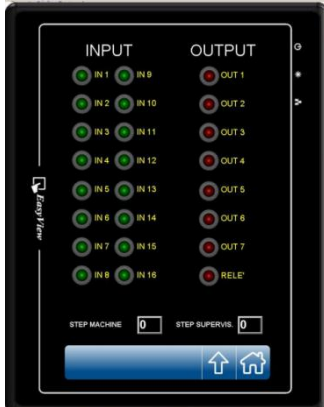

**TROUBLESHOOTING THROUGH INPUTS WORKING DISPLAY**

This page allow to check if the instruments (sensors and mechanical switches equipped on the machine) are properly working checking the inputs.

**I / O compararion table**

inputs		Outputs	
IN1	DL8	OUT1	DL25
IN2	DL9	OUT1	DL26
IN3	DL10	OUT3	DL27
IN4	DL11	OUT4	DL28
IN5	DL12	OUT5	DL29
IN6	DL13	OUT6	DL30
IN8	DL15	OUT7	DL31
IN9	DL16	RELAY	K1
IN10	DL17		
IN11	DL18		
IN12	DL19		
1N13	DL20		
IN16	DL23		

## LAYOUT MOTHER-BOARD AND I/O DESCRIPTION

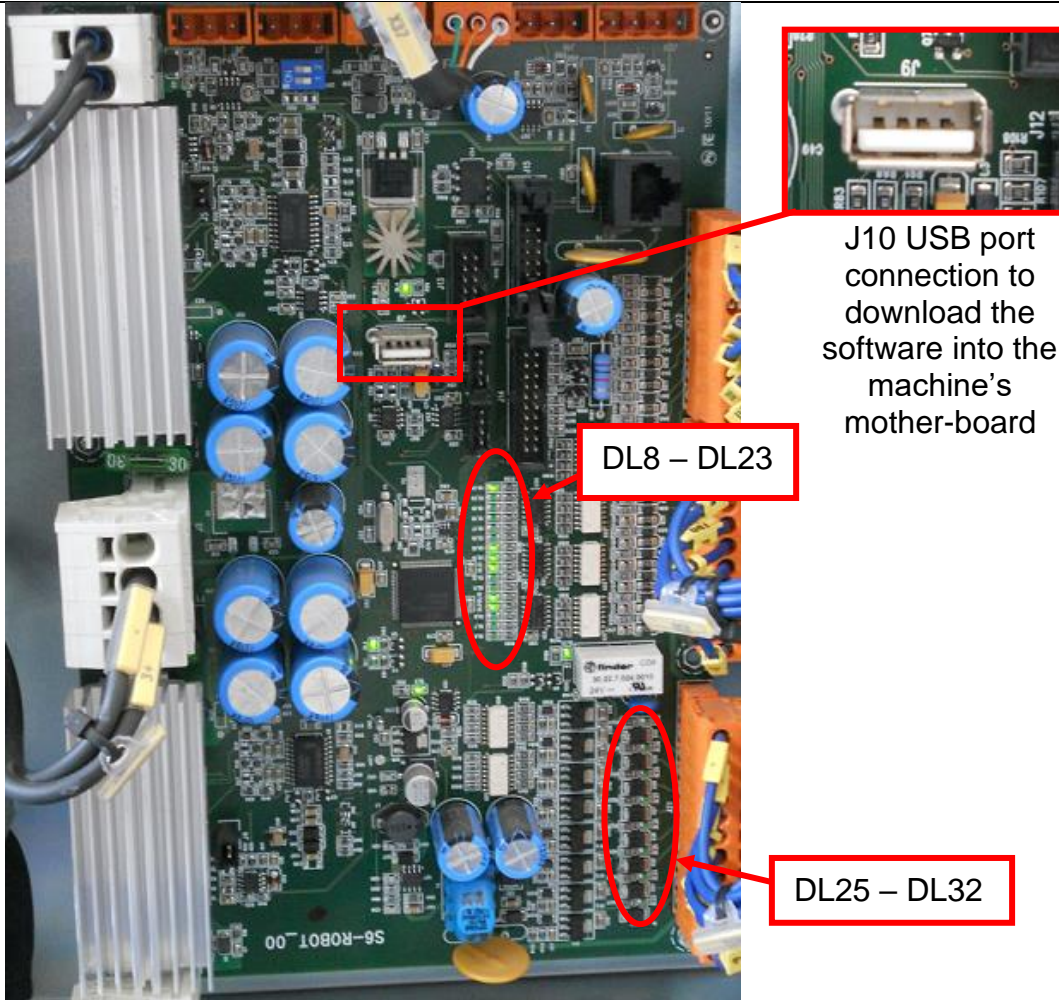

Led	Input / output description	Contact status	LED status on start
<b>Inputs</b>			
DL8	Emergency	N.O.	OFF
DL9	Start	N.O.	OFF
DL10	Reset	N.O.	OFF
DL11	Top limit switch	N.C.	ON
DL12	Bottom limit switch	N.C.	ON
DL13	Photocell detection product	N.O.	ON
DL14	--		
DL15	Counter corners sensor	N.O.	OFF
DL16	Emergency chain	N.O.	ON
DL17	Bumper emergency	N.C.	ON
DL18	Manual forward	N.O.	OFF
DL19	Manual backward	N.O.	OFF
DL20	Film break (carriages FRD-FR-FS) or Film unwind push button(PVS carriage)	N.O.	OFF
DL21	--		
DL22	--		
DL23	UP/DOWN carriage motor sensor (encoder)	N.O.	OFF
<b>Output</b>			
DL25	Power save function		
DL26	Traction brake		
DL27	Film cut		
DL28	Beeper		
DL29	Blinker		
DL32	Brake		

## TROUBLE-SHOOTING

In this section are available all notions related to machine's maintenance and trouble-shooting on which can be get access distributor and Robopac's service engineers .

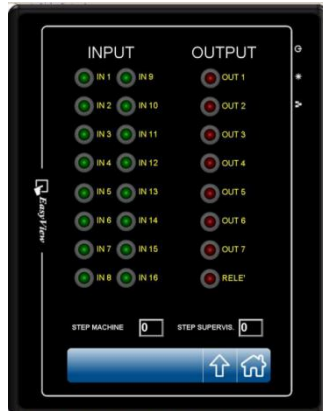
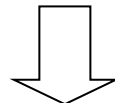
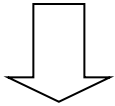

### TROUBLESHOOTING THROUGH OUTPUTS CHECKS

The machine is equipped of a particular function that allow you to manually activate some outputs to simulate their appropriate working or the appropriate working of the instruments installed on the machine (sensors, mechanical switches, etc).

Each output can be activated pressing the related red button

I / O compararison table			
inputs		Outputs	
IN1	DL8	OUT1	DL25
IN2	DL9	OUT1	DL26
IN3	DL10	OUT3	DL27
IN4	DL11	OUT4	DL28
IN5	DL12	OUT5	DL29
IN6	DL13	OUT6	DL30
IN8	DL15	OUT7	DL31
IN9	DL16	RELAY	K1
IN10	DL17		
IN11	DL18		
IN12	DL19		
IN13	DL20		
IN16	DL23		

5

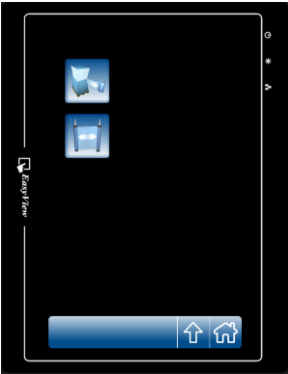

## GRAPHICAL DISPLAY OF STRETCH AND PRE-STRETCH VALUES

Using this page, it is possible to visualize in a graphical way, the minimum, maximum and medium values of film stretch and pre-stretch during the packing cycle.



**STRETCH**



**PRE-STETCH**

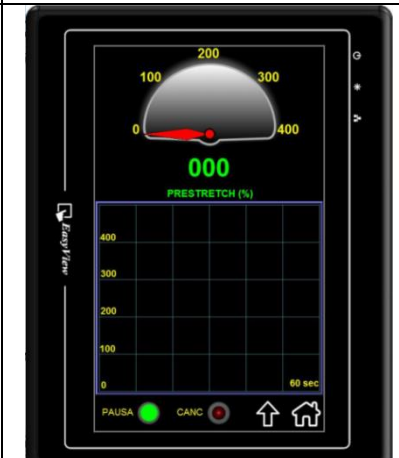
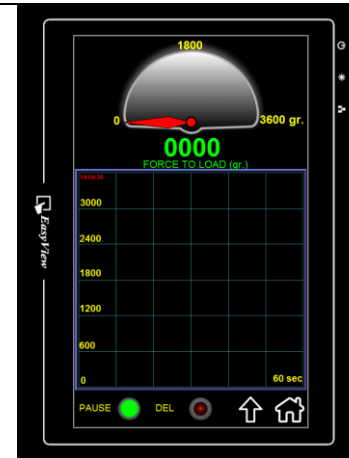

When the related led to "PAUSA / PAUSE" is ON and green, the software of the machine doesn't display the values of film stretch and pre-stretch. Pressing on the green led, the software start to display the values of film stretch and pre-stretch.

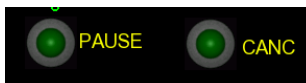

Pressing on the red led "CANC / ERASE" it is possible to erase a previous display of the values to start a new display of film stretch and pre-stretch

## HIDEN FUNCTIONS

In this section are available all notions related to machine's hidden functions which can be get access distributor and Robopac's service engineers



In questa pagina è possibile attivare un ciclo di imballo, e premendo sull'icona **AUTOM** sarà possibile visionare I valori di velocità del carrello con I relative carichi applicati



Pressing on the icon "Robopac brand " it is possible to access to the internal section which allow to run the machine and check the consumption and several loadings in the same time.

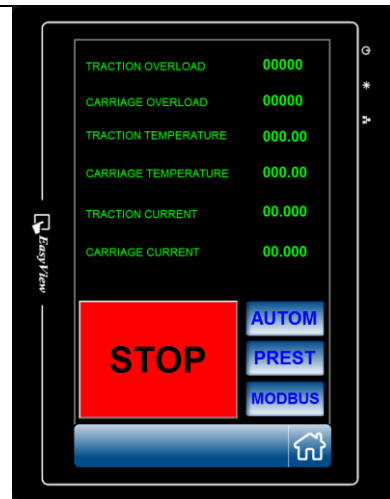

In this page is possible to run a packing cycle and pressing the icon **AUTOM** it will be possible to view the loads applied to check any trouble on the machine:

- Traction motor overload
- Up/down spool carriage motor overload
- Traction motor temperature
- Up/down spool carriage motor temperature
- Traction motor current
- Up/down spool carriage motor current

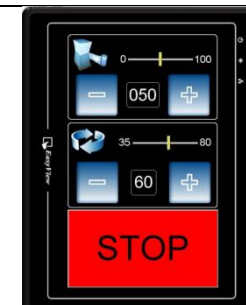

This page allows to set the value of the packing cycle to evaluate the working conditions of the machine with applied loads.

Press this icon to STOP the packing cycle test.



Pressing on the icon  it is possible to access to the page related to the checking of the the values of the pre-stretch (load-cell and amplifier card) and motor pre-stretch (inverter).

<b>CHARGE CELL</b>	Load-cell (extensometer) value	Va
<b>PVM</b>	Inverter running value (fast roll motor & slow roll motor for PVS carriage)	Va (n P'
<b>TEMPER</b>	Rotation pre-stretch roll motor temperature (fast roll motor & slow roll motor for PVS carriage)	Te (n P'
<b>I_OUT</b>	Current output amplifier/inverter card (fast roll motor & slow roll motor for PVS carriage)	C (n P'
<b>DRIVE STATE</b>	Drive Status (fast roll motor & slow roll motor for PVS carriage)	St (n P'
<b>DRIVE ALARM</b>	Drive alarm (fast roll motor & slow roll motor for PVS carriage)	Al (n P'
<b>RPM</b>	Rubber rolls speed (fast & slow roll)	Va (r
<b>PRESTRECH (%)</b>	Real pre-stretch value (speed ratio between fast and slow roll).	Pr (r
<b>PREST STATE</b>	Pre-stretch status (STOP / RUN)	St (S

Press this icon  to STOP the packing cycle test.



## - ROBOPAC USE ONLY – INFORMATION RELATED TO SOFTWARE PACK

In this page, it is possible to run a test packing cycle, and pressing on the icon **MODBUS** it will be possible to view the communication data between PLC and touch-panel of the machine (software pack communication):

<b>TOT MESS</b>	Total messages transmitted
<b>MESS. OK</b>	Messages successfully transmitted
<b>ERR. CRC</b>	Csum error
<b>ERR. TIMEOUT</b>	Timeout error
<b>ERR. FUNCTION</b>	Function error (it describes the type of error)
<b>ERR. SLAVE</b>	Error came from amplifier/inverter card for pre-stretch.

Press this icon to STOP the packing cycle test.

## BATTERY CHARGER SPECIFICATIONS

The battery charger equipped on the machine, got a diagnostic system through LEDs indications, to advise working status and fault alarm conditions.

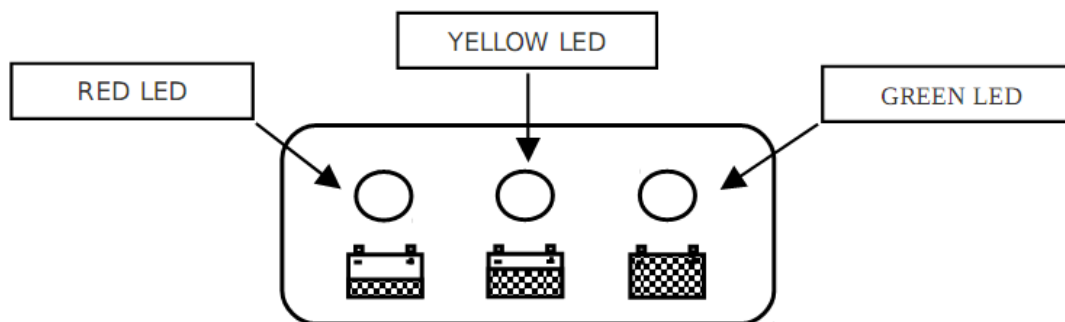

SIGNAL	MEANING	Error code	SPE code	Description
Red Led ON	Normal first charge phase	0	---	No error
Yellow Led ON	Normal second charge phase	1	E01	Max voltage
Green Led ON	End of the charge or maintaining phase	2	E02	Thermal Cut Off
	<b>ABNORMAL</b>	3	E03	Time Phase Overflow
Yellow Led BLINKING	Wrong battery, or not connected or out-feed shortcut	4	E03_1	Phase 1 Overflow
Red Led BLINKING	Overtime safety timer or internal shortcut	5	E03_2	Sulphation (Phase 2 Overflow)
	<b>STARTING TEST</b>	6	EDV	Dv/dt Error
Green Led DOUBLE BLINKING	Battery charger set to charge gel battery or AGM battery	7	EDI	Di/dt Error
Red Led DOUBLE BLINKING	Battery charger set to charge gel battery or Pb-acid battery	8	Srt	Internal Short Circuit
		9	Sct	Security timer
		10	Openmos	Broken Mofset (Opening)
		11	OPC	Connect Battery (Open circuit)
		12	Power module fault	Module Error (ex. Broken Module 1)
		----	----	----
		240	0xF0	Polarity inversion / no Battery
		241	0xF1	Stop Charging
		255	0xFF	Error (Generic)

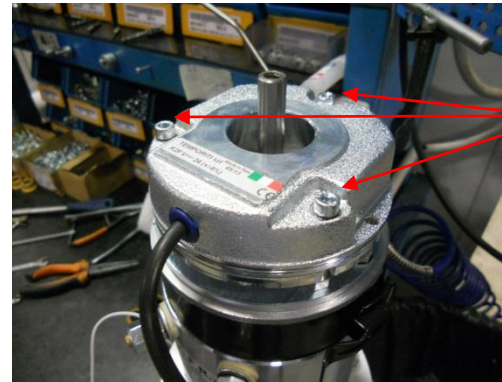

**TRACTION MOTOR BRAKE SETTING NOTIONS**

Unlock these three screws a little bit to be able to move the three adjusting screws (in the bottom).  
After adjusting relock these three screws.

This is the distance, that must be overdone by the electromagnetic



Using a spacer made of 0,2 – 0,3 mm thickness, adjust the three bottom screws being sure to uniformly adjust them in the appropriate way to have a constant gap all around the diameter of the magnetic brake.

## PRODUCT HEIGHT DETECTION PHOTOCELL CALIBRATION

### Standard photocell (for clear products)

Adjust the photocell sensitivity trimmer to load centre



### Dark product photocell (Datalogic model)

#### Suppression distance setting

##### 1. Object detection

Position object to detect in front of the sensor at the distance required.  
Turn distance adjustment trimmer (ADJ) to minimum: yellow LED OFF and green LED ON.



Rotate trimmer in a clockwise direction until the yellow LED and green LED turn ON: Object detection condition (A status of position indicator)



A

##### 2. Background suppression

Remove object and ensure that the background is in front of the sensor: yellow LED OFF and green LED ON.



Rotate trimmer in a clockwise direction until the yellow LED and green LED turn ON: background detection condition (B status of position indicator).



B

The trimmer reaches maximum level with yellow LED OFF if the background is outside the operating range.

Rotate trimmer in an anticlockwise direction until yellow LED turns OFF and green LED ON: condition where background is outside operating range (C status of position indicator).



C

##### 3. Setting and control

Rotate trimmer in an anticlockwise direction until the indicator reaches an intermediate point between position A and C.



If position A and C are close to each other, leave trimmer on position C. The sensor is now ready to function correctly and in stable conditions:



DETECTION DIAGRAM

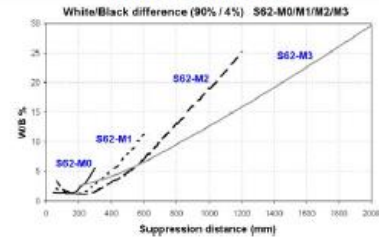

## Dark product photocell (Sunx model)

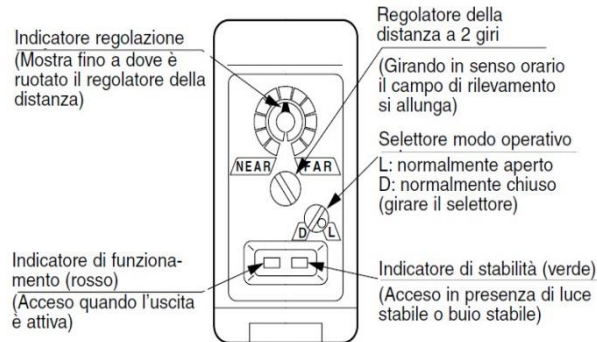

Set the selector "operation mode" to "L"  
(turn the selector clock-wise direction till the end).

### Sensitivity setting for dark product photocell

Turn completely the selector counter clock-wise direction in case of minimum distance (about 0.2mm).

### Distance selector

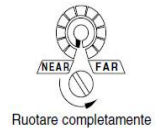

Locate the object to detect from the photocell (pallet centre) and turn the selector clock-wise direction till "A" to set the photocell in "light" condition (output active)

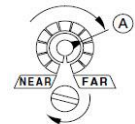

Remove the a.m. object. Turn the selector in clock-wise direction till switch again the photocell to "light" condition. When it become on, turn again the selector to switch to "dark" to "B" (if absence of the object to detect the photocell do not switch to "light" condition ON, the "B" point must be considered like maximum point of the setting range).

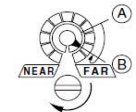

Set the selector to half range (middle between point "A" and point "B" that should be the best point to detect the object).

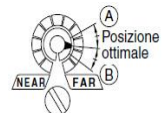

 <b>Norm. Tecn.</b> <b>60.2.49_05</b>	<b>TECHNICAL DOCUMENTATION</b> <b>- ROBOT S6 (Touch Screen Weintek Version) -</b>	<b>Date:</b> <b>July 2018</b>	<b>Rev.06</b>
	<b>ENGLISH</b>	<b>Pag. 74 / 86</b>	

## **POWER VOLTAGE TEST FOR SPOOL CARRIAGE CLUTCH / BRAKE**

<b>FS-PDS</b> <b>Carriages:</b>	Setting the film pre-stretch setting icon to maximum value, turn ON the machine and measure the voltage to the connections on the brake of the spool carriage. The measured value must be 15 Volt $\pm 0,5$ Volt.
<b>FR Carriage:</b>	Setting the film stretch setting icon to maximum value, turn ON the machine and measure the voltage to the connections on the brake of the spool carriage. The measured value must be 7 Volt $\pm 0,5$ Volt.

**ALARM LIST AND TROUBLE-SHOOTING**

Alarm Code	Alarm description	Troubleshooting	Cause of the fault	Solution
 (E 01)	Emergency push button pressed			Rotate and pull the emergency push button, then, press RESET
		Check the electric contact of the emergency push button SB1	The electric contact is defective	Replace the electric contact of the emergency push button SB1
		Check that input #2 (DL8) on mother-board works fine.	Input damaged on mother-board	Replace mother-board.



<b>E 10</b>	Bumper alarm				Press RESET button to run the machine.
			Check the electric contact on the mechanical switches SQ10 & SQ11 of the bumper	The electric contacts of the mechanical switches are defective	Replace the mechanical switches.
			Check that input #2 (DL17) on plc-card works fine.	Input damaged on mother-board	Replace mother-board.
<b>TRACTION DRIVER ALARM (E30)</b> DRIVER ###.##	Traction drive motor alarm  - TRACTION DRIVER OVERTEMP - TRACTION DRIVER SHORT CIRCUIT - TRACTION DRIVER UNDERVOLT - TRACTION HEAT SINK OVERTEMP - TRACTION CURRENT LIMIT		Disconnect motor from mother-board and run a cycle	The arlam message disappear.  The alarm message persists	Replace traction motor.  Replace mother-board
			Check the conditions of the brake connected to the traction motor	Defect on the brake.	Replace brake
			Check the gearbox connected to the traction motor	Defect on the gearbox.	Replace gearbox

	Up / down spool carriage drive motor alarm	- UP/DOWN CARRIAGE MOTOR DRIVER OVERTEMP - UP/DOWN CARRIAGE MOTOR DRIVER SHORT CIRCUIT	Disconnect motor from mother-board and run a cycle	If the error message no longer appears, it is a possible carriage motor failure.	Replace up/down carriage motor.
		- UP/DOWN CARRIAGE MOTOR DRIVER UNDERVOLT - UP/DOWN CARRIAGE MOTOR HEAT SINK OVERTEMP		If this message persists, it is a possible mother-board failure	Replace mother-board
		- UP/DOWN CARRIAGE MOTOR CURRENT LIMIT	Check the gearbox connected to the traction motor	Defect on the gearbox.	Replace gearbox

<div style="background-color: red; color: yellow; padding: 10px; border: 1px solid black;"> <p><b>FILM STRETCH DRIVER ALARM (E32)</b></p> </div>	<p>Film stretch motor alarm</p>	<ul style="list-style-type: none"> <li>- FILM STRETCH MOTOR DRIVER OVERTEMP</li> <li>- FILM STRETCH MOTOR DRIVER SHORT CIRCUIT</li> <li>- FILM STRETCH MOTOR DRIVER UNDERVOLT</li> <li>- FILM STRETCH MOTOR HEAT SINK OVERTEMP</li> <li>- FILM STRETCH MOTOR CURRENT LIMIT</li> </ul>	<p>Disconnect film stretch motor from inverter drive card and run a cycle.</p>	<p>If the error message no longer appears, it is a possible film stretch motor failure.</p>	<p>Replace film stretch motor.</p>
		<p>If this message persists, it is a possible failure of the film stretch motor inverter card.</p>		<p>Replace film stretch inverter card</p>	
<div style="background-color: red; color: yellow; padding: 10px; border: 1px solid black;"> <p><b>PRESTRETCH DRIVER ALARM (E33)</b></p> </div>	<p>Pre-stretch motor alarm</p>	<ul style="list-style-type: none"> <li>- PRE-STRETCH MOTOR DRIVER OVERTEMP</li> <li>- PRE-STRETCH MOTOR DRIVER SHORT CIRCUIT</li> <li>- PRE-STRETCH MOTOR DRIVER UNDERVOLT</li> <li>- PRE-STRETCH MOTOR HEAT SINK OVERTEMP</li> <li>- PRE-STRETCH MOTOR CURRENT LIMIT</li> </ul>	<p>Disconnect pre-stretch motor from inverter drive card and run a cycle.</p>	<p>If the error message no longer appears, it is a possible pre-stretch motor failure.</p>	<p>Replace pre-stretch motor.</p>
		<p>If this message persists, it is a possible failure of the pre-stretch motor inverter card.</p>		<p>Replace pre-stretch inverter card</p>	

<p><b>TRACTION MOTOR OVERCURRENT (E 35)</b></p>	<p>Traction drive motor overcurrent alarm</p>	<p>Disconnect motor from mother-board and run a cycle</p>	<p>If the error message no longer appears, it is a possible fault in the traction motor.</p>	<p>Replace traction motor.</p>
			<p>If this message persists, it is a possible mother-board failure</p>	<p>Replace mother-board</p>
		<p>Check the conditions of the brake connected to the traction motor</p>	<p>Defect on the brake.</p>	<p>Replace the motor brake traction</p>
		<p>Check the gearbox connected to the traction motor</p>	<p>Defect on the gearbox.</p>	<p>Replace gearbox</p>
<p><b>CARRIAGE MOTOR OVERCURRENT (E 35)</b></p>	<p>Up / down spool carriage drive motor overcurrent alarm</p>	<p>Disconnect up/down carriage motor from mother-board and run a cycle</p>	<p>If the error message no longer appears, it is a possible fault in the up/down carriage motor.</p>	<p>Replace up/down carriage motor.</p>
			<p>If this message persists, it is a possible mother-board failure</p>	<p>Replace mother-board</p>
		<p>Check the gearbox connected to the carriage motor</p>	<p>Defect on the gearbox.</p>	<p>Replace gearbox</p>

	<p>Film broken/finished alarm (option)</p>			<p>Replace the film reel on the carriage or connect the film to the product and press STAR.</p>
		<p>On models equipped with FRD, FR and FS carriages, check the position of the inductive sensor compared to the related cam on the free roll.</p>	<p>Wrong sensors position</p>	<p>Adjust the inductive sensor in the appropriate position.</p>
		<p>Check that inductive sensor works properly</p>	<p>Defect to the inductive sensor or its wiring.</p>	<p>Replaced inductive sensor</p>
		<p>Check input #5 (DL20) on mother-board</p>	<p>Damage of mother-board</p>	<p>Replaced mother-board</p>
		<p>On models equipped of PDS &amp; PVS carriages, check that load-cell is working properly</p>	<p>Load-cell does not manage to send the appropriate signal to the amplifier card</p>	<p>Replace load-cell</p>
			<p>Load-cell works properly</p>	<p>Replace amplifier card</p>

<p style="text-align: center;"><b>COUNTER CORNER ALARM (E61)</b></p>	<p>Counter-corner sensor alarm</p> 	<p>Check that inductive sensor is properly positioned compared its cam</p>	<p>Wrong sensors position</p>	<p>Adjust the inductive sensor in the appropriate position.</p>
		<p>Check that inductive sensor works properly</p>	<p>Defect to the inductive sensor or its wiring.</p>	<p>Replaced inductive sensor</p>
		<p>Check input #9 (DL15) on mother-board</p>	<p>Damage of mother-board</p>	<p>Replaced mother-board</p>
<p style="text-align: center;"><b>ENCODER CARRIAGE ALARM (E62)</b></p>	<p>Up / down carriage motor encoder alarm</p> 	<p>Check that inductive sensor is properly positioned compared its cam</p>	<p>Wrong sensors position</p>	<p>Adjust the inductive sensor in the appropriate position.</p>
		<p>Check that inductive sensor works properly</p>	<p>Defect to the inductive sensor or its wiring.</p>	<p>Replaced inductive sensor</p>
		<p>Check input #8 (DL23) on mother-board.</p>	<p>Damage of mother-board</p>	<p>Replaced mother-board</p>

<p><b>E80</b></p>	<p>Battery charger alarm</p>		<p>Battery charger device fault</p>	<p>Refer to battery charger device's troubleshooting on above pages (paragraph #14).</p>
<p><b>MODBUS H.M.I. ALARM (E81)</b></p>	<p>Communication alarm between touch panel and mother-board</p>	<p>Check cable which connect touch panel to mother-board</p>	<p>Defect of the cable</p>	<p>Replace cable</p>
<p><b>MODBUS PRESTRETCH ALARM (E82)</b></p>	<p>Communication alarm between mother-board and amplifier/inverter card</p>	<p>Check cable which connect mother-board to amplifier/inverter card</p>	<p>Defect of the cable</p>	<p>Replace cable</p>
		<p>Chek touch-panel and mother-board</p>	<p>Fault of connectors of the mother-board or touch panel</p>	<p>Replace mother-board or touch panel</p>
		<p>Chek mother-board and amplifier/inverter card</p>	<p>Fault of connectors of the mother-board or amplifier/inverter card</p>	<p>Replace mother-board or amplifier/inverter card</p>



Norm. Tecn.  
60.2.49\_05

**TECHNICAL DOCUMENTATION**  
**- ROBOT S6 (Touch Screen Weintek Version) -**

Date:  
July 2018

Rev.06

ENGLISH

Pag. 83 / 86

**E 90**

Battery discharged alarm

Battery on board of  
machine are discharged

Immediately plug the  
battery charger of the  
machine to the power  
source



Norm. Tecn.  
60.2.49\_05

**TECHNICAL DOCUMENTATION**  
**- ROBOT S6 (Touch Screen Weintek Version) -**

Date:  
July 2018

Rev.06

ENGLISH

Pag. 84 / 86

The machine doesn't pre-stretch the film properly	Check the run of the film into the rolls of the spool carriage and check the quality of the film.	Possible improper use of the machine.	Apply on the machine the correct film and run it properly into the rolls following the instructions.
	On machines equipped of FS or PDS, check the conditions of the clutch	The clutch is completely wear	Replace clutch
		The clutch receive the appropriate voltage (refer to above paragprh #16)	Replace clutch
		The clutch doesn't receive the appropriate voltage (refer to above paragprh #16)	Replace mother-board
	On machines equipped of PVS carriage, check the amplifier/inverter card	Defect of amplifier/inverter card	Replace amplifier/inverter card

The film breaks during packing or it is not properly applied to the product (too tight or too light).	Check the run of the film into the rolls of the spool carriage and check the quality of the film.	Possible improper use of the machine.	Apply on the machine the correct film and run it properly into the rolls following the instructions.
	Check that load-cell (extensiometer) isn't mechanically damaged or wrongly mounted	Check that load-cell (extensiometer) isn't properly fit or it is mechanically defected	Make sure of the appropriate installation of the load-cell (extensiometer). If the instrument is properly fit, replace it because it could be defected.
	Check that load-cell (extensiometer) isn't electrically defected	Electrical defect of the load-cell (extensiometer) for the film stretch sensitivity	Make the setting of the load-cell (extensiometer) following the instruction on above page 24. In case it will be not possible to get the appropriate setting, replace it because it could be defected.
	Check that the amplifier/inverter card for the signal of the load-cell (extensiomenter) isn't electrically defected	Defect of the amplifier/inverter card	Make the setting of the load-cell (extensiometer) following the instruction on above page 24. In case it will be not possible to get the appropriate setting, replace it because it could be defected.

## ROBOPAC SECTION

(this section is accessible by Robopac' service engineers only).



All the functions described in this paragraph related to "ROBOPAC SECTION" can be used by ROBOPACs SERVICE personnel, through a specific password which allow to access to all accounts levels.

In case of alarms on motors because of few cause, it is possible to get more information in the page of the touch-screen panel selecting the icon "Alarm History".



Accessing to the service section through the ROBOPAC's account, it is possible to view the alarm history to troubleshoot and solve the problems.



In the alarm list page, all the alarm message become memorized. The first alarm shown in the list matches with the last occurred.