

MASTERPLAT - MASTERPLAT TP FRD - PGS

serial n°

 USE AND MAINTENANCE MANUAL

"Translation of the original instructions"

**MACHINE WITH ROTATING PLATFORM FOR WINDING PLASTIC
STRETCH FILMS**

Instructions manual code 3709300785

English Edition 0/0615

EC DECLARATION OF CONFORMITY

(Annex IIA DIR. 2006/42/EC)

Robopac S.p.A.

Via Fabrizio da Montebello, 81 - 47892

Gualdicciolo Republic of San Marino

DECLARES THAT THE MACHINE

	
Robopac S.P.A. a Socio Unico Via Fabrizio da Montebello, 81 47892 - Gualdicciolo Repubblica San Marino www.aetnagroup.com	
	
MODELLO	
MODEL	
MATRICOLA	
SERIAL NUMBER	
DATA	
DATE OF MAN.	
ALIMENTAZIONE	
SUPPLY VOL.	V
FREQUENZA	Hz
FREQUENCY	
N. FASI	
PHASE	
ASSORBIMENTO	
ABSORPTION	A
POTENZA TOT.	
TOTAL POWER	KW
CONSUMO ARIA	
AIR CONSUMPTION	l/min.
PRESSIONE MAX	
MAX PRESSURE	bar
PESO	
WEIGHT	Kg

IS IN CONFORMITY WITH DIRECTIVES

European Parliament and Council Directive 2006/42/EC dated May 17, 2006

European Parliament and Council Directive 2004/108/EC dated December 15, 2004

European Parliament and Council Directive 2006/95/EC dated December 12, 2006

Reference to harmonised standards and relevant annexes, in applicable points:

EN ISO 12100:2010, EN 60204-1:2006/A1:2009, EN 415-5:2010, EN 415-6:2013, EN 415-10:2014.

THE INDIVIDUAL AUTHORISED TO DRAFT THE TECHNICAL BOOKLET IS

Mr. Pierangelo Laghi, R&D Manager

Via Fabrizio da Montebello, 81 - 47892 Gualdicciolo (RSM) – Republic of San Marino

Document date and place

Ing. Pierangelo Laghi

R&D Manager

San Marino,

Firma

SUMMARY

1	GENERAL INFORMATION		
1.1.	PURPOSE OF THE MANUAL.....	3	
1.2.	MANUFACTURER AND MACHINE IDENTIFICATION.....	4	
1.3.	TERMS AND DEFINITIONS.....	5	
1.4.	MODES OF REQUESTING FOR ASSISTANCE.....	6	
1.5.	ATTACHED DOCUMENTATION	6	
2	SAFETY INFORMATION		
2.1.	GENERAL SAFETY PRECAUTIONS	7	
2.2.	SAFETY WARNINGS FOR HANDLING AND INSTALLATION	8	
2.3.	SAFETY WARNINGS FOR USE AND OPERATION	10	
2.4.	SAFETY WARNINGS RELATED TO INCORRECT USE.....	11	
2.5.	SAFETY WARNINGS ON RESIDUAL RISKS.....	13	
2.6.	SAFETY WARNINGS FOR REGULATIONS AND MAINTENANCE.....	16	
2.7.	INFORMATION AND SAFETY SIGNALS ...	17	
2.8.	SURROUNDING AREAS	18	
3	TECHNICAL INFORMATION		
3.1.	MACHINE GENERAL DESCRIPTION	19	
3.2.	DESCRIPTION OF THE OPERATION CYCLE	22	
3.3.	SAFETY DEVICE DESCRIPTIONS	23	
3.4.	DESCRIPTION OF THE ELECTRICAL DEVICES.....	24	
3.5.	DESCRIPTION OF ACCESSORIES ON REQUEST	25	
3.6.	TECHNICAL SPECIFICATIONS “MASTERPLAT FRD” AND “PGS”	27	
3.7.	COIL TECHNICAL SPECIFICATIONS “MASTERPLAT FRD” AND “PGS”	29	
3.8.	TECHNICAL SPECIFICATIONS “MASTERPLAT TP FRD” AND “PGS”	30	
3.9.	COIL TECHNICAL SPECIFICATIONS “MASTERPLAT TP FRD” AND “PGS”	32	
3.10.	NOISE LEVEL	33	
3.11.	INSTALLATION ENVIRONMENT CHARACTERISTICS	33	
4	INFORMATION ON HANDLING AND INSTALLATION OPERATIONS		
4.1.	RECOMMENDATIONS FOR HANDLING AND LOADING	34	
4.2.	PACKAGING AND UNPACKING.....	34	
4.3.	TRANSPORT AND HANDLING	35	
4.4.	INSTALLATION OF DISMOUNTED PARTS	35	
4.5.	FASTENING THE MACHINE	38	
4.6.	SETTING THE MACHINE INTO THE GROUND	38	
4.7.	RECOMMENDATIONS FOR CONNECTIONS	39	
4.8.	PNEUMATIC CONNECTIONS.....	39	
4.9.	ELECTRICAL CONNECTION	40	
5	INFORMATION ON ADJUSTMENTS		
5.1.	RECOMMENDATIONS FOR ADJUSTMENTS	41	
5.2.	ADJUSTING FILM “STRETCH”	41	
5.3.	REEL CARRIAGE LIFTING CHAIN ADJUSTMENT	44	
5.4.	TABLE ROTATION CHAIN ADJUSTMENT .	45	
5.5.	ADJUSTMENT OF TABLE GUIDE ROLLERS	45	
6	ABOUT THE USE		
6.1.	RECOMMENDATIONS FOR OPERATION AND USE	46	
6.2.	CONTROL DESCRIPTION	47	
6.3.	DESCRIPTION OF THE USER INTERFACE	48	
6.4.	MAIN MENU.....	49	
6.5.	SETTINGS MENU.....	51	
6.6.	MANUAL CYCLE MENU.....	52	
6.7.	SELF-LEARNING CYCLE MENU	53	
6.8.	MENU DISPLAYED DURING THE STRAPPING CYCLE (WITH THE EXCLUSION OF THE MANUAL CYCLE) ...	54	
6.9.	SIMPLIFIED DISPLAY MENU (EASY).....	55	
6.10.	VARIOUS	56	
6.11.	SWITCHING THE MACHINE ON AND OFF	57	
6.12.	CYCLE PARAMETER SETTING.....	57	
6.13.	WRAPPING CYCLES DESCRIPTION.....	58	
6.14.	STARTING AND STOPPING THE CYCLE .	60	
6.15.	CHANGE THE PRESSER HEIGHT	61	
6.16.	REEL LOADING.....	62	
7	MAINTENANCE INFORMATION		
7.1.	MAINTENANCE INSTRUCTIONS	63	
7.2.	MAINTENANCE PERIOD TABLE	64	
7.3.	LUBRICATION POINT DIAGRAM.....	65	
7.4.	LUBRICANTS TABLE	67	
7.5.	CONDENSATE DISCHARGE	68	
7.6.	CLEANING THE AIR FILTER.....	68	

SUMMARY

8 TROUBLESHOOTING

- 8.1. ALARM MESSAGES..... 69

9 SPARE PARTS REPLACEMENT INFORMATION

- 9.1. RECOMMENDATIONS FOR REPLACING PARTS..... 70
- 9.2. REPLACING ROTATING TABLE WHEELS 71
- 9.3. LIST OF THE RECOMMENDED SPARE PARTS..... 72
- 9.4. MACHINE DISPOSAL AND SCRAPING..... 72

10 ENCLOSED DOCUMENTATION

- 10.1. WARRANTY CONDITIONS 73
- 10.2. PRESSURE PLATEN PNEUMATIC DIAGRAM..... 74

GENERAL INFORMATION

1.1. PURPOSE OF THE MANUAL

- The manual is an integral part of the machine and is aimed to provide the operator the instructions for use in order to prevent and reduce the risks that arise from man-machine interface.

The information have been written by the manufacturer into Italian (the original language) in full compliance with the professional writing principles and the regulations in force.

The communication principles were chosen according to the target readers in order to ease the reading and understanding of the information.

The information may be translated into other languages to satisfy the legal and/or market requirements.

The manuals must be translated directly from the ORIGINAL INSTRUCTIONS, without modification.

Each translation (including that provided by the purchasing agent or by the company that introduces the machine into the country in question) must specify the message “Translation of the original instruction”.

- Keep this manual for the entire duration of its useful life in a well known and easy to access place, available for reference any time the need should arise.
- Refer to the table of contents and the analytical index in order to easily identify the subjects of interest.
- Some information may not correspond completely to the actual configuration of the machine delivered.
- Any additional information does not affect the readability of the text and the safety level.
- The manufacturer reserves the right to modify the contents of the manual without prior notice provided that the safety level is not altered.
- All information supplied by the recipients represents an important contribution to the improvement of the after-sales service that the manufacturer will offer to his/her customers.
- The symbols described below are used to highlight the most important information or specifications.

 **Danger
Warning**

The symbol indicates extremely hazardous situations which, if ignored, could seriously jeopardise personal health and safety.

 **Caution
Warning**

The symbol indicates that suitable actions must be adopted to prevent personal health and safety risks and avoid economic damages.

 **Important**

This symbol indicates critical technical and operating information that shall be observed.

GENERAL INFORMATION

1.2. MANUFACTURER AND MACHINE IDENTIFICATION

The illustrated identification plate is applied directly on the machine. It contains references and indispensable operating safety indications.

- A) Machine model.
- B) Machine's serial number.
- C) Year of manufacture.
- D) Power supply voltage.
- E) Power supply frequency.
- F) Power supply phases.
- G) Electrical power consumption.
- H) Total installed power.
- L) Air consumption.
- M) Max. air supply pressure.
- N) Machine weight.
- P) Manufacturer's name.

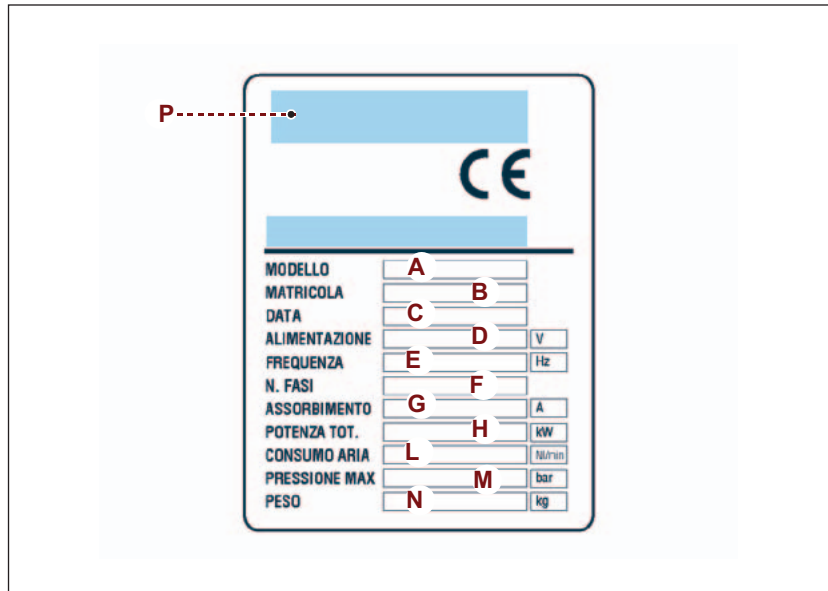

GENERAL INFORMATION

1.3. TERMS AND DEFINITIONS

Some recurring terms found within the manual are described in order to provide a more complete image of their meanings

- **Routine maintenance:**
Group of functions necessary to maintain suitable machine operations and efficiency. Normally the manufacturer, who defines the necessary skills and intervention procedures, plans these operations
- **Non-routine maintenance:**
The whole of the operations necessary to keep the operating and efficiency capacity of the machinery. These operations are not scheduled by the manufacturer and must be carried out by the maintenance technician
- **Operator:**
A person authorised and chosen from those who have the requirements, skills and information necessary for installation, use and ordinary maintenance of the machine
- **Maintenance technician:**
A person authorised and chosen among those who have the requirements, skills and information necessary to perform ordinary and extraordinary machine maintenance. He is expected, therefore, to possess precise information and skills with particular expertise in the field of intervention
- **Format Change:**
series of operations to carry out on the machine before starting to work with the machine with different characteristics respect to the previous ones
- **Training:**
training process aimed to transfer to the operator the knowledge, skills and behaviour required to operate the machine autonomously, properly and safely
- **Installer:**
technician chosen, among those that meet the requisites, and authorised by the manufacturer or by its representative, to install and test the machine or the system in question
- **Assistant:**
employee assigned to assist the production processes of the machine or system in question

GENERAL INFORMATION

1.4. MODES OF REQUESTING FOR ASSISTANCE

The distribution network ROBOPAC is at your service for any problem that requires technical support, to order spare parts, and for whatever new type of need that can help develop your business.

Report the data displayed on the ID plate, the estimated hours you have used the machine, and the type of flaw you have uncovered when requesting technical support.

Contact one of our authorized dealers at the listed address for all your needs.

ROBOPAC SPA
VIA FABRIZIO DA MONTEBELLO, 81
47892ACQUAVIVAGUALDICCILO, REPUBBLICA. MARINO (RSM)
Phone: 0549 (international ++378) 910511
Fax: 0549/908549 - 905946
<http://www.aetnagroup.com>

1.5. ATTACHED DOCUMENTATION

The machine is provided with the documentation listed below, in the absence of a different trade agreement.

- CE statement of conformity.
- Warranty conditions (included in this booklet).
- Instructions for unpacking and installation.
- Quick start guide.
- Wiring diagram and list of components.
- Pneumatic diagram and list of parts (included in this booklet).
- Manuals of installed commercial devices (if necessary for machine use).
- USB flash drive that contains the information listed.
 - Use and maintenance manual translated into various languages.
 - Spare parts catalogue.

SAFETY INFORMATION

2.1. GENERAL SAFETY PRECAUTIONS

- Carefully read the “Instructions for use” specified in the manual and those applied directly to the machine.
It is important to dedicate a little time to read the “Instructions for use” in order to minimise the risks and avoid unpleasant accidents.
- Before performing any operation, the operator must make sure that he/she understood the “Instructions for use”.
- Pay attention to the SAFETY WARNINGS, do not use the machine for UNSPECIFIED PURPOSES and assess the possible RESIDUAL RISKS.
- Caution is essential.

Safety is also in the hands of those who interface with the machine throughout its life span.

Sometimes, accidents can be caused by a “careless” use of the machine by the operator.

Usually it is too late to remember what should have been done when the accident has already happened.

- Preserve the readability of the information signs and observe the indications given.
The information signs may have different shapes and colours, indicating hazards, obligations, prohibitions and information.
- The manufacturer has designed the machine observing all the “good manufacturing regulations” and the standards in force.
The machine has been designed to be constructed and equipped with devices that ensure intrinsic safety.
Tampering with the safety devices and the removal of the same may create risks (even severe) for the operators.
- The personnel authorised to carry out any operation with the machine must have acknowledged experience in the specific field.
- **The manufacturer is not responsible for any damage to the product delivered in the package during the wrapping and stabilisation and the following operation phases.**

Non compliance with the instructions given may cause risks for safety and health of the persons and economic damages.

SAFETY INFORMATION

2.2. SAFETY WARNINGS FOR HANDLING AND INSTALLATION

- The personnel authorised to handle the machine (loading and unloading) must possess particular expertise in the field of intervention.
- Handle (load and unload) the machine according to the instructions affixed directly to the machine, to the package and those in the user manual.
- During handling use one or two assistants, if required. This operation may generate unpredictable risks.
In order to minimise the risks related to assistants' involvement, you must inform them priorly on the type of work and the behaviour to be used.
- The machine must be handled with the aid of specific means (crane, forklift etc.) by qualified personnel capable of observing the safety requirements.
- When using the lifting means, insert and/or fasten the devices (hooks, forks etc.) ONLY into the points provided on the package and/or the machine.
- Transport the machine suitable means of adequate capacity.
- Make sure the machine and its components are properly fastened to the transport mean.
Check the machine dimensions and affix proper signs if the machine overall dimensions exceed the values allowed by road regulations.
- The minimum and maximum temperature (during transport and/or storage) must fall within the range allowed in order to prevent damaging the electrical components.
- Install the machine ONLY in spaces free of explosion and /or fire risks.
- Avoid the spaces exposed to atmospheric and corrosive agents.
- Assess, prior to installation, if it is necessary to draw up a “safety plan” in order to protect the safety of the personnel involved.
- Provide proper safety conditions when operating at high altitudes areas that are dangerous and hard to access.
- Install the machine according to the minimum perimeter indicated by the manufacturer and the surrounding activities.
- Should the machine interface directly/indirectly with other machines or production lines, draw up the installation design of the machine. The design must include all the operating conditions in order to comply with the standards in force on safety at work place.
- Check that the installation space is properly ventilated in order to avoid air concentration unhealthy for the operators.
- Apply the most suitable solutions for reducing the noise levels and the acoustic pollution to minimum.
- Carry out the electrical connections professionally and in full compliance with the instructions provided by the manufacturer and the specific regulations in force.

The electrical connections must be carried out EXCLUSIVELY by operators with particular expertise in the field of intervention.

SAFETY INFORMATION

- The operator must test the machine and check, through a general test, that the machine can be commissioned without any risk for the operator.
- Dismantle all the packaging components in compliance with the standards in force in the country of installation.

Non compliance with the instructions given may cause risks for safety and health of the persons and economic damages.

SAFETY INFORMATION

2.3. SAFETY WARNINGS FOR USE AND OPERATION

- The operator must be trained and possess the proper knowledge required to carry out the specific tasks and must meet the conditions required for the safe use of the machine.
- When using the machine for the first time, the operator must read the manual and identify the controls and simulate some operations, especially the start-up and shutdown.
- The machinery has been designed and manufactured to satisfy all the operating conditions indicated by the manufacturer.

Use the machine ONLY with the original safety devices installed by the manufacturer.

DO NOT tamper with, remove or bypass the safety devices installed on the machine.

- DO NOT modify the constructive and functional characteristics of the machine.
- Do not use the machinery with the safety devices not properly installed and efficient.
- ALWAYS wear the individual safety devices indicated in the “Instructions for use” and provided by the standards in force regarding the safety at workplace.
- ALWAYS keep the surrounding areas in suitable conditions and free of obstacles in order to minimise the risks, especially near the control station.
- The machine must be used by one operator ONLY, that must be assigned and authorised by the employer.
- The involvement of one or more assistants when performing some operations or maintenance (ordinary) interventions may present unpredictable risks.
In order to minimise the risks related to assistants’ involvement, you must inform them priorily on the type of work and the behaviour to be used.
- Make sure that no foreign persons are present within the machine operating area during its production activity and maintenance.

Non compliance with the instructions given may cause risks for safety and health of the persons and economic damages.

SAFETY INFORMATION

2.4. SAFETY WARNINGS RELATED TO INCORRECT USE

Incorrect use that can be reasonably expected

- The predictable incorrect use consists of: “the use of the machine different from the indications given in the manual, that may stem from the easily predictable human behaviour”.

The machine must be used ONLY for wrapping and stabilising products with regular shape or with a shape that ensure a stable wrapping.

The packs that contain liquids or insubstantial materials must be suitable for the product and must be perfectly closed and tight in order to prevent any leaks of the content.

DO NOT wrap or palletize products in packaging (boxes, containers for liquids, etc...) with an irregular form or one that does NOT guarantee their stability.

- The machine must be used ONLY for the uses intended by the manufacturer.
- DO NOT allow the machine to be used by operators that are not properly trained, informed and unauthorised.
- Packages that contain liquid or inconsistent products must ensure that they do not leak.
- DO NOT wrap products that are loose, that have an irregular shape or that are not suitably collected, to prevent inadequate palletisation.
- Do not use the machine to wrap and stabilise living beings (animals and humans).
- DO NOT use the machine with wrapping material different from that provided by the manufacturer.
- Do not use the machine as a lifting device or as a rest surface for work activities (for example, a workbench).
- Do not over stretch or pre-stretch the film and do not wrap with an excessive number of bindings in order to prevent damaging the packages and products contained inside.
- DO NOT use or let the machine be used for purposes or in ways not provided by the manufacturer.
- DO NOT use or make use of machines with defective, deactivated and/or not perfectly installed safety devices.
- DO NOT continue to use the machine if malfunctions have been detected.
Stop the machine immediately and restart it only after the normal conditions of use have been restored.
- NEVER carry out an intervention with the machine enabled but ONLY after having stopped it properly, under safety conditions.
- NEVER use the machine without wearing the Personal Protective Devices indicated by the manufacturer and required by current workplace laws.
- NEVER use the machine if the scheduled maintenance interventions have not been carried out accordingly.

SAFETY INFORMATION

- DO NOT clean or wash the machine with aggressive products to avoid damaging the components.
- DO NOT replace the components with non-original spare parts or with different design and constructive features.
- DO NOT leave the machine unattended at the end of the work without shutting it down first in safety conditions.

Employer obligations

- The operator must be trained to acquire the skills required for the packaging machine or an equivalent machine.
Upon completion of training, make sure the operator has understood the contents in the use manual, especially the information regarding safety.
- The operator must possess the required training and meet the suitable conditions for carrying out the activities in safety conditions.
- The employer must inform the operator on the INCORRECT USES predictable and on the persistent Residual risks.
- The operator must be capable of reading and understanding the user manual and must easily identify the safety signs.
- Make sure the machine is ONLY used by adequately trained, documented and authorized operators.

The employer must draw up the documentation of the specific training carried out by the operators in order to exhibit it in case of litigation.

SAFETY INFORMATION

2.5. SAFETY WARNINGS ON RESIDUAL RISKS

When designing and building the machine, the manufacturer has paid particular attention to the RESIDUAL RISKS that may affect the safety and health of the operators.

The residual risks are: “all the risks that persists although all safety solutions have been applied and integrated during machine design”.

The list specifies the residual risks specific for this type of machine.

- **Danger of collision and slipping.**
Do not get onto machine parts during its operation.



- **Danger of collision and slipping**
do not come near machine parts during its operation.



- **Upper limb cutting hazard**
Do not place hands inside components in motion.

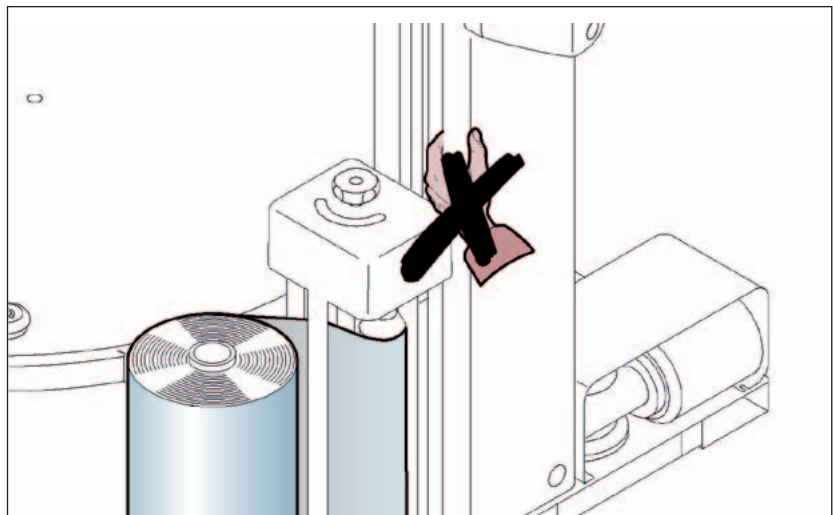

SAFETY INFORMATION

- **Body crushing hazard**
Do not linger in the machine operating area.

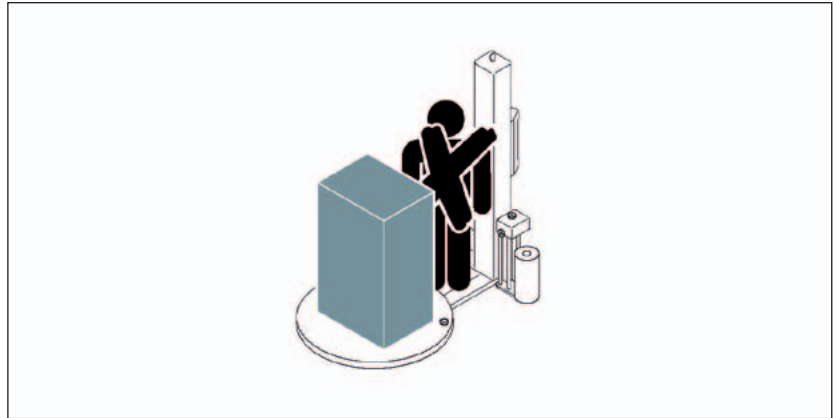

- **Body crushing hazard.**
Do not linger in the machine operating area.



- **Danger of arms crushing**
Do not place hands inside components in motion.

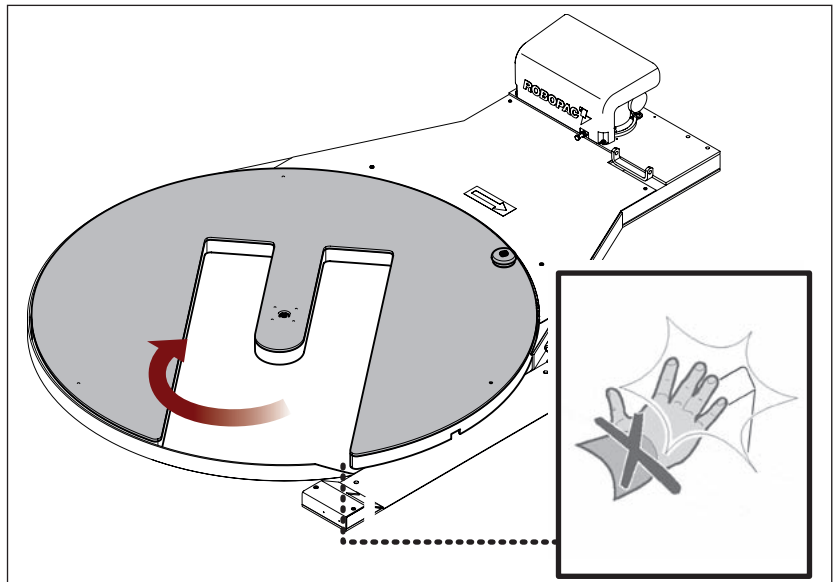

SAFETY INFORMATION

- **Danger of collision and slipping**
Do not draw close to or climb onto machine parts (i.e. the turntable) with the lifting device while the machine is running
- **Danger of projecting or falling objects**
Do not use the machine at a speed that is not appropriate for the product you need to wrap.

If the packages you need to wrap contain unstable or hazardous elements, you must adopt suitable safety precautions (i.e. perimeter guards) to prevent the risk of harming the physical wellbeing of personnel.



SAFETY INFORMATION

2.6. SAFETY WARNINGS FOR REGULATIONS AND MAINTENANCE

- Keep the machinery in maximum efficiency condition and perform all the scheduled maintenance operations provided for by the manufacturer.
Proper maintenance will provide the best performance, a longer life span and constant compliance with safety requirements.
- Enable all machine safety devices before performing any maintenance and regulation operations.
- Delimitate the work area complying with the safety conditions as provided by the standards on workplace safety in order to minimise the risks.
- The maintenance interventions in the areas that are not easily accessible or dangerous must be carried out after having ensured the necessary conditions.
- The personnel authorised to carry out the ordinary maintenance (regulations, replacements etc.) must possess the necessary technical and professional knowledge.
- DO NOT carry out interventions different from those indicated in the user manual without the written consent of the manufacturer.
- DO NOT use products that contain corrosive, toxic and inflammable substances.
- Wear the Individual Protection Devices provided by the laws on workplace safety and indicated in the “Instructions for use” and/or affixed to the machine.
- Replace the components ONLY with ORIGINAL PARE PARTS or with SIMILAR design and functional features.
- The use of similar but non-original spare parts may lead to improper repairs, altered performance and economic damage.
The components and/or safety devices shall be replaces ONLY with original spare parts to avoid altering the provided safety level.
- Use lubricants (oils or grease) recommended by the manufacturer or with similar chemical-physical features.
- Do not dump into the environment polluting liquids, worn parts and maintenance waste.
- Select the components according to the chemical and physical features of the material and carry out the differentiated waste disposal as per the standards in force.
- All the extraordinary maintenance interventions shall be carried out EXCLUSIVELY by authorised personnel with particular expertise in the field of intervention.

Non compliance with the instructions given may cause risks for safety and health of the persons and economic damages.

SAFETY INFORMATION

2.7. INFORMATION AND SAFETY SIGNALS

The figure indicates the position of the safety and information signs affixed to the machine.

For each sign is specified the relative description:

- A) Electrical hazard sign**
Do not access this area: risk of electrical shock or electrocution.
- B) Prohibition sign**
Do not climb onto the ramp with the forklift.
- C) Information sign**
Indicates the points for lifting with a hook device.
- D) Information sign**
indicates the lifting points with a fork device
- E) Information sign**
Indicates the direction in which the turntable rotates
- F) Prohibition sign**
Do not operate the component with your hands
- G) Hazard sign**
Hand crushing danger.

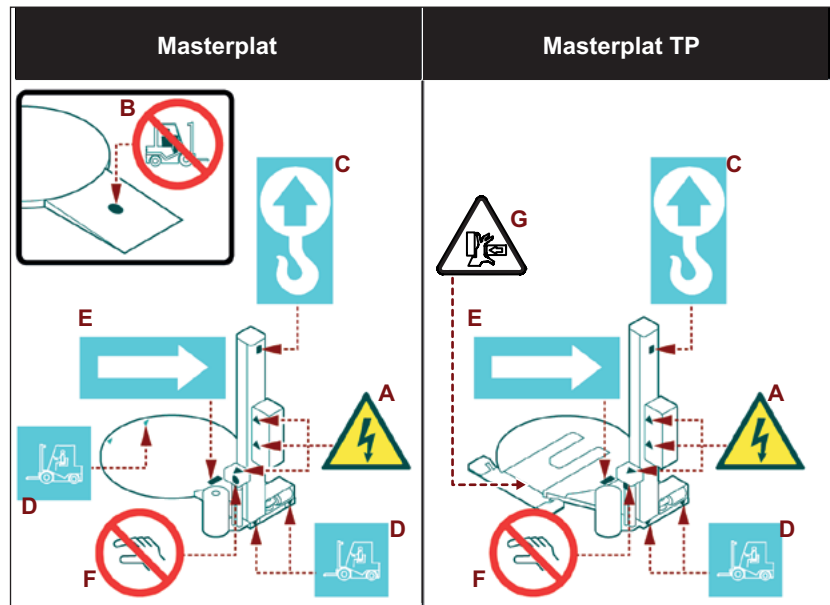

 Important

Check that the plates are clearly readable, and, if necessary, replace them with new ones that shall be positioned in the same places as previously.

SAFETY INFORMATION

2.8. SURROUNDING AREAS

The illustration depicts the perimeter work areas of the machine.

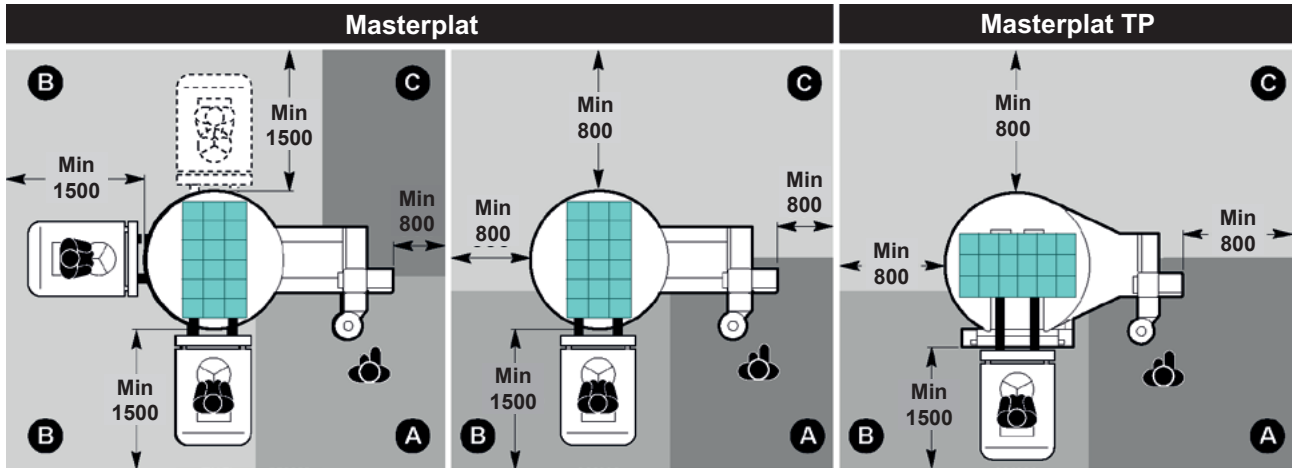

- A) Operator's working area
- B) Pallet loading/unloading area
- C) Surrounding area

TECHNICAL INFORMATION

3.1. MACHINE GENERAL DESCRIPTION

- This is a semi-automatic wrapping machine for wrapping and blocking palletized loads using stretchable plastic film.
- The machine must be EXCLUSIVELY used in order to wrap and stabilise products contained in packs (boxes, containers for liquids, etc.), having a regular shape or a shape that allows for stable palletising.
- The packs that contain liquids or insubstantial materials must be suitable for the product and must be perfectly closed and tight in order to prevent any leaks of the content.
- The machine is composed of a revolving table that turns the pallet, and a reel carriage that unwinds and stretches the film.
- It is equipped with a series of safety devices designed to avoid any harm befalling the operator or other persons who come into contact with the machine in any way. The machine is produced in a range of different models in order to suit market requirements.
- The loads are wrapped using reels of stretchable film which can be readily found on sale.
- This machine is normally installed in workshops or industrial environments protected from the atmospheric agents.

Use of this machine in explosive environments or when exposed to the elements is strictly forbidden.

- The user is responsible for the loading and unloading of the pallet, as well as for the insertion and cutting of the film.
- Only one operator is required for use.

TECHNICAL INFORMATION

The figure shows, as a reference only, the machine models and the tables show the data and the main specifications.

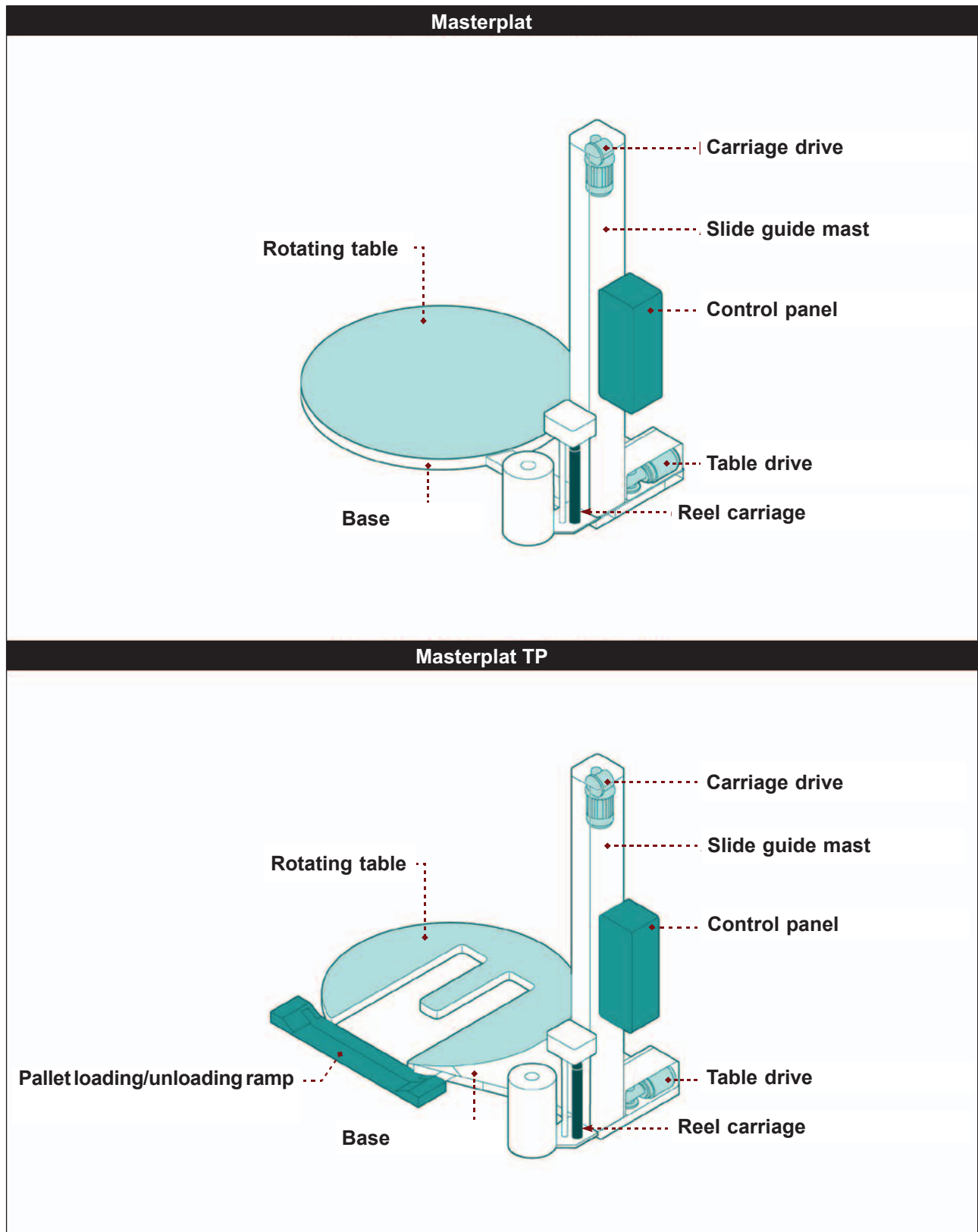

TECHNICAL INFORMATION

Table 3.1.:Type of machine

<i>Model</i>	<i>General Requirements</i>
Masterplat FRD	Masterplat with “ FRD ” or “ FRD for net ” type reel carriage.
Masterplat TP FRD	
Masterplat PGS	Masterplat with film carriage type “ PGS ”.
Masterplat TP PGS	
Masterplat FREEZER	Keeping the same features as the standard machine, this model can work at an ambient operating temperature of $-30 \div +40^{\circ}\text{C}$. The control panel is equipped with a heating system to protect the devices at low temperatures.
Masterplat INOX	Keeping the same features as the standard machine, this model is made of stainless steel for working in particular environments. It can be equipped upon request with the control panel with a heating system to protect the devices from low temperatures. In this case the machine can work at an ambient operating temperature of $-30 \div +40^{\circ}\text{C}$.

Table 3.2.: Roll-holder carriage specifications

<i>Type of reel holding carriage</i>	<i>General Requirements</i>
FRD	“ FRD ” and “ FRD for net ” type reel carriage; with friction roller, mechanical brake and manual film stretch adjustment.
PGS	“ PGS ”-type spool carriage; with driven pre-stretch rollers and electronic film tensioning. The pre-stretching is fixed (25%).

TECHNICAL INFORMATION

3.2. DESCRIPTION OF THE OPERATION CYCLE

- **Phase 1:**
The operator places the load on the rotating table and clasps the film in the blocking disk.
- **Phase 2:**
Once the cycle has started, the turntable starts turning, while the film carriage unwraps the film based on the preset parameters.
- **Phase 3:**
Once the wrapping has been completed, the machine manually cuts the film and stops.

The cycle ends and the machine is ready to start a new one.

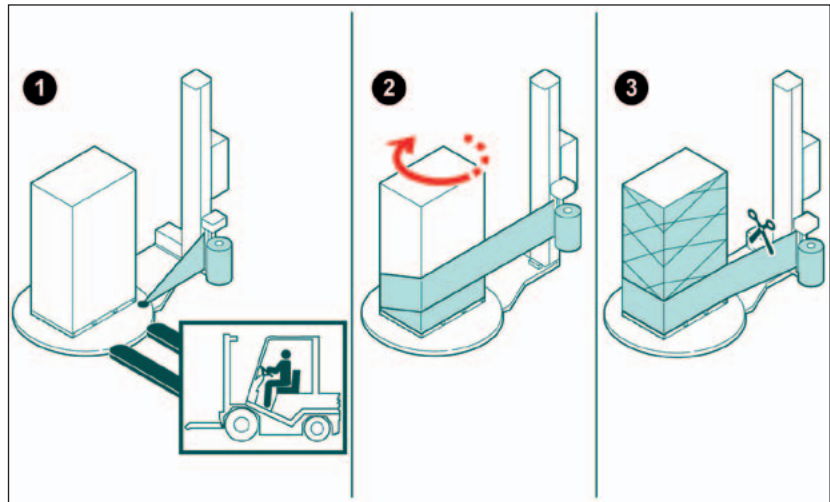

TECHNICAL INFORMATION

3.3. SAFETY DEVICE DESCRIPTIONS

The figure shows the positioning of the devices on board of the machine.

A) **Reel carriage base microswitch:** stops the descent when there are obstacles under the carriage:

B) **Mechanical device for blocking the reel carriage:** it stops the reel carriage falling in the event that the lifting rope breaks:

C) **Main switch:** to turn the electric supply on and off. It can be padlocked to prevent unauthorised personnel from starting the machine during adjustments and maintenance:

D) **Acoustic signal:** signals the start of the wrapping cycle:

E) **Fork entry photoelectric cell:** detects the presence of the forks on the pallet unloading/loading ramp, and stops the table rotating.

G) **Emergency button;** the machine stops immediately when this button is pressed in emergency situations. To reset, rotate the button in the direction indicated by the arrow.

! Danger - Warning

With the emergency button pressed, there might still be voltage at the terminals of the motor.

H) **Key selector:** used to reset the emergency of the spool carriage. If kept rotating it allows to lift the trolley through the manual controls on the user interface.

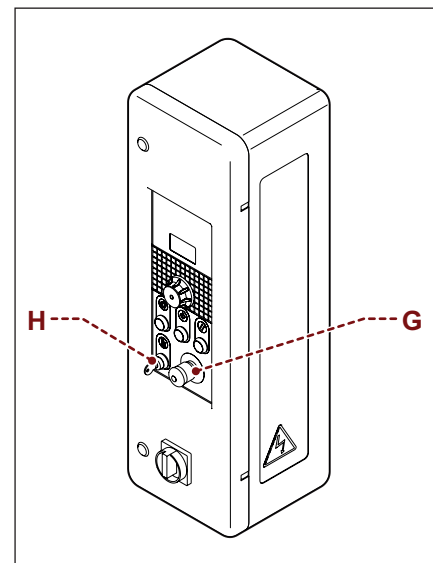
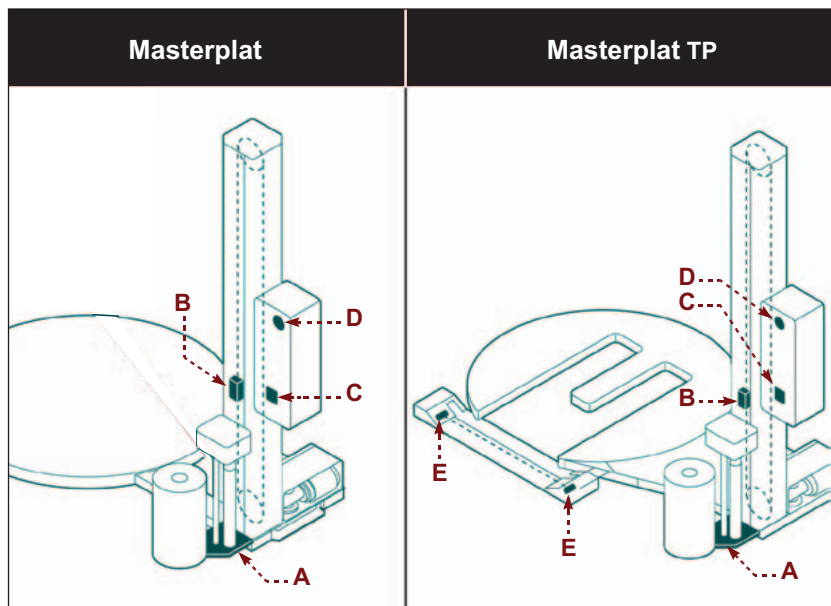

TECHNICAL INFORMATION

3.4. DESCRIPTION OF THE ELECTRICAL DEVICES

The figure shows the positioning of the devices on board of the machine.

- A) **Gear motor:** activates table rotation:
- B) **Gear motor:** activates movement of the spool carriage.
- C) **Carriage limit stop microswitch:** activates when the reel carriage reaches the minimum and maximum wrapping height.
- D) **Micro-switch:** it stops the descent when there are obstacles under the roll-holder carriage.
- E) **Photocell:** detects the presence and the height of the load to be wrapped.
- G) **'Load cell' sensor:** it detects the tension of the film and enables the speed variation of the pre-stretching rollers.
- H) **Electric motor:** it drives the pre-stretch rollers.
- L) **Sensor:** enables the in phase stop of the rotary table:
- M) **Trolley lifting sensor:** it defines the position in which to stop the trolley to start processing.

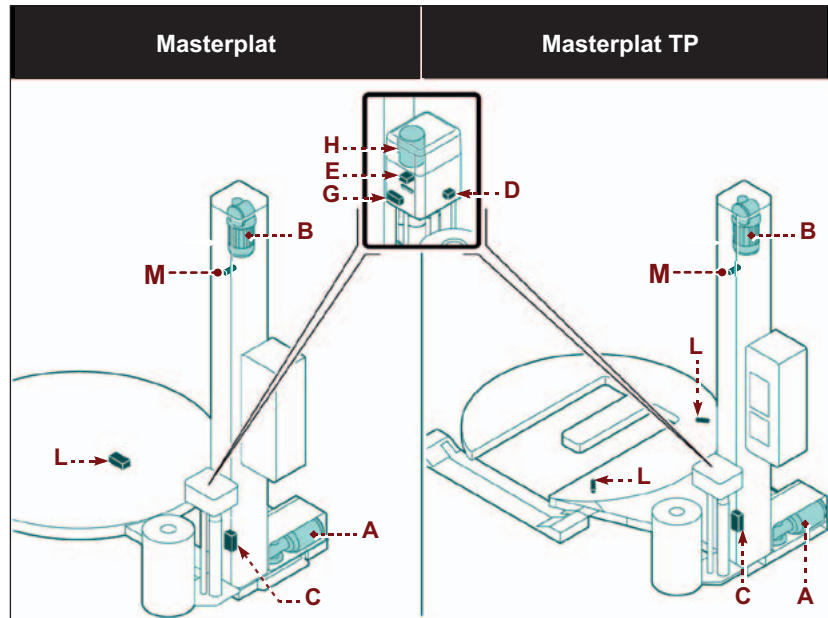

 Important

For further details see the electrical diagram.

TECHNICAL INFORMATION

3.5. DESCRIPTION OF ACCESSORIES ON REQUEST

To enhance the performance and to increase the versatility of the machine, the manufacturer furnishes the accessories listed below.

- **Pneumatic pressure platen (A):** pneumatically controlled device to stabilise the load. It is equipped with a rod pneumatic cylinder (max 800 mm stroke). It is necessary to adjust the height depending on the dimensions of the product to be wrapped. For its operation, it is necessary to have an air distribution system.

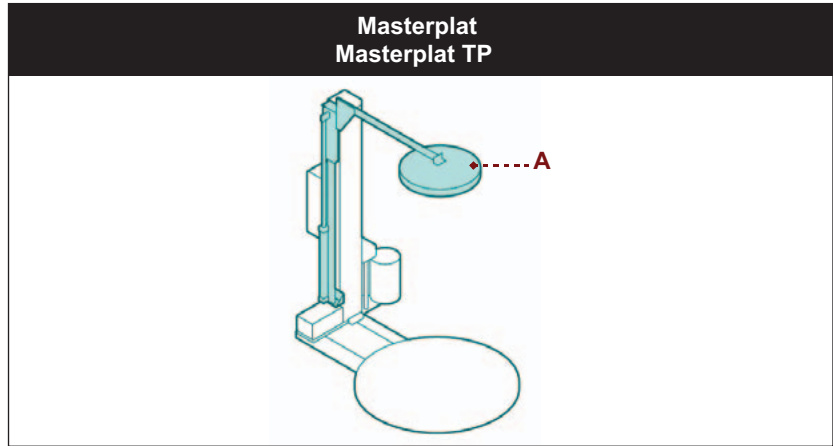

- **Platform loading/unloadingramp (B):** to facilitate these operations using forklift devices (pallet jack).

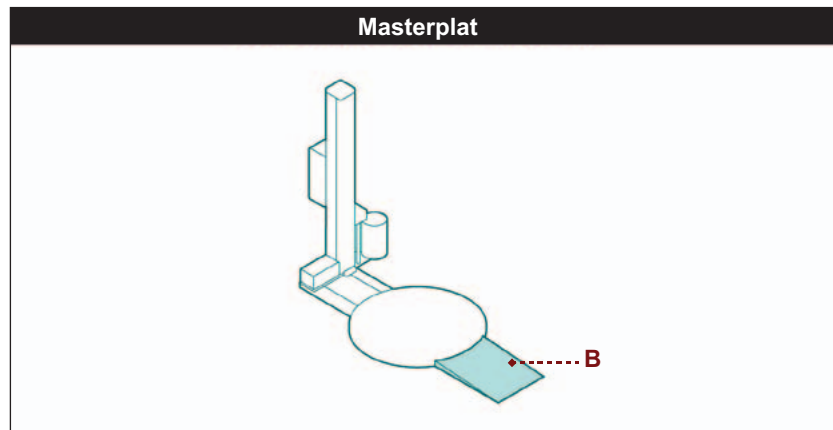

- **Lifting frame:** structure allowing to lift the machine from the ground, if the floor needs to be washed, or if it is required to use electric pallet trucks for loading.

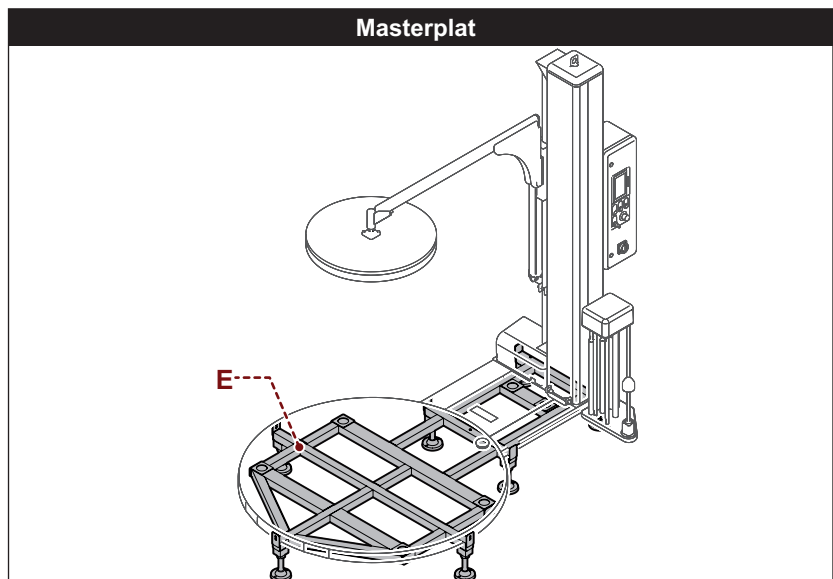

TECHNICAL INFORMATION

- **Template:** precisely shaped structure to set the machine base in the ground.
- **Rotating table (ø1800):** towrap larger than standardloads.
- **Braked axle (only for spool carriages “FRD”):** it is used to obtain a correct tensioning of the wire support.
- **Sliding guide mast (2400 - 2800 - 3100 mm):** to wrap taller than standard loads.
- **Film reinforcing device:** it is used to reinforce the film at the base of the product or on the pallet.

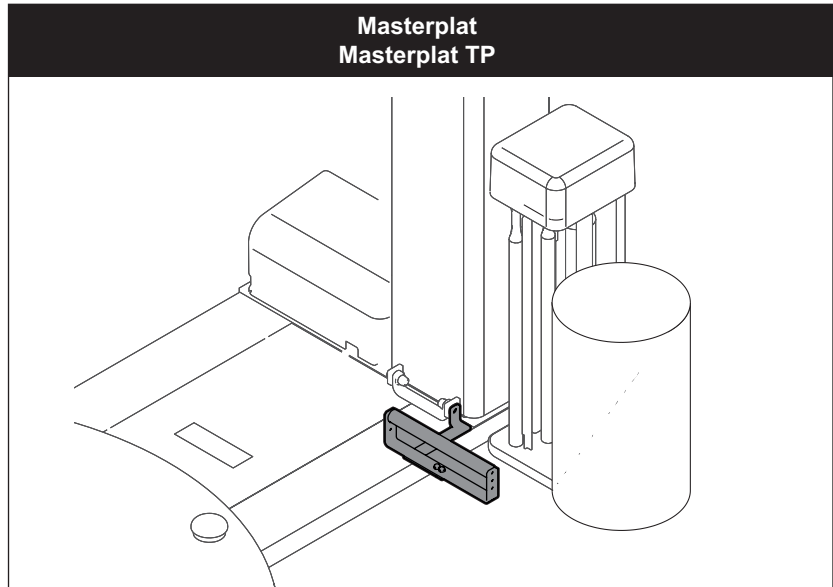

- **Coil carrier axis D=50 and D=76 for coils without a core.**

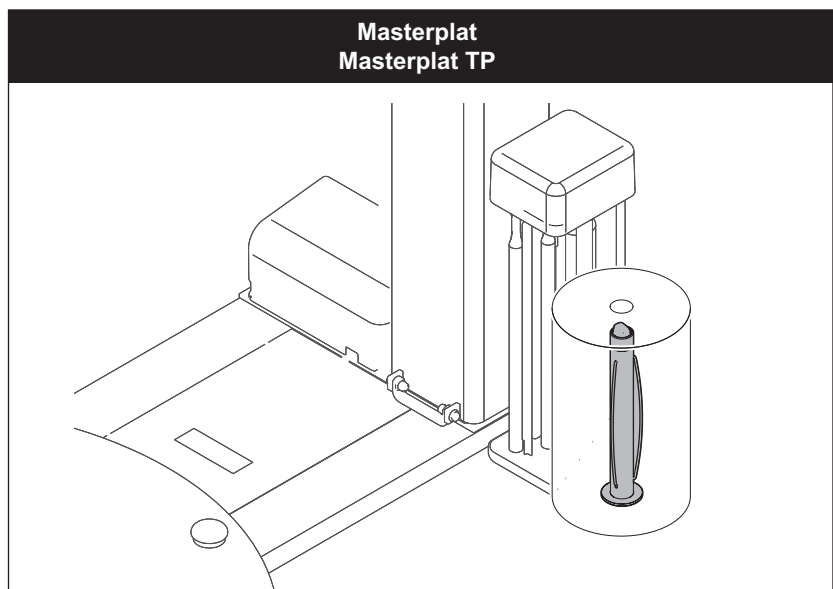

TECHNICAL INFORMATION

**3.6. TECHNICAL SPECIFICATIONS
“MASTERPLAT FRD” AND “PGS”**

The figure and table specify the dimensional characteristics and technical data of the machine.

FRD

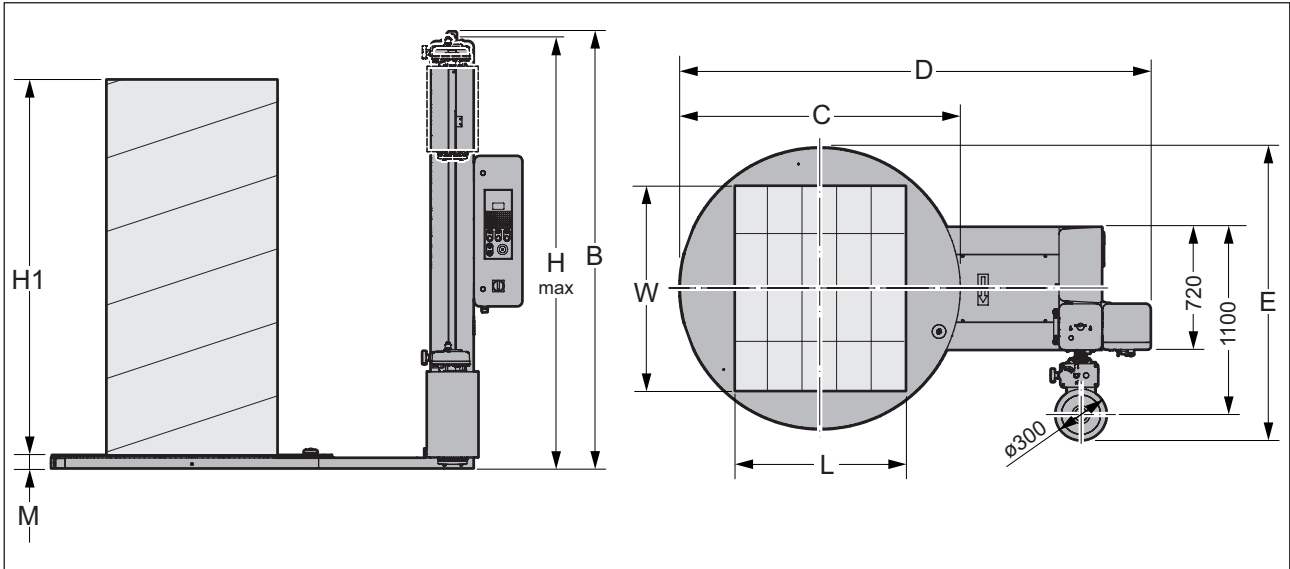

PGS

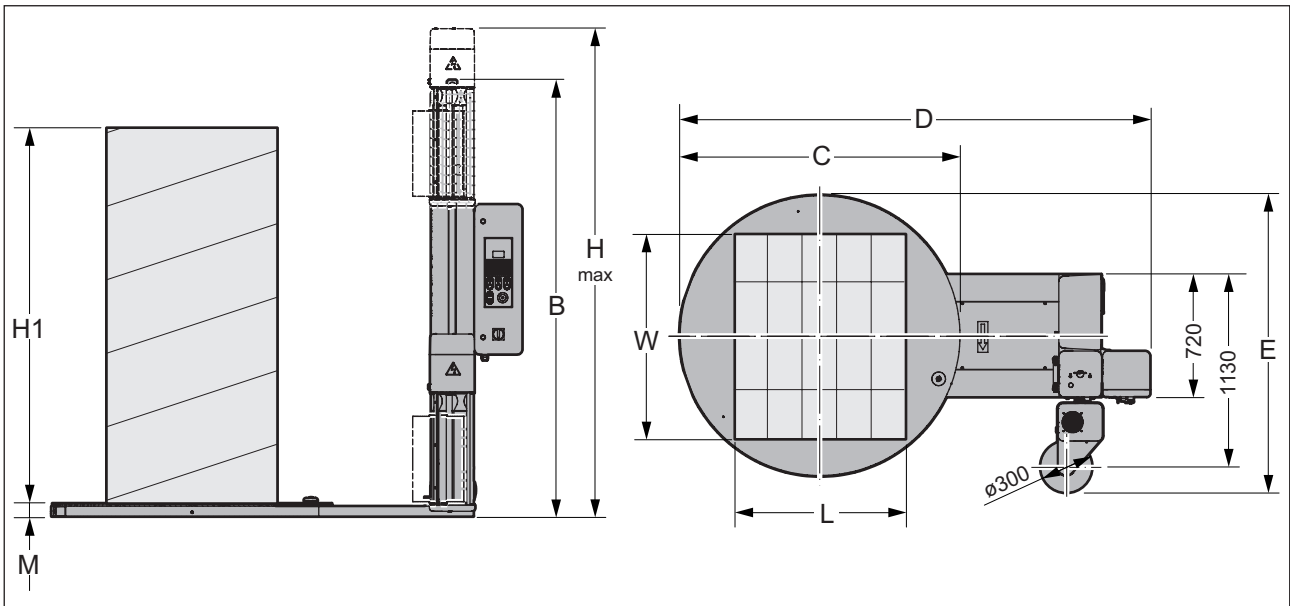

TECHNICAL INFORMATION

Table 3.3.: Machine and pallet dimensions

Machine model	Masterplat FRD				Masterplat PGS				Masterplat PGS USA			
	Std.	Opt.	Opt.	Opt.	Std.	Opt.	Opt.	Opt.	Std.	Opt.	Opt.	Opt.
Shaft height	2200	2400	2800	3100	2200	2400	2800	3100	2200	2400	2800	-
A												
H max carriage	2530	2730	3130	3430	2865	3065	3465	3765	2865	3065	3465	-
B	2560	2760	3160	3460	2560	2760	3160	3460	2560	2760	3160	-
H1	2200	2400	2800	3100	2200	2400	2800	3100	2200	2400	2800	-
M	77,5	77,5	77,5	77,5	77,5	77,5	77,5	77,5	77,5	77,5	77,5	-
Overall dimensions of load	∅1650	∅1800	-	-	∅1650	∅1800	-	-	∅1650	-	-	-
C	1650	1800	-	-	1650	1800	-	-	1650	-	-	-
D	2760,5	2835,5	-	-	2760,5	2835,5	-	-	2760,5	-	-	-
E	1715	1790	-	-	1745	1820	-	-	1745	-	-	-
F												
G												
N												
L	1000	1200	-	-	1000	1200	-	-	1000	-	-	-
W	1200	1200	-	-	1200	1200	-	-	1200	-	-	-
Weight (kg)	2000	2000	-	-	2000	2000	-	-	2000	-	-	-

Table 3.4.: Machine technical specifications.

Description	Units of measurement	Value
Supply voltage.	V	220-240 1Ph
		220-240 3Ph
		380-415 3Ph+N
		120 1Ph (for USA)
Electrical supply frequency	Hz	50/60 60 (for USA)
Installed power	kW	1,5 (Masterplat FRD)
		1,9 (Masterplat PGS)
Table rotational speed	rpm	C = 1650 5 - 12
		C = 1800 5 - 11
Carriage up/down speed.	M/min.	1,4 - 4
Maximum load	kg	2000
Total weight	kg	395÷455
Ambient operating temperature.	°C	0÷40
Ambient operating temperature (Model Freezer)	°C	-30 ÷ +40 ⁽¹⁾

⁽¹⁾ Upon request also the model "INOX" can operate at this temperature.

Table 3.5.: Presser technical specifications

Description	Value
Operating pressure	6 (±1) bar (0,6±0,1 MPa)
Rod pneumatic cylinder.	H = 2200/2400 2800/3100 Air consumption 11 NI/min.

TECHNICAL INFORMATION

3.7. COIL TECHNICAL SPECIFICATIONS
“MASTERPLAT FRD” AND “PGS”

Table 3.6.: Coil technical specifications

Description	Units of measurement	Value
Film spool dimensions (A)		
Maximum external diameter (D).	mm	300
Reel height (H).	mm	500
Film thickness.	μm	17-35
Internal diameter (d).	mm	76
Max weight	kg	20
Net spool dimensions (B).		
Maximum external diameter (D).	mm	300
Reel height (H).	mm	500
Internal diameter (d).	mm	76
Max weight	kg	20

TECHNICAL INFORMATION

**3.8. TECHNICAL SPECIFICATIONS
“MASTERPLAT TP FRD” AND “PGS”**

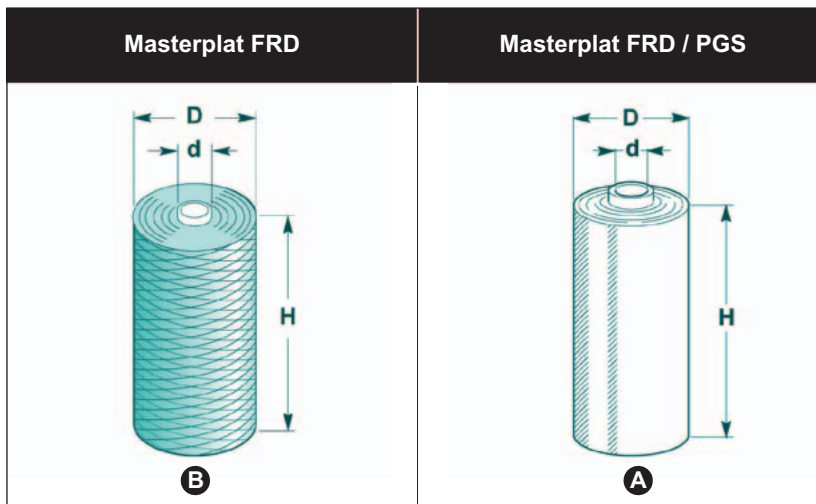
The figure and table specify the dimensional characteristics and technical data of the machine.

FRD

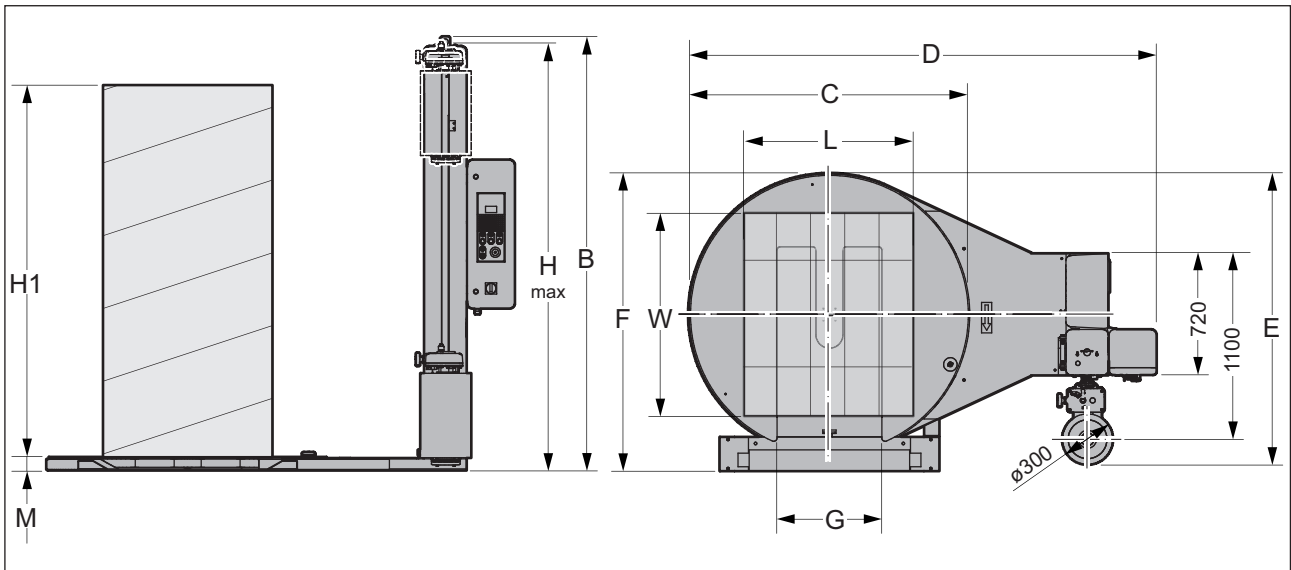

PGS

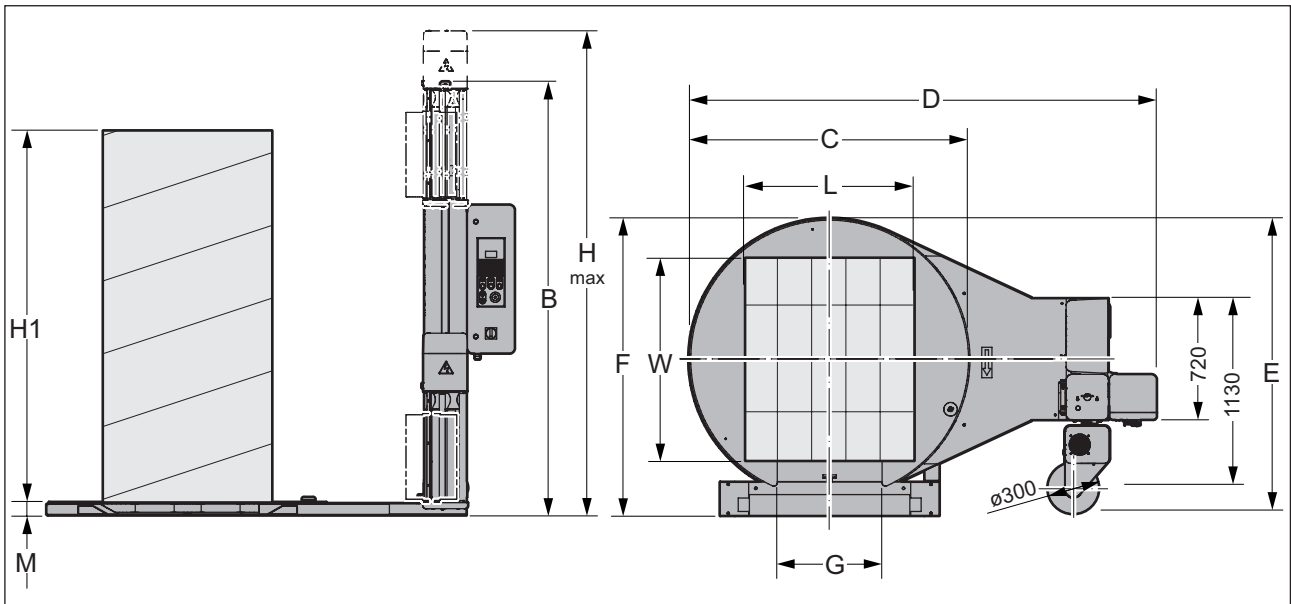

TECHNICAL INFORMATION

Table 3.7.: Machine and pallet dimensions

Machine model	Masterplat TP FRD				Masterplat TP PGS			
	Std.	Opt.	Opt.	Opt.	Std.	Opt.	Opt.	Opt.
Shaft height	2200	2400	2800	3100	2200	2400	2800	3100
A								
H max carriage	2540	2740	3140	3440	2875	3075	3475	3775
B	2570	2770	3170	3470	2570	2770	3170	3470
H1	2200	2400	2800	3100	2200	2400	2800	3100
M	73,5	77,5	77,5	77,5	77,5	77,5	77,5	77,5
Overall dimensions of load	ø1500	ø1650	ø1800	-	ø1650	ø1800	-	-
C	1500	1650	1800	-	1650	1800	-	-
D	2625	2775	2850	-	2775	2850	-	-
E	1650	1725	1800	-	1755	1830	-	-
F	1645	1765	1950	-	1765	1950	-	-
G	620	620	620	-	620	620	-	-
N								
L	800	1000	1200	-	1000	1200	-	-
W	1200	1200	1200	-	1200	1200	-	-
Weight (kg)	1200	1500	1500	-	1500	1500	-	-

Table 3.8.: Machine technical specifications.

Description	Units of measurement	Value
Supply voltage.	V	220-240 1Ph
		220-240 3Ph
		380-415 3Ph+N
Electrical supply frequency.	Hz	50/60
Installed power.	kW	1,5 (Masterplat TP FRD)
		1,9 (Masterplat TP PGS)
Table rotational speed	rpm	C = 1650 5 - 12
		C = 1800 5 - 11
Carriage up/down speed.	M/min.	1,4 - 4
Maximum load.	kg	1500
Total weight.	kg	525 (Masterplat TP FRD)
		550 (Masterplat TP PGS)
Ambient operating temperature	°C	0÷40
Ambient operating temperature (Model Freezer)	°C	-30 ÷ +40 ⁽¹⁾

⁽¹⁾ Upon request also the model "INOX" can operate at this temperature.

Table 3.9.: Presser technical specifications

Description	Value
Operating pressure	6 (±1) bar (0,6±0,1 MPa)
Rod pneumatic cylinder.	H = 2200/2400 2800/3100 Air consumption 11 NI/min.

TECHNICAL INFORMATION

3.9. COIL TECHNICAL SPECIFICATIONS
“MASTERPLAT TP FRD” AND “PGS”

Table 3.10.: Coil technical specifications

Description	Units of measurement	Value
Film spool dimensions (A)		
Maximum external diameter (D)	mm	300
Reel height (H)	mm	500
Film thickness	µm	17-35
Internal diameter (d)	mm	76
Max weight	kg	20
Net spool dimensions (B)		
Maximum external diameter (D)	mm	300
Reel height (H)	mm	500
Internal diameter (d)	mm	76
Max weight	kg	20

TECHNICAL INFORMATION

3.10. NOISE LEVEL

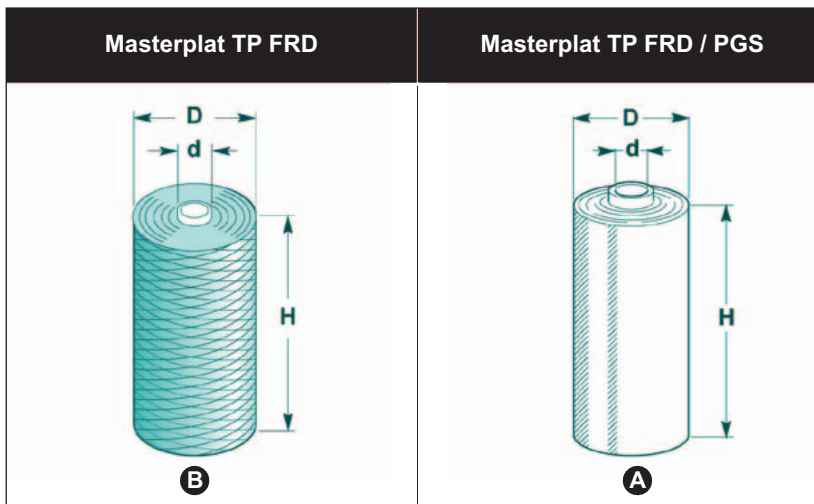
The noise levels were measured in compliance with the standards.

- ISO 4871
- ISO 11201

<i>Description</i>	<i>Measured level of A weighted emission sound pressure, in the operator position (LpA)</i>
Functioning in working conditions.	69,3 dB (A)

**Caution - Warning**

Prolonged exposure over 80 dB (A) may cause health problems. The use of appropriate protection systems is recommended (headphones, ear plugs, etc.)

3.11. INSTALLATION ENVIRONMENT CHARACTERISTICS

Careful consideration must be given to the place where the machine is to be installed, in order to ensure that it may be easily operated, without creating any unnecessary risks for personnel. Therefore we suggest the following prerequisites.

- Suitable room temperature (See 3.6. "Technical data "Masterplat FRD" and "PGS"" - 3.8. "Technical data "Masterplat TP FRD" and "PGS"").
- A suitably aired place so that when the machine is working, the degree of humidity is not unpleasantly high/low from the point of view of the operator.
- A sufficient lighting in order that a pleasant, relaxing working environment is created for the operator.
- A boundary area that must be left around the machine for safety reasons (See 2.8. "Surrounding areas").
- A flat surface, steady and without vibrations with adequate weight supporting capacity, also in consideration of the palletised loads to be wrapped.
- The area must be equipped with a power supply socket and a compressed air supply socket.

**Danger - Warning**

Use of this machine in explosive environments or when exposed to the elements is strictly forbidden.

INFORMATION ON HANDLING AND INSTALLATION OPERATIONS

4.1. RECOMMENDATIONS FOR HANDLING AND LOADING

- Before performing any operation, the authorised operator must make sure that he/she understood the “Instructions for use”.
- Carefully read the “Instructions for use” specified in the manual and those applied directly to the machine and/or the package.
- Provide suitable safety conditions in compliance with the regulations on workplace safety to prevent and minimise the risks.
- Pay attention to the **SAFETY WARNINGS**, do not use the machine for **UNSPECIFIED PURPOSES** and assess the possible **RESIDUAL RISKS**.

4.2. PACKAGING AND UNPACKING

The packing is realised, keeping the overall dimensions low, also in consideration of the transport chosen

To facilitate transport, shipping can be performed with some components disassembled and appropriately protected and packaged

Some parts, especially electric equipment, are protected with anti-moisture nylon covers.

The cases are marked with all necessary information for loading and unloading.

During unpacking, check the integrity and exact quantity of components.

Packaging material should be appropriately disposed according to the laws in force.

The figures show the most commontypes of packages.

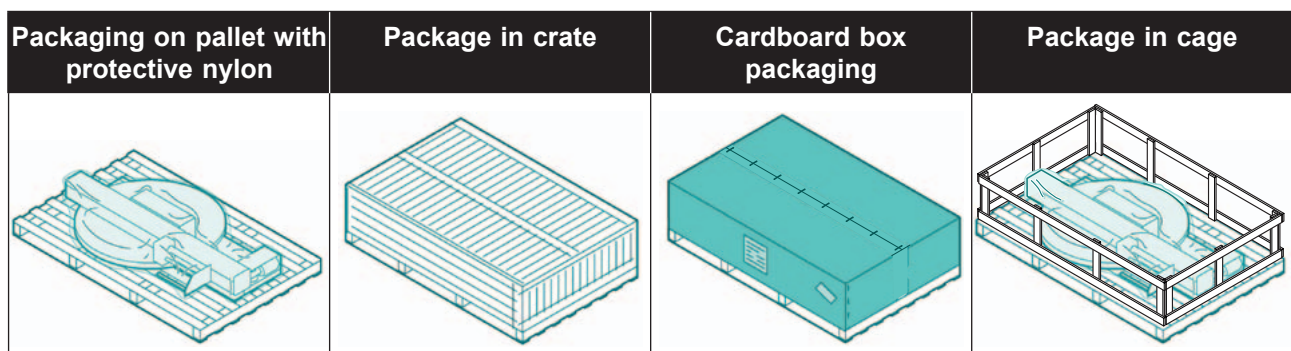

INFORMATION ON HANDLING AND INSTALLATION OPERATIONS

4.3. TRANSPORT AND HANDLING

Transport, also according to the destination, can be performed by different vehicles.

The diagram represents the most popular solutions.

During transport, with the purpose to avoid sudden movements, adequately anchor the machinery to the means of transportation

 Important
For further transportation, recreate the initial packaging conditions for transport and handling.

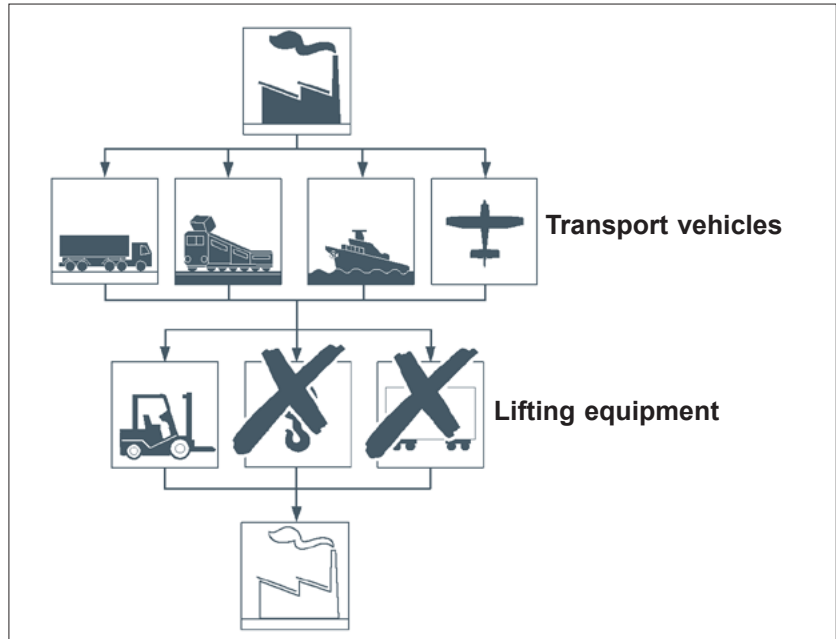

4.4. INSTALLATION OF DISMANTLED PARTS

Following are the steps to be taken to install dismantled parts

Electrical box assembly

Proceed as indicated

1. Cut the band (A) that holds the electrical wires together.
2. Remove the blocking rods (B).
3. Insert the electrical wires (C) in the slide shaft.
4. Lift the electrical box (D).
5. Fasten the electrical box to the slide mast using the screws (E).
6. Close the cover (D) of the electrical box (F) with the key (G).

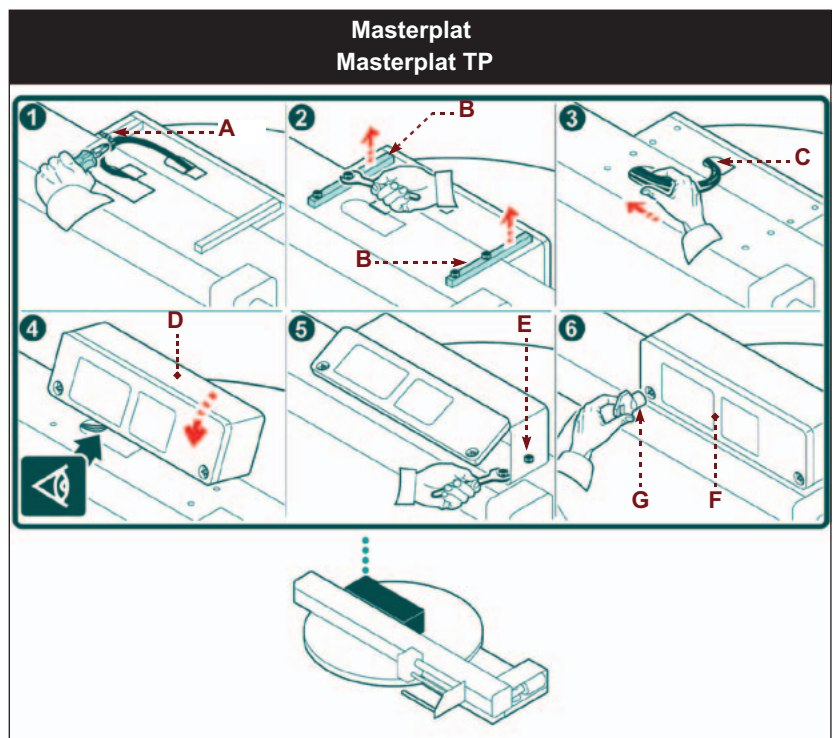

INFORMATION ON HANDLING AND INSTALLATION OPERATIONS

Slide guide mast assembly

1. Lift and position the slide guide mast (**H**) over the rotating table in correspondence with the hinge.
2. Insert the screws (**L**) in the hinge without tightening them (Only forsliding shaft with height 2800-3100 mm).

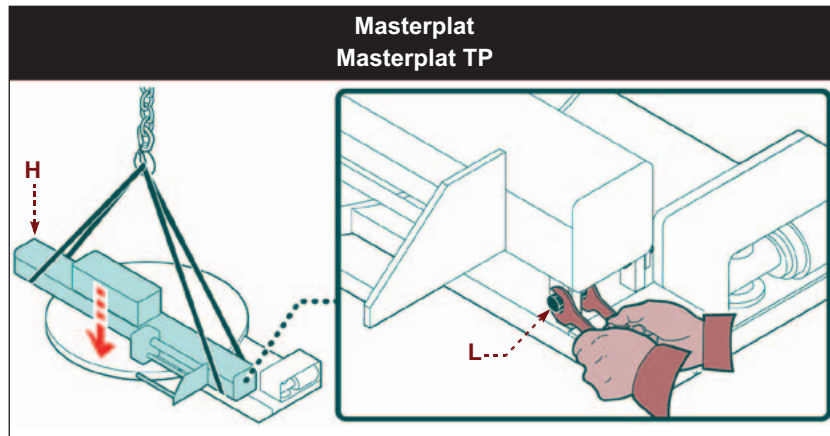

3. Secure the hook of the lifting equipment to the bracket (**M**) of the sliding mast and tension it (Only forsliding shaft with height 2200-2400 mm).
4. Lift the sliding mast (**H**).
5. Secure the sliding mast to the machine body with the screws (**N**).
6. Tighten the hinge screws (**L**).

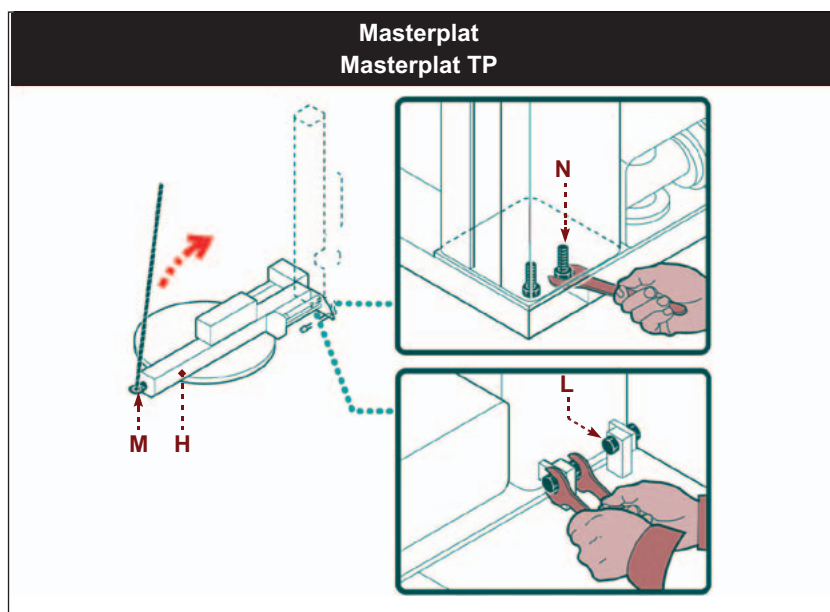

Loading/unloading ramp assembly

Assemble the platform loading/unloading ramp (**Y**) and connect the supply connector (**Z**).

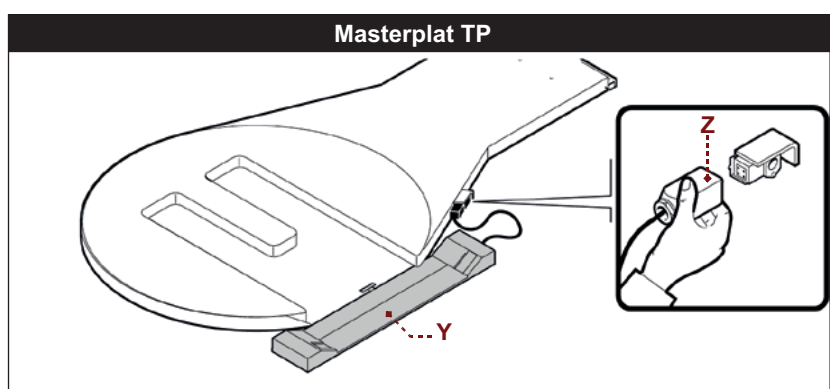

INFORMATION ON HANDLING AND INSTALLATION OPERATIONS

**Pneumatic presser assembly
(optional)**

1. Fasten the guide (**P**) to the slide guide mast with the screws (**Q**).
2. Assemble the arm (**R**) to the guide and fasten with the screws (**S**).
3. Assemble the presser plate (**T**) to the arm.



Important

If the pressure platen is delivered with the machine, the pneumatic connections have already been performed by the manufacturer.

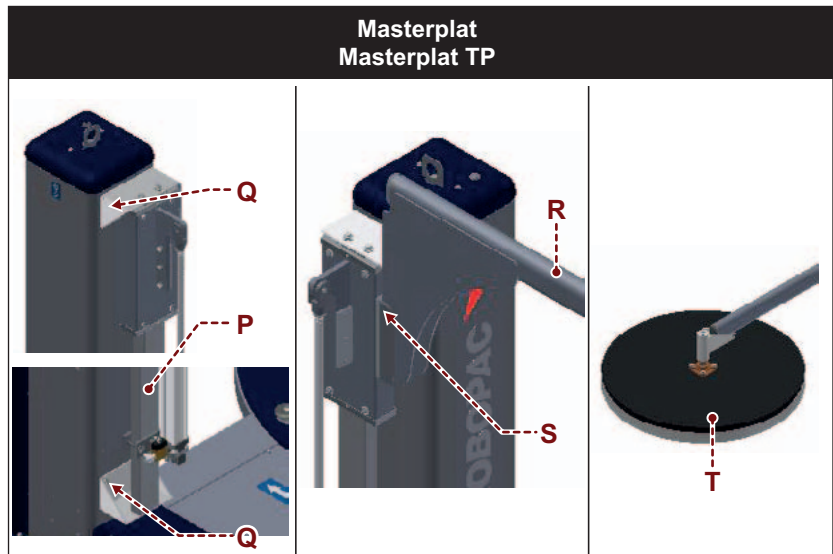

INFORMATION ON HANDLING AND INSTALLATION OPERATIONS

4.5. FASTENING THE MACHINE

- When you have finished assembling the units and checking the levels, squaring, parallelism, and orthogonal shape, you must fasten the machine body onto the floor.
- Depending on the characteristics of the flooring, it may be necessary, before positioning the machine, to create foundations at the points of the various support legs. The creation of the foundations and the fastening of the machine are fundamental operations for ensuring the stability and correct functioning of the machine.

 Important

If necessary, insert metal plates (A) between the screws and the floor.

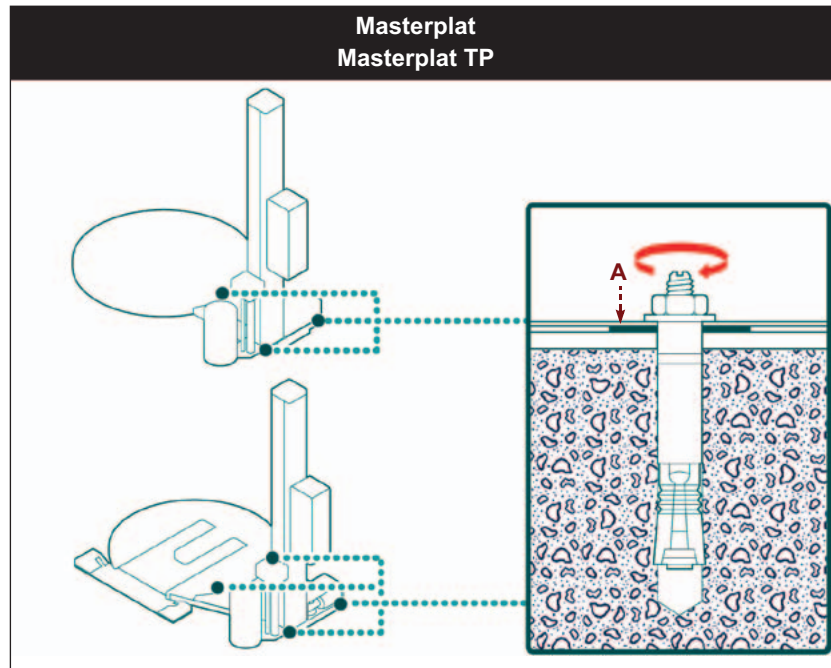
**4.6. SETTING THE MACHINE INTO THE GROUND**

Dig out a ditch in the floor in which to place the template (C) and cast cement to fasten it into place.

Template (C) is supplied on request (Optional).

 Important

The depth (X) must be equal to the height of the machine's base plate.

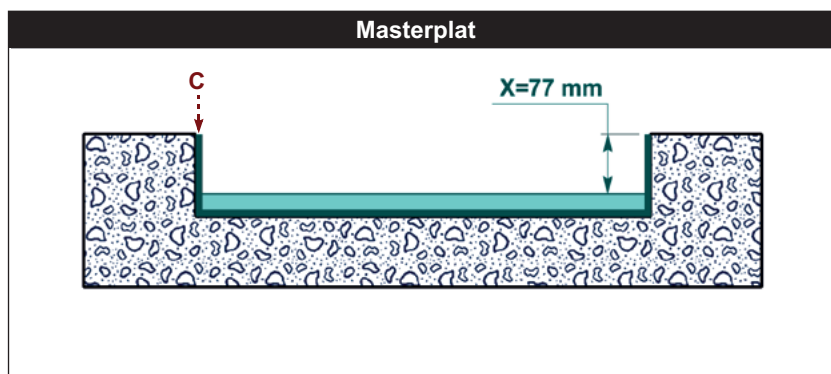

4.7. RECOMMENDATIONS FOR CONNECTIONS

Important

Connections should be performed following the manufacturer's indications in the enclosed diagrams. Personnel authorised to perform this operation must possess technical skills, abilities and have acquired certified experience in the specific field and must perform connections professionally, taking into account all the regulative and legislative requirements. When connections are completed, make sure these requisites were observed by performing a general inspection before making the unit operative.

4.8. PNEUMATIC CONNECTIONS

Proceed as indicated.

1. Insert a flexible tube on the end of the rubber fitting and fasten it with a metallic screw clamp (A).
2. Check that the valve (B) is in the "OPEN" position.
3. Turn on the power supply line.
4. Check that the manometer reads a pressure of at least **6 bar** and turn knob (C) to compensate any pressure differences.

Repeat this operation with the machine running.

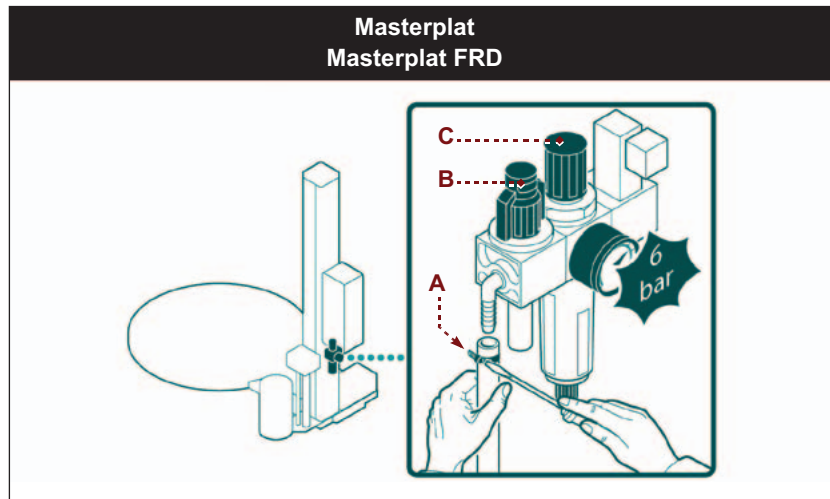

INFORMATION ON HANDLING AND INSTALLATION OPERATIONS

4.9. ELECTRICAL CONNECTION

Proceed as follows for electrical connections

1. Check that the mains voltage (**V**) and frequency (hertz) correspond to those of the machine (see identification plate and wiring diagram).
2. Turn the mains switch to **0 (OFF)**.
3. Connect the power cord to the outlet (**A**), as illustrated, according to the network mains
4. The earth wire (yellow and green) must be connected to its earth terminal PE.
5. Turn on machine with main switch
6. Press the "Reset" button .
7. If you press the "START" button, the plate must rotate in a clockwise direction

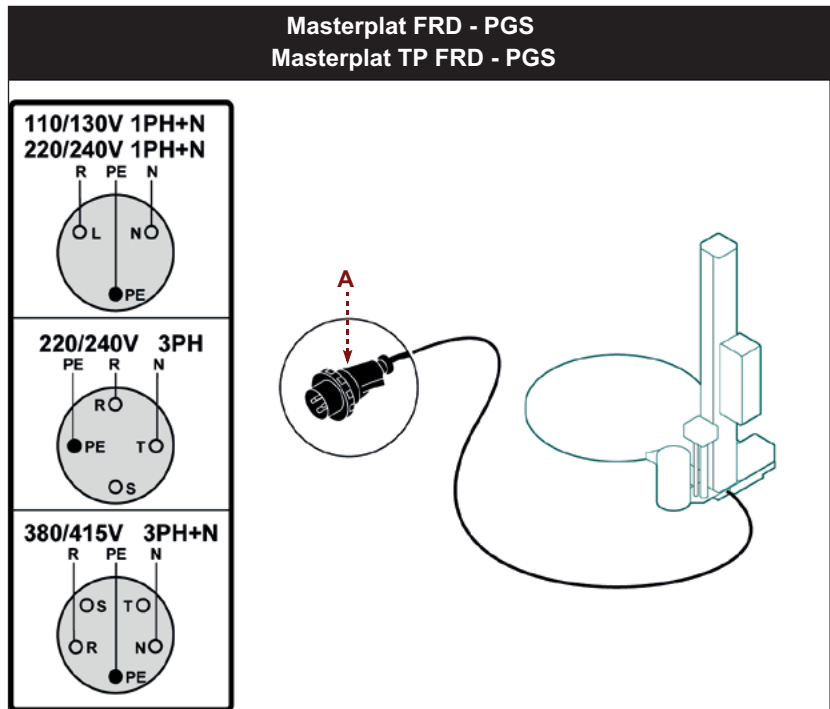

INFORMATION ON ADJUSTMENTS

5.1. RECOMMENDATIONS FOR ADJUSTMENTS

- Before performing any operation, the authorised operator must make sure that he/she understood the “Instructions for use”.
- Before carrying out any intervention, activate all the safety devices provided, stop the machine and assess if any residual energy is still present.
- Provide suitable safety conditions in compliance with the regulations on workplace safety to prevent and minimise the risks.
- Pay attention to the **SAFETY WARNINGS**, do not use the machine for **UNSPECIFIED PURPOSES** and assess the possible **RESIDUAL RISKS**.

5.2. ADJUSTING FILM “STRETCH”

“FRD” type reel carriages

1. Use lever **(A)** to lock and unlock roller **(B)**
2. Adjust hand wheel **(C)** to regulate the braking effect of the pre-stretch roller **(B)** that determines film lengthening.

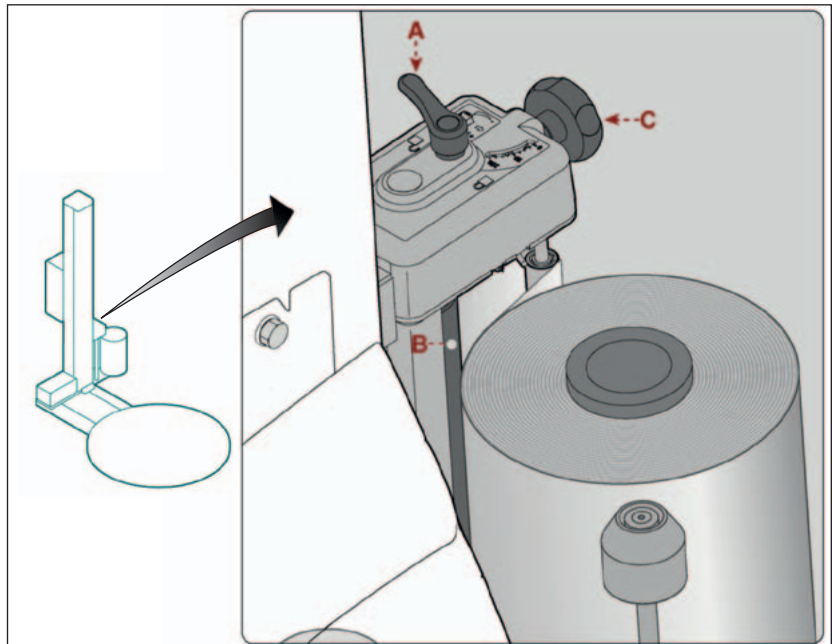

INFORMATION ON ADJUSTMENTS

"PGS" type reel carriages - Replace the drawing gears

Proceed as indicated.

1. Stop the machine in safety conditions.
2. Remove transmission cover (A).
3. Loosen the belt (C) through the tensioner (B).
4. Remove the belt from the pulley (D).
5. Loosen the screws (E).
6. Remove the disk (F) including the motor and bearings.

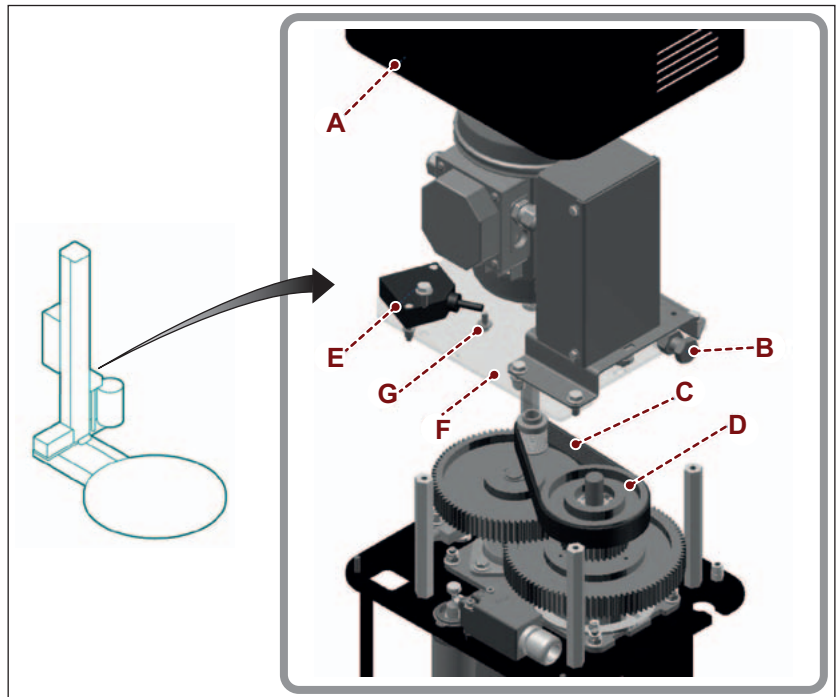

7. Remove the stopping ring (G).
8. Remove the pulley (D).
9. Remove the stopping ring (H).
10. Remove the gear (L).
11. Remove the stopping ring (M).
12. Remove the gear (N).
13. Unscrew the screws and dismantle the spacer (P) from the gear (N).
14. Select the couple of gears (L-N) relating to the pre-stretch percentage involved (see the table).

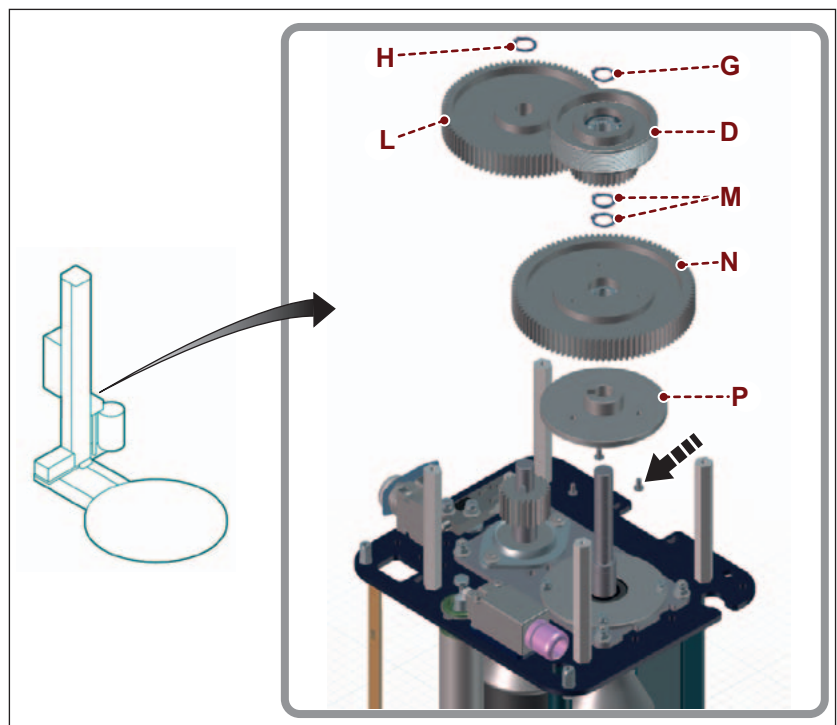

INFORMATION ON ADJUSTMENTS

The table lists the pre-stretch values obtainable with the relevant driving ratio.

**Important**

Set the pre-stretch depending on the resistance and the quality of the coating to obtain low consumption.

Table 5.1.: Pre-stretch values.

Pre-stretch percentage	Gear code (L)	No. of gear teeth (L)	Gear code (N)	No. of gear teeth (N)
150%	2540300068	34	2540300070	85
200%	2540300003	29	2540300002	90
250%	2540300165	25	2540300164	94
300%	2540300027	24	2540300028	95

15. Fix the spacer **(P)** correctly to the gear **(N)** of the new transmission ratio.
16. Assembly the gear **(N)** of the new driving ratio.
17. Position the gear with the spacer **(P)** positioned towards the carriage.
18. Assembly the stopping ring **(M)**.
19. Assembly the gear **(L)** of the new driving ratio.
20. Assembly the stopping ring **(H)**.
21. Assembly the pulley **(D)**.
22. Assembly the stopping ring **(G)**.

**Important**

During re-assembly remember to pay attention to the proper insertion of the coupling tabs.

23. Rest the disk **(F)** on the little columns paying attention to assemble the belt **(C)** on the pulley **(D)**.
24. Tighten screws **(E)**.
25. Tension the belt **(C)** through the tightener **(B)**.
26. Rotate manually the pre-stretch rollers in both directions to completely adjust the coupling between the belt and the pulleys.
27. Again check the tension of the belt and if needed strain it properly.
28. Re-assemble the casing **(A)** at the end of the operation.

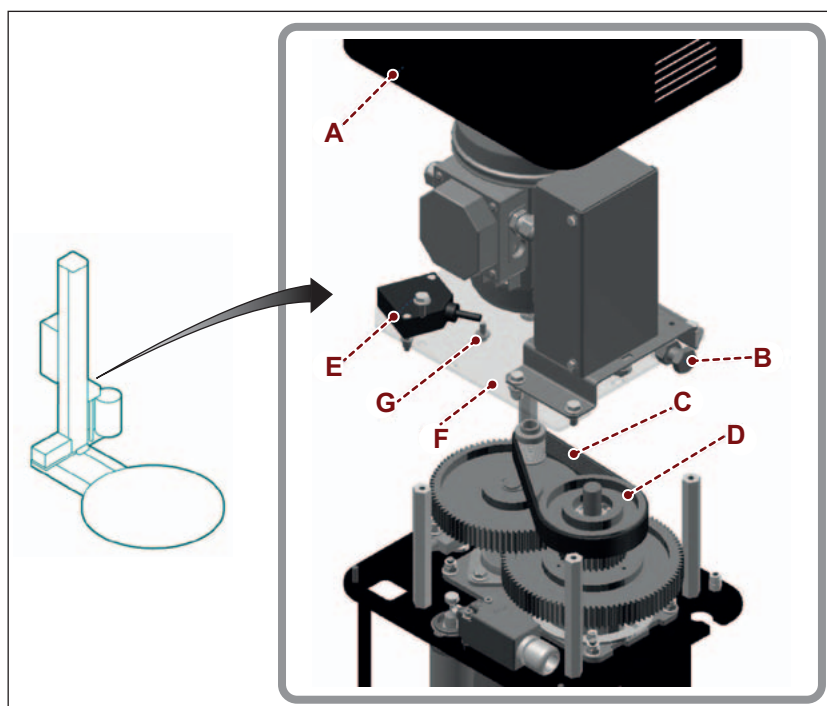

INFORMATION ON ADJUSTMENTS

“FRD” type spool carriage fornet

Act on the **(C)** handwheel until you reach the value displayed in index **(E)**.

The braked axis is an accessory that can be mounted onto the carriage even later.

This optional gives you the opportunity to operate with a “FRD” carriage the wire support coil.

**Important**

In order to obtain the correct tensioning of the wire support, adjust the braking effect so that the **(G)** output roller is more braked than the **(H)** input roller; also, to prevent the wire support from slipping on the drawing rollers, the latter should not be excessively braked.

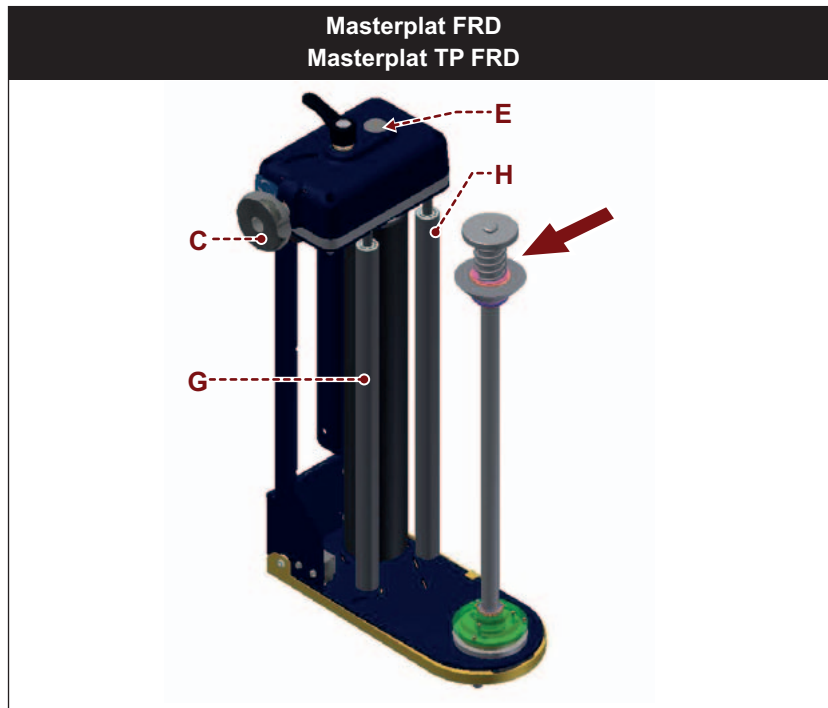
**5.3. REEL CARRIAGE LIFTING CHAIN ADJUSTMENT**

Proceed as indicated.

1. Lift the spool carriage (with machine operation set to “manual mode”) up to “top” end stroke.
2. Switch the machine off.
3. Loosen the screws **(A)** and tilt the stake resting it on the plate.
4. Remove the guard **(B)**.
5. Loosen the nuts **(C)**.
6. Tighten the screw **(D)** “M8x50 UNI 5739” (element not supplied) with a torque wrench (element not supplied) up to the torque 3 Nm.
7. Re-tighten the nuts **(C)** up to the surface of the chain tightening pulley **(E)**.
8. Undo screw **(D)**.
9. Refit the guard **(B)**.
10. Re-position the stake vertically and tighten the screws **(A)**.

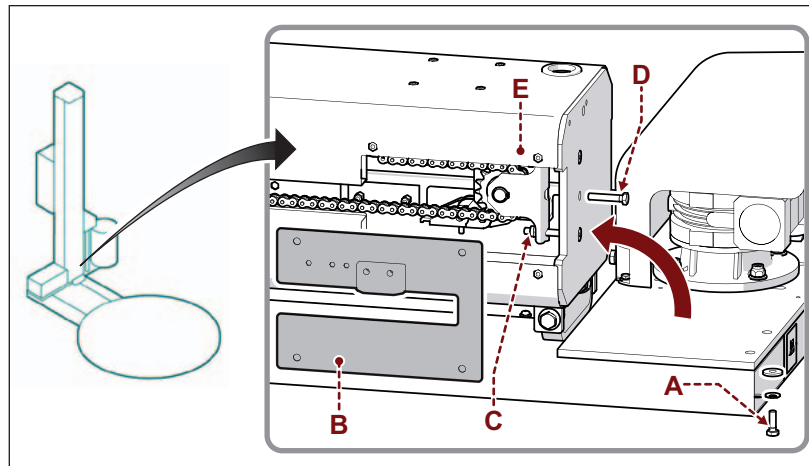

INFORMATION ON ADJUSTMENTS

5.4. TABLE ROTATION CHAIN ADJUSTMENT

Proceed as indicated.

1. Remove the cover guard (A)
2. Loosen the fastening screws (B) of the gear-box
3. Tighten the screw (C) with a torque wrench (element not supplied) up to the torque 5 Nm.
4. Tighten the reducer fastening screws (B) when finished
5. Refit guard (A).

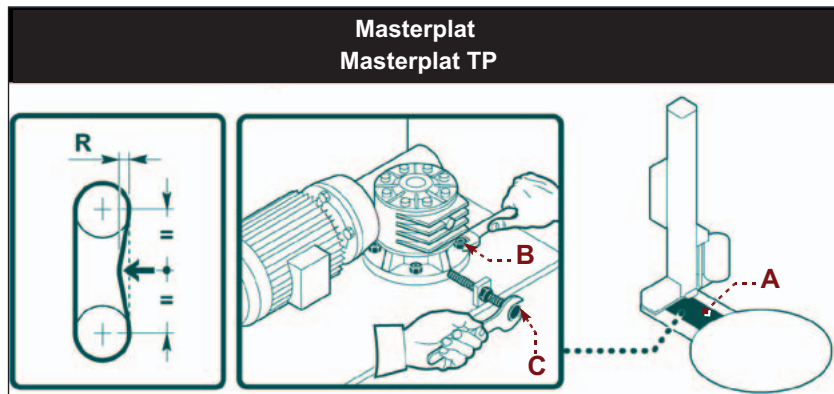

5.5. ADJUSTMENT OF TABLE GUIDE ROLLERS

Proceed as indicated.

1. Remove the cover guard (A).
2. Loosen the fastening nuts (B).
3. Loosen the screw (E).
4. Adjust screw (D) so that wheel (C) is pressed on rotary plate by about 4 mm.
5. Tighten the screw (E).
6. Tighten the nuts (B).
7. Refit guard (A).

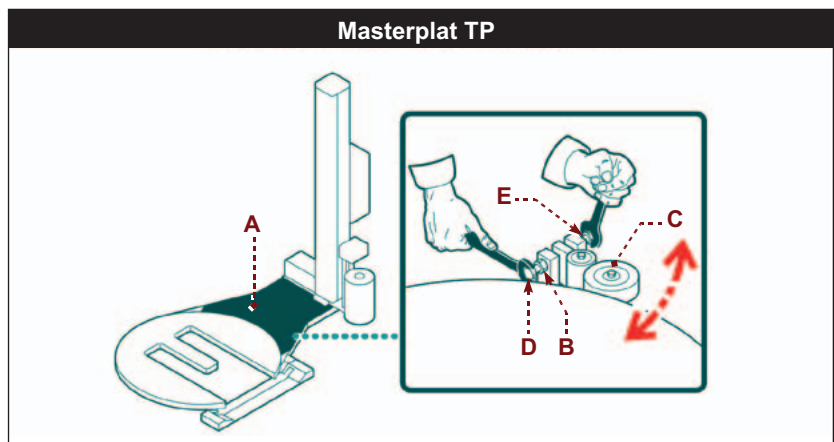

ABOUT THE USE

6.1. RECOMMENDATIONS FOR OPERATION AND USE

- Before performing any operation, the operator must make sure that he/she understood the “Instructions for use”.
- When using the machine for the first time, the operator must read the manual and identify the controls and simulate some operations, especially the start-up and shutdown.
- Check that all safety devices are installed correctly and in good working order.
- Only implement the uses intended by the manufacturer and do not tamper with any device to obtain performances different from the intended ones.

ABOUT THE USE

6.2. CONTROL DESCRIPTION

The illustration shows the main controls of the machine and the list shows their description and function.

A) Emergency stop push-button: it is used to stop with a voluntary action, in case of imminent risk, the organs of the machine that may pose a risk.

For further details consult the paragraph "Description of safety devices".

B) User interface: it is used to set or modify the operating parameters of the machine.

The user interface is equipped with display and multi-function selector (**G**).

For further details consult the paragraph "Description of the user interface".

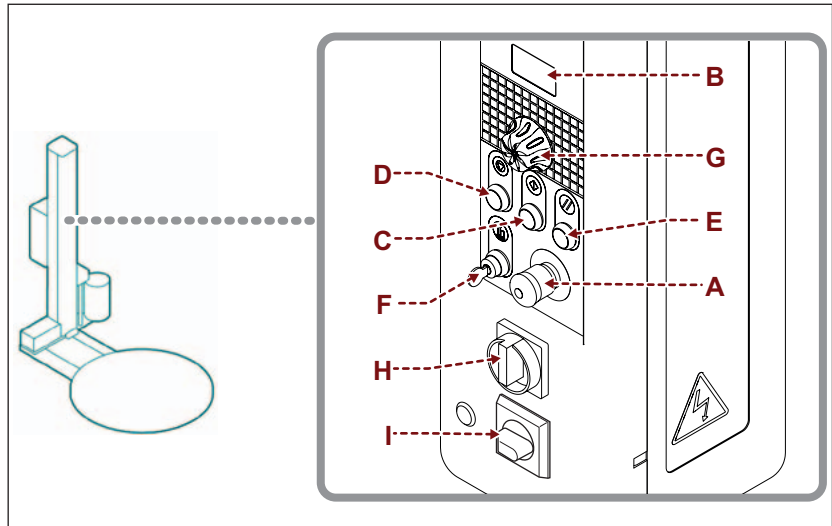

C) "Start cycle" push-button: it is used to start the automatic wrapping cycle.

D) "Stop cycle" button: it is used to stop the automatic wrapping cycle.

E) "Reset" push-button: it is used to reset the machine before restarting after an emergency stop or to restart it after stopping with power supply cut-off.

F) Key selector for emergency interruption: it is used to momentarily interrupt the emergency of the trolley. Turn the key to **I** (action maintained), on the user interface screen the page "emergency suspended" will appear that allows just the carriage to be lifted by pressing the "start" button (**C**).

G) Multi-function selector: used to activate and programme the machine functions.

Turn the selector (clockwise or anti-clockwise) and release it when the page or the relative function appears. Press to activate the selected function.

H) Master switch: to switch the electricity supply on and off.

- Pos. "**O**": power deactivated.
- Pos. "**I**": power activated.

I) Selector: used to activate and deactivate the heating of the control panel (only for version "FREEZER" and "INOX" upon request).

The heating automatically comes on and goes off at temperatures (minimum and maximum) set by the manufacturer.

- Pos. "**O**": heating deactivated.
- Pos. "**I**": heating activated.

ABOUT THE USE

6.3. DESCRIPTION OF THE USER INTERFACE

The user interface is equipped with a multi-function selector (**G**), which is used to display and programme the machine functions, and the display (**B**), which displays the recipes, parameters, etc...

To display and/or programme the functions, turn or press the multi-function selector.

The list shows the ways for displaying the functions.

- Complete display (**ADVANCE**).
- Simplified display (**EASY**).

The functional logic diagrams illustrate the navigation modes.

In the illustration, alongside each display, there is the initials that indicate the activation mode.

- **Initials "R"**: turn the command to access the displays or to change the values.
To change the values, press the control , turn it until the relevant value is displayed and press it to save.
- **Initials "P"**: press the command to activate the selected function.

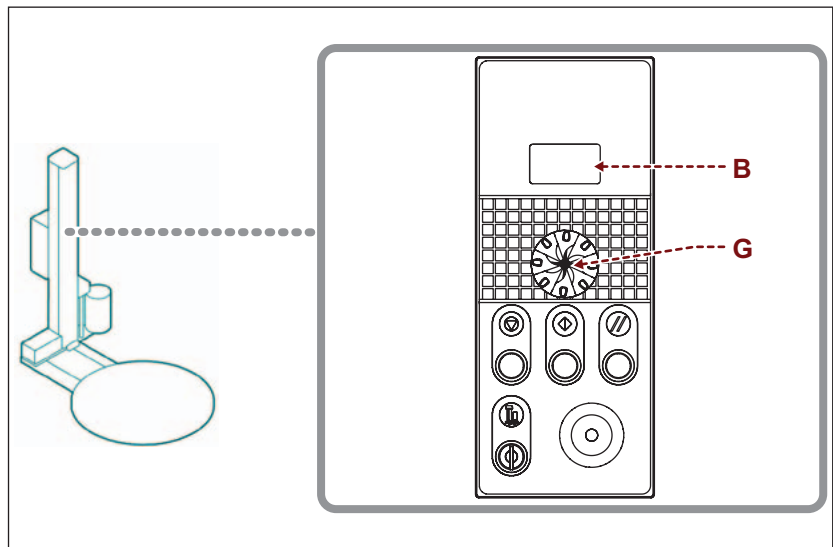

ABOUT THE USE

6.4. MAIN MENU

Complete display (ADVANCE)

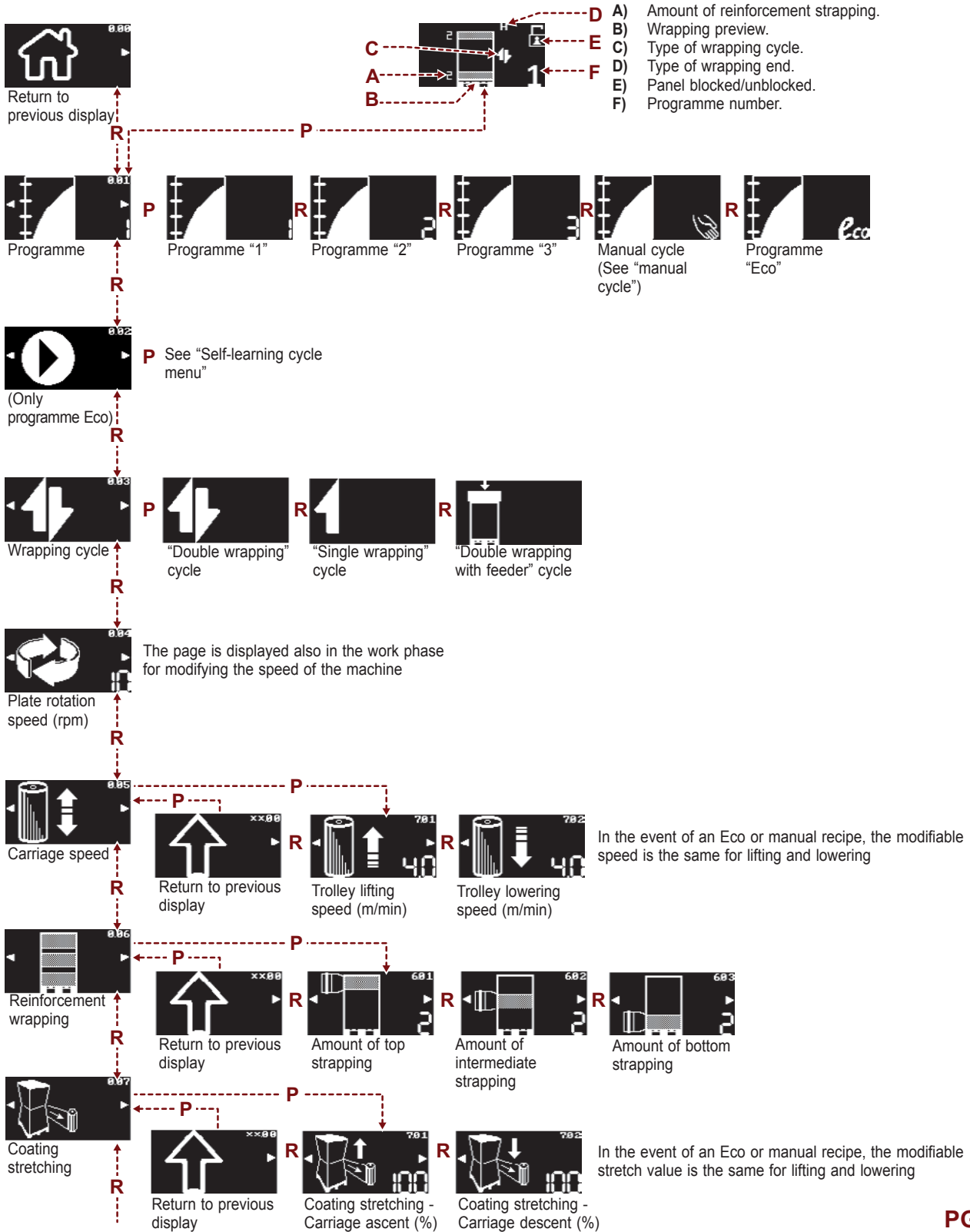

PGS

ABOUT THE USE

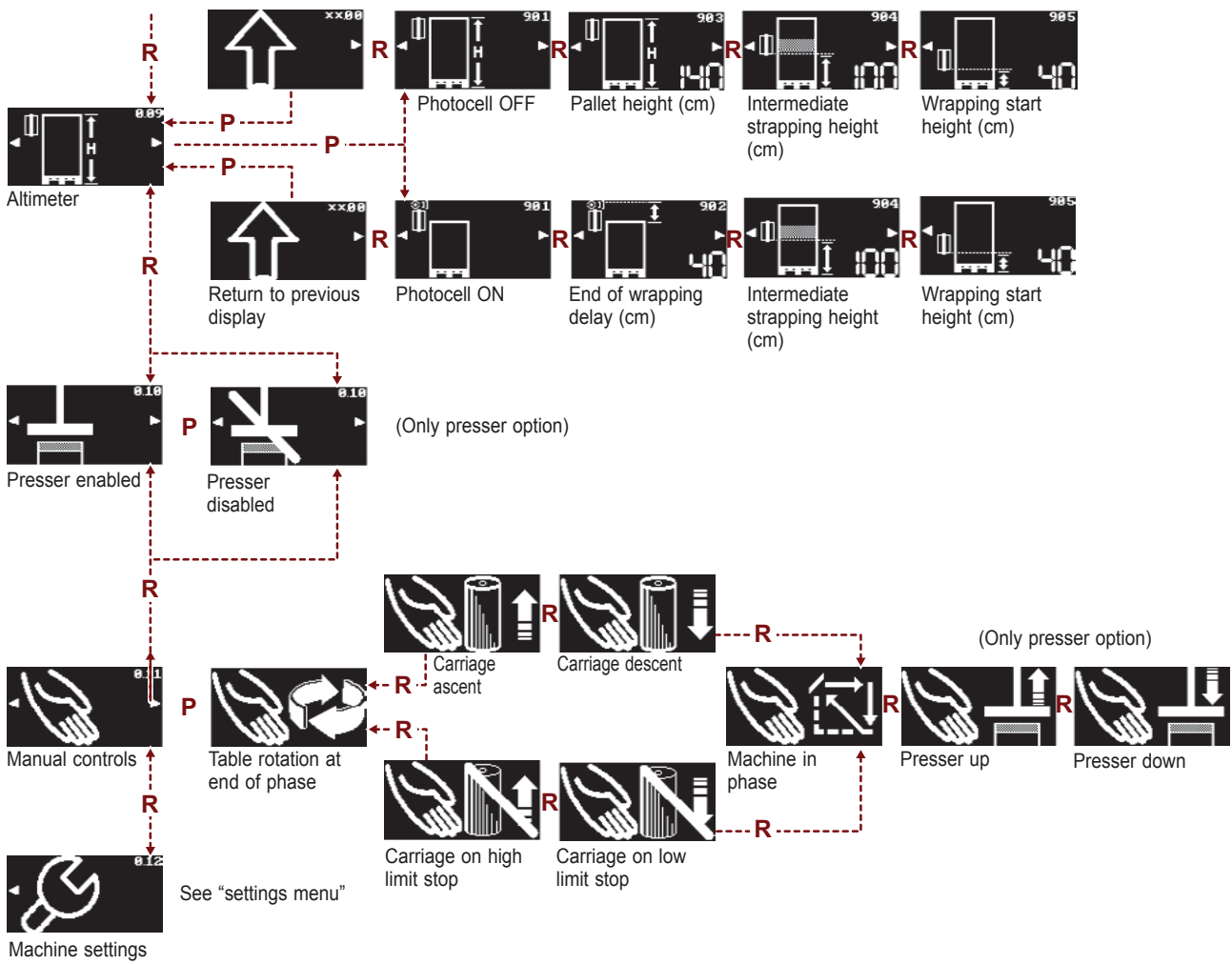

ABOUT THE USE

6.5. SETTINGS MENU

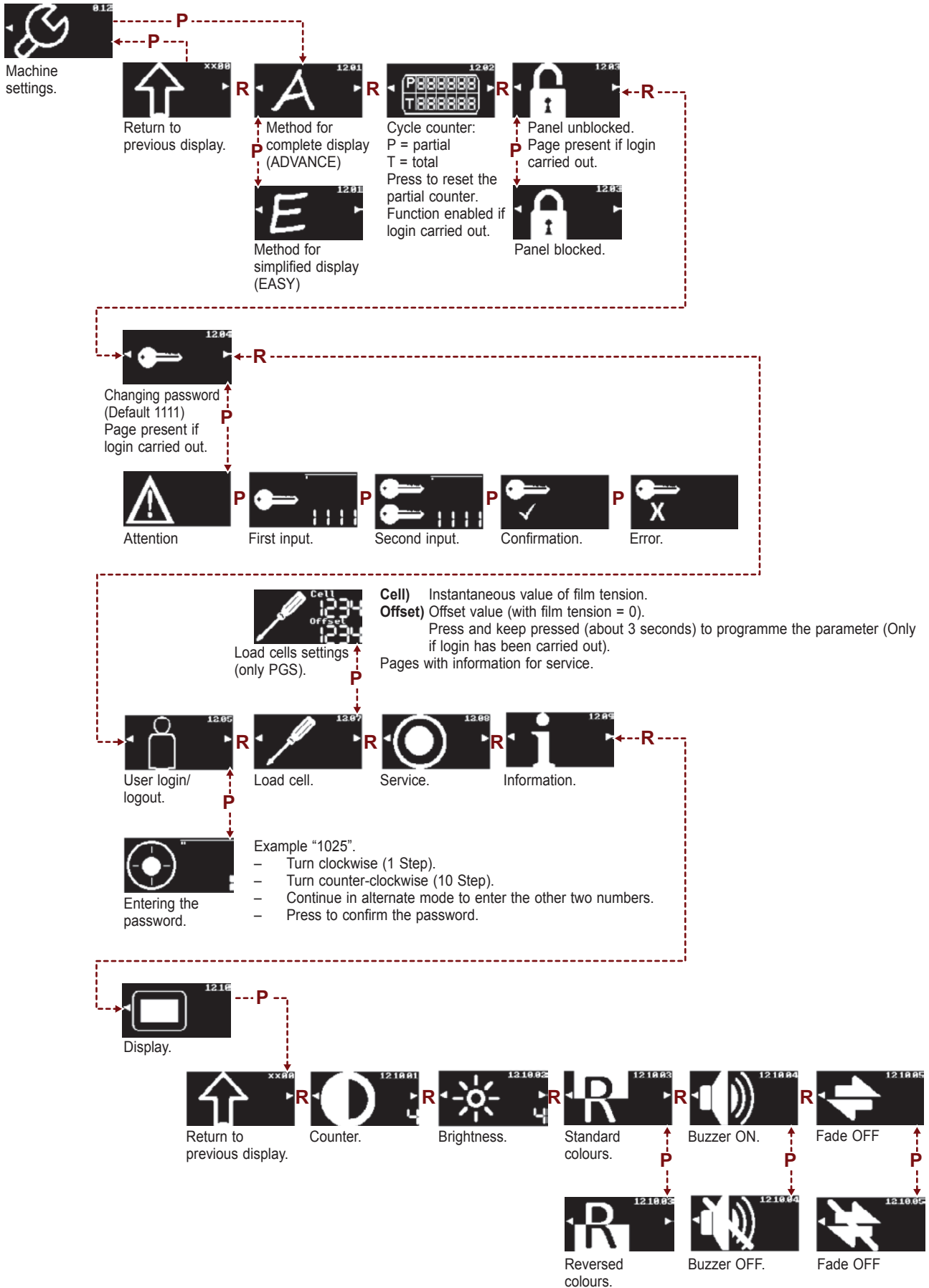

ABOUT THE USE

6.6. MANUAL CYCLE MENU

Before selecting the manual cycle set:

- Table rotational speed.
- Carriage speed
- Stretch.
- Presser present (See “Main menu”).



Start carriage ascent.

P



Start carriage descent.

P



Carriage stop.

To confirm the command selected press the start button **(C)**.

To end the operation, press the stop push-button **(D)**.

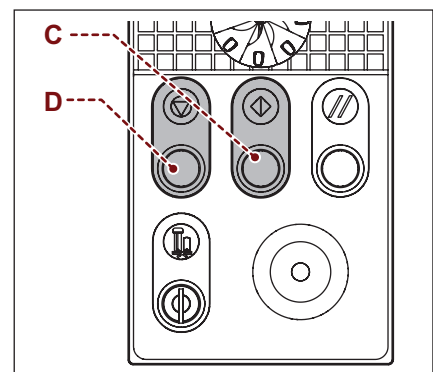

ABOUT THE USE

6.7. SELF-LEARNING CYCLE MENU

Time for single self-learning phase.

P



Self-learning phase number.

R



Saving control.
End of self-learning, the machining is saved to memory.

R



Start table rotation.

R



Start table rotation.

R



Stop table in reset position.

R



Start carriage ascent.

R



Start carriage descent.

R



Carriage stop.

To confirm the command selected press the start button (C).

To cancel the settings, press the stop push-button (D).

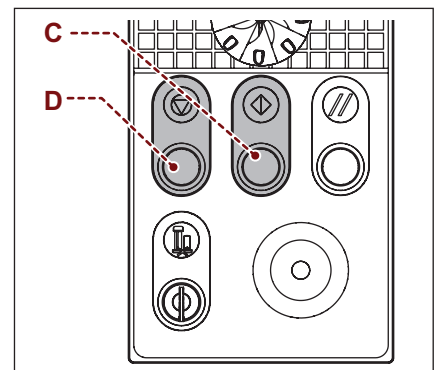

ABOUT THE USE

6.8. MENU DISPLAYED DURING THE STRAPPING CYCLE (WITH THE EXCLUSION OF THE MANUAL CYCLE)



Coating stretching.

P



R



Amount of intermediate strapping.

R

With each press of the jog the value that identifies the number of reinforcement rotations that will be applied to the product.



Plate rotation speed (rpm).

P



R



See "settings menu".

ABOUT THE USE

6.9. SIMPLIFIED DISPLAY MENU (EASY)

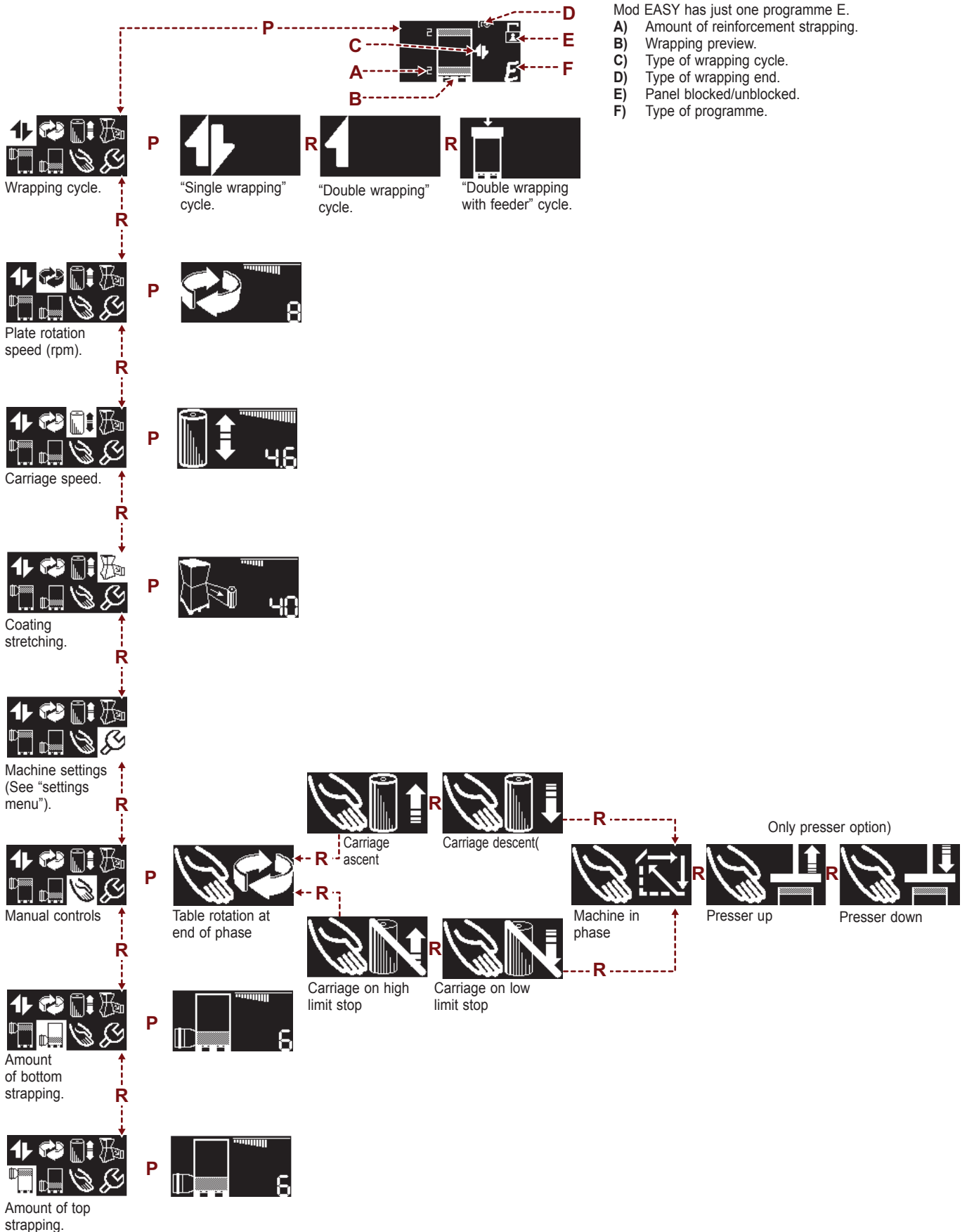

ABOUT THE USE

6.10. VARIOUS



Wrapping cycle in start phase.



Press the "Reset" button.



Press the "Cycle start" push-button.
Pick up from feeder cycle.



Emergency suspension.
Possibility of lifting the carriage (using the "start" button) also when there is an emergency carriage.

ABOUT THE USE

6.11. SWITCHING THE MACHINE ON AND OFF

Proceed as indicated.

1. Turn main switch **(A)** on **I (ON)** to turn on electric power supply. The icon to press the “reset” button appears on the display.
2. Press the “Reset” button **(B)**. The display shows the main page “Advance”.
3. For the “FREEZER” and “INOX” versions, activate the heating of the control panel using the selector **(C)**.

**Caution Warning**

With an ambient temperature less than 0°C, always start the heating of the control panel.

Switch off the heating of the control panel in case of prolonged use with ambient temperatures higher than 0°C.

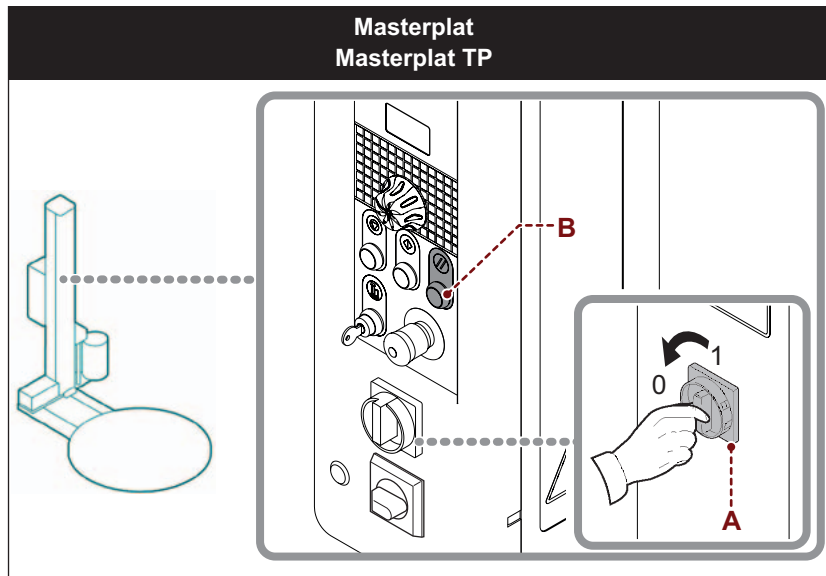

4. Set the cycle parameters (see 6.16. “Cycle parameter setting”).
5. Perform the cycle start operations (see 6.18. “Starting and stopping the cycle”).
6. Turn the main switch **(A)** to **0 (OFF)** to turn the machine off

6.12. CYCLE PARAMETER SETTING

Proceed as indicated

1. Switch the machine on (see 6.15. “Switching the machine on and off”).
2. Select the recipe by turning the jog.
3. Press the jog to select the recipe.
4. Turn to display and eventually change the parameters that have already been set for the recipe.
5. Press the jog to select the parameter and turn to change the value. This value will be memorised in the relative recipe.

ABOUT THE USE

6.13. WRAPPING CYCLES DESCRIPTION

Single wrapping cycle

To select the “single cycle”:

- Rotate the jog to enable the wrapping cycles page.
- Press the jog and select single wrapping.
- Press the jog to confirm.

The spool carriage starts from the bottom of the pallet and stops at the top after having accomplished the preset number of rounds at the bottom and top of the pallet.

(See 6.3. “Description of user interface”).

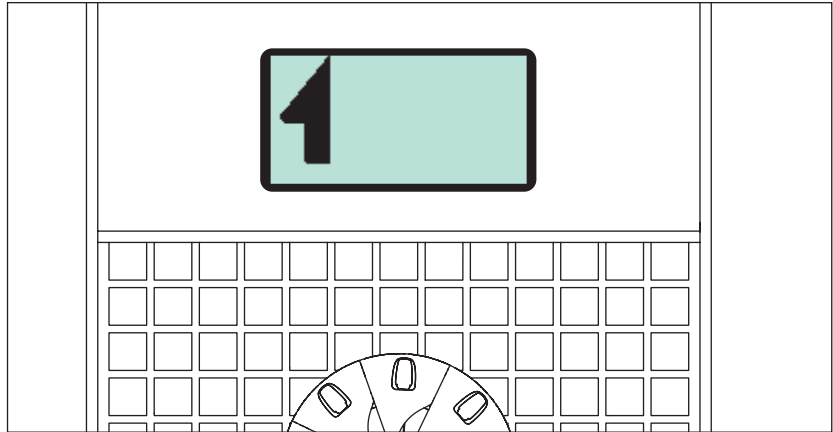

Double wrapping cycle

To select the “double cycle”:

- Rotate the jog to enable the wrapping cycles page.
- Press the jog and select double wrapping.
- Press the jog to confirm.

The reel carriage moves off from the bottom of the pallet and stops when it gets to the top, and then comes back down to the bottom of the pallet again, wrapping the load twice in doing so.

(See 6.3. “Description of user interface”).

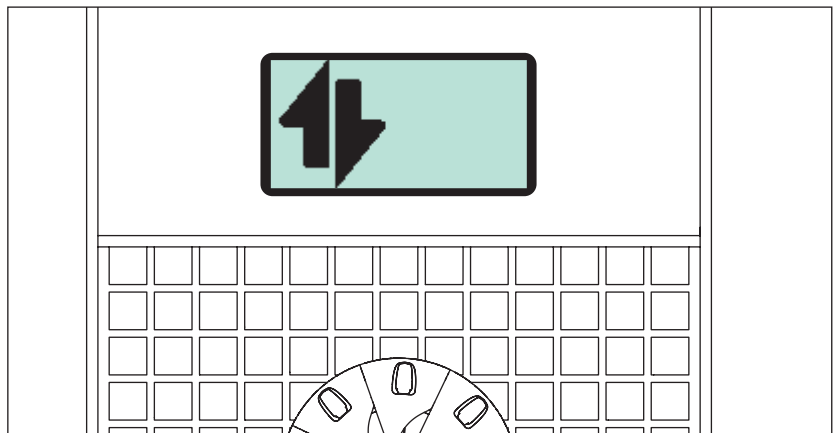

ABOUT THE USE

Wrapping cycle with feeder

To select the cycle.

- Rotate the jog to enable the wrapping cycles page.
- Press the jog and select wrapping with feeder.
- Press the jog to confirm.

The machine performs a cycle which is aimed at facilitating the coverage of the pallet by the operator, and which guarantees the highest degree of protection possible.

The reel carriage rises to the top of the load and then lowers by about 300 mm stopping in this position.

If the machine is fitted with a top pressure platen, this lifts from the load by about 200 mm.

At this point, the operator, after having positioned the covering sheet on the top of the pallet, reactivates the cycle by pressing the "Start" button; the presser descends once more

The carriage rises again until it reaches the top of the pallet, performs the set number of upper wrappings of the pallet, then descends once more, thus completing the cycle

In this way, the position of the covering sheet, bound as it is by the upwards and downwards spirals of film, guarantees excellent protection of the load against atmospheric agents (water, dust, etc)

(See 6.3. "Description of user interface").

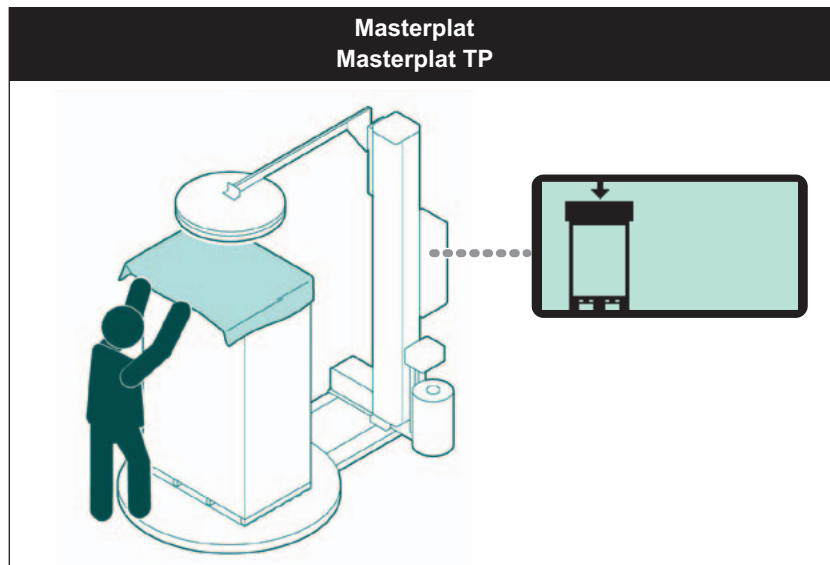

ABOUT THE USE

6.14. STARTING AND STOPPING THE CYCLE

Proceed as indicated.

1. Place the load on turntable and set aside the loading device.
2. Lock the end of the film to the bench.
3. Set the desired wrapping mode.
For further details consult the paragraph "Description of the user interface".

**Caution Warning**

Do not over stretch or pre-stretch the film and do not wrap with an excessive number of bindings in order to prevent damaging the packages and products contained inside.

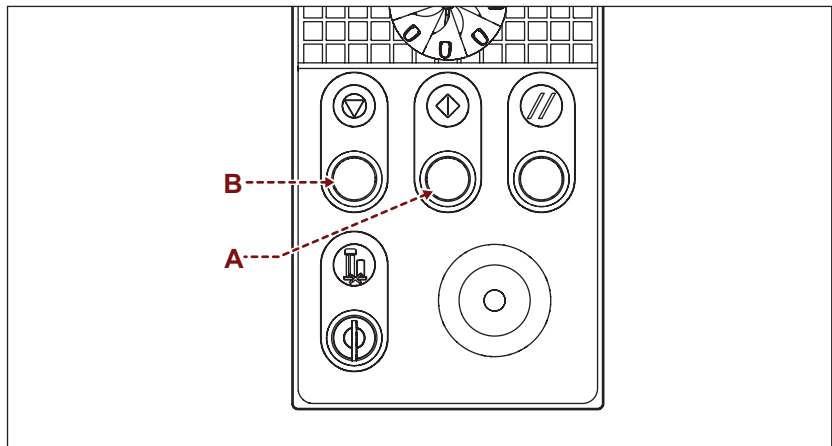

4. Press the "Cycle start" push-button **(A)**.
The machine performs a cycle and stops automatically.
5. Proceed to film cutting.
6. Remove the load and place another one on the table to start a new cycle.

**Important**

**To pause the cycle, press the "Stop cycle" (B) button.
Press the "start cycle" button (A) to restart.**

Information applicable only to the wrapping mode "Sheet Feeder Cycle"

- When the machine stops at the upper part of the pallet, put the TOP sheet in place (do not cut the film at this stage).
- Press the "Cycle start" push-button **(A)**.
The machine then resumes the wrapping process and stops at the base of the pallet upon completion of the programmed cycle.

ABOUT THE USE

6.15. CHANGE THE PRESSER HEIGHT

- The presser assembly can be supplied in the version with pneumatic cylinder (stroke 800) or mechanical cylinder
- The illustrations show the machine with the presser assembly in the versions available.
- Refer to the tables to identify the minimum height of the pallet to be wrapped depending on the version of the presser assembly installed on the machine.

Rod pneumatic cylinder

1. Loosen the screw (A).
2. Adjust the height of the pneumatic cylinder (B) on the guide (C) according to the size of the product to be wrapped.
3. Tighten the screw (A).

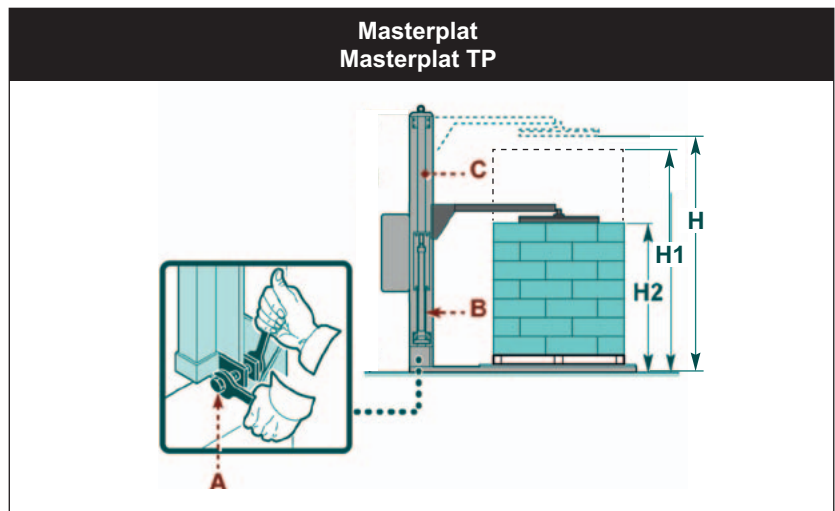

Table 6.4.: Height of presser (Rod pneumatic cylinder).

Presser assembly version	Slide guide mast	Arm in Normal position	
	H (mm)	H1 (mm)	H2 (mm)
Rod pneumatic cylinder	2350	2200	1400
	2550	2400	1400
	2950	2800	1400
	3250	3100	1400

ABOUT THE USE

6.16. REEL LOADING

Proceed as indicated.

1. Insert film reel in the proper housing on the reel carriage.
2. Gather the film and form a thin cord, then insert it between the double-cone surfaces.

 Important

Unwind the film according to the procedure shown on the label applied on the roll-holder carriage plate.

3. Pull the cord outwards.
The film will automatically drop on the roller and cover it all along its height.
4. Block the edge of the film in the clasp disk **(A)** on the rotating table.

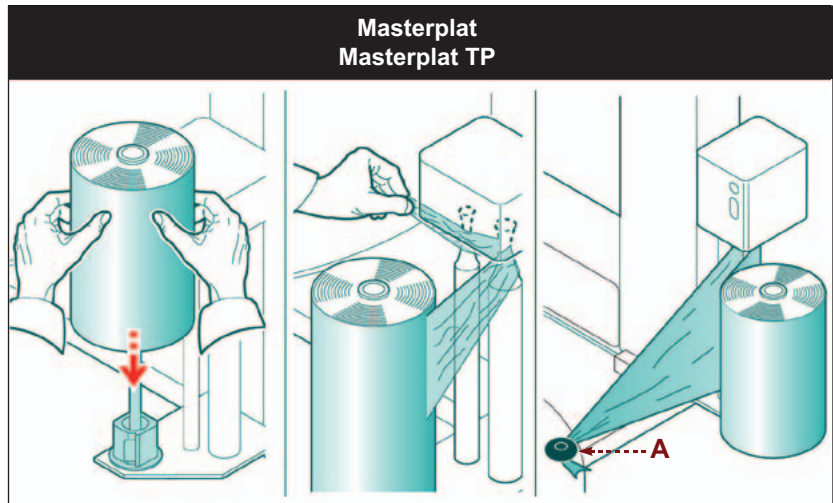

- On reel carriage type “FRD”, to insert film or net between the rollers and its unwinding, it is necessary to release the brake by rotating hand wheel **(B)** in position “0”.

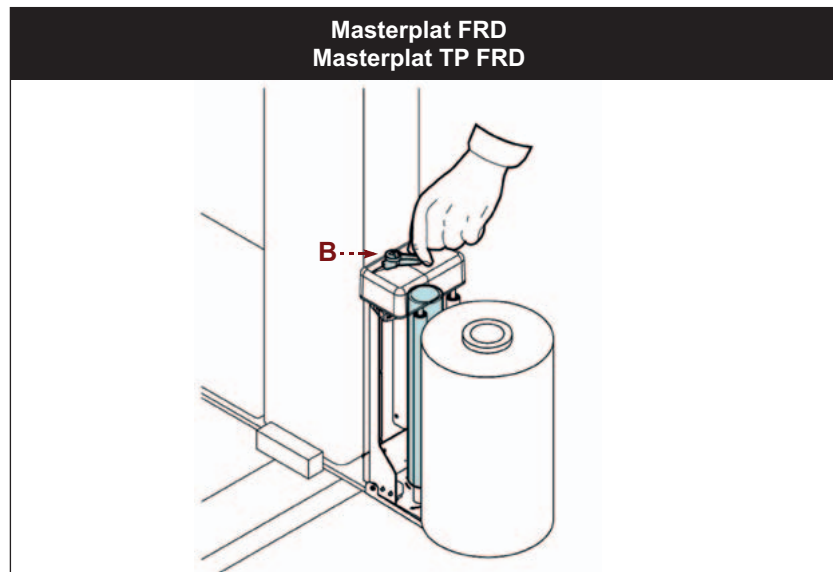

- On reel carriages type “PGS”, to allow film unwinding, it is necessary to press the roller rotation button **(C)** on the reel carriage.

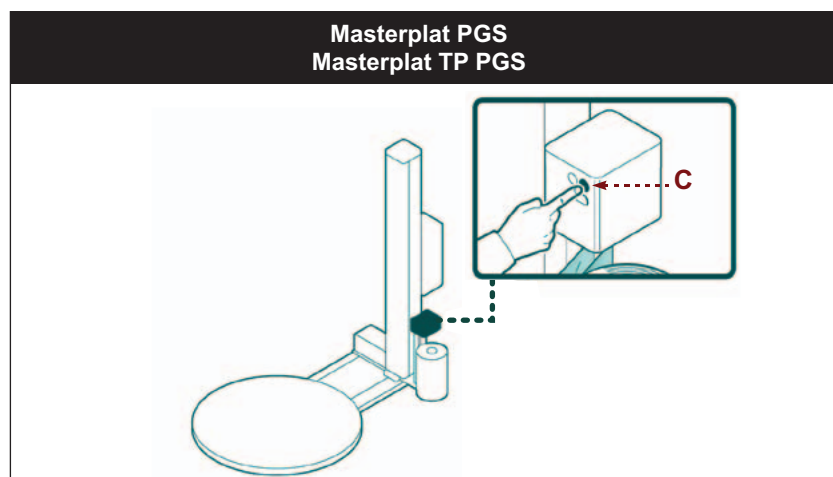

MAINTENANCE INFORMATION

7.1. MAINTENANCE INSTRUCTIONS

- A good maintenance will allow for a longer working life and constant compliance with the safety requirements.
- Before performing any operation, the authorised operator must make sure that he/she understood the “Instructions for use”.
- Pay attention to the **SAFETY WARNINGS**, do not use the machine for **UNSPECIFIED PURPOSES** and assess the possible **RESIDUAL RISKS**.
- Carry out the interventions with all the safety devices enabled and wear the DPI provided.
- Mark the intervention area and prevent access to the devices that, if activated, may cause unexpected hazards and jeopardize the safety level.
- **DO NOT** carry out any intervention that is not described in the manual but contact an Assistance Service authorised by the manufacturer.
- **DO NOT** dump in the environment materials, pollutant liquids and the residues created during the interventions but dispose them according to the standards in force.
- Before carrying out any maintenance work, turn off the electric and pneumatic power supply.

MAINTENANCE INFORMATION

7.2. MAINTENANCE PERIOD TABLE

 Important

Keep the machinery in maximum efficiency condition and perform all the scheduled maintenance operations provided for by the manufacturer.

Proper maintenance will provide the best performance, a longer life span and constant compliance with safety requirements

Table 7.1.: Maintenance period

Frequency	Component	Type of intervention	Procedure	Reference
Every 40 hours	Machine	Cleanliness.	Clean with a cloth of air jet.	-
	Air filtering unit	Condensate discharge.	-	See 7.5. "Condensate drainage".
		Cleaning the filter.	Clean with a blast of air and alcohol.	See 7.6. "Cleaning the air filter".
Every 200 hours	Rubber coated rollers	Cleanliness.	Clean with alcohol.	-
	Lifting chains	Greasing.	-	See 7.3. "Lubrication point diagram".
		Tensioning check.	Adjust.	See 5.3. "Reel carriage lifting chain adjustment".
	Table rotation chain	Greasing.	-	See 7.3. "Lubrication point diagram".
		Tensioning check	Adjust.	See 5.4. "Table rotation chain adjustment".
	Reduction gears and gearmotors	Lubricant level check ⁽¹⁾ .	Top-up with a lubricant of the same kind if necessary.	See 7.4. "Lubricants table".
Toothed wheels of the carriage drawing gears	Greasing.	-	See 7.3. "Lubrication point diagram".	
Every 2000 hours	Lifting chains	Wear check	-	-
	Safety devices	Efficiency control	-	-
	Table rotation chain	Wear check.	-	-
Every 5000 hours	Revolving table wheels	Replacement.	-	See 9.2. "Replacing rotating table wheels".
	Carriage lifting wheels	Replacement.	-	-
	Reduction gears and gearmotors	Replacing the lubricant ⁽¹⁾	Use lubricants with the same characteristics.	See 7.4. "Lubricants table".
Non-routine maintenance				
Every 5 years (Masterplat TP)	Reset button	Replacement.	Replace.	-

⁽¹⁾ The reduction gears and gearmotors may be lubricated with either grease, oil, or for life.

Reduction gears and gearmotors that are lubricated for life do not need to be topped up and/or replaced.

MAINTENANCE INFORMATION

7.3. LUBRICATION POINT DIAGRAM

The following diagram shows the main components and the frequency of the lubrication interventions.

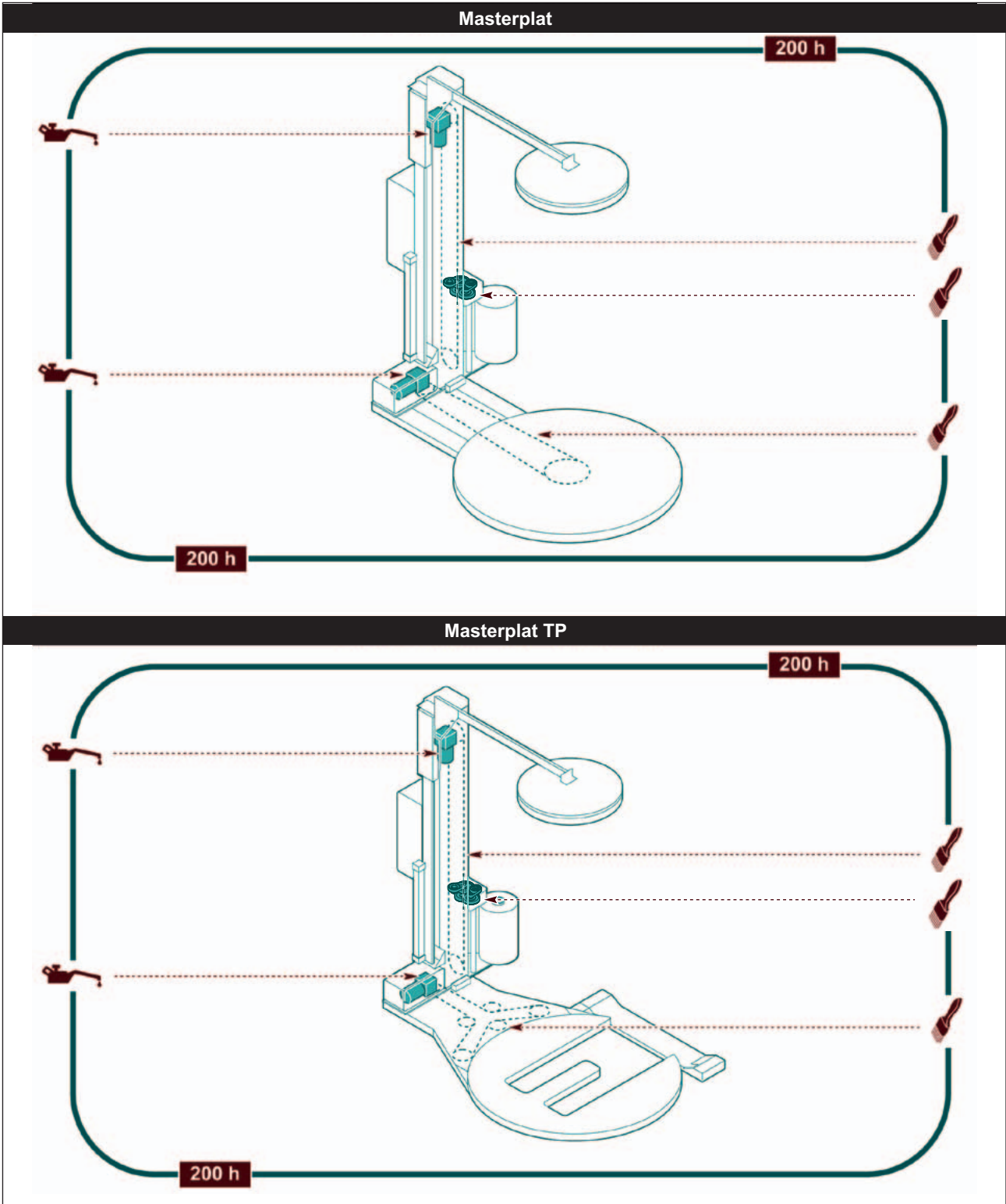

Symbol and Description

	Smear with grease.		Check lubricant level. Do not top-up and/or replace the lubricant in reduction gears and gearmotors lubricated for life.
---	--------------------	---	---

MAINTENANCE INFORMATION

Keep to the recommended lubrication frequency to get top machine performances and a longer operating life.

Use lubricants (oils or grease) recommended by the manufacturer or with similar chemical-physical features.

MAINTENANCE INFORMATION

7.4. LUBRICANTS TABLE**Table 7.2.:** Lubricant specifications:
Masterplat - Masterplat TP - Masterplat INOX.

Type of lubricant	Name	Parts to be lubricated
Mineral oil	23°C a 50°C - 320 CST a 40°C	Gear motor
	MELLANA OIL 320 IP	
	SPARTAN EP 320 ESSO	
	BLASIA 320 AGIP	
	MOBILGEAR 632 MOBIL	
	OMALA EP 320 SHELL	
	ENERGOL GR-XP 320 BP	
	32°C a 50°C - 460 CST a 40°C	Worm gear motor
	MELLANA OIL 460 IP	
	SPARTAN EP 460 ESSO	
	BLASIA 460 AGIP	
	MOBILGEAR 634 MOBIL	
	OMALA EP 460 SHELL	
	ENERGOL GR-XP 460 BP	
Grease	TELESIA COMPOUND B IP	Gear and worm gear motor
	STRUCTOVIS P LIQUID KLUBER	
	TOTALCARTER SYOO TOTAL	
Synthetic oil	TELESIA OIL IP	
	SYNTHESO D 220 EP KLUBER	
	BLASIA S 220 AGIP	
Lithium grease	ALVANIA R2 SHELL	Bearings with support
	HL 2 ARAL	
	ENERGREASE LS2 BP	
	BEACON 2 ESSO	
	MOBILIX MOBIL	
Synthetic oil	-5°C / +5°C VG 68 (SAE 20)	Reel carriage lifting chain
	+5°C / +25°C VG 100 (SAE 30)	Table rotation chain
	+25°C / +45°C VG 150 (SAE 40)	
	+45°C / +70°C VG 220 (SAE 50)	

 Important**Do not mix oils of different makes and specifications.****Table 7.3.:** Lubricant specifications for low temperature:
Masterplat FREEZER - Masterplat INOX

Type of lubricant	Name	Parts to be lubricated
Grease	KG1 POLILUB WH 2 POLIVALENTE KLUBER	Bearings with support
Oil	KLUBEROIL-4-UH1-68 KLUBER	Reel carriage lifting chain Table rotation chain

 Important**Do not mix oils of different makes and specifications.**

MAINTENANCE INFORMATION

7.5. CONDENSATE DISCHARGE

Proceed as indicated.

1. Close the tap (A) and control the level of condensation in the container (B).
2. Unscrew, if necessary, the valve (C) to empty condensation.
3. Push the valve (C) up until all condensation is removed.
4. Tighten the valve (C).

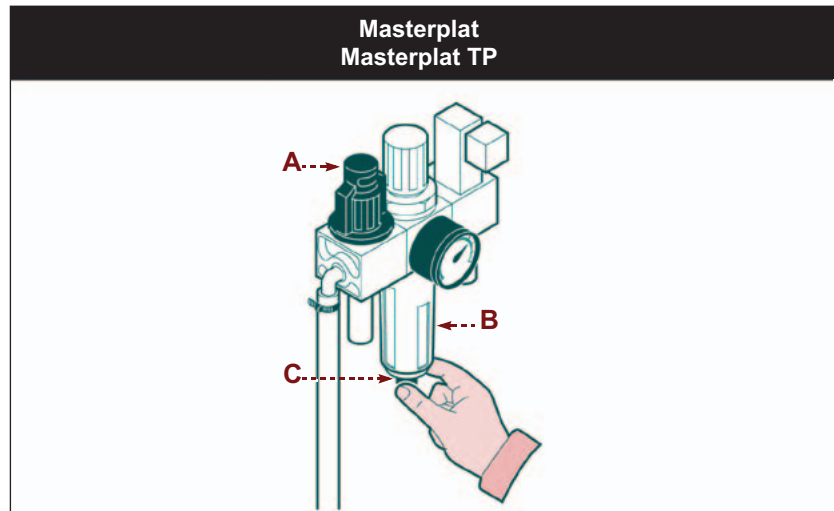

7.6. CLEANING THE AIR FILTER

Proceed as indicated.

1. Unscrew the container (B) with the wrench.
2. Detach the filter and clean with compressed air and wash, if necessary with petrol or trichloroethylene.
3. Reassemble the filter and tighten the container (B).

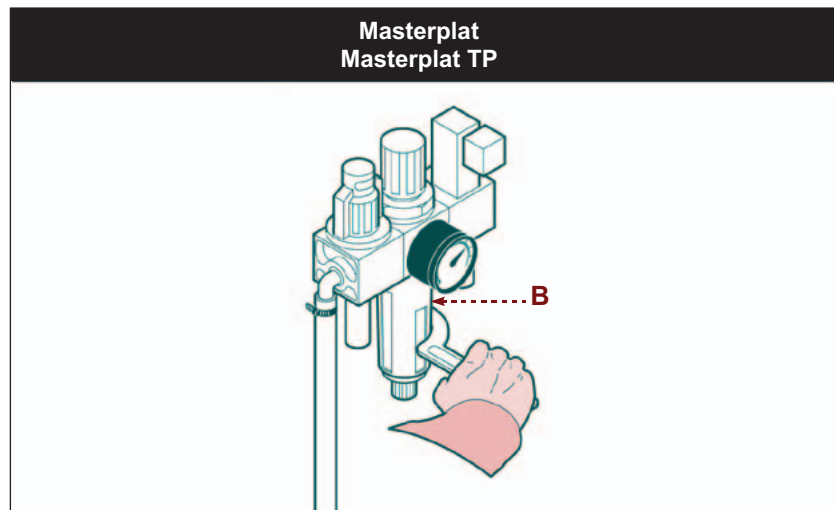

TROUBLESHOOTING

8.1. ALARM MESSAGES







In the event of a breakdown during operations the machine stops automatically and alarm messages appear on the display.

The table lists the displayed messages, the type of problem, the cause and possible solutions.

 **Important**

For these operations a precise technical skill or ability is required; therefore, these operations must be exclusively performed by qualified personnel with certified experience acquired in the specific field.

Table 8.1.: Alarms List

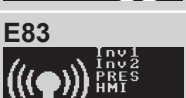
Name	Problem	Cause	Remedy
E01 	Emergency stop push button	Emergency alarm mushroom button pressed	Reset, by turning the button in the direction indicated by the arrow, and press Reset.
E02 	Carriage emergency	An obstacle has been detected along the descent path of the reel carriage.	Remove the obstacle and press the "Reset" button.
E03 	Transpallet emergency	An obstacle has been detected on the platform loading/unloading ramp.	Remove the obstacle and press the "Reset" button.
E30 	Fault Inverter overload: 1 Worktable. 2 Trolley. 3 Pull.	Motor fault.	Contact the Servicing Dept.
E60 	"Film rupture" alarm	The film has broken or reel is empty.	Insert the film or replace reel.
E61 	Table phase alarm	A breakdown or obstacle block table rotation.	Fix the breakdown or remove the obstacle and press the "Reset" button.
E83 	Communication error alarm	Electronic fault.	Contact the Servicing Dept.

SPARE PARTS REPLACEMENT INFORMATION

9.1. RECOMMENDATIONS FOR REPLACING PARTS

- Before performing any operation, the authorised operator must make sure that he/she understood the “Instructions for use”.
- Carry out the interventions with all the safety devices enabled and wear the DPI provided.
- Delimitate the work area complying with the safety conditions as provided by the standards on workplace safety in order to minimise the risks.
- **DO NOT** carry out any intervention that is not described in the manual but contact an Assistance Service authorised by the manufacturer.
- **DO NOT** dump in the environment materials, pollutant liquids and the residues created during the interventions but dispose them according to the standards in force.
- Replace the components **ONLY** with **ORIGINAL PARE PARTS** or with **SIMILAR** design and functional features.
The use of similar but non-original spare parts may lead to improper repairs, altered performance and economic damage.
- The components and/or safety devices shall be replaces **ONLY** with original spare parts to avoid altering the provided safety level.

SPARE PARTS REPLACEMENT INFORMATION

9.2. REPLACING ROTATING TABLE WHEELS

Proceed as indicated.

1. Loosen the screws (**A**).
2. Assemble the eyebolts (**B**) on the rotating table (**C**).
3. Lift the table and place it on the floor.
4. Replace the wheels (**D**).
5. Position the table on the base and fasten it with the screws.

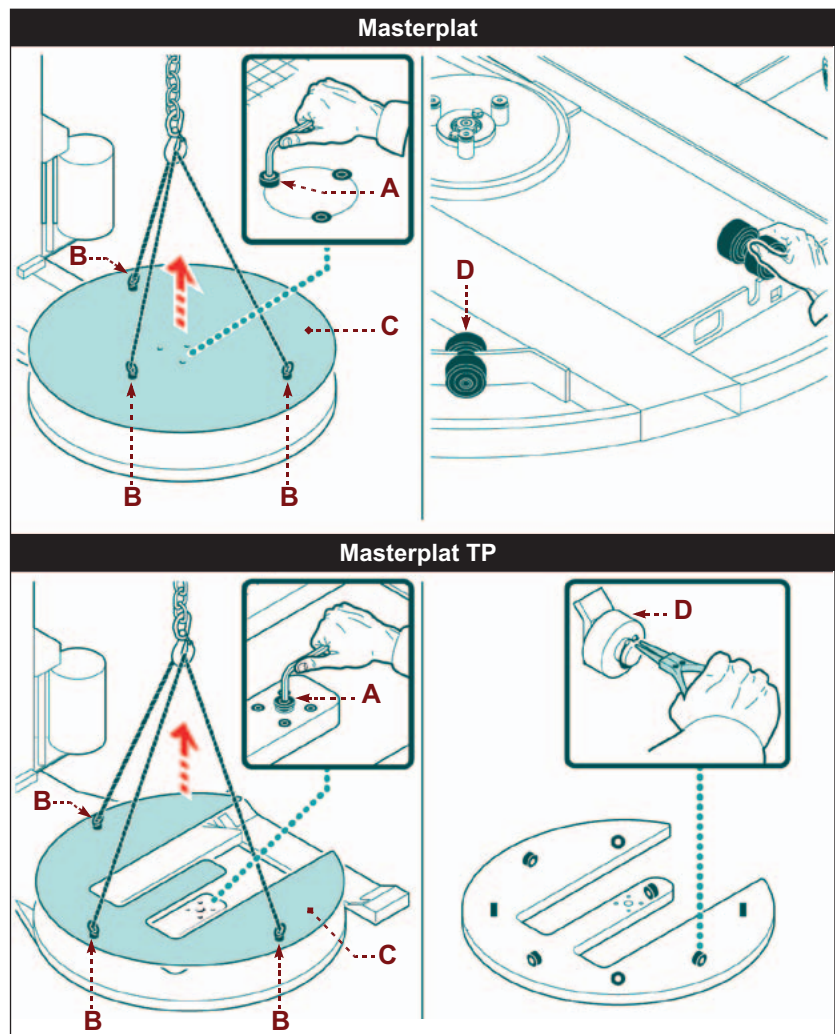

SPARE PARTS REPLACEMENT INFORMATION

9.3. LIST OF THE RECOMMENDED SPARE PARTS

List of the spare parts of easy wear and of which it would be necessary to have available to avoid long operation stops of the machine.

For ordering, contact your local Dealer and refer to the spare parts catalogue.

- no. 14 double wheels for the base.
- no. 8 Carriage support wheels.
- no. 1 Roll brake pad.
(Only for spool carriages type “FRD”).
- no. 1 Drive belt.
(Only for spool carriages type “PGS”).



Important

Substitute the parts that are worn with genuine spare parts.

Use the oils and greases specified in the manual.

All these measures may guarantee the expected operating and safety level of the machine.

9.4. MACHINE DISPOSAL AND SCRAPING

Taking the machinery out of service

- Disconnect the supplies to the machine (electrical, pneumatic, etc...) so that it cannot be restarted and position it in a place not easy to access.
- Empty in an adequate way the systems containing damaging substances and do it in accordance with the current laws in force at workplaces and those regulating environmental protection.

Machine scrapping

- Scrapping must be entrusted to authorized centres having the adequate skills and equipment to operate in safety conditions.
- Those who carry out the scrapping must locate the possible residual energies and implement a “safety plan” with the purpose of eliminating unexpected residual risks.
- The components must be selected depending on the chemical and physical characteristics of the materials and disposed of in a differentiated way, as per current regulations.
- Empty in an adequate way the systems containing damaging substances and do it in accordance with the current laws in force at workplaces and those regulating environmental protection.

ENCLOSED DOCUMENTATION

10.1. WARRANTY CONDITIONS

ROBOPAC S.p.A. pledges, within the limits described herein, to replace or repair, at no charge, the parts that become defective during the 12 (twelve) months following the date indicated on the company's shipping documents.

To utilise the warranty, the user must immediately notify the company that a defect exists, always referring to the machine serial number.

ROBOPAC S.p.A., in its final judgement, will decide whether to replace the defective part or request it to be shipped for tests and/or repairs.

By replacing or repairing the defective part, ROBOPAC S.p.A. fully complies with its warranty obligations and will be released from all liabilities and obligations relative to transport, travel and hotel expenses for technicians and installers.

ROBOPAC S.p.A. will never be held responsible for any losses due to lack of production or injuries to persons or damage to things caused by malfunctions or forced suspension in using the machine covered by the warranty.

The warranty does not cover:

- damage caused by transport;
- damage due to incorrect installation;
- improper use of the machine or negligence;
- tampering or repairs by unauthorised personnel;
- lack of maintenance;
- parts subject to normal wear and tear.

For purchased components and parts, ROBOPAC S.p.A. offers the user the same warranty conditions that the company obtains from the suppliers of the aforementioned components and/or parts.

ROBOPAC S.p.A. does not guarantee the conformity of machines to current standards in countries that are not part of the European Union.

Concerning any adjustments to standards of the country in which the machine is installed, the user will be fully responsible for the changes made, releasing ROBOPAC S.p.A. from any obligation and /or liability relative to any claims that may be submitted by third parties due to non-compliance with the referenced standards.

10.2. PRESSURE PLATEN PNEUMATIC DIAGRAM

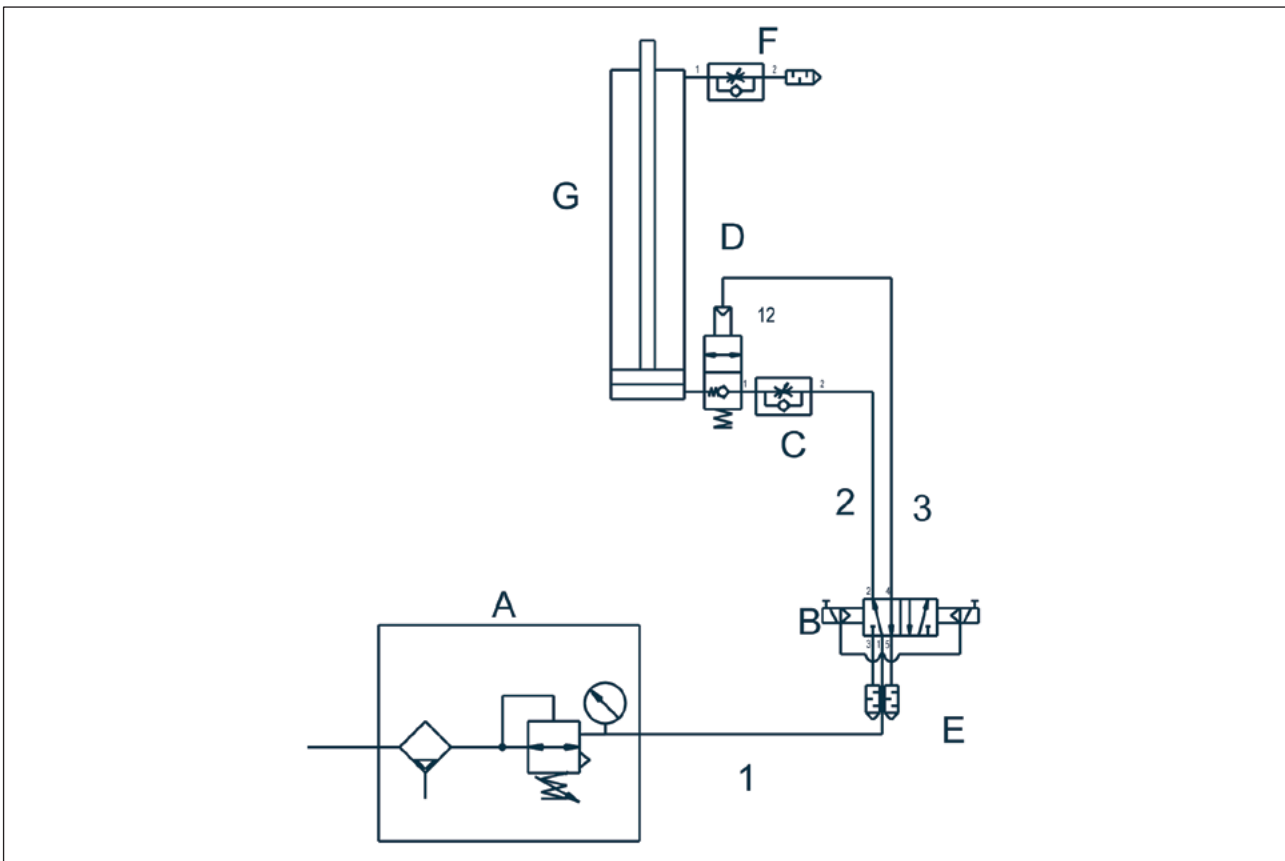

Key

- A Filter/regulator unit
- B Solenoid valve
- C Flow regulator
- D Silencer
- E Discharge solenoid valve
- F Presser drive pneumatic cylinder