



Via Fabrizio da Montebello, 81
 47892 Gualdicciolo
 Tel +378 0549 910511 Fax +378 0549 908549
 Repubblica di San Marino

Modello Macchina
 Machine Model
 Maschine Modell
 Modele de la Machine
 Modelo Maquina

Masterplat Pgs UL-CSA

Numero Matricola
 Machine Serial Number
 Maschine Kennnummer
 Numero de Matricule
 Numero de Matricula

Tensione di alimentazione
 Power Supply Voltage
 Spannungsversorgung
 Voltage electrique
 Tension de Alimentacion

60 Hz

1 Ph + N

Potenza Installata
 Installed Power
 Installierte Leistung
 Puissance installée
 Potencia Instalada

2.1 kW

Corrente Assorbita
 Absorbed Current
 Stromaufnahme
 Absorption Electrique
 Absorcion

See table **A**
 pag.4

For Robopac Use Only

Codice Quadro Elettrico

7450305687R5013B

Indice Modifica

R0

Numero Bolla

02193

Costruire secondo specifica tecnica 50.1.1
 Controllare con scheda di collaudo

PGS UL_7450305687

Elaborato da

Brizi A.

Verificato da

Ingrosso D.

Approvato da

Laghi P.



Description

**Copertina
 Cover sheet**

Code

3709303614

Date

11/12/2017

Total

28

Prev

Subs

2

Page

1

Machine

Masterplat Pgs UL-CSA

Sommario delle pagine

Table of contents

Impianto Higher-level function	Luogo di montaggio Mounting location	Pagina Page	Descrizione pagina Page description	Campo aggiuntivo delle pagine supplementary page field	Data Date	Elaboratore Edited by
		1	Copertina Cover sheet		11/12/2017	abrizi
		2	Sommario delle pagine : /1 - /90 Table of contents : /1 - /90		14/12/2017	abrizi
		2.1	Sommario delle pagine : /100 - /124 Table of contents : /100 - /124		14/12/2017	abrizi
		4	Targhetta quadro elettrico Plate control cabinet		11/12/2017	abrizi
		5	Distinta articoli Parts list		11/12/2017	abrizi
		5.1	Distinta articoli Parts list		14/12/2017	abrizi
		9	Legenda simboli Symbols legend		11/12/2017	abrizi
		10	Alimentazione Power supply		11/12/2017	abrizi
		20	Circuito di potenza Power circuit		11/12/2017	abrizi
		30	Circuito di potenza Power circuit		11/12/2017	abrizi
		40	Circuito Ausiliario Auxiliary Circuit		11/12/2017	abrizi
		50	Circuito emergenza Emergency circuit		11/12/2017	abrizi
		60	Circuito Ausiliario Auxiliary Circuit		11/12/2017	abrizi
		70	Circuito Ausiliario Auxiliary Circuit		11/12/2017	abrizi
		80	Circuito Ausiliario Auxiliary Circuit		11/12/2017	abrizi
		90	Circuito Ausiliario Auxiliary Circuit		11/12/2017	abrizi

Sommario delle pagine

Table of contents

Impianto Higher-level function	Luogo di montaggio Mounting location	Pagina Page	Descrizione pagina Page description	Campo aggiuntivo delle pagine supplementary page field	Data Date	Elaboratore Edited by
		100	Circuito Ausiliario Auxiliary Circuit		14/12/2017	abrizi
		110	Layout		11/12/2017	abrizi
		115	Plc, Inverter		11/12/2017	abrizi
		116	Sommario cavi Cable overview		11/12/2017	abrizi
		117	Morsettiera alimentazione Power supply terminalboard		11/12/2017	abrizi
		118	Morsettiera potenza Power terminalboard		11/12/2017	abrizi
		119	Morsettiera ausiliari Aux Terminal strip		11/12/2017	abrizi
		120	Morsettiera modbus Modbus terminalboard		11/12/2017	abrizi
		121	Connettore basamento Base Connector		11/12/2017	abrizi
		122	Connettore basamento Base Connector		11/12/2017	abrizi
		123	Connettore scheda prestiro Prestretch card connector		11/12/2017	abrizi
		124	Connettore scheda prestiro Prestretch card connector		11/12/2017	abrizi



Description

Sommario delle pagine : /100 - /124
Table of contents : /100 - /124

Code

3709303614

Date

11/12/2017

Total

28

Prev

2

Subs

4

Page

2.1

Machine

Masterplat Pgs UL-CSA

ROBOPAC		
Tension Voltage	110 V	120 V
Phase, Frequency Phase, Frequence	Single phase, 60Hz	
Total FLA	10.2 A	9,4 A
Largest motor FLA Plus grand moteur FLA	2,2 A	
Largest Heater load FLA Plus grand FLA de charge de chauffage	/////	
SCCR	5 kA	
Enclosure Type Type de châssis	TYPE 1	
Field Wiring Diagram Schema électrique	3709303614	

Fuse	V	A	Type
F0	600 VAC	10	CLASS CC - TIME DELAY
F1	600 VAC	8	CLASS CC - TIME DELAY
F2	600 VAC	8	CLASS CC - TIME DELAY
F3	600 VAC	1	CLASS CC - TIME DELAY
F4	600 VAC	4	CLASS CC - TIME DELAY



Description

Targhetta quadro elettrico
Plate control cabinet

Code 3709303614

Date 11/12/2017

Total 28

Prev 2.1

Subs 5

Page

4

Machine Masterplat Pgs UL-CSA

Distinta articoli

Parts list

F01_ART_0000

SEF	Designazione Designation	Numero tipo Type number	Produttore Manufacturer	Quantità Quantity	Codice Code	Pagina Page
-BOX	Cassetta elettrica Electric box		Robopac	1	4280300229R5013B	/10.0
-BOX	Pannello cassetta elettrica Electric box panel		Robopac	1	5210300452R7040B	/10.0
-X0	morsetto passante per 2 conduttori 2-CONDUCTOR THROUGH TERMINAL BLOCK	2004-1201	WAGO	2	00L0074305G	/10.0
-X0	morsetto per conduttore di protezione per 2 conduttori 2-CONDUCTOR EARTH TERMINAL BLOCK	2004-1207	WAGO	1	00L0074306L	/10.0
-V1	Filtro alimentazione Main filter	10SS4-2DC2-Q (10S42EC2)	Comestero Sistemi	1	00L0428417	/10.1
-F0	Fusibile cilindrico 10,3X38 RIT 10A 600V CC UL/CSA Cylindrical Fuse 10,3x38 10A 600V CC UL/CSA	10,3x38 RIT 10A 600V CC UL/CSA		1	0001304313D	/10.1
-F0	Base per fusibile 10 X 38 1P UL/CSA Base for fuse 10 X 38 1P UL/CSA	USBCC1	Ferraz Shawmut	1	00L0139112E	/10.1
-T0	Autotrasformatore 2500VA 110/120/240V	OAM0640801051	Italweber Elettra	1	00L0419327	/10.1
-Q1	Sezionatore 750V 125A 3P Switch-disconnector 750V 125A 3P	OT125FT3	ABB	1	0001310772E	/10.1
-Q1	Maniglia retroquadro GRI-NER Handle for door mounted GY-BK	OHBS2RJ	ABB	1	0001310774	/10.1
-X00	Spina Plug	5965-VBLK	Hubbell	1	0001353540E	/10.1
-T1	Inverter Variable speed drives	INV01ROB_2	Robopac	1	1430300271	/20.1
-F1	Fusibile cilindrico 10,3X38 RIT 8A 600V CC UL/CSA Cylindrical Fuse 10,3x38 8A 600V CC UL/CSA	10,3x38 RIT 8A 600V CC UL/CSA		1	0001304312B	/20.2
-F1	Base per fusibile 10 X 38 1P UL/CSA Base for fuse 10 X 38 1P UL/CSA	USBCC1	Ferraz Shawmut	1	00L0139112E	/20.2
-S5	Selettori a chiave, 2 posizioni, ad impulso Selector switch actuator, 2 Pos., spring-return	M22-WS	Eaton Moeller	1	0001300015G	/20.4
-S5	Supporto per contatti Fixing adapter	M22-A	Eaton Moeller	1	0001300700A	/20.4
-S5	Elementi di contatto, 1NA, Fissaggio frontale, Cage clamp Contact element, 1N/O, Front fixing, Cage clamp	M22-CK10	Eaton Moeller	1	0001300024F	/20.4
-S5	Elementi di contatto, 1NC, Fissaggio frontale, Cage clamp Contact element, 1N/C, Front fixing, Cage clamp	M22-CK01	Eaton Moeller	2	0001300027C	/20.4
-T2	Inverter Variable speed drives	INV01ROB_2	Robopac	1	1430300271	/30.1
-F2	Fusibile cilindrico 10,3X38 RIT 8A 600V CC UL/CSA Cylindrical Fuse 10,3x38 8A 600V CC UL/CSA	10,3x38 RIT 8A 600V CC UL/CSA		1	0001304312B	/30.2
-F2	Base per fusibile 10 X 38 1P UL/CSA Base for fuse 10 X 38 1P UL/CSA	USBCC1	Ferraz Shawmut	1	00L0139112E	/30.2
-U1	Logica Programmabile PLC	PLC02ROB	Robopac	1	1430300228	/40.1
-F3	Fusibile cilindrico 10,3X38 RIT 1A 600V CC UL/CSA Cylindrical Fuse 10,3x38 1A 600V CC UL/CSA	10,3x38 RIT 1A 600V CC UL/CSA		1	0001304300F	/40.1
-F3	Base per fusibile 10 X 38 1P UL/CSA Base for fuse 10 X 38 1P UL/CSA	USBCC1	Ferraz Shawmut	1	00L0139112E	/40.1
-U3	Display	DIS03ROB_1	Robopac	1	7450305535GREZZO	/40.2
-U4	Scheda Card	RJ_01ENC	Robopac	1	1430300125	/40.7
-U8	Modulo di sicurezza Safety relay	CS-AT-10V024-TF1	Pizzato	1	1400300008	/50.1
-S2	Pulsante, piatto, blu, ad impulso Pushbutton actuator, flush, blue, spring return	M22-D-B	Eaton Moeller	1	0001300696B	/50.5
-S2	Supporto per contatti Fixing adapter	M22-A	Eaton Moeller	1	0001300700A	/50.5
-S2	Elementi di contatto, 1NA, Fissaggio frontale, Cage clamp Contact element, 1N/O, Front fixing, Cage clamp	M22-CK10	Eaton Moeller	2	0001300024F	/50.5
-F4	Fusibile cilindrico 10,3X38 RIT 4A 600V CC UL/CSA Cylindrical Fuse 10,3x38 4A 600V CC UL/CSA	10,3x38 RIT 4A 600V CC UL/CSA		1	0001304307B	/60.0
-F4	Base per fusibile 10 X 38 1P UL/CSA Base for fuse 10 X 38 1P UL/CSA	USBCC1	Ferraz Shawmut	1	00L0139112E	/60.0
-S1	Pulsanti per arresto d'emergenza, Sblocco a rotazione Emergency-Stop actuator, non-illuminated, turn to release	M22-PVT	Eaton Moeller	1	0001300005F	/60.3
-S1	Supporto per contatti Fixing adapter	M22-A	Eaton Moeller	1	0001300700A	/60.3
-S1	Elementi di contatto, 1NC, Fissaggio frontale, Cage clamp Contact element, 1N/C, Front fixing, Cage clamp	M22-CK01	Eaton Moeller	2	0001300027C	/60.3
-S3	Pulsante, piatto, bianco, ad impulso Pushbutton actuator, flush, white, spring-return	M22-D-W	Eaton Moeller	1	0001307116L	/60.5
-S3	Elementi di contatto, 1NA, Fissaggio frontale, Cage clamp Contact element, 1N/O, Front fixing, Cage clamp	M22-CK10	Eaton Moeller	1	0001300024F	/60.5
-S3	Supporto per contatti Fixing adapter	M22-A	Eaton Moeller	1	0001300700A	/60.5



Description

Distinta articoli
Parts list

Code

3709303614

Date

11/12/2017

Total

28

Prev

4

Subs

5.1

Page

5

Machine

Masterplat Pgs UL-CSA

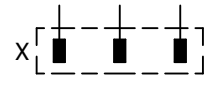

Spina Plug

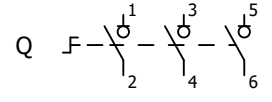

INTERRUTTORE GENERALE
MAIN SWITCH

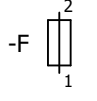

FUSIBILE
FUSIBLE



Connettore
Connector

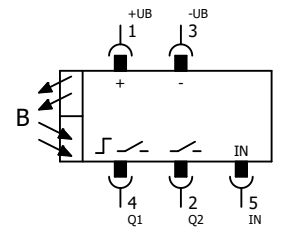

Fotocellula
Photocelle

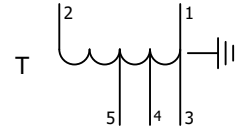

AUTOTRASFORMATORE
AUTOTRANSFORMER

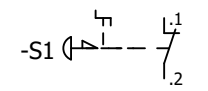

Emergenza
Emergency

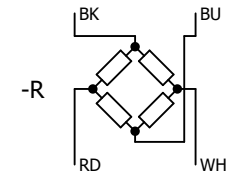

Cella di carico
Loading cell

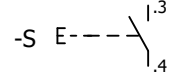

Pulsante
Button

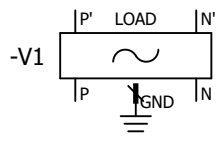

FILTRO
FILTER

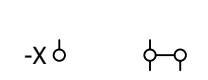

MORSETTO
TERMINALBOARD

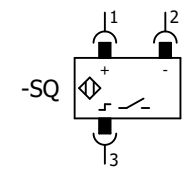

Sensore induttivo
Inductiv sensor

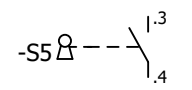

Selettore a chiave
Key selector

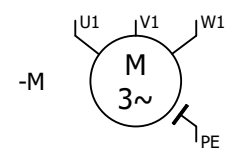

MOTORE
MOTOR

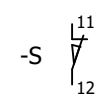

Finecorsa
Limit switch

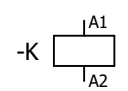

Relè/Contattore
Relais/Contactor

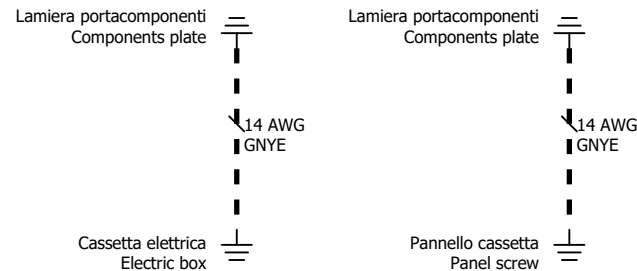
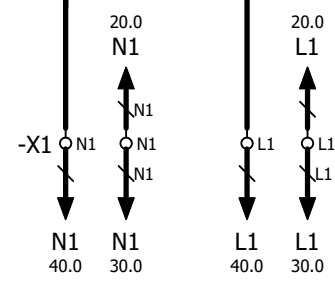
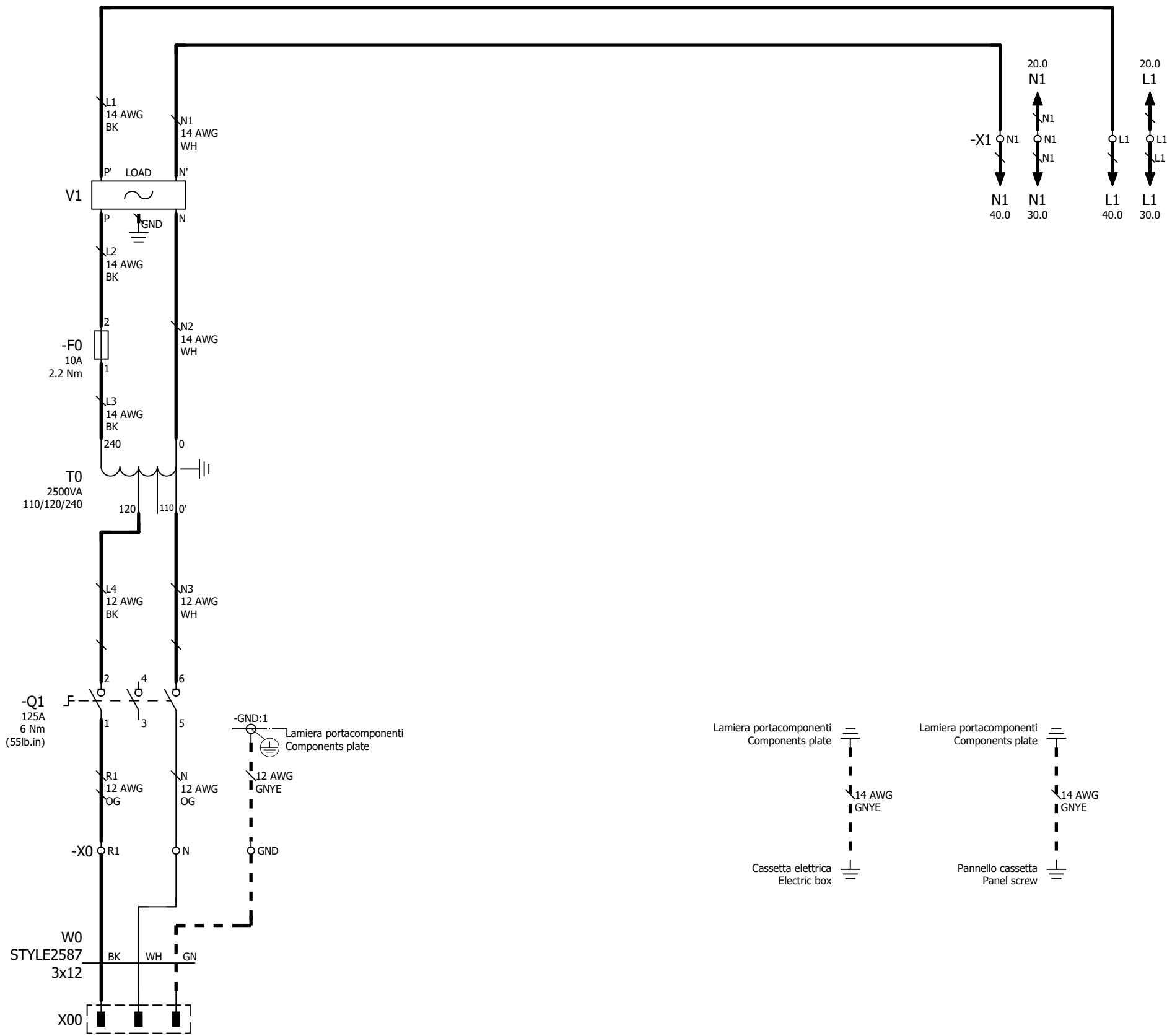

MAIN PROTECTION SHALL BE
INSTALLED IN THE FIELD
FUSE OR CB MAX 20 AMPERE

=+-BOX USE COPPER CONDUCTORS ONLY, MIN. 75°C



Description
**Alimentazione
Power supply**

Code	3709303614	Date	11/12/2017	Total	28	Prev	9	Subs	20	Page	10
Machine	Masterplat Pgs UL-CSA										

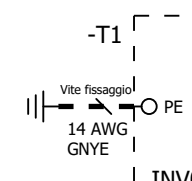
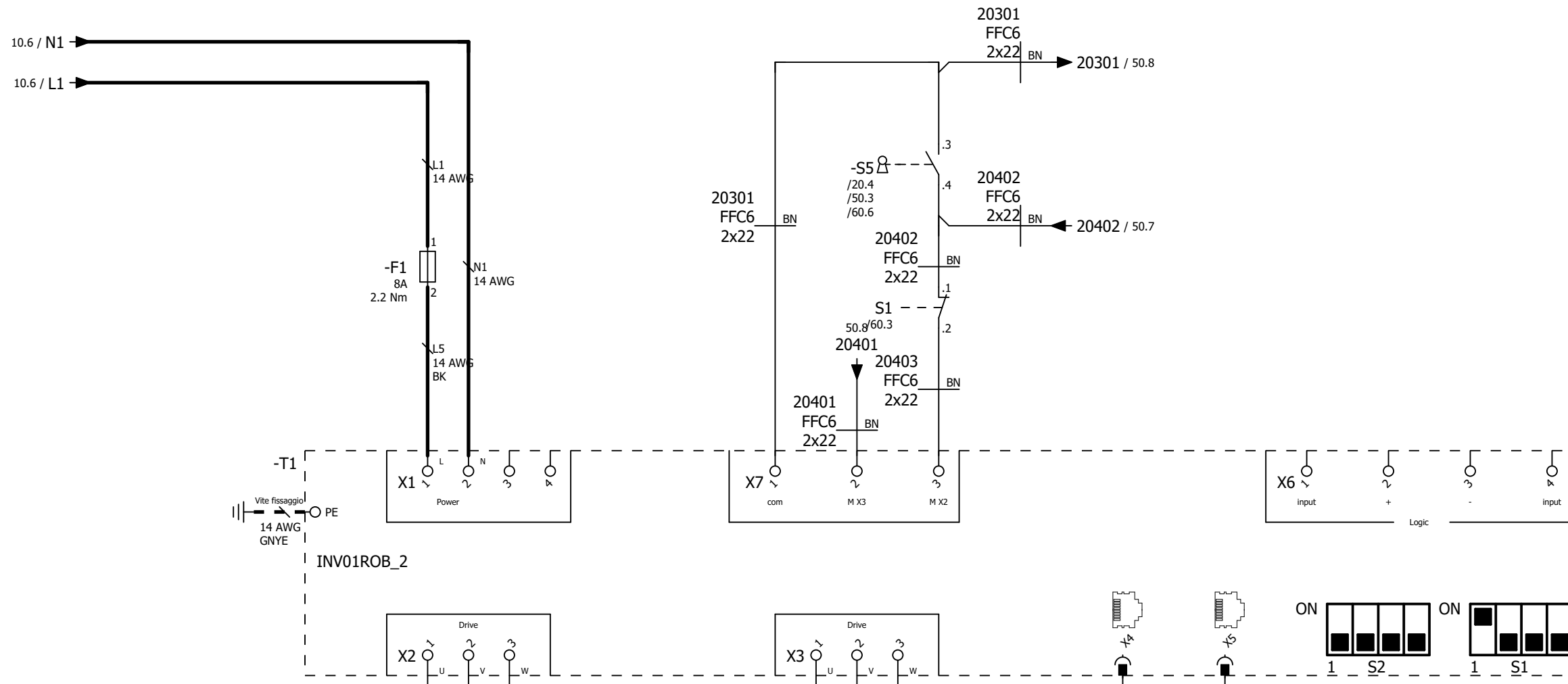

INV01ROB_2

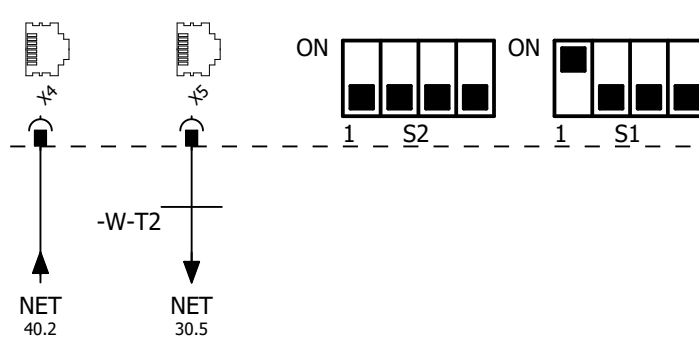
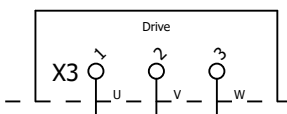
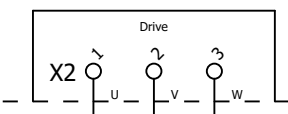

(Only for Robopac)
Per il quadrista:
settare DipSwitch come indicato

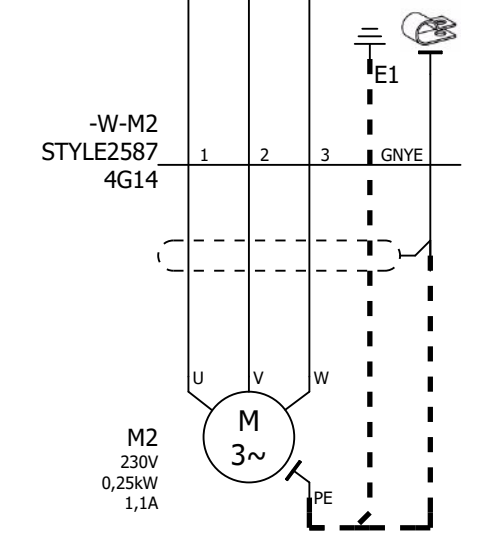

Motore Carrello
Carriage Motor

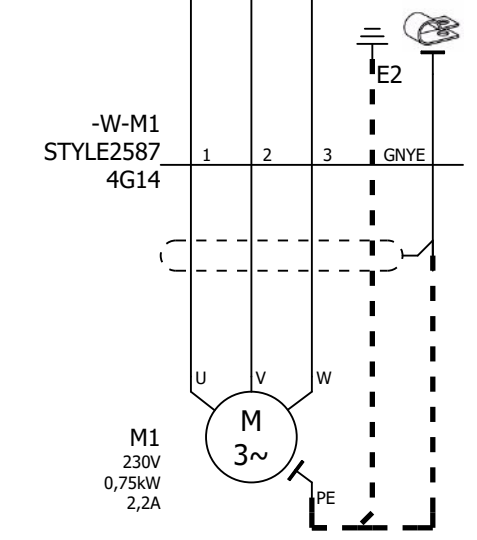

Motore Tavola
Table Motor

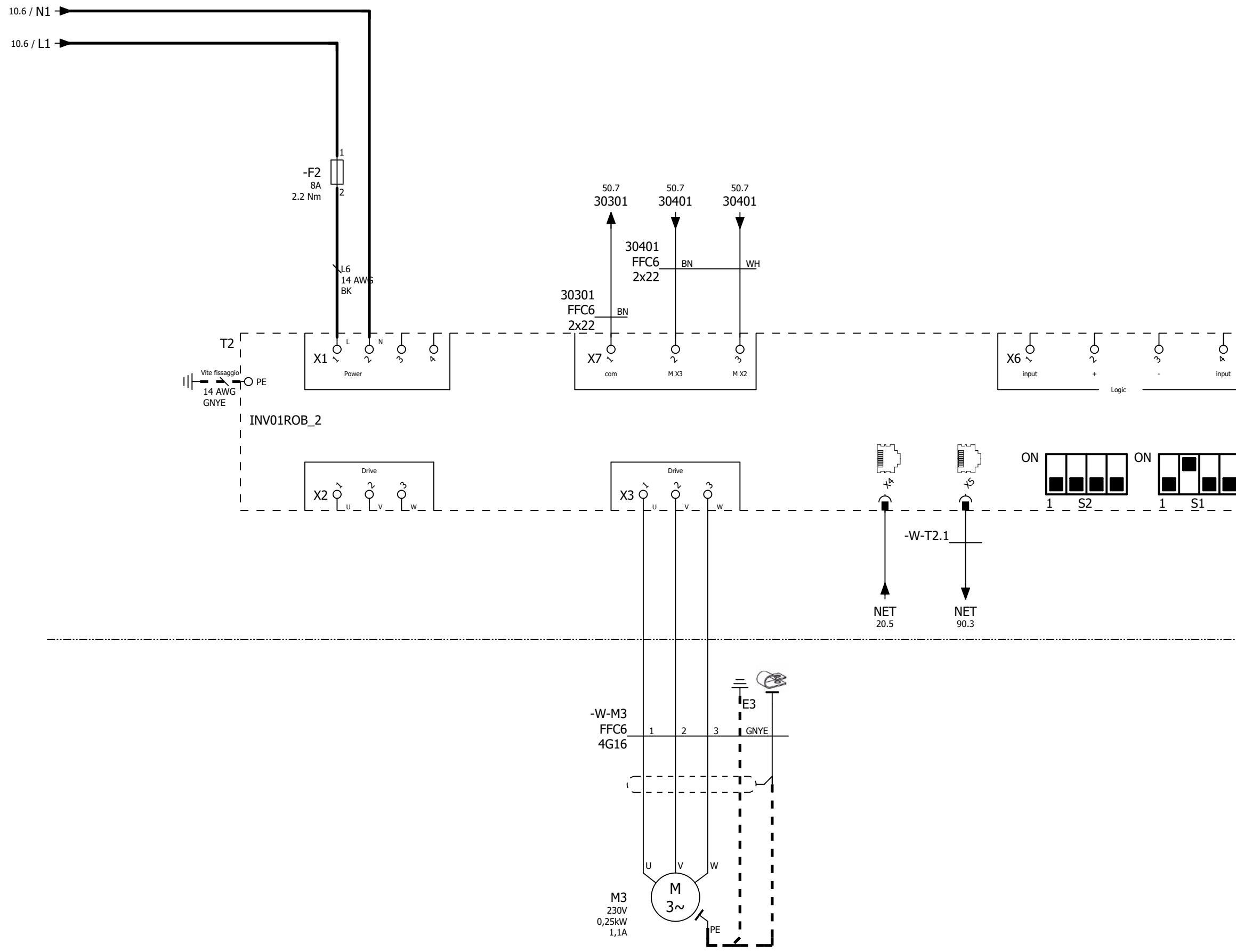

(Only for Robopac)
 Per il quadrista:
 settare DipSwitch come indicato

Motore Svolgimento Film
 Unrolling film Motor

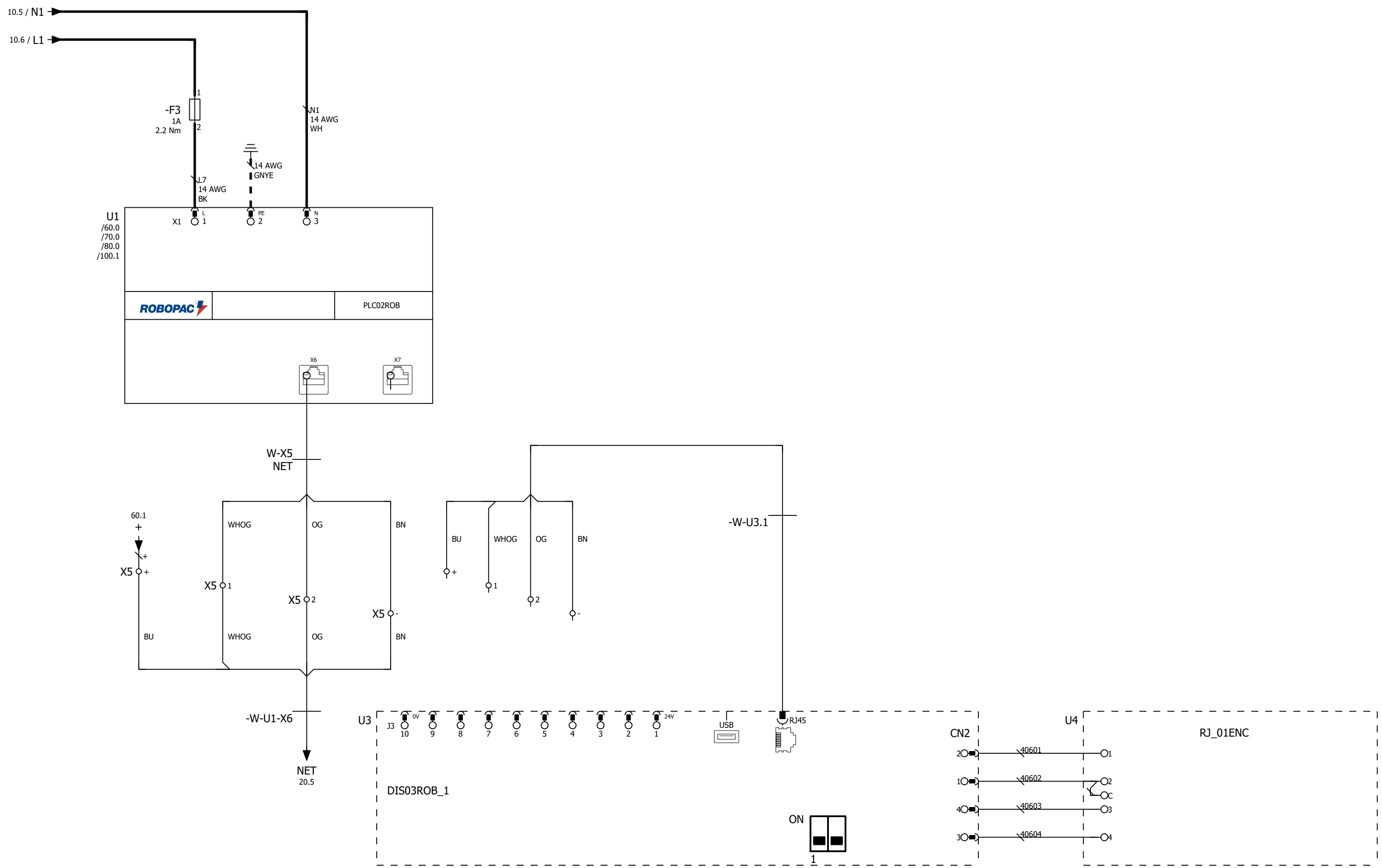

(Only for Robopac)
Per il quadrista:
settare DipSwitch come indicato

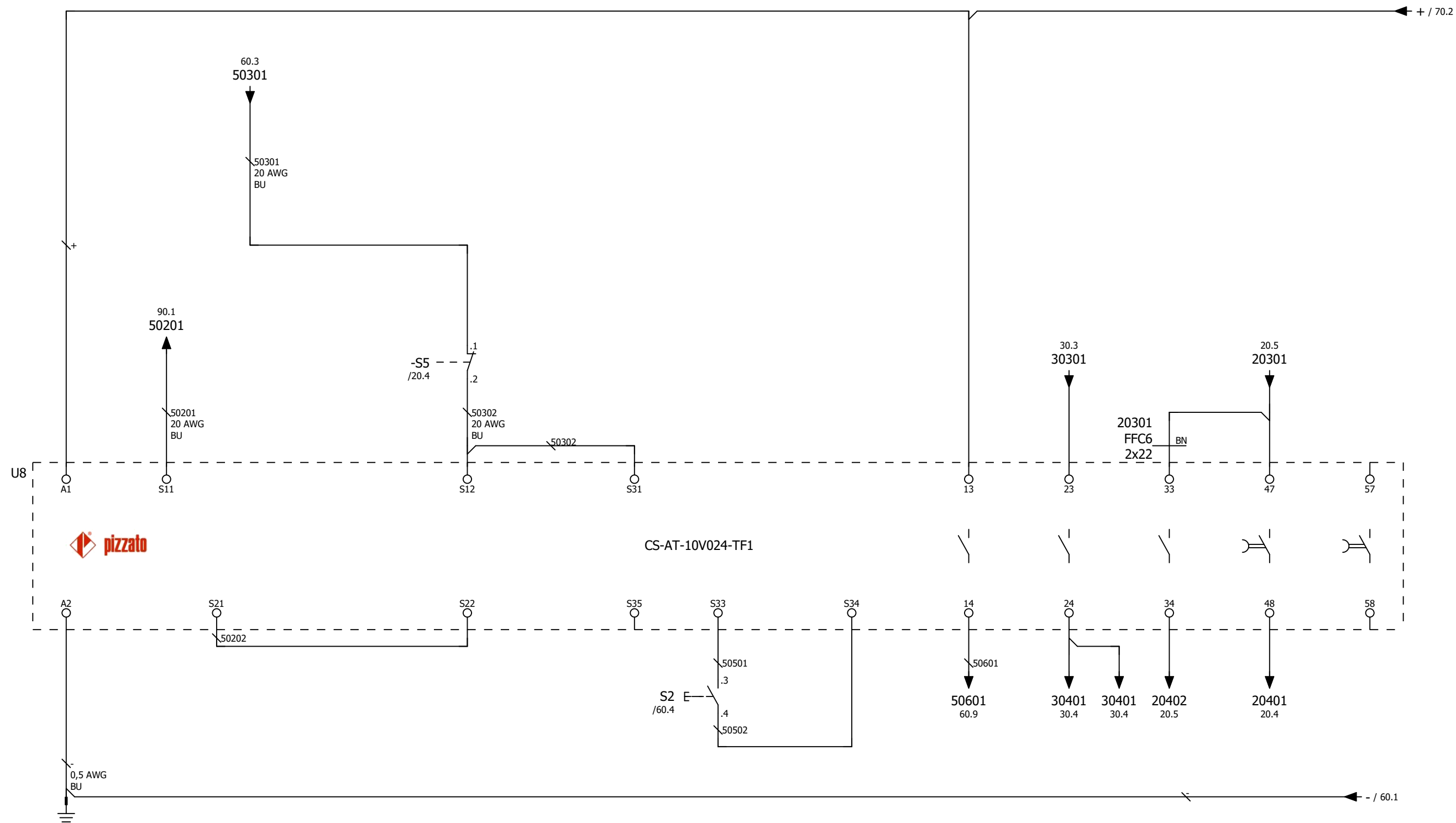

CS-AT-10V024-TF1

Sospensione sicurezza
carrello
Carriage safety
exception

RESET
RESET

Abilitazione Inverters
Inverters enable

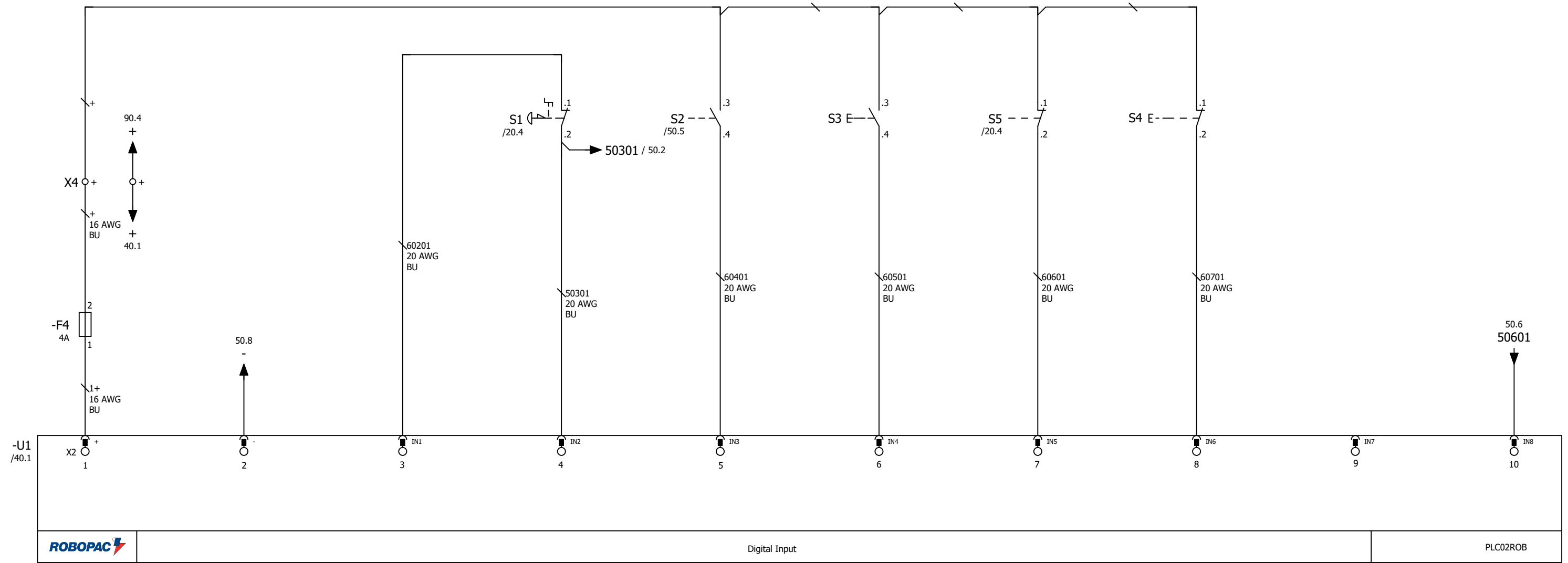

ROBOPAC	Digital Input						PLC02ROB
Alimentazione 24Vdc 24Vdc power supply	Emergenza Emergency stop	RESET RESET	Start	Sospensione sicurezza carrello Carriage safety exception	STOP	Retroazione emergenza Emergency feedback	

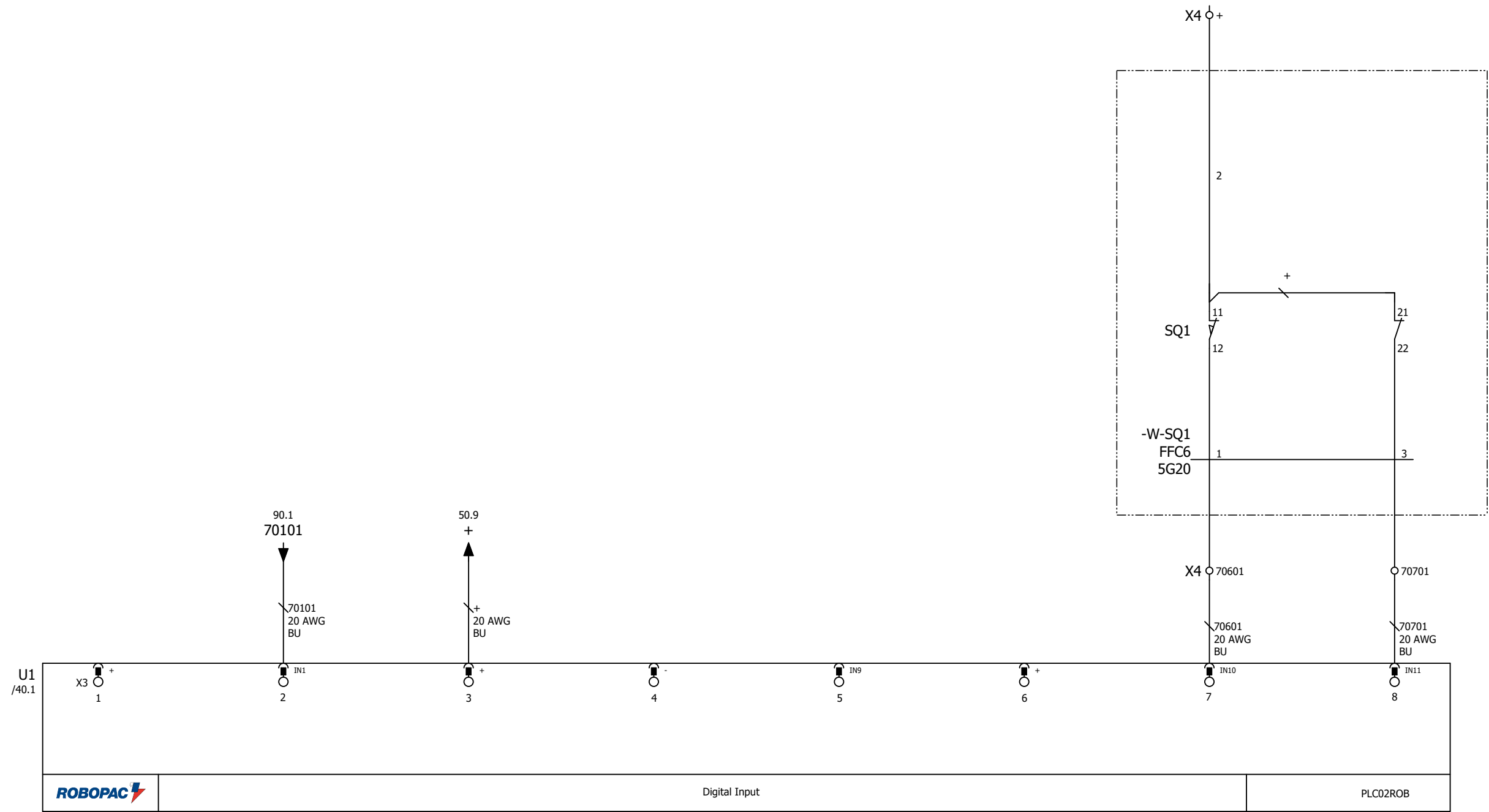

Finecorsa emergenza
carrello
Carriage emergency Endstroke

Finecorsa Alto
High Endstroke

Finecorsa Basso
Low Endstroke



Description
**Circuito Ausiliario
Auxiliary Circuit**

Code 3709303614

Date 11/12/2017

Total 28

Prev 60

Subs 80

Page 70

Machine Masterplat Pgs UL-CSA

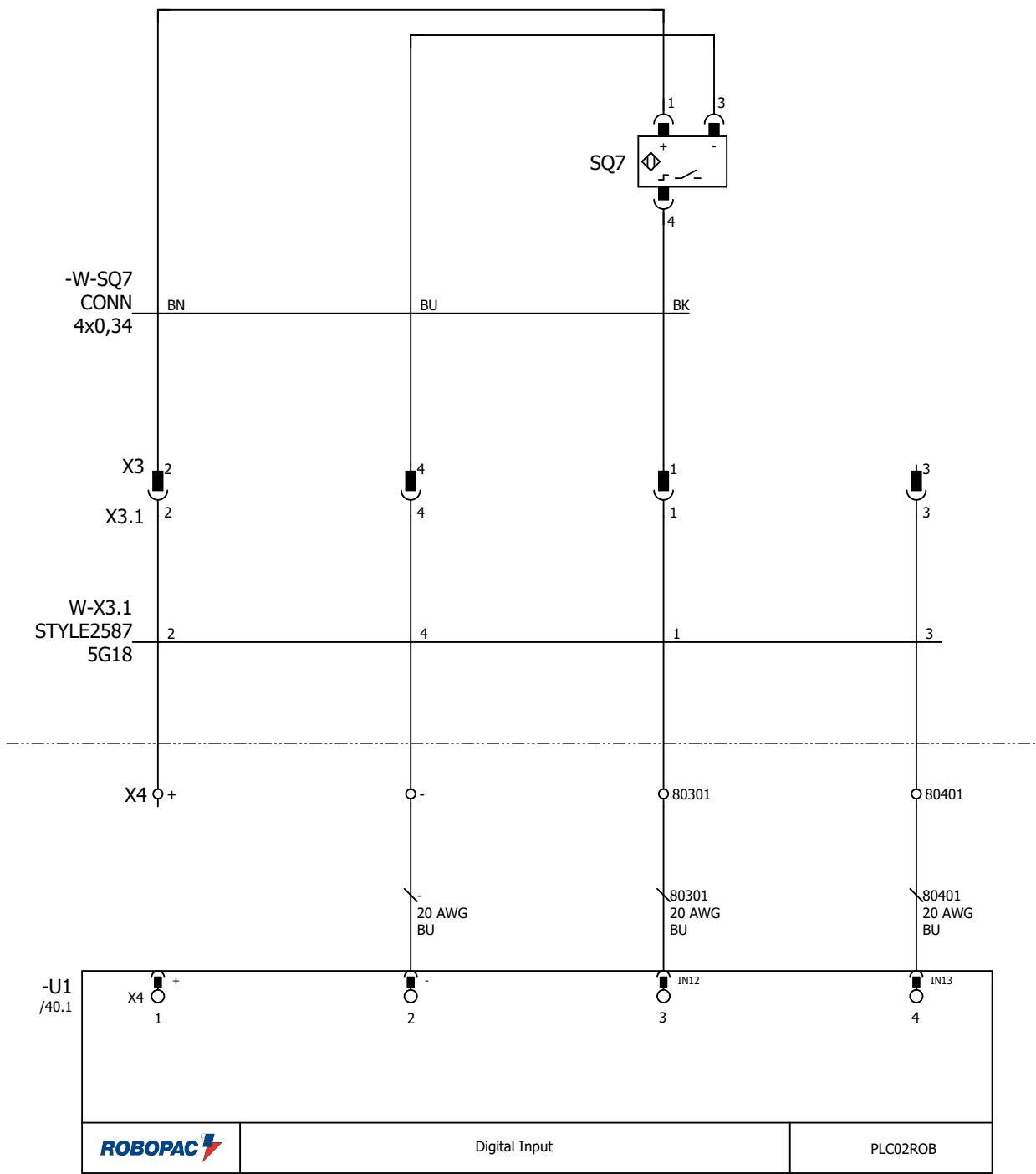

Fase Tavola
Table Phase

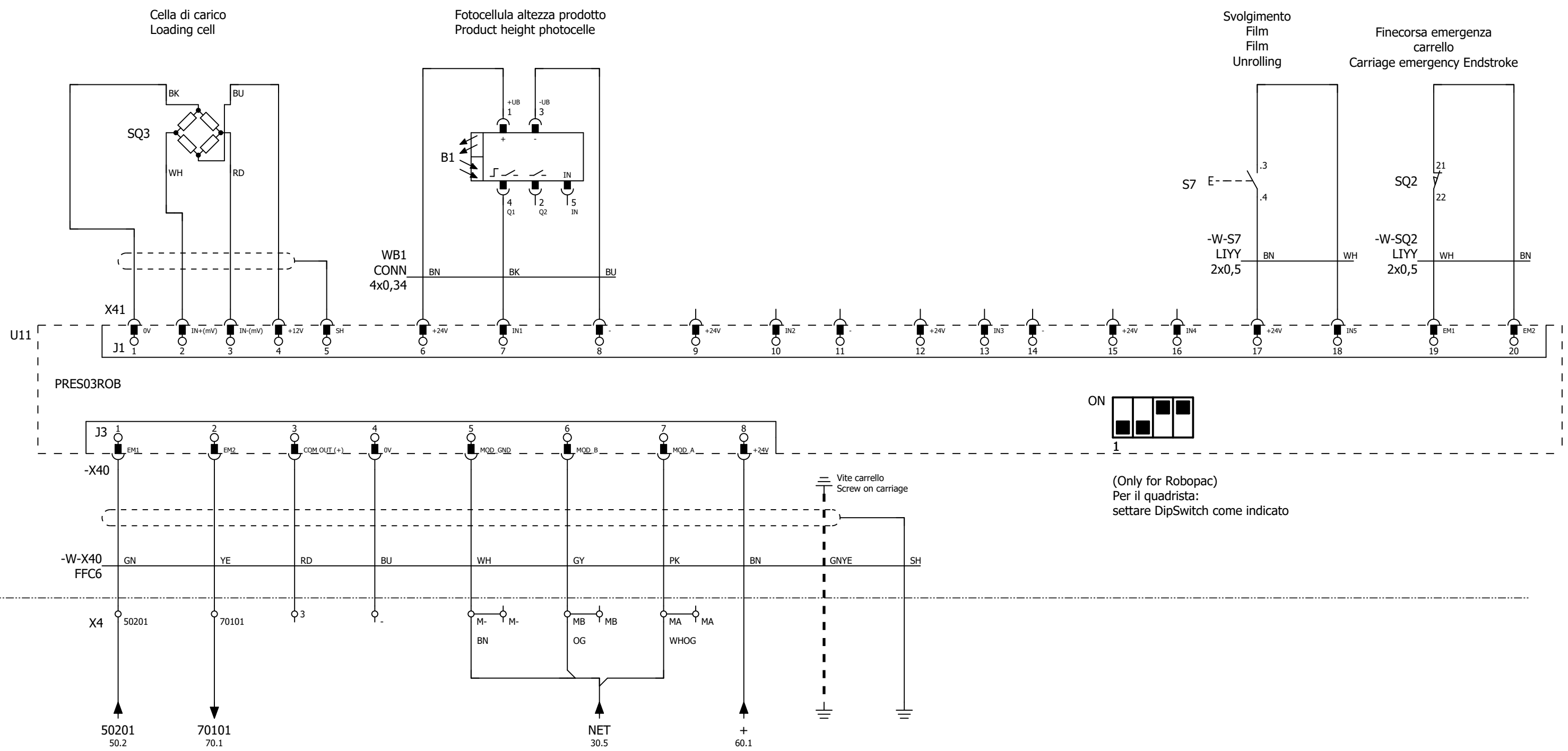

-U1 /40.1 **ROBOPAC** Digital Output PLC02ROB

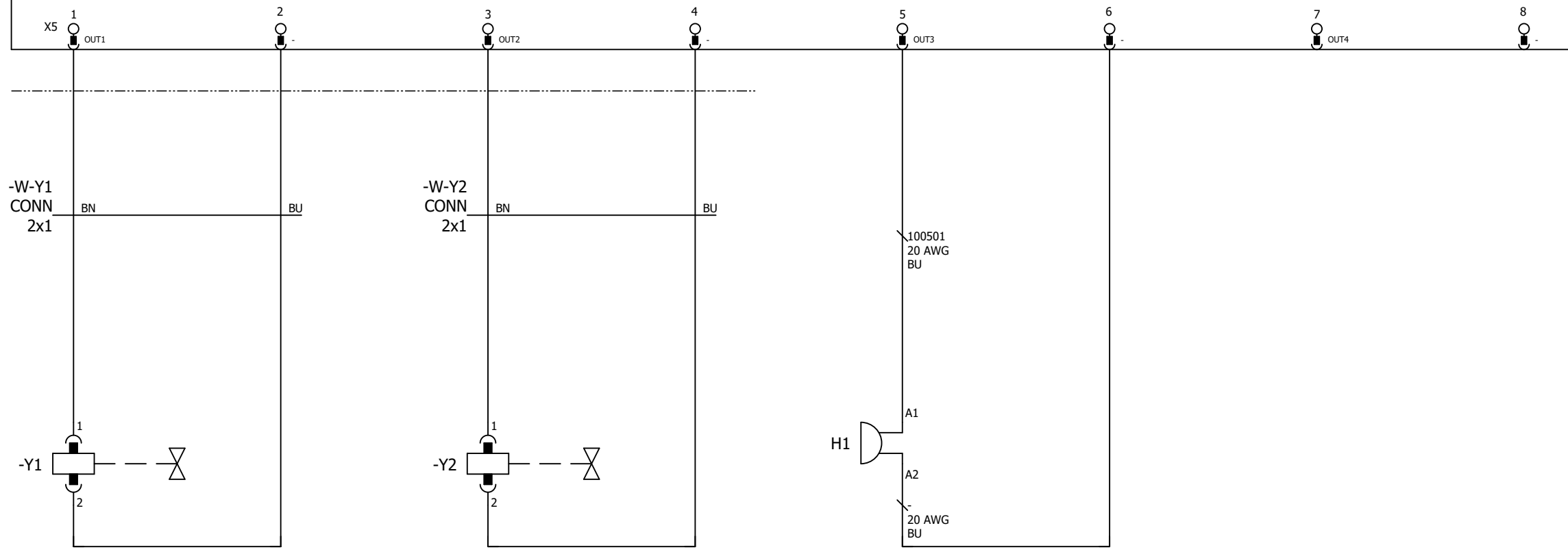

Discesa pressione
Pressure downward

(Optional)

Salita pressione
Pressure upward

(Optional)

Sirena
Siren

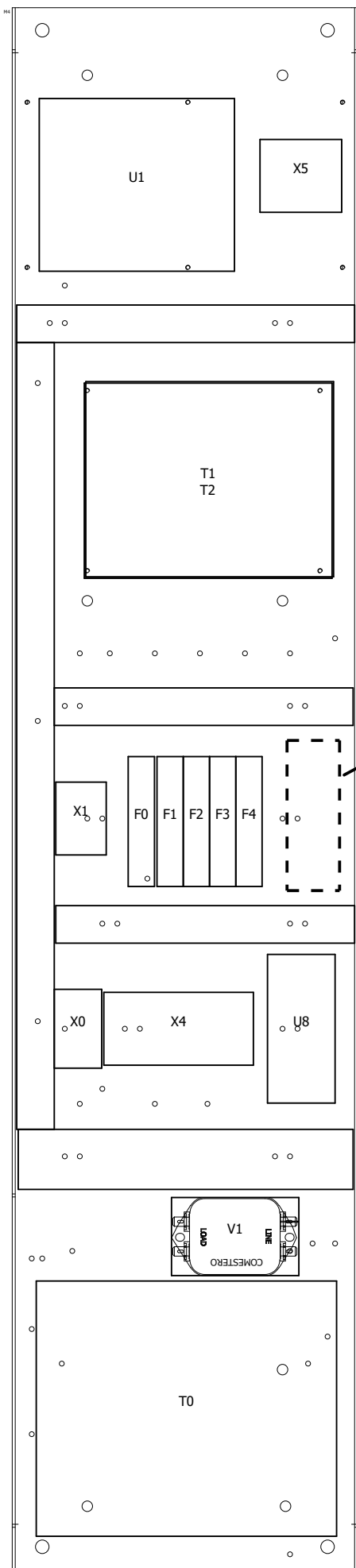

PER IL QUADRISTA: (only for Robopac use):
I cavi di comunicazione (tipo Net) devono essere
posati al di fuori delle canaline.

Lasciare spazio per
modulo 35x100

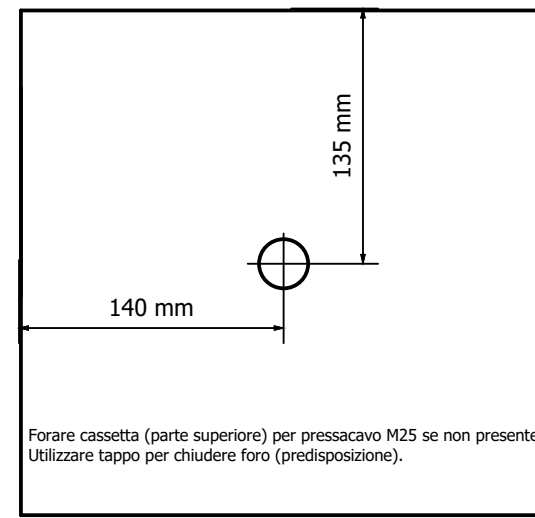

Finecorsa alto/basso



Posizionare la leva 90° a sinistra.

- 11 - Filo 2
- 12 - Filo 1
- 21 - Ponte con contatto 11
- 22 - Filo 3

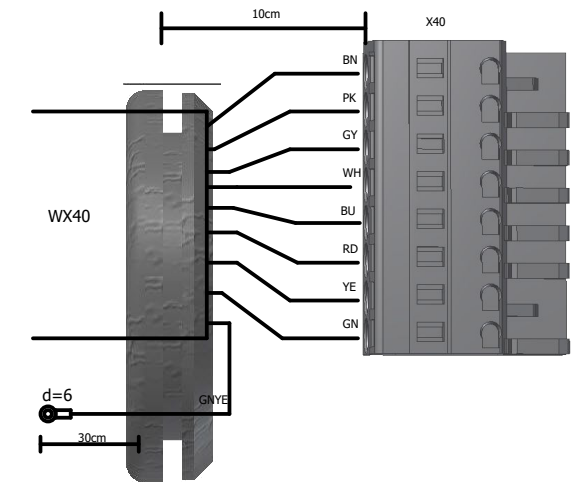

Fissare l'autotrasformatore come in figura,
con i morsetti verso il basso.



Montaggio plexiglass

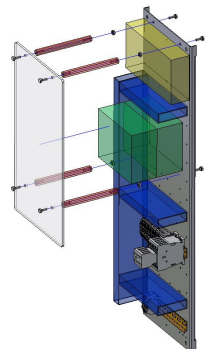

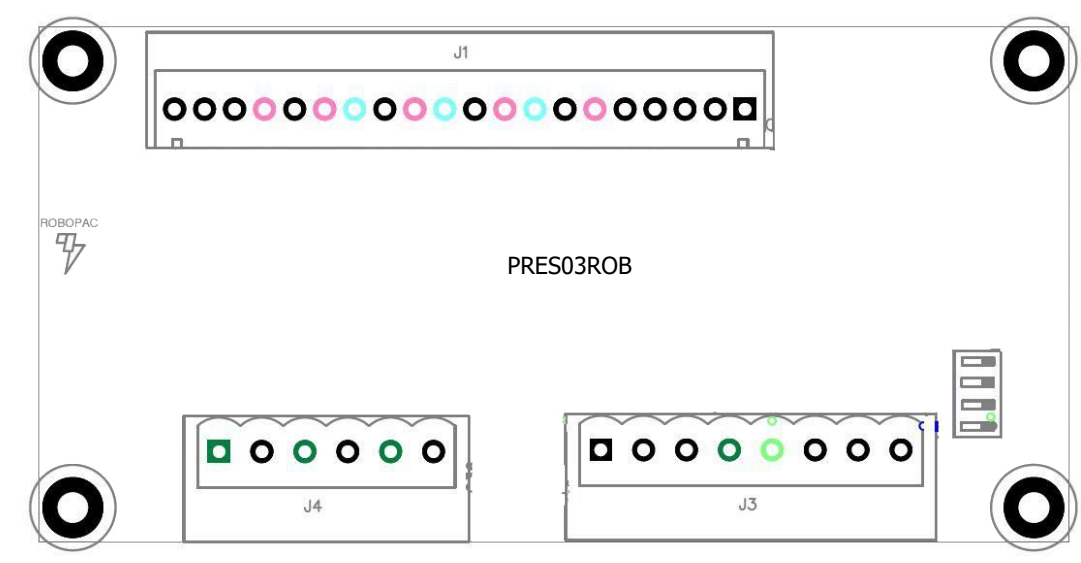
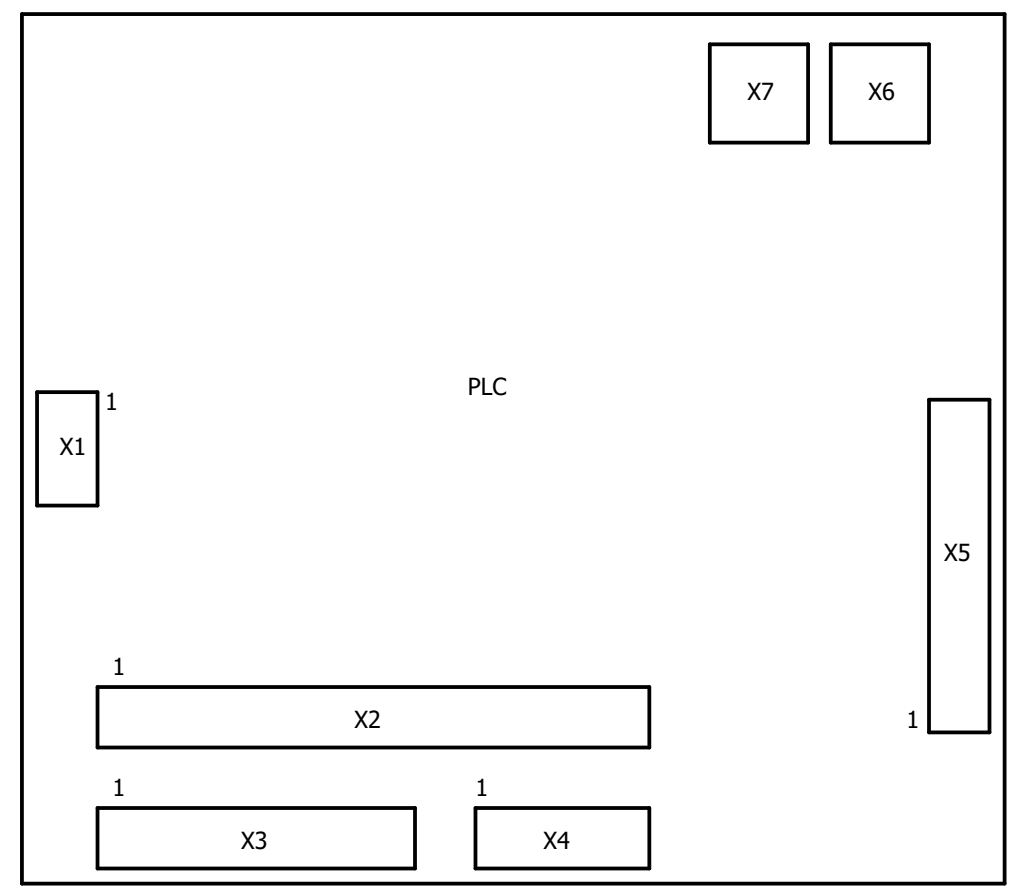
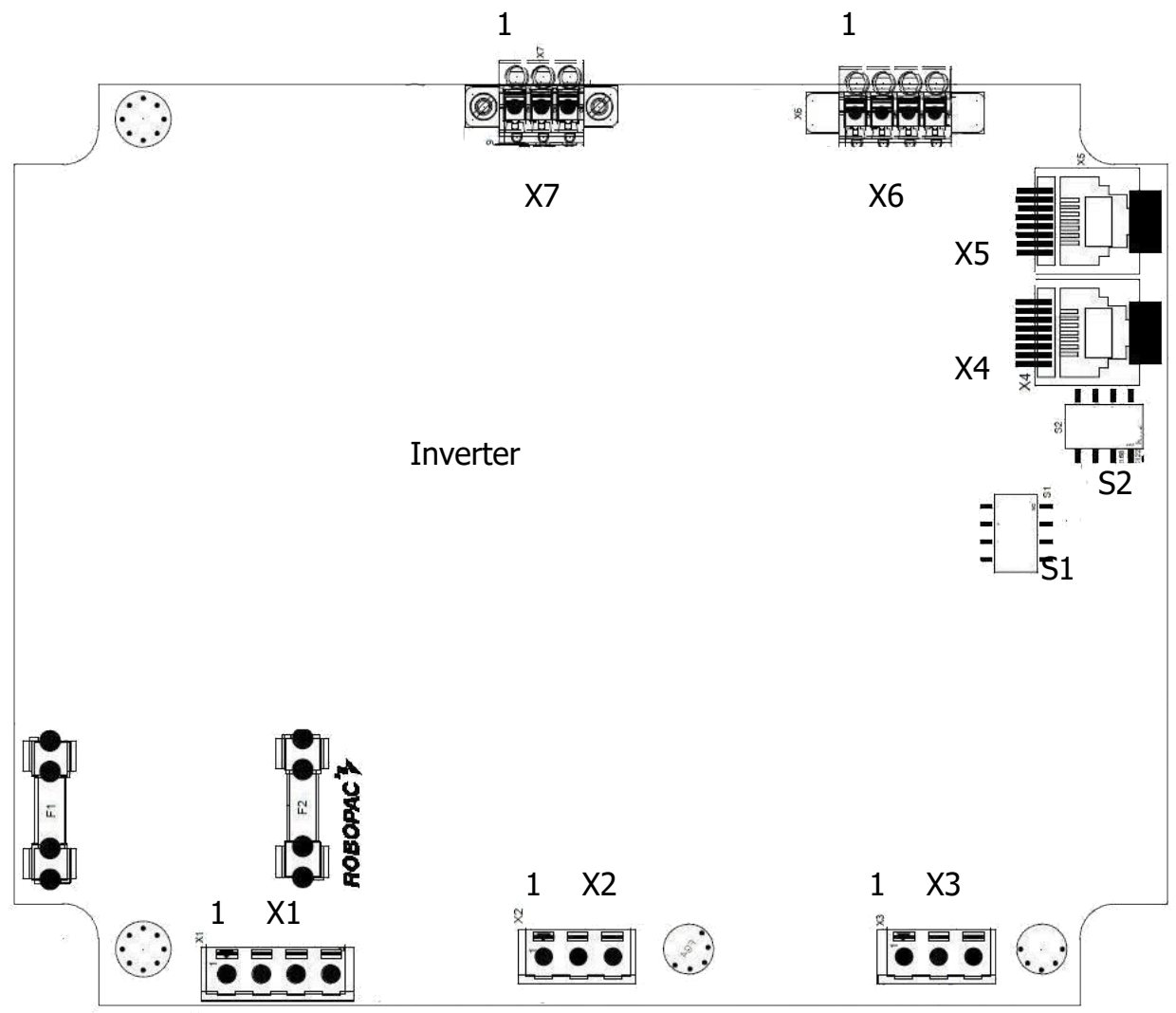

Sommario cavi

Cavo	Origine	N° Conduttori	Sezione	Capicorda origine	Spelatura origine (cm)	Lunghezza fuori cassetta (m)	Spelatura destinazione (cm)	Capicorda destinazione	Destinazione	Note
-W0	-X0	3	12 AWG	--	10	3	5	Puntalino	-X00	
-W-M1	-T1	4G	14 AWG	--	10	2,8	7	Occhiello d=4, Gnd e sch d=5	-M1;-E2	
-W-M2	-T1	4G	14 AWG	--	10	2,6	7	Occhiello d=4, Gnd e sch d=5	-M2;-E1	
-W-M3	-T2	4G	16 AWG	--	10	3,4	7	Occhiello d=4, Gnd e sch d=5	-M3;-E3	In catena portacavo
-W-SQ1	-X4	5G	20 AWG	--	7	2,85	7	Puntalino	-SQ1	In catena portacavo
-W-X3.1	-X4	5G	18 AWG	--	7	2,5	7	Puntalino	-X3.1	
-W-X40	-X4			--	10	3,3	7	--	-X40	In catena portacavo

Schema allacciamento morsetti

Terminal-connection diagram

Destinazioni interne
Internal targets

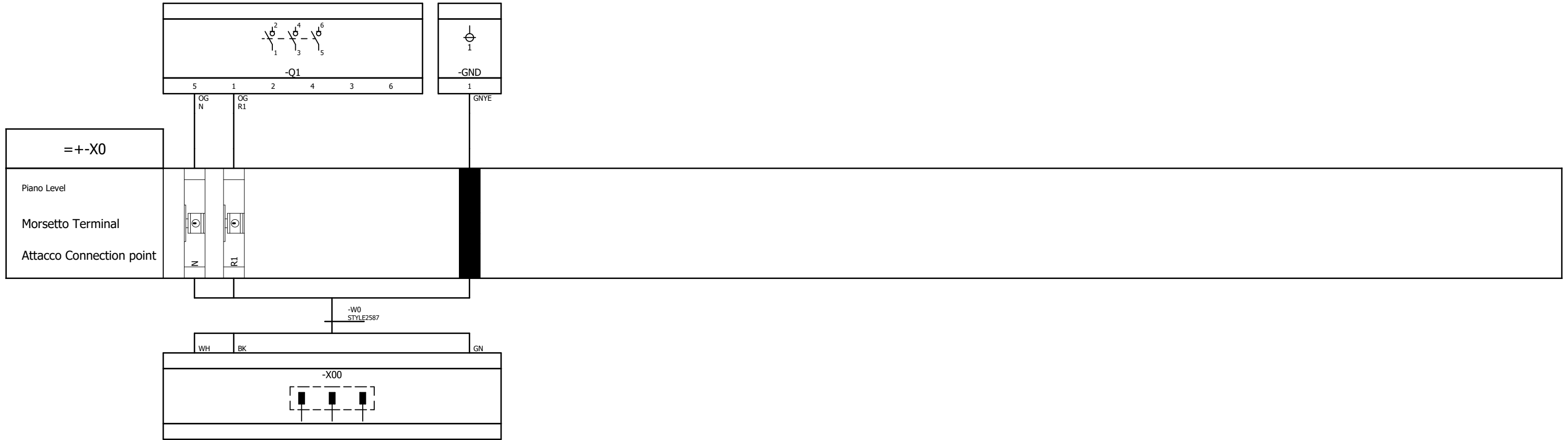

Destinazioni esterne
External targets

Schema allacciamento morsetti

Terminal-connection diagram

Destinazioni interne
Internal targets

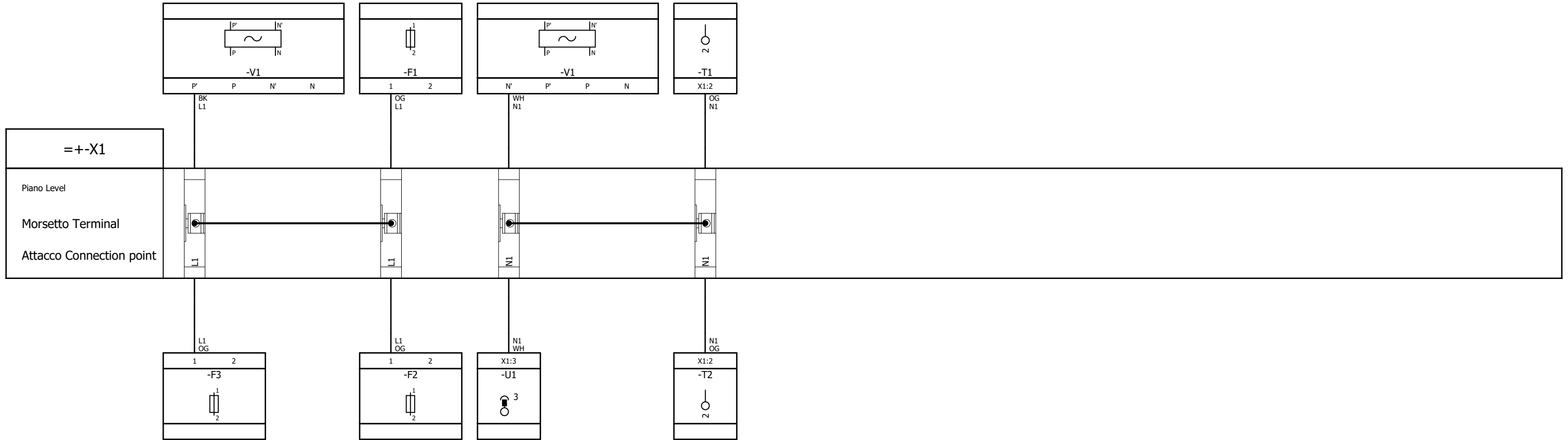

Destinazioni esterne
External targets

Schema allacciamento morsetti

Terminal-connection diagram

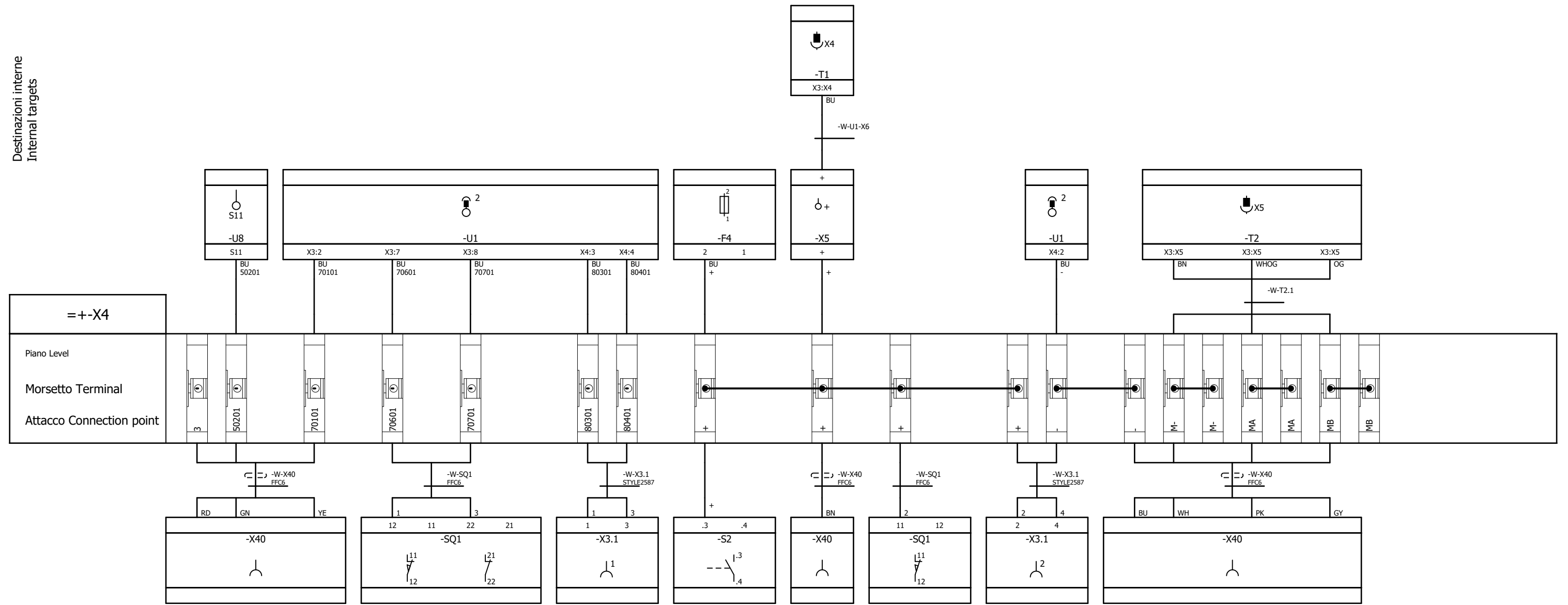

Destinazioni interne
Internal targets

Destinazioni esterne
External targets

Finecorsa Alto
High Endstroke

Finecorsa Basso
Low Endstroke

Fase Tavola
Table Phase

Alimentazione 24Vdc
24Vdc power supply

Alimentazione 24Vdc
24Vdc power supply

Finecorsa Alto
High Endstroke

Description

Morsettiera ausiliari
Aux Terminal strip

Code 3709303614

Date 11/12/2017

Total 28

Prev 118

Subs 120

Page

Machine Masterplat Pgs UL-CSA

Schema allacciamento morsetti

Terminal-connection diagram

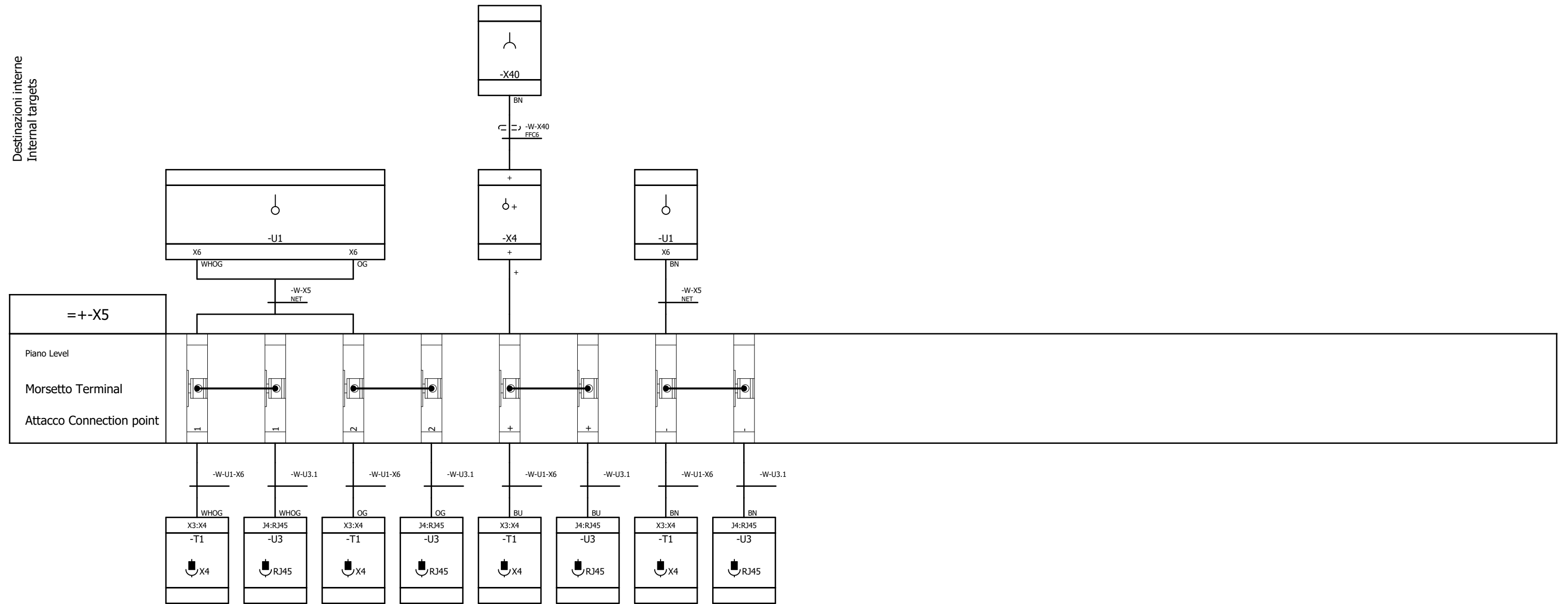

Schema allacciamento connettori

Pin-connection diagram

Destinazioni interne

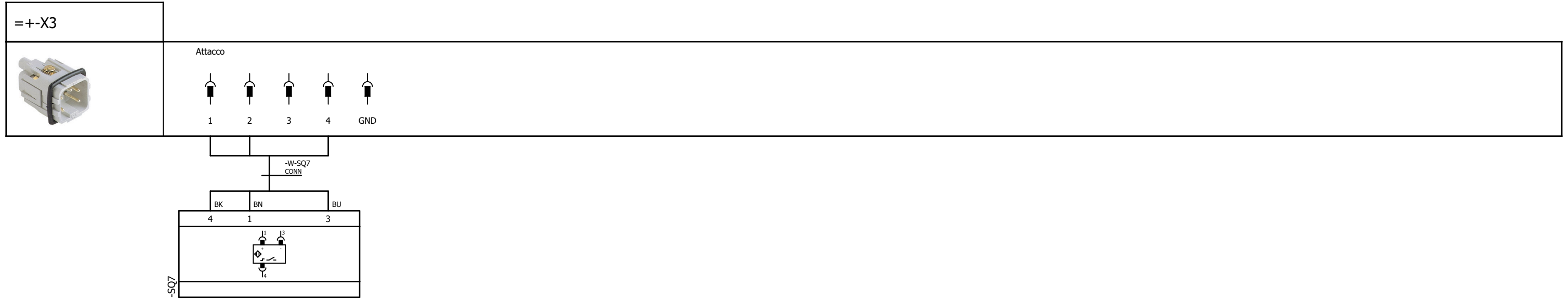

Destinazioni esterne

Fase Tavola
Table Phase

Fase Tavola
Table Phase

Description

Connettore basamento
Base Connector

Code	3709303614	Date	11/12/2017	Total	28	Prev	120	Subs	122	Page	121
Machine	Masterplat Pgs UL-CSA										

Schema allacciamento connettori

Pin-connection diagram

Destinazioni interne

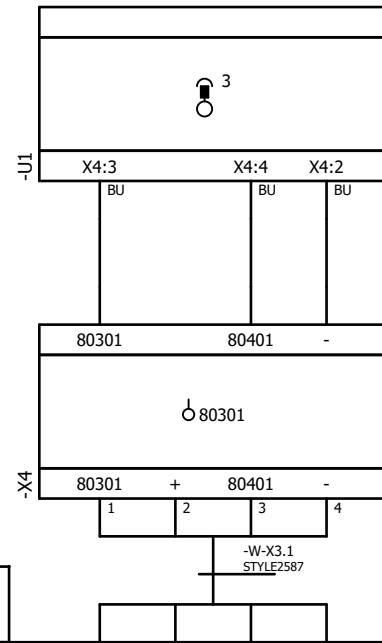

=+-X3.1



Attacco

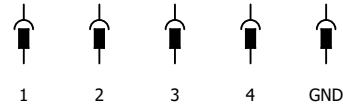

Destinazioni esterne

Fase Tavola
Table Phase

Fase Tavola
Table Phase

Description

Connettore basamento
Base Connector

Code

3709303614

Date

11/12/2017

Total

28

Prev

121

Subs

123

Page

122

Machine

Masterplat Pgs UL-CSA

Schema allacciamento connettori

Pin-connection diagram

Destinazioni interne

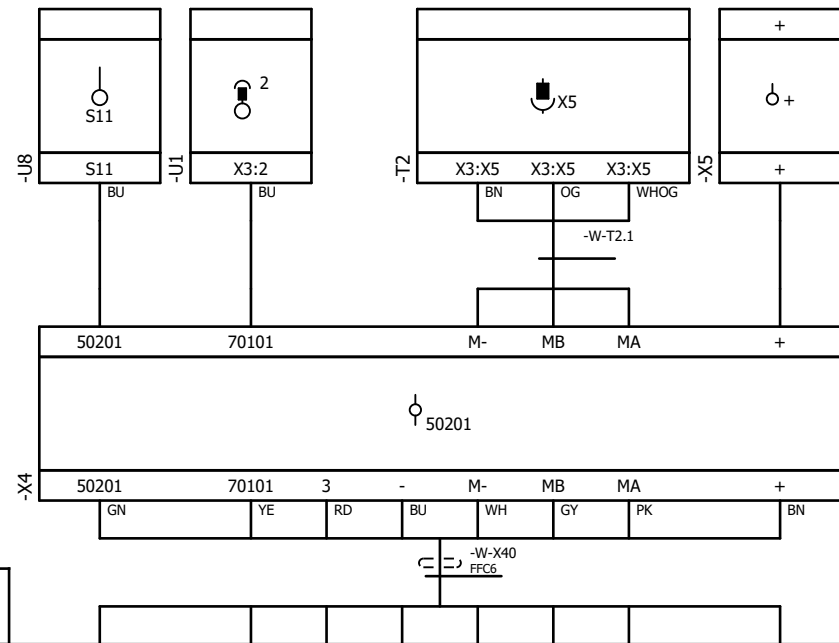

= +-X40



Attacco



Destinazioni esterne

Schema allacciamento connettori

Pin-connection diagram

Destinazioni interne

= +-X41

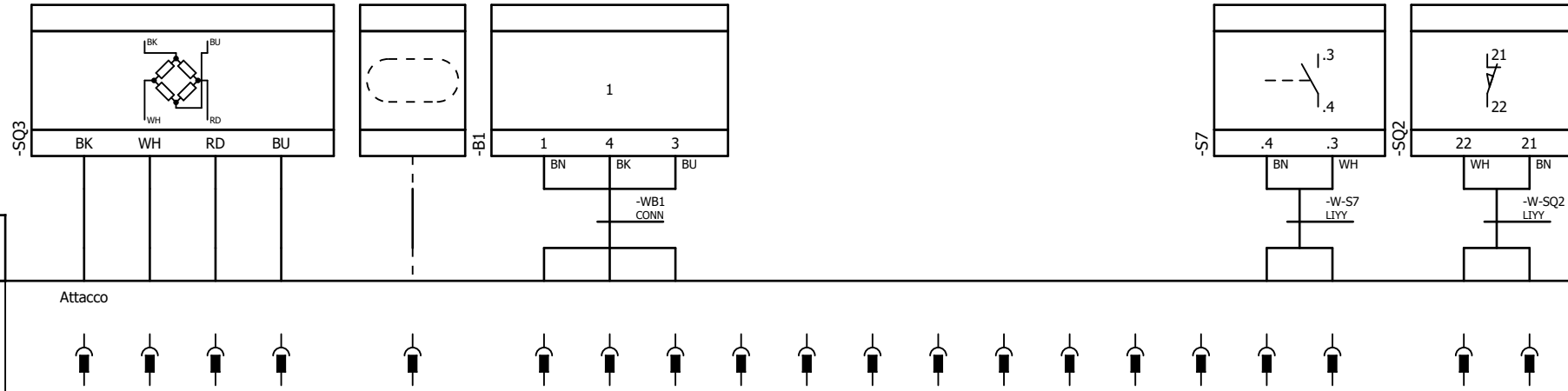

Destinazioni esterne

Svolgimento Film
Film Unrolling

Finecorsa emergenza carrello
Carriage emergency Endstroke



Description

Connettore scheda prestiro
Prestretch card connector

Code 3709303614

Date 11/12/2017

Total 28

Prev 123

Subs

Page

Machine Masterplat Pgs UL-CSA