

# TECHNOPLAT CW CS

Serial n°

 USE AND MAINTENANCE MANUAL

**“TRANSLATION OF THE ORIGINAL  
INSTRUCTIONS”**

**ROTATING PLATFORM MACHINE  
FOR PLASTIC STRETCH FILM WRAPPING**

Instructions manual code 3710309176

English Edition 0/0612





# STAMPARE SU ORIGINALE

## **IT** Dichiarazione "CE" di conformità (Direttiva 2006/42/CE allegato II tipo A)

ROBOPAC S.p.A. dichiara che la macchina per uso artigianale e industriale, identificabile dai riferimenti in calce, è conforme ai requisiti essenziali di sicurezza e di tutela della salute come richiesto dalle Direttive 2006/42/CE, 2004/108 CE e relative modifiche.

## **EN** "CE" declaration of conformity (Directive 2006/42/CE attachment II type A)

ROBOPAC S.p.A. declares that the machine for crafts and industrial use, identifiable by the references at the foot of the page, is in conformity with the essential safety and health requisites required by Directives 2006/42/CE, 2004/108 CE and relevant amendments.

## **FR** Déclaration "CE" de conformité (Directive 2006/42/CE annexe II type A)

ROBOPAC S.p.A. déclare que la machine est conforme aux conditions essentielles requises concernant la sécurité et la préservation de la santé conformément aux Directives 2006/42/CE, 2004/108 CE et modifications correspondantes pour une utilisation artisanale et industrielle et pouvant être identifiée par les références citées au bas de la page.

## **DE** "CE"-Konformitätserklärung (Richtlinie 2006/42/EG, Anlage II Typ A)

ROBOPAC S.p.A. erklärt hiermit, dass die durch die Angaben im Fuß dieses Dokuments identifizierbare Maschine für den handwerklichen und industriellen Einsatz in Übereinstimmung steht mit den grundlegenden Sicherheits- und Gesundheitsschutzvorgaben gemäß den Richtlinien 2006/42/EG, 2004/108 EG und zugehörigen Änderungen.

## **ES** Declaración de conformidad "CE" (Directiva 2006/42/CE anexo II tipo A)

ROBOPAC S.p.A. declara que la máquina para uso artesanal e industrial, que se identifica en base a las referencias al pie de página, es conforme a los requisitos esenciales de seguridad y de tutela de la salud según lo exigen las Directivas 2006/42/CE, 2004/108 CE y sus relativas modificaciones.

## **PT** Declaração "CE" de conformidade (Directiva 2006/42/CE anexo II tipo A)

ROBOPAC S.p.A. declara que a máquina para uso artesanal e industrial, identificável mediante as referências abaixo indicadas, está conforme aos requisitos essenciais de segurança e salvaguarda da saúde, previstos pelas Directivas 2006/42/CE, 2004/108 CE e relativas modificações

## **EL** Δήλωση συμμόρφωσης "CE" (EK) (Οδηγία 2006/42/EK - συννημένο II - τύπος A)

Η ROBOPAC S.p.A. δηλώνει ότι η μηχανή βιομηχανικής και βιοτεχνικής χρήσης, που φέρει τα παρακάτω αναγνωριστικά στοιχεία, είναι κατασκευασμένη σε συμμόρφωση με τις βασικές απαιτήσεις ασφαλείας και προστασίας της υγείας, όπως επιβάλλεται από τις Οδηγίες 2006/42/ΕΚ, 2004/108 ΕΚ και περαιτέρω τροποποιήσεις.

## **NL** EG-Verklaring van overeenstemming (Richtlijn 2006/42/EG bijlage II type A)

ROBOPAC S.p.A. verklaart dat de machine die bedoeld is voor ambachtelijke en industriële omgevingen met de hierbij vermelde identificatiegegevens voldoet aan de essentiële veiligheids- en gezondheidsvereisten zoals deze zijn voorgeschreven door de Richtlijnen 2006/42/EG, 2004/108 EG en daarop volgende wijzigingen.

## **DA** "EF" OVERENSSTEMMELSESERKLÆRING (Direktiv 2006/42/CE bilag II type A)

ROBOPAC S.p.A. erklærer at maskinen til håndværksmæssig og industrielt brug, som kan identificeres ved referencerne ved siden af, er i overensstemmelse med de væsentlige krav om sikkerhed og helbredsbeskyttelse som krævet af Direktiverne EF 2006/42, EF 2004/108 og deres følgende ændringer.

## **SV** "CE"-konformitetsförklaring (Direktiv 2006/42/CE bilaga II typ A)

ROBOPAC S.p.A. förklarar att denna maskin som är avsedd för hantverk och industriellt bruk, samt kan identifieras av referensinformationen nedan, motsvarar de grundläggande säkerhets- och hälsokrav som uppställts i Direktiv 2006/42/CE, 2004/108 CE och senare ändringar.

## **FI** "CE" Vaatimustenmukaisuusvakuutus (Direktiivi 2006/42/CE liite II tyyppi A)

ROBOPAC S.p.A. vakuuttaa, että teollisuus- ja pienteollisuuskäyttöön tarkoitettu laite, joka on tunnistettavissa alla olevista viitteistä, vastaa turvallisuudesta ja työterveysuojelusta säädettyjä vaatimuksia annettujen Direktiivien 2006/42/CE, 2004/108 CE sekä niiden myöhempien muutosten mukaisesti.

## **NO** "CE" samsvareklæring (Direktiv 2006/42/CE vedlegg II type A)

ROBOPAC S.p.A. erklærer at maskinen for håndverks- og industriell bruk, kjennetegnet av referansene nedenfor, samsvarer grunnleggende sikkerhetskrav og sikring av helse som påkrevd i direktivene 2006/42/CE, 2004/108 CE og gjeldende endringer.

## **CS** PROHLÁŠENÍ O SHODNOSTI CE (Směrnice 2006/42/CE příloha Typ A)

ROBOPAC S.p.A. prohlašuje, že stroj pro řemeslnické a průmyslové využití, identifikovatelný podle údajů uvedených v záhlaví, se shoduje se základními požadavky na bezpečnost a ochranu zdraví tak, jak je to požadováno ve směrnicih 2006/42/CE, 89/339 CEE a v jejich úpravách.

## **ET** "EÜ" vastavustunnistus (Direktiiv 2006/42/EÜ lisa A tüüp)

ROBOPAC S.p.A. deklareerib, et seade on tööstuslikuks ja käsitööstuslikuks kasutamiseks, identifitseerimiseks vaata allpool ära toodude viiteid, ning vastab peamistele ohtuse ja tervisekaitse nõuetele nagu seda nõutud Direktiivis 2006/42/EÜ, 2004/108 EÜ ja järgnevates parandustes.

# STAMPARE SU ORIGINALE

**LV "CE" atbilstības apliecinājums**  
(Eiropas Savienības direktīvas 2006/42/CE pielikums II tips A)  
Uzņēmums ROBOPAC S.p.A. apliecina, ka amatnieciskai un rūpnieciskai izmantošanai paredzēta mašīna, kuras identifikācijas dati atrodas apakšējā daļā, atbilst vispārējām drošības un veselības aizsardzības prasībām, kuras ir aprakstītas ES direktīvās 2006/42/CE, 2004/108 CE un atbilstošajos grozījumos.

**LT "ES" atitikimo deklaracija**  
(ES Direktyva 2006/42 pridėtas II tipas A)  
ROBOPAC S.p.A. pareiškia, kad meistriniam ir industriniam naudojimui irengimas pripažintas atitinkantis būtinus saugumo ir sveikatos apsaugos reikalavimus kaip nurodyta direktyvose 2006/42/CE, 2004/108 CE su atitinkamais pasikeitimais.

**HU CE megfelelısségi nyilatkozat**  
(2006/42 számú CE utasítás, II melléklet, A típus)  
A ROBOPAC S.p.A. kijelenti, hogy a kisipari és ipari használatra szolgáló, a lap alján lévő hivatkozások alapján azonosítható gép, megfelel az alapvető biztonsági és egészségvédelmi követelményeknek, amint azt a 2006/42 számú CE, a 2004/108 számú CE utasítások és vonatkozó módosításai elıírják.

**PL Deklaracja "CE" zgodności**  
(Dyrektywa 2006/42/WE załącznik II typ A)  
Robopac S.p.A. oświadcza, że urządzenie przeznaczone do użytku drobnej wytwórczości oraz na skalę przemysłową rozpoznawalne poprzez podane poniżej oznaczenia, jest zgodne z podstawowymi wymogami w zakresie zdrowia i ochrony bezpieczeństwa zgodnie z zaleceniami Dyrektyw 2006/42/WE, 2004/108 WE wraz z późniejszymi zmianami.

Persona autorizzata a costituire il fascicolo tecnico - Person authorised to write the technical sheet - Personne autorisée à rédiger le document technique - Zur Verfassung des technischen Heftes befugte Person - Persona autorizada para realizar el folleto de datos técnicos - Pessoa autorizada à composição do manual técnico - Άτομο που είναι εξουσιοδοτημένο να δημιουργήσει το τεχνικό φυλλάδιο - Persoon bevoegd om het technische dossier samen te stellen - Person der er autoriseret til at danne den endelige tekniske data - Person som är auktoriserad att framställa den tekniska dokumentationen - Henkilö, joka on valtuutettu laatimaan tekniset tiedot sisäلتävän kirjaseen - Person som har autorisasjon til å lage det tekniske heftet - Osoba pověřená zpracováním technické dokumentace - Tehnilise toimiku koostamiseks volitatud isik - Asmuo, įgaliojotas sudaryti techninę knygėlę - Persona ir autorizėta izveidot tehnisko mapi - Műszaki anyag elkészítésére feljogosult személy - Osoba upoważniona do przygotowania dokumentacji technicznej - Osoba oprávněná vypracováním technické dokumentácie - Oseba, pooblašćena za sestavo tehničnega zvezka - Personaă autorizată să constituie fascicolul tehnic - Човек оторизиран за изготвяне на техническата книжка

Modello - Model - Modèle - Modell - Modelo  
Modelo - αριθμόςσειράς - Model - Model - Modell  
Modell - Malli - Model - Mudel - Modelis  
Modelis - Modell - Model - Model - Model - Model - Модел

Matricola - Serial number - Matricule - Seriennummer - Matricula  
Número de série - Μοτρίλο - Seriennummer - Seriennummer - Serien  
Seriennummer - Sarjanumero - Výrobní číslo - Registrėerimistunnistus  
Nomenklatūras numurs - Registracijos numeris - Gépszám  
Numer fabryczny - Výrobné číslo - Matična številka  
Număr serie - Сериен номер

**SK ES vyhlásenie o zhode**  
(Smernica 2006/42/ES príloha II. typ A)  
Akciová spoločnosť ROBOPAC S.p.A., identifikovateľná podľa vyššie uvedených údajov v záhlaví, prehlasuje, že strojné zariadenie určené pre remeselné a priemyselné použitie je v súlade so základnými bezpečnostnými predpismi a s požiadavkami na ochranu zdravia v zmysle ustanovení smerníc 2006/42/ES, 2004/108 ES.

**SL Izjava "CE" o ustrezanju**  
(Smernica 2006/42/CE, priloga II, tip A)  
ROBOPAC S.p.A. izjavlja, da naprava, izdelana za uporabo v industrijskih postopkih, razpoznavna po navedenih oznakah, ustreza osnovnim pogojem za varnost pri delu in za varovanje zdravlja, določenim v Smernicah 2006/42/CE, 2004/108 CE ter v dodatnih predpisih.

**RO Declarație "CE" de conformitate**  
(Directiva 2006/42/CE anexa tip A)  
ROBOPAC S.p.A. declară că mașina pentru uz artizanal și industrial, identificabilă de referințele din josul paginii, este în conformitate cu cerințele esențiale de siguranță și de protecție a sănătății conform cerințelor din directivele 2006/42/CE, 2004/108 CE și modificările lor aferente

**BG Декларация "EO" за съответствие**  
(Директива 2006/42/EO, приложение II, вид A)  
ROBOPAC S.p.A. декларира, че машината за занаятчийска и индустриална употреба, подлежаща на идентификация чрез данните в долната част, съответства на основните условия за безопасност и здравеопазване, както се изисква от Директиви 2006/42/EO, 2004/108 EO и съответните промени.

Aetna Group S.p.A.  
Robopac Sistemi Division  
S.S. Marecchia, 59  
47827 Villa Verucchio, Rimini, Italy

# TABLE OF CONTENTS

<b>1</b>	<b>GENERAL INFORMATION</b>	
1.1.	PURPOSE OF THE MANUAL.....	3
1.2.	MANUFACTURER AND MACHINE IDENTIFICATION .....	4
1.3.	TERMS AND DEFINITIONS.....	5
1.4.	MODES OF REQUESTING FOR ASSISTANCE.....	5
1.5.	ATTACHED DOCUMENTATION .....	6
<b>2</b>	<b>SAFETY INFORMATION</b>	
2.1.	GENERAL SAFETY PRECAUTIONS .....	7
2.2.	SAFETY WARNINGS FOR HANDLING AND INSTALLATION .....	8
2.3.	SAFETY WARNINGS FOR USE AND OPERATION .....	9
2.4.	SAFETY WARNINGS RELATED TO INCORRECT USE.....	10
2.5.	SAFETY WARNINGS ON RESIDUAL RISKS.....	12
2.6.	SAFETY WARNINGS FOR REGULATIONS AND MAINTENANCE.....	15
2.7.	INFORMATION AND SAFETY SIGNALS ...	16
2.8.	SURROUNDING AREAS .....	17
<b>3</b>	<b>TECHNICAL INFORMATION</b>	
3.1.	MACHINE GENERAL DESCRIPTION .....	18
3.2.	DESCRIPTION OF THE OPERATION CYCLE .....	20
3.3.	SAFETY DEVICE DESCRIPTIONS .....	22
3.4.	DESCRIPTION OF THE ELECTRICAL DEVICES.....	23
3.5.	PNEUMATIC DEVICE DESCRIPTION .....	24
3.6.	ACCESSORIES ON REQUEST.....	25
3.7.	TECHNICAL SPECIFICATIONS .....	27
3.8.	NOISE LEVEL .....	30
3.9.	INSTALLATION ENVIRONMENT CHARACTERISTICS .....	30
<b>4</b>	<b>INFORMATION ON HANDLING AND INSTALLATION OPERATIONS</b>	
4.1.	RECOMMENDATIONS FOR HANDLING AND LOADING .....	31
4.2.	PACKING .....	31
4.3.	TRANSPORT AND HANDLING .....	32
4.4.	HANDLING AND LIFTING.....	32
4.5.	MACHINE INSTALLATION.....	33
4.6.	FASTENING THE MACHINE .....	37
4.7.	SETTING THE MACHINE INTO THE GROUND .....	37
4.8.	RECOMMENDATIONS FOR CONNECTIONS .....	38
4.9.	PNEUMATIC CONNECTIONS.....	38
4.10.	ELECTRICAL CONNECTION .....	39
<b>5</b>	<b>INFORMATION ON ADJUSTMENTS</b>	
5.1.	RECOMMENDATIONS FOR ADJUSTMENTS .....	40
5.2.	ADJUSTING FILM "STRETCH" .....	40
5.3.	ABLE ROTATION CHAIN ADJUSTMENT ...	40
5.4.	REEL CARRIAGE LIFTING CHAIN ADJUSTMENT .....	41
5.5.	PRESSURE PLATEN HEIGHT ADJUSTMENT .....	41
5.6.	CLAMP CLOSING ADJUSTMENT .....	44
<b>6</b>	<b>ABOUT THE USE</b>	
6.1.	RECOMMENDATIONS FOR OPERATION AND USE .....	45
6.2.	CONTROL DESCRIPTION .....	46
6.3.	CYCLE PARAMETER SETTING.....	53
6.4.	WRAPPING CYCLE RESET .....	54
6.5.	MACHINE CONDITIONS .....	55
6.6.	MACHINE OPERATION PREPARATION....	55
6.7.	MACHINE STARTING.....	55
6.8.	CYCLE START .....	57
6.9.	TYPES OF STOPPING AND STARTING....	58
6.10.	REEL CARRIAGE MOVEMENT (MANUAL MODE) .....	59
6.11.	TABLE MANUAL ROTATION .....	59
6.12.	OPERATION OF THE ARM, PAD AND CLAMP UNITS .....	60
<b>7</b>	<b>MAINTENANCE INFORMATION</b>	
7.1.	MAINTENANCE INSTRUCTIONS .....	61
7.2.	MAINTENANCE PERIOD TABLE .....	62
7.3.	LUBRICATION POINT DIAGRAM.....	64
7.4.	LUBRICANTS TABLE .....	65
7.5.	DRAINING THE CONDENSATE.....	66
7.6.	CLEANING THE FILTER.....	66
7.7.	CLEANING MACHINE .....	67
<b>8</b>	<b>TROUBLESHOOTING</b>	
8.1.	ALARM MESSAGES.....	68
8.2.	LED CHECK.....	69

## TABLE OF CONTENTS

### **9 SPARE PARTS REPLACEMENT INFORMATION**

- 9.1. RECOMMENDATIONS FOR REPLACING PARTS ..... 71
- 9.2. REPLACING ROTATING TABLE WHEELS 72
- 9.3. REPLACEMENT OF THE CUTTING THREAD ..... 72
- 9.4. FUSE REPLACEMENT ..... 73
- 9.5. LIST OF ESSENTIAL SPARE PARTS..... 73
- 9.6. MACHINE DISPOSAL AND SCRAPING..... 74

### **10 ENCLOSED DOCUMENTATION**

- 10.1. PNEUMATIC CIRCUIT DIAGRAM ..... 75
- 10.2. WARRANTY CONDITIONS ..... 76

## GENERAL INFORMATION

### 1.1. PURPOSE OF THE MANUAL

- The manual is an integral part of the machine and is aimed to provide the operator the instructions for use in order to prevent and reduce the risks that arise from man-machine interface.

The information have been written by the manufacturer into Italian (the original language) in full compliance with the professional writing principles and the regulations in force.

The communication principles were chosen according to the target readers in order to ease the reading and understanding of the information.

The information may be translated into other languages to satisfy the legal and/or market requirements.

The manuals must be translated directly from the ORIGINAL INSTRUCTIONS, without modification.

Each translation (including that provided by the purchasing agent or by the company that introduces the machine into the country in question) must specify the message “Translation of the original instruction”.

- Keep this manual for the entire duration of its useful life in a well known and easy to access place, available for reference any time the need should arise.
- Refer to the table of contents and the analytical index in order to easily identify the subjects of interest.
- Some information may not correspond completely to the actual configuration of the machine delivered.
- Any additional information does not affect the readability of the text and the safety level.
- The manufacturer reserves the right to modify the contents of the manual without prior notice provided that the safety level is not altered.
- The symbols described below are used to highlight the most important information or specifications.



Indicates critically dangerous situations that if neglected can result in serious personal safety and health hazards.



Indicates that suitable actions must be employed in order to avoid personal safety and health hazards and economic damages.



Indicates particularly important technical information that should not be neglected.

GENERAL INFORMATION

**1.2. MANUFACTURER AND MACHINE IDENTIFICATION**

The illustrated identification plate is applied directly on the machine. It contains references and indispensable operating safety indications.

- A) Machine model.
- B) Machine's serial number.
- C) Year of manufacture.
- D) Mains voltage.
- E) Mains frequency.
- F) Number of phases.
- G) Absorption.
- H) Total installed power.
- I) Air consumption.
- L) Maximum pressure.
- M) Mass.
- P) Manufacturer and address.

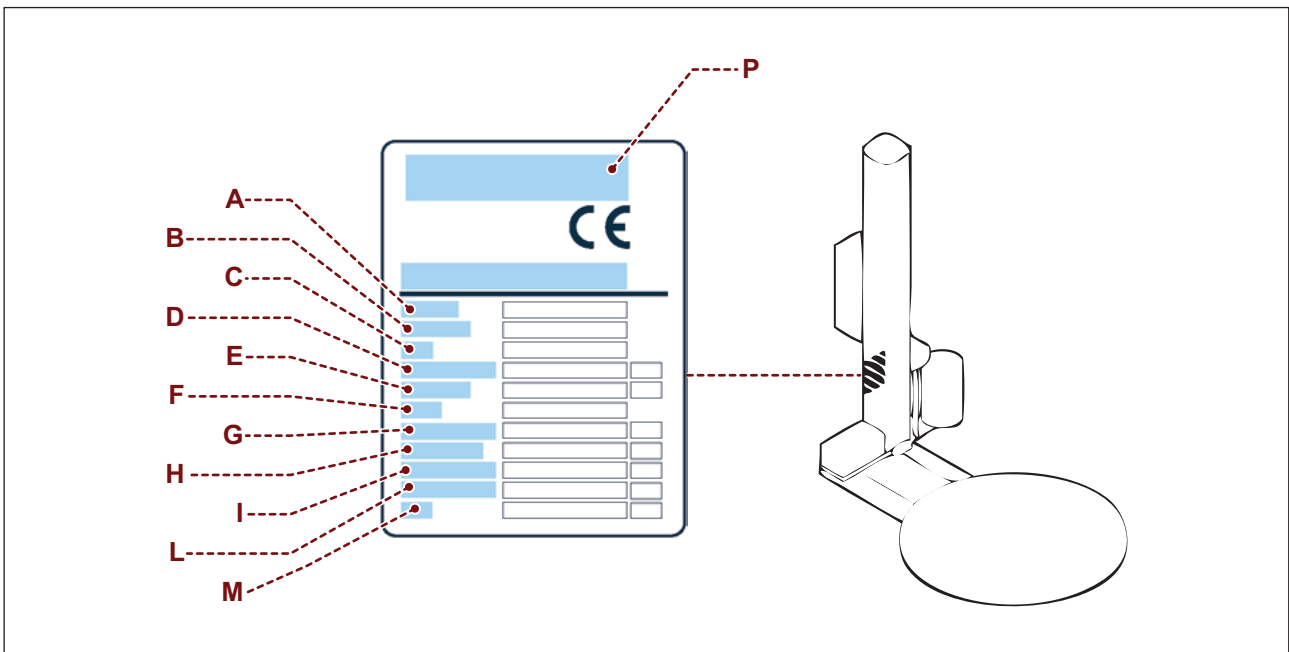

## GENERAL INFORMATION

### 1.3. TERMS AND DEFINITIONS

Some recurring terms found within the manual are described in order to provide a more complete image of their meanings.

- **Routine maintenance:** The set of operations that are required to keep the machine functional and efficient.  
These operations are usually programmed by the manufacturer, who establishes the necessary skills and the procedures for interventions.
- **Non-routine maintenance:** The set of operations that are required to keep the machine functional and efficient.  
These operations are not programmed by the manufacturer and must be carried out by the maintenance worker.
- **Operator:** A person authorised and chosen from those who have the requirements, skills and information necessary for installation, use and ordinary maintenance of the machine.
- **Maintenance technician:** Authorized technician who is chosen from among those who possess the requisites to carry out routine and extraordinary maintenance on the machine.  
He must as such have precise know-how and skills with special ability to carry out the interventions assigned.
- **Format Change:** series of operations to carry out on the machine before starting to work with the machine with different characteristics respect to the previous ones.
- **Training:** training process aimed to transfer to the operator the knowledge, skills and behaviour required to operate the machine autonomously, properly and safely.
- **Installer:** technician chosen, among those that meet the requisites, and authorised by the manufacturer or by its representative, to install and test the machine or the system in question.
- **Assistant:** employee assigned to assist the production processes of the machine or system in question.

### 1.4. MODES OF REQUESTING FOR ASSISTANCE

The distribution network ROBOPAC is at your service for any problem that requires technical support, to order spare parts, and for whatever new type of need that can help develop your business.

Report the data displayed on the ID plate, the estimated hours you have used the machine, and the type of flaw you have uncovered when requesting technical support.

Contact one of our authorized dealers at the listed address for all your needs.

**ROBOPAC SPA**

**VIA FABRIZIO DA MONTEBELLO, 81**

**47892 ACQUAVIVA GUALDICCILO, REPUBBLICA S. MARINO  
(RSM) Phone: 0549 (international ++378) 910511**

**Fax: 0549/908549 - 905946 <http://www.aetnagroup.com>**

GENERAL INFORMATION

**1.5. ATTACHED DOCUMENTATION**

The machine is provided with the documentation listed below, in the absence of a different trade agreement.

- Warranty conditions.
- Wiring diagram and list of components.
- Pneumatic circuit diagram.
- A hard copy of the "Use and maintenance instructions" in the language of the country of use.
- Manuals of installed commercial devices (if necessary for machine use).
- DVD containing the information listed below.
  - Use and maintenance manual translated into various languages.
  - Spare parts catalogue.

# SAFETY INFORMATION

### 2.1. GENERAL SAFETY PRECAUTIONS

- Carefully read the “Instructions for use” specified in the manual and those applied directly to the machine.  
It is important to dedicate a little time to read the “Instructions for use” in order to minimise the risks and avoid unpleasant accidents.
- Before performing any operation, the operator must make sure that he/she understood the “Instructions for use”.
- Pay attention to the SAFETY WARNINGS, do not use the machine for UNSPECIFIED PURPOSES and assess the possible RESIDUAL RISKS.
- Caution is essential.  
Safety is also in the hands of those who interface with the machine throughout its life span.

**Sometimes, accidents can be caused by a “careless” use of the machine by the operator.**

**Usually it is too late to remember what should have been done when the accident has already happened.**

- Preserve the readability of the information signs and observe the indications given.  
The information signs may have different shapes and colours, indicating hazards, obligations, prohibitions and information.
- The manufacturer has designed the machine observing all the “good manufacturing regulations” and the standards in force.  
The machine has been designed to be constructed and equipped with devices that ensure intrinsic safety.  
Tampering with the safety devices and the removal of the same may create risks (even severe) for the operators.
- The personnel authorised to carry out any operation with the machine must have acknowledged experience in the specific field.
- **The manufacturer is not responsible for any damage to the product delivered in the package during the wrapping and stabilisation and the following operation phases.**

**Non compliance with the instructions given may cause risks for safety and health of the persons and economic damages.**

SAFETY INFORMATION

**2.2. SAFETY WARNINGS FOR HANDLING AND INSTALLATION**

- The personnel authorised to handle the machine (loading and unloading) must possess particular expertise in the field of intervention.
- Handle (load and unload) the machine according to the instructions affixed directly to the machine, to the package and those in the user manual.
- Have helpers aid you when handling the machine if the conditions require added assistance.  
This may entail unexpected risks.  
In order to minimise the risks related to assistants' involvement, you must inform them priorly on the type of work and the behaviour to be used.
- The machine must be handled with the aid of specific means (crane, forklift etc.) by qualified personnel capable of observing the safety requirements.
- When using the lifting means, insert and/or fasten the devices (hooks, forks etc.) ONLY into the points provided on the package and/or the machine.
- Transport the machine suitable means of adequate capacity.
- Make sure the machine and its components are properly fastened to the transport mean.  
Check the machine dimensions and affix proper signs if the machine overall dimensions exceed the values allowed by road regulations.
- The minimum and maximum temperature (during transport and/or storage) must fall within the range allowed in order to prevent damaging the electrical components.
- Install the machine ONLY in spaces free of explosion and /or fire risks.  
Avoid the spaces exposed to atmospheric and corrosive agents.
- Assess, prior to installation, if it is necessary to draw up a "safety plan" in order to protect the safety of the personnel involved.
- Provide proper safety conditions when operating at high altitudes areas that are dangerous and hard to access.
- Install the machine according to the minimum perimeter indicated by the manufacturer and the surrounding activities.
- Should the machine interface directly/indirectly with other machines or production lines, draw up the installation design of the machine.  
The design must include all the operating conditions in order to comply with the standards in force on safety at work place.
- Check that the installation space is properly ventilated in order to avoid air concentration unhealthy for the operators.
- Apply the most suitable solutions for reducing the noise levels and the acoustic pollution to minimum.
- Carry out the electrical connections professionally and in full compliance with the instructions provided by the manufacturer and the specific regulations in force.

**The electrical connections must be carried out EXCLUSIVELY by operators with particular expertise in the field of intervention.**

## SAFETY INFORMATION

- The operator must test the machine and check, through a general test, that the machine can be commissioned without any risk for the operator.
- Dismantle all the packaging components in compliance with the standards in force in the country of installation.

**Non compliance with the instructions given may cause risks for safety and health of the persons and economic damages.**

### 2.3. SAFETY WARNINGS FOR USE AND OPERATION

- The operator must be trained and possess the proper knowledge required to carry out the specific tasks and must meet the conditions required for the safe use of the machine.
- When using the machine for the first time, the operator must read the manual and identify the controls and simulate some operations, especially the start-up and shutdown.
- The machinery has been designed and manufactured to satisfy all the operating conditions indicated by the manufacturer.

**Use the machine ONLY with the original safety devices installed by the manufacturer.**

**DO NOT tamper with, remove or bypass the safety devices installed on the machine.**

- DO NOT modify the constructive and functional characteristics of the machine.
- Do not use the machinery with the safety devices not properly installed and efficient.
- ALWAYS wear the individual safety devices indicated in the “Instructions for use” and provided by the standards in force regarding the safety at workplace.
- ALWAYS keep the surrounding areas in suitable conditions and free of obstacles in order to minimise the risks, especially near the control station.
- The machine must be used by one operator ONLY, that must be assigned and authorised by the employer.
- The involvement of one or more assistants when performing some operations or maintenance (ordinary) interventions may present unpredictable risks.  
In order to minimise the risks related to assistants’ involvement, you must inform them priorly on the type of work and the behaviour to be used.
- Make sure that no foreign persons are present within the machine operating area during its production activity and maintenance.

**Non compliance with the instructions given may cause risks for safety and health of the persons and economic damages.**

SAFETY INFORMATION

**2.4. SAFETY WARNINGS RELATED TO INCORRECT USE**

**Incorrect use that can be reasonably expected**

- The predictable incorrect use consists of: “**the use of the machine different from the indications given in the manual, that may stem from the easily predictable human behaviour**”.

**The machine must be used ONLY for wrapping and stabilising products with regular shape or with a shape that ensure a stable wrapping.**

**The packs that contain liquids or insubstantial materials must be suitable for the product and must be perfectly closed and tight in order to prevent any leaks of the content.**

DO NOT wrap or palletize products in packaging (boxes, containers for liquids, etc...) with an irregular form or one that does NOT guarantee their stability.

- The machine must be used ONLY for the uses intended by the manufacturer.
- DO NOT allow the machine to be used by operators that are not properly trained, informed and unauthorised.
- Packages that contain liquid or inconsistent products must ensure that they do not leak.
- DO NOT wrap products that are loose, that have an irregular shape or that are not suitably collected, to prevent inadequate palletisation.
- Do not use the machine to wrap and stabilise living beings (animals and humans).
- DO NOT use the machine with wrapping material different from that provided by the manufacturer.
- Do not use the machine as a lifting device or as a rest surface for work activities (for example, a workbench).
- Do not over stretch or pre-stretch the film and do not wrap with an excessive number of bindings in order to prevent damaging the packages and products contained inside.
- DO NOT use or let the machine be used for purposes or in ways not provided by the manufacturer.
- DO NOT use or make use of machines with defective, deactivated and/or not perfectly installed safety devices.
- DO NOT continue to use the machine if malfunctions have been detected.  
Stop the machine immediately and restart it only after the normal conditions of use have been restored.
- NEVER carry out an intervention with the machine enabled but ONLY after having stopped it properly, under safety conditions.
- NEVER use the machine without wearing the Personal Protective Devices indicated by the manufacturer and required by current workplace laws.
- NEVER use the machine if the scheduled maintenance interventions have not been carried out accordingly.

## SAFETY INFORMATION

- DO NOT clean or wash the machine with aggressive products to avoid damaging the components.
- DO NOT replace the components with non-original spare parts or with different design and constructive features.
- DO NOT leave the machine unattended at the end of the work without shutting it down first in safety conditions.

### **Employer obligations**

- The operator must be trained to acquire the skills required for the packaging machine or an equivalent machine.  
Upon completion of training, make sure the operator has understood the contents in the use manual, especially the information regarding safety.
- The operator must possess the required training and meet the suitable conditions for carrying out the activities in safety conditions.
- The employer must inform the operator on the INCORRECT USES predictable and on the persistent Residual risks.
- The operator must be capable of reading and understanding the user manual and must easily identify the safety signs.
- Make sure the machine is ONLY used by adequately trained, documented and authorized operators.

**The employer must draw up the documentation of the specific training carried out by the operators in order to exhibit it in case of litigation.**

SAFETY INFORMATION

**2.5. SAFETY WARNINGS ON RESIDUAL RISKS**

When designing and building the machine, the manufacturer has paid particular attention to the RESIDUAL RISKS that may affect the safety and health of the operators.

The residual risks are: **“all the risks that persists although all safety solutions have been applied and integrated during machine design”**.

The manufacturer has complied with the specific standards in force and applied all the “good manufacturing regulations”.

The purpose of this information is to make the user aware to pay special attention in order to foresee any risk.

There is no substitute for carefulness.

Safety also lies in the hands of all operators that work on the machinery.

The list specifies the residual risks specific for this type of machine.

- **Danger of collision and slipping:**  
Do not approach or climb on machine parts when operating.

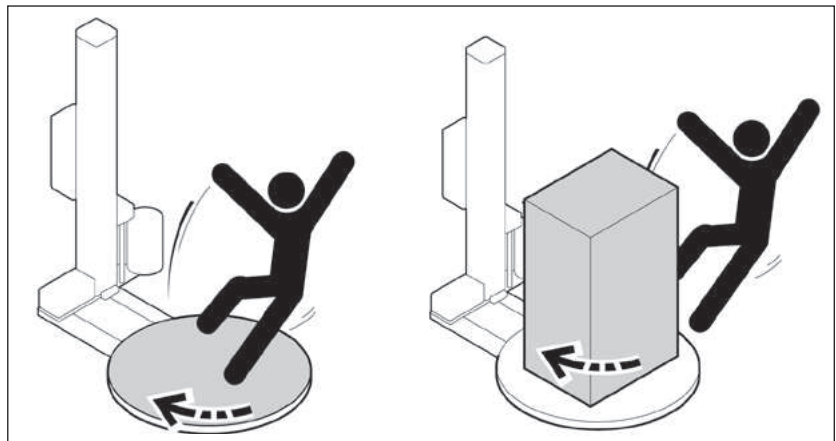

- **Upper limb cutting hazard:**  
Do not place hands inside components in motion.

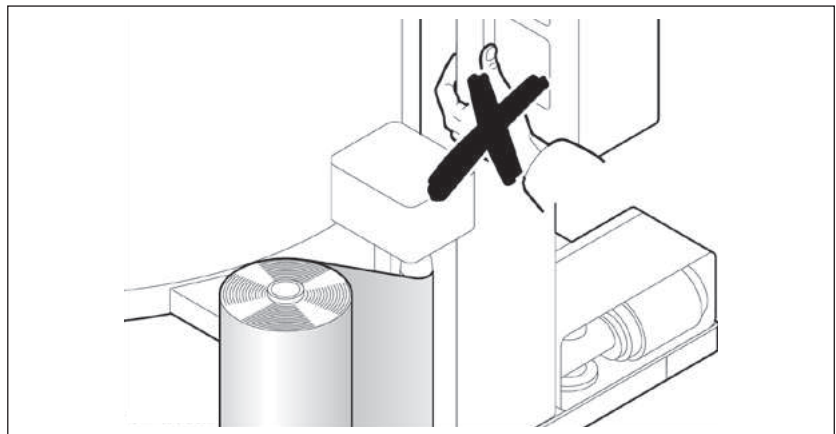

SAFETY INFORMATION

- **Body crushing hazard:** Do not linger in the machine operating area.

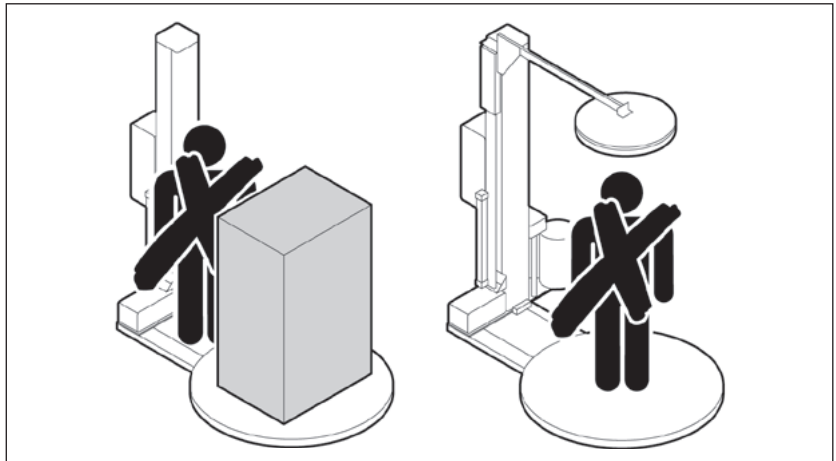

- **Danger of arms crushing:** Do not put hands inside the clamp unit.

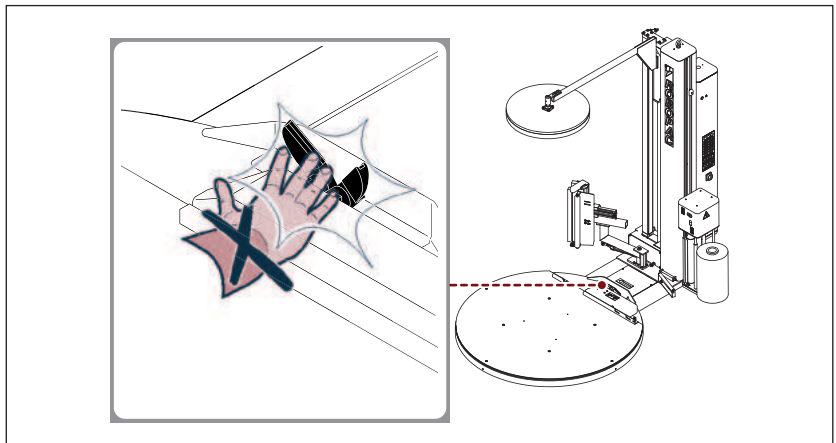

- **Danger of scalding/burning:** Never bring body parts close to the rotating arm unit and especially to the cutting line and sealers (only for CW).

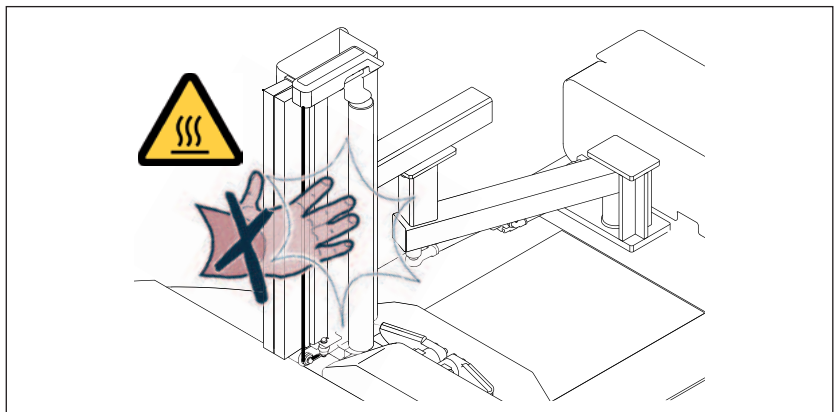

SAFETY INFORMATION

- **Danger of collision and slipping:** Do not draw close to or climb onto machine parts (i.e. the turntable) with the lifting device while the machine is running.
- **Danger of projecting or falling objects** Do not use the machine at a speed that is not appropriate for the product you need to wrap. If the packages you need to wrap contain unstable or hazardous elements, you must adopt suitable safety precautions (i.e. perimeter guards) to prevent the risk of harming the physical wellbeing of personnel.

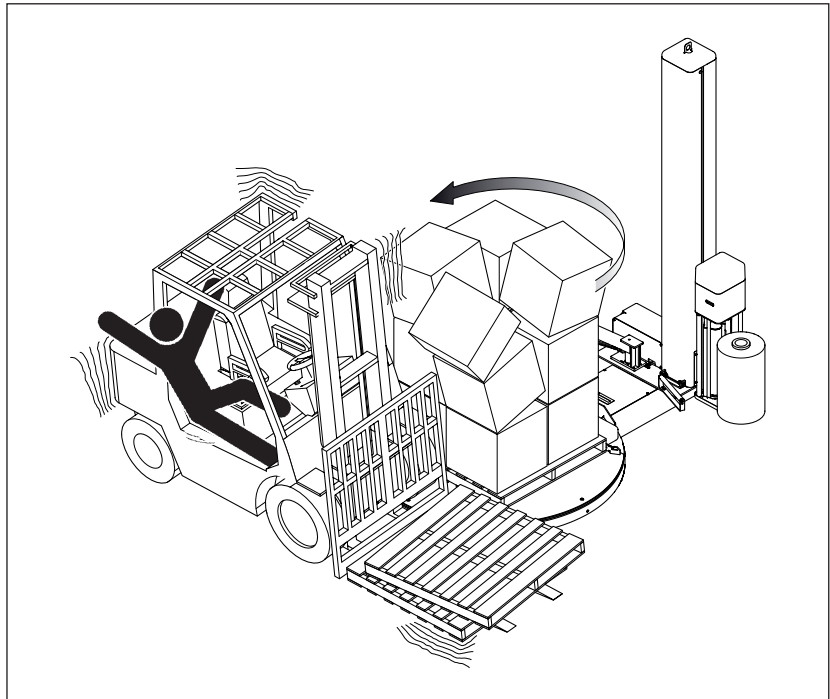

SAFETY INFORMATION

**2.6. SAFETY WARNINGS FOR REGULATIONS AND MAINTENANCE**

- Keep the machinery in maximum efficiency condition and perform all the scheduled maintenance operations provided for by the manufacturer.  
Proper maintenance will provide the best performance, a longer life span and constant compliance with safety requirements.
- Enable all machine safety devices before performing any maintenance and regulation operations.
- Delimitate the work area complying with the safety conditions as provided by the standards on workplace safety in order to minimise the risks.
- The maintenance interventions in the areas that are not easily accessible or dangerous must be carried out after having ensured the necessary conditions.
- The personnel authorised to carry out the ordinary maintenance (regulations, replacements etc.) must possess the necessary technical and professional knowledge.
- DO NOT carry out interventions different from those indicated in the user manual without the written consent of the manufacturer.
- DO NOT use products that contain corrosive, toxic and inflammable substances.
- Wear the Individual Protection Devices provided by the laws on workplace safety and indicated in the “Instructions for use” and/or affixed to the machine.
- Replace the components ONLY with ORIGINAL PARE PARTS or with SIMILAR design and functional features.  
The use of similar but non-original spare parts may lead to improper repairs, altered performance and economic damage.

**The components and/or safety devices shall be replaces ONLY with original spare parts to avoid altering the provided safety level.**

- Use lubricants (oils or grease) recommended by the manufacturer or with similar chemical-physical features.
- Do not dump into the environment polluting liquids, worn parts and maintenance waste.  
Dispose of the same in compliance with current regulations on the matter.
- Select the components according to the chemical and physical features of the material and carry out the differentiated waste disposal as per the standards in force.
- All the extraordinary maintenance interventions shall be carried out EXCLUSIVELY by authorised personnel with particular expertise in the field of intervention.

**Non compliance with the instructions given may cause risks for safety and health of the persons and economic damages.**

SAFETY INFORMATION

**2.7. INFORMATION AND SAFETY SIGNALS**

The figure indicates the position of the safety and information signs affixed to the machine.

For each sign is specified the relative description.

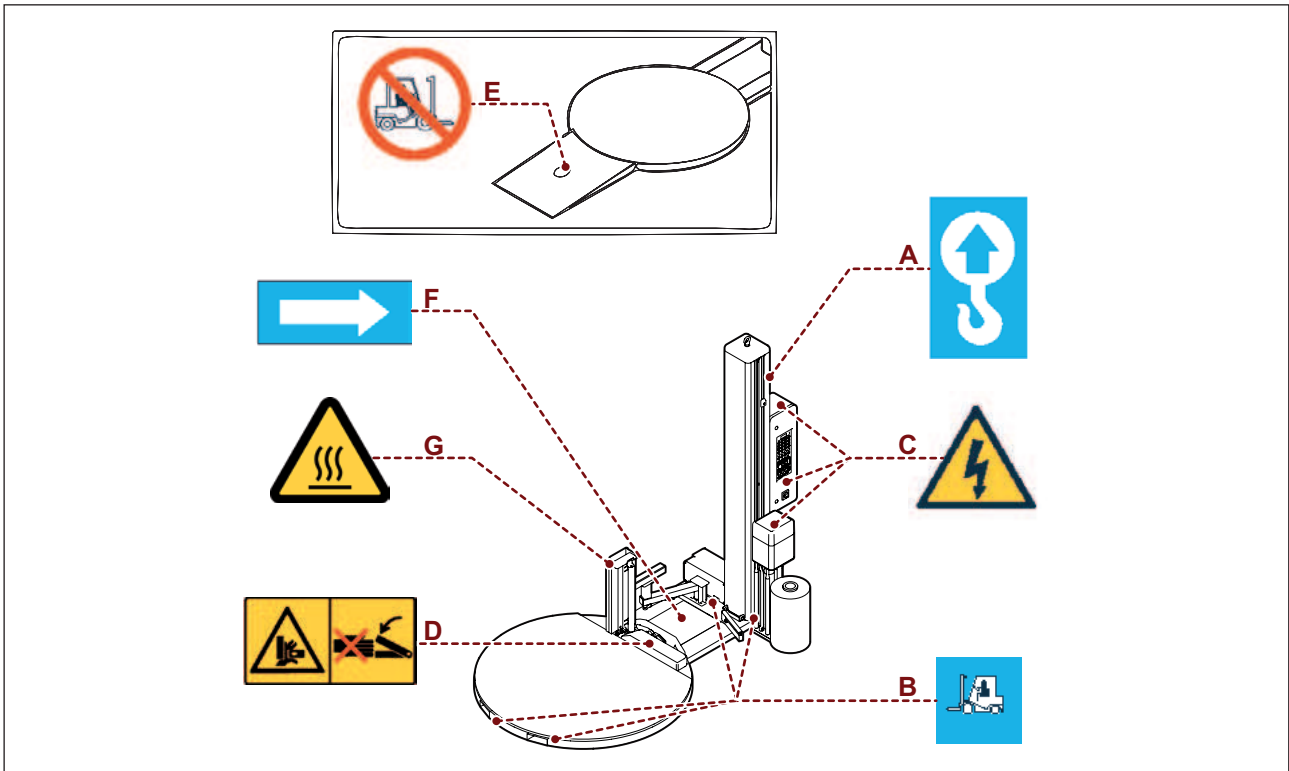

- A) Information sign**  
Indicates the points for lifting with a hook device.
- B) Information sign**  
It shows the insertion points for the lifting forks.
- C) Electrical hazard sign**  
Do not access this area: risk of electrical shock or electrocution.
- D) Hazard sign**  
Danger of arms crushing.
- E) Prohibition sign**  
Do not climb onto the ramp with the forklift.
- F) Information sign**  
Indicates the direction in which the turntable rotates.
- G) Hazard sign**  
Danger of high temperature.



**Important**

**Make sure the labels are clearly readable.**

**If they are not, replace them and fit them onto the machine where they originally were.**

SAFETY INFORMATION

**2.8. SURROUNDING AREAS**

The illustration depicts the perimeter work areas of the machine.

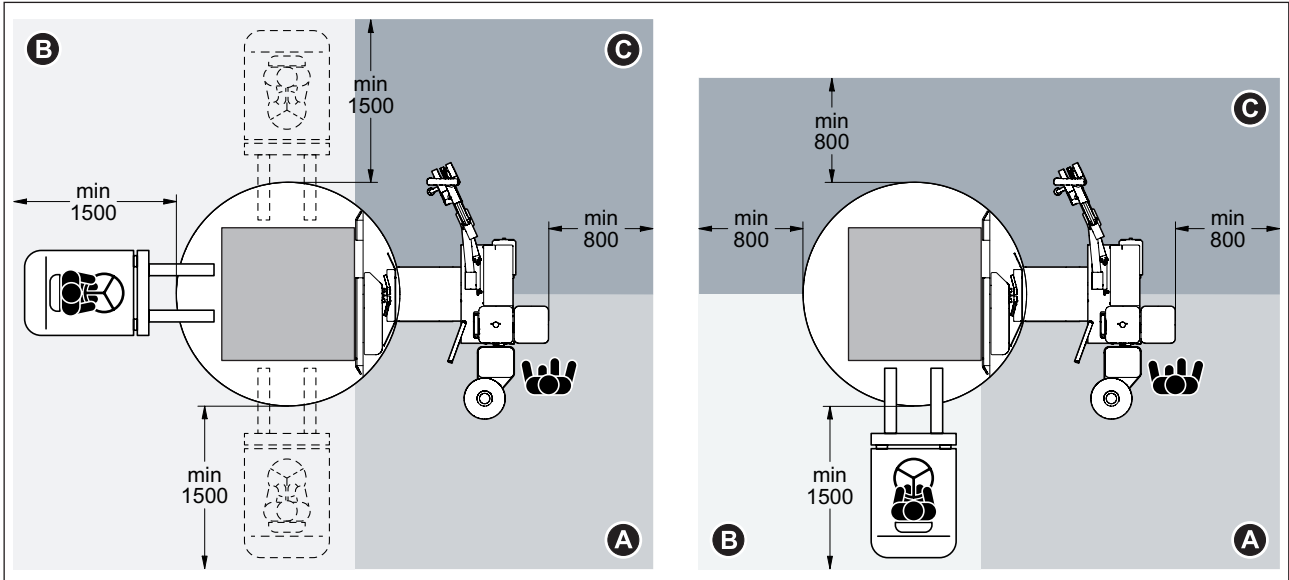

- A) Operator's working area
- B) Pallet loading/unloading area
- C) Surrounding area

## TECHNICAL INFORMATION

### 3.1. MACHINE GENERAL DESCRIPTION

Automatic machine for wrapping and stabilizing palletised loads with stretch film.

The loads are wrapped using reels of stretchable film which can be readily found on sale.

The machine consists of a turntable that makes the pallet rotate, by a reel carriage that unwinds and stretches film, by a film cutting unit and a film clamping unit for film holding at the end of the wrapping cycle.

The machine is equipped with a series of safety devices designed to avoid any harm befalling the operator or other persons who come into contact with the machine in any way.

The machine must be **EXCLUSIVELY** used in order to wrap and stabilise products contained in packs (boxes, containers for liquids, etc.), having a regular shape or a shape that allows for stable palletising.

The packs that contain liquids or insubstantial materials must be suitable for the product and must be perfectly closed and tight in order to prevent any leaks of the content.

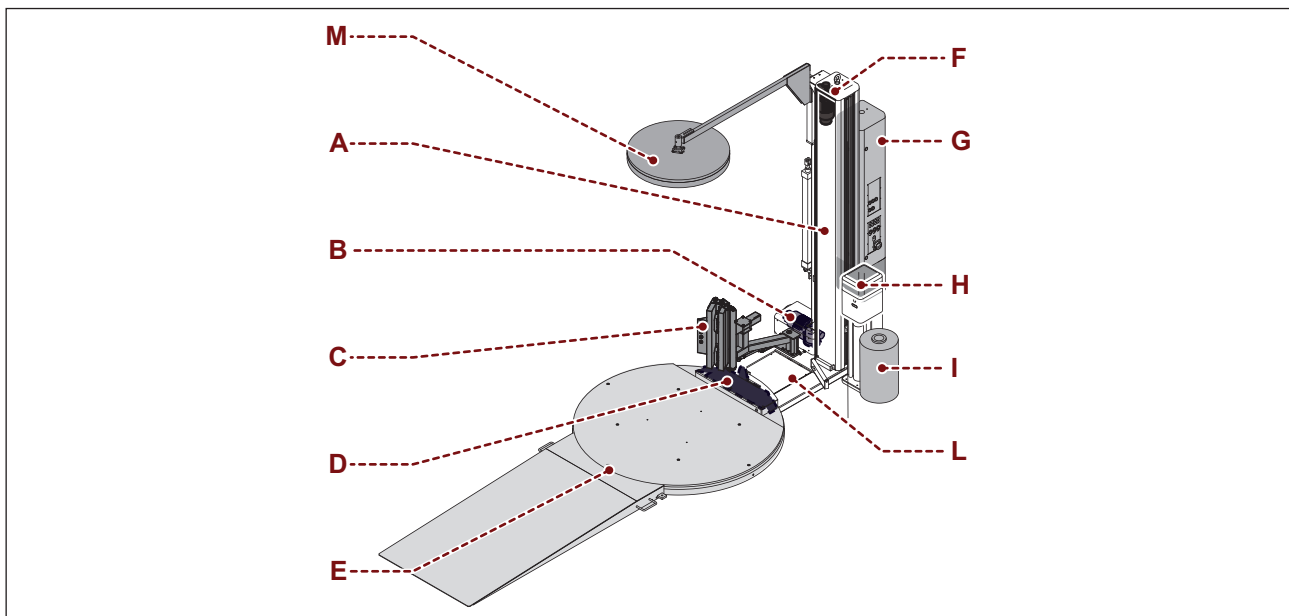

**A) Slide guide mast**

Allows the reel carriage to slide in order to wrap pallets with a maximum height of 2200 mm.

**B) Table drive**

Makes the turntable rotate by means of the engine.

**C) Arm unit**

Makes the sealing and cutting unit move.

**D) Clamp unit**

Allows the operator to stop the film when the wrapping cycle has been completed.

TECHNICAL INFORMATION

- E) Rotating table**  
Rotates the product that the machine has been programmed to wrap.
- F) Carriage drive**  
Moves the film carriage by means of the engine.
- G) Control panel**  
Enables machine functions.
- H) Pneumatic unit**  
Moves the clamp and cutting/sealing arm.
- I) Reel carriage**  
It is comprised of a reel support that moves vertically to wrap the product.
- L) Base**  
The main structure of the machine.
- M) Pressure platen (Optional)**  
Pneumatically controlled device to stabilise load. It can be furnished with a rod.  
Can be supplied with a pneumatic cylinder with rod (max. travel 800 mm) or without rod (travel same as the length of the sliding shaft).  
With the first type of cylinder, you will have to adjust the height based on the size of the product to be wrapped by the machine.  
No adjustment is instead required with the second cylinder.

According to the different operating requirements, this machine can be supplied in different models and configurations.

- **Technoplat 307 CW-CS with film carriage type “FR”:** frictioned roller, electromagnetic brake and film prestretch value adjustable from control panel.
- **Technoplat 507 CW-CS with film carriage type “PDS”:** Powered pre-stretch rollers and electronically controlled film tensioning. Possibility of selecting either fixed or variable pre-stretching mode. Pre-stretch is adjustable from control panel from 0% to 250%.
- **Technoplat 707 CW-CS with film carriage “PVS”:** Double-powered pre-stretch rollers and electronically controlled film tensioning. The operator can adjust the pre-stretch on the control panel from 0% to 400%.

The version CS does not include a sealing phase: the rotating arm unit only houses the cutting line.

Version CS uses film with adhesive.



**This machine is normally installed in workshops or industrial environments protected from the atmospheric agents.**

**Use of this machine in explosive environments or when exposed to the elements is strictly forbidden.**

During the operating stages, just one operator is necessary for pallet unloading and loading operations and reel change.

TECHNICAL INFORMATION

**3.2. DESCRIPTION OF THE OPERATION CYCLE**

**Phase 1**

- The pallet is loaded onto the turntable all the way to the end of the bracket on the plate, and the operator wraps the end of the film in the eyelet of the limit stop bracket.



**Caution Warning**

**Danger of arms crushing: Do not insert the film in the clamping unit by hand.**

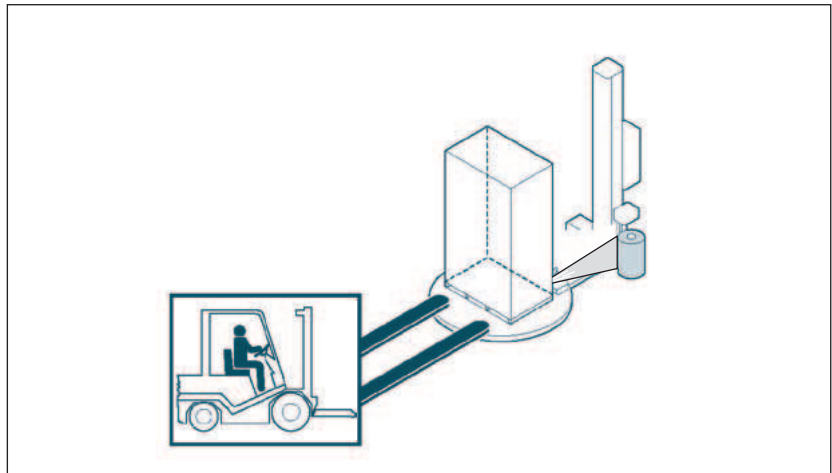

**Phase 2**

- Once the cycle has started, the turntable starts turning, while the film carriage unwraps the film based on the preset parameters.

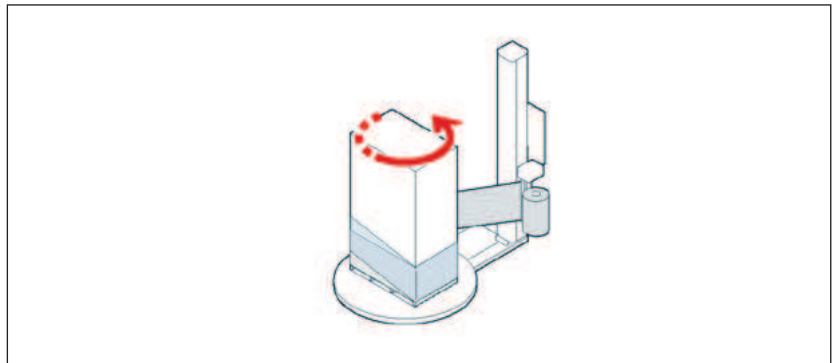

**Phase 3**

- When the wrapping phase is over, the machine stops and automatically hot-cuts and seals the film (CW version)
- The operator removes the pallet.
- The cycle ends and the machine is ready to start a new one.

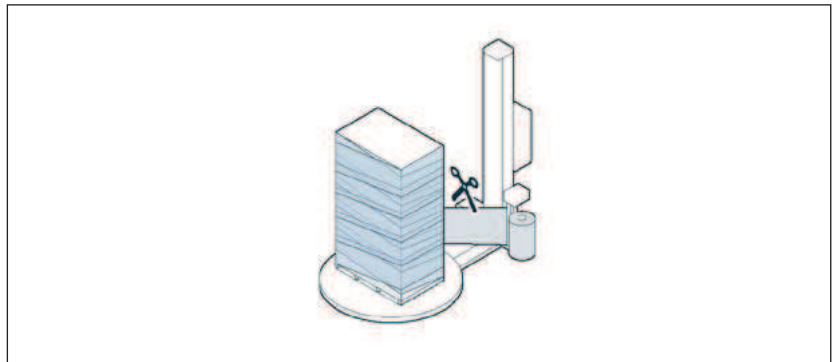

**Double wrapping cycle**

1. The reel carriage moves off from the bottom of the pallet and stops when it gets to the top, and then comes back down to the bottom of the pallet again, wrapping the load twice in doing so.

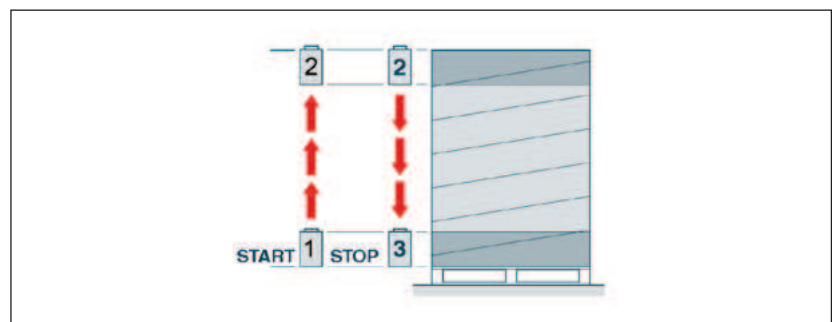

## TECHNICAL INFORMATION

**Wrapping cycle with feeder**

1. To select this cycle, press button **(P)**.

The corresponding led comes on (see chapters "Description of (green) buttons for cycle selection" and "6.3.Cycle parameter setting"). The machine performs a cycle which is aimed at facilitating the coverage of the pallet by the operator, and which guarantees the highest degree of protection possible.

The film carriage ascends all the way to the top end of the load and descends again for about 300 mm, stopping in this position. If the machine is fitted with a top pressure platen, this lifts from the load by about 200 mm

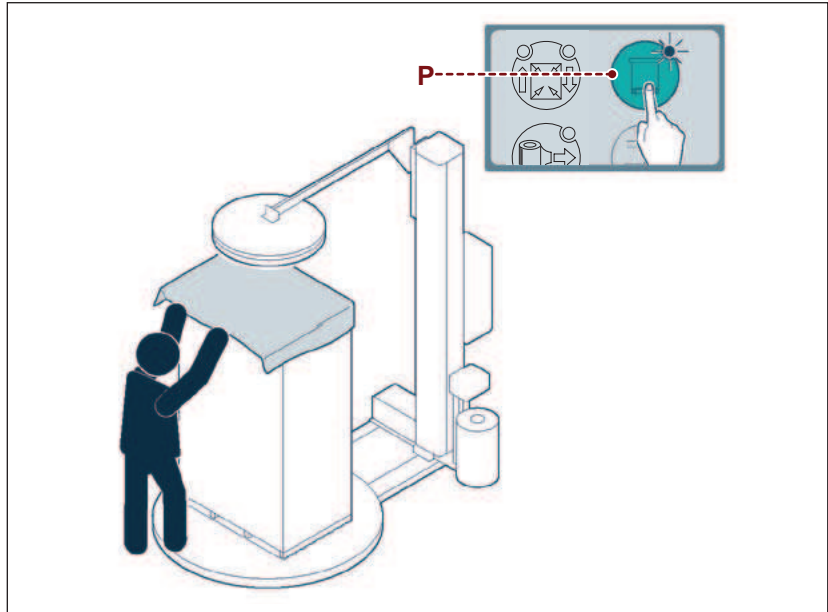

2. At this point, after having placed the covering sheet on the top portion of the pallet, the operator restarts the cycle by pressing the "start" button.

The clamp descends again.

The carriage rises again until it reaches the top of the pallet, performs the set number of upper wrappings of the pallet, then descends once more, thus completing the cycle.

This way, the top sheet position, securely held by the rising and lowering film wraps, is the best way to guarantee excellent load protection from external elements (water, dust, etc).

**Description of the "America cycle"**

1. To select the "America cycle", press **(5)** button and check for lighting of the proper Led.

The spool carriage starts from the base of the pallet and goes up to the top where it performs the preset reinforcing wraps.

The carriage then lowers to perform the bottom stabilizing wraps only at the end of the wrapping cycle.

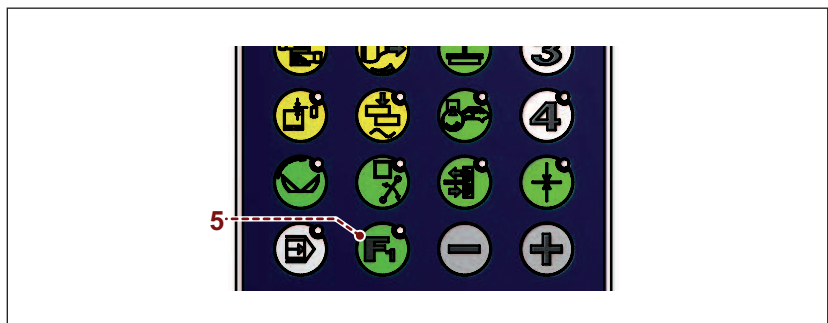

TECHNICAL INFORMATION

**3.3. SAFETY DEVICE DESCRIPTIONS**



**Danger  
Warning**

The safety devices must be periodically checked to ensure that they are working properly.

The machine is equipped with safety devices designed to guarantee the greatest possible degree of safety and protection for the operator.

**A) Micro-switch on film carriage base plate:**

Stops descent when there are obstacles beneath the carriage.

**B) Mechanical device to lock the film carriage:**

Immediately stops the fall of the film carriage if the lifting chain accidentally breaks.

**C) General switch:**

turns the electric power supply on and off.

It can be padlocked to prevent unauthorised personnel from starting the machine during adjustments and maintenance.

**D) Acoustic signal:**

Indicates wrapping cycle start.

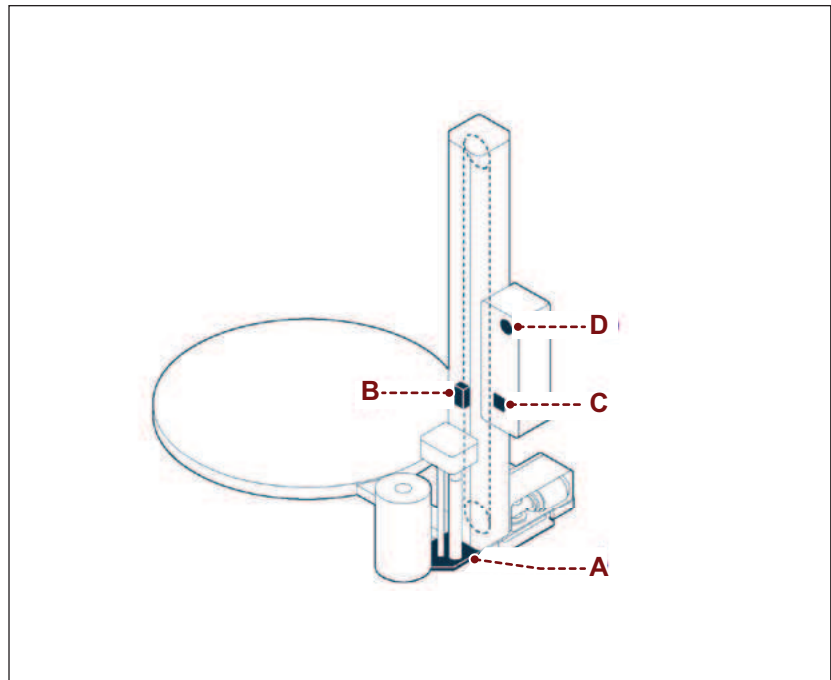

## TECHNICAL INFORMATION

**3.4. DESCRIPTION OF THE ELECTRICAL DEVICES**

The figure shows the positioning of the devices on board of the machine.

**A) Photocell:**

To detect the height and presence of the load to be wrapped.

**B) Carriage limit stop microswitch:**

Activates when the reel carriage reaches the minimum and maximum wrapping height.

**C) Sensor:**

Detects the “open” position of the arm.

**D) Geared motor:**

Enables rotation of the turntable.

**E) Geared motor:**

Enables movement of the film carriage.

**F) Microswitch:**

Stops its descent if there are obstacles beneath the film carriage.

**G) Microswitch:**

Stops the turntable in sequence.

**H) “Loading cell” sensor:**

Detects film tension and enables a speed variation of the pre-stretch rollers.

**I) Electrical motor:**

Activates the pre-stretch rollers.

**L) Remote control:**

to start and stop the wrapping cycle.

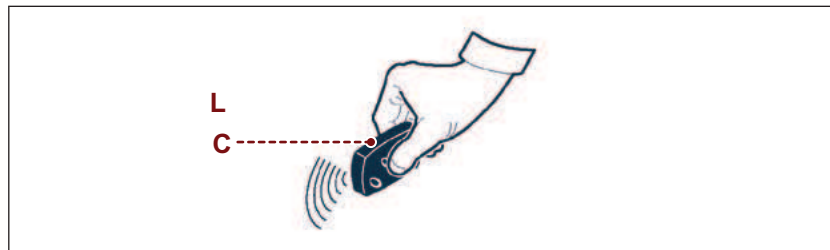
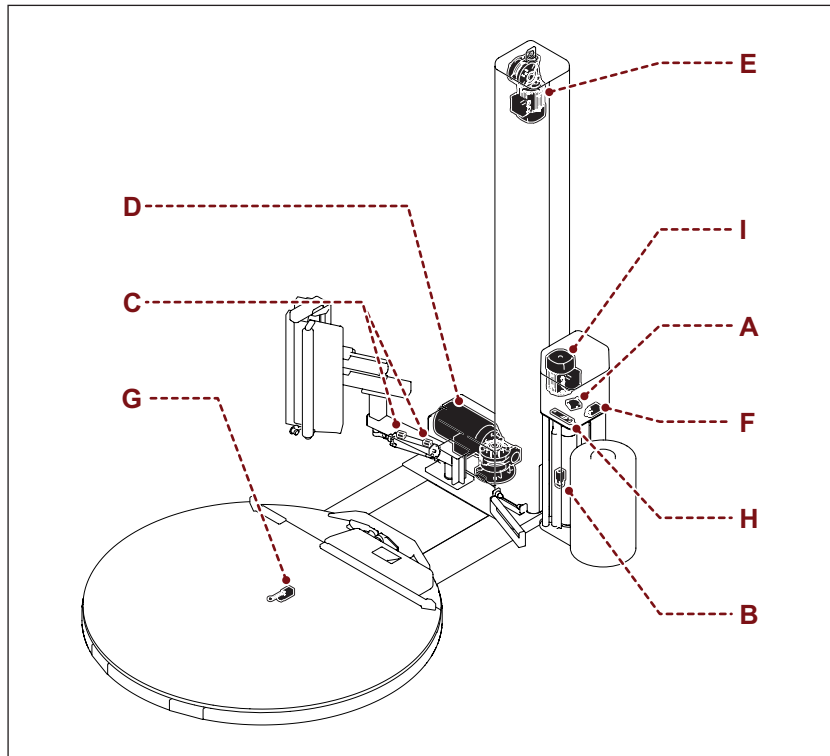
**Important**

For further details see the electrical diagram.

TECHNICAL INFORMATION

**3.5. PNEUMATIC DEVICE DESCRIPTION**

The figure shows the positioning of the devices on board of the machine.

- 1) **Tap:**  
to eliminate pneumatic pressure inside the machine.
- 2) **Pressure regulator with filter and pressure gauge:**  
to adjust general pressure of the pneumatic plant.  
Turn knob to change the pressure values indicated on the pressure gauge.
- 3) **Solenoid valve:**  
to eliminate pneumatic pressure inside the machine in case of an emergency stop.

 **Important**  
For further details see the pneumatic diagram.

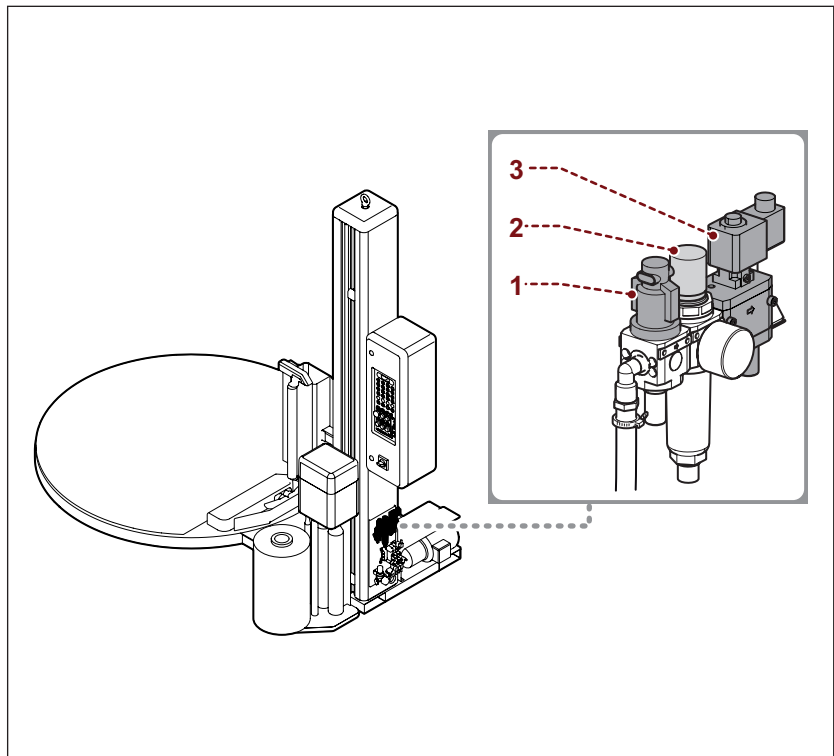

## TECHNICAL INFORMATION

**3.6. ACCESSORIES ON REQUEST**

To enhance the performance and to increase the versatility of the machine, the manufacturer furnishes the accessories listed below.

- **Pneumatic pressure platen (A)**

Pneumatically controlled device to stabilise load. It can be furnished with a rod.

Can be supplied with a pneumatic cylinder with rod (max. travel **800 mm**) or without rod (travel same as the length of the sliding shaft). With the first type of cylinder, you will have to adjust the height based on the size of the product to be wrapped by the machine. No adjustment is instead required with the second cylinder.

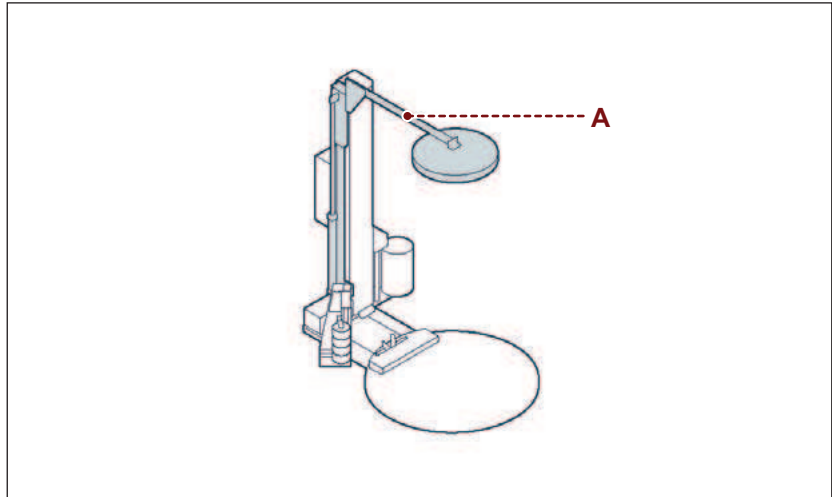

- **Pallet loading/unloading ramp (B)**

Facilitates these operations by means of forklifting devices (Manual pallet jack).

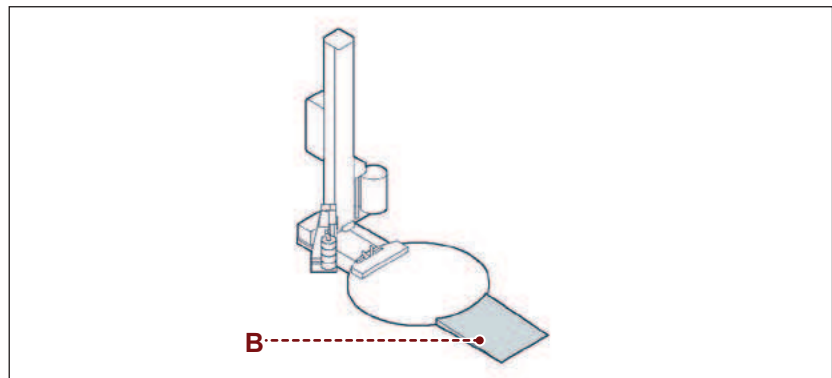

- **Additional remote control (C)**

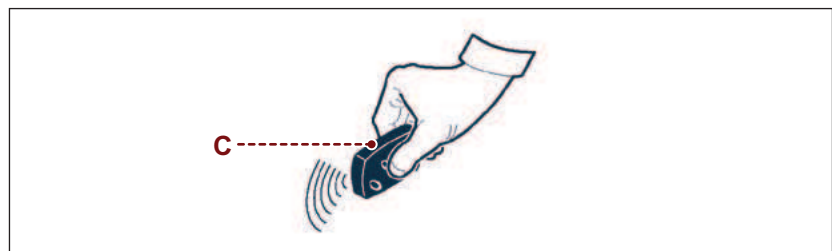

- **Slide guide mast (2400, 2800, 3100 mm)**  
to wrap taller than standard loads.

- **Start chain**  
to start the wrapping cycle.

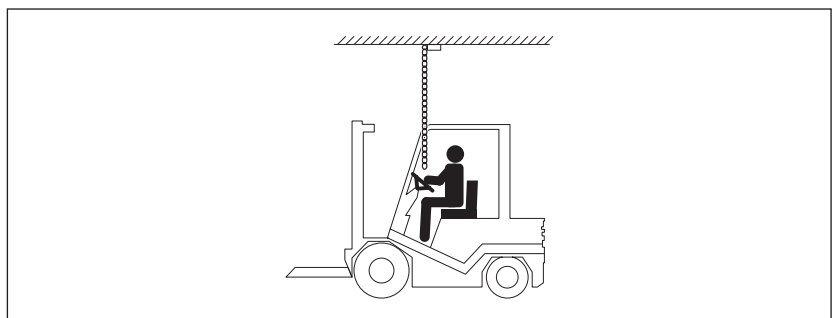

TECHNICAL INFORMATION

– **Photoeye that reads transit of black products (D)**

Detects the height and presence of dark-colored loads that the machine is programmed to wrap.

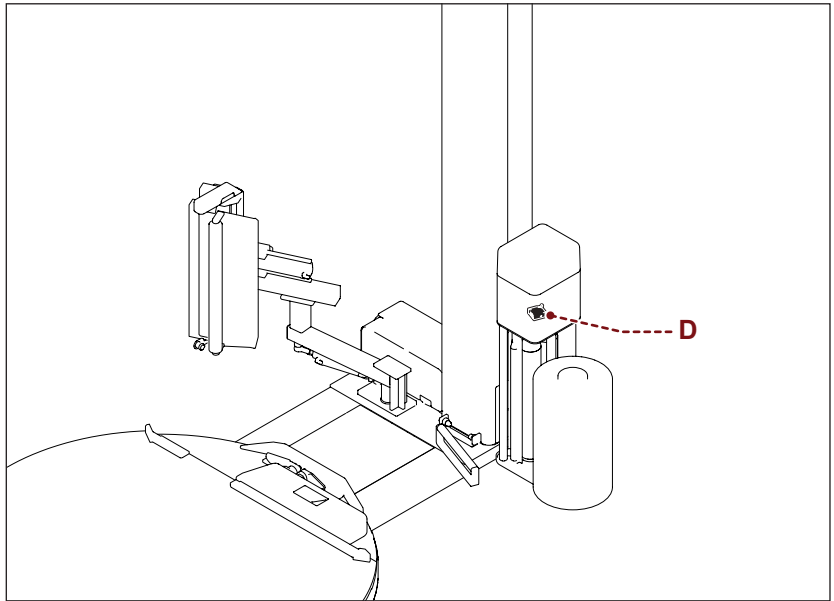

– **Perimeter protections**

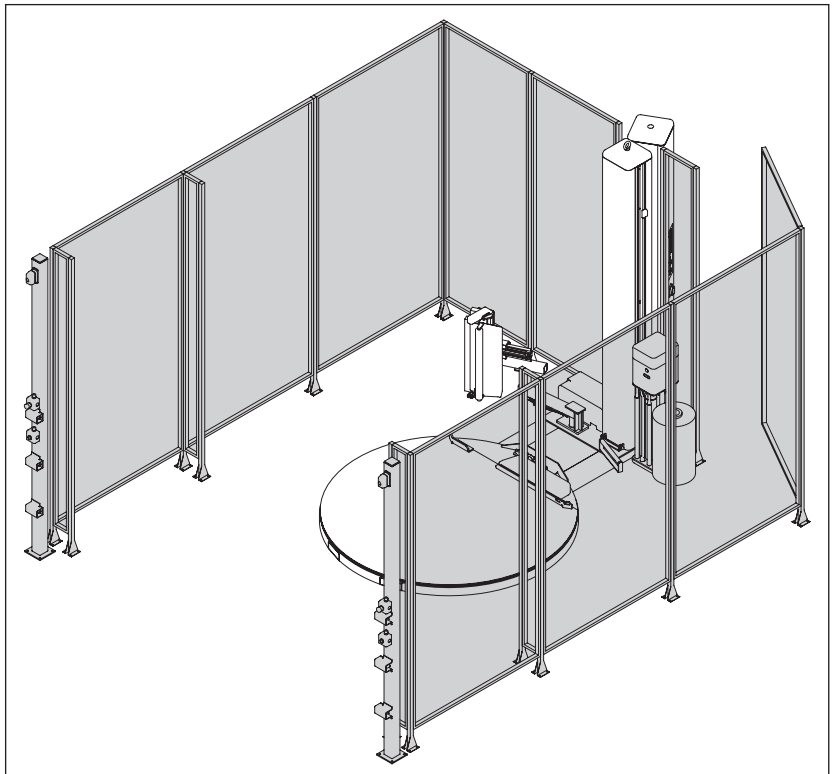

– **Rotating turntable with capacity 2500 kg**

Loads products up to 2500 kg.

– **Rotating table Ø 1800**

Its purpose is to wrap pallets that are larger than the standard size.

– **Film spool shaft Ø 50 mm**

– **Underground template**

Precisely shaped structure to set the machine base in the ground.

## TECHNICAL INFORMATION

**3.7. TECHNICAL SPECIFICATIONS**

Description	Units of measurement	Value					
		307		507		707	
Machine		CW	CS	CW	CS	CW	CS
Supply voltage		230V 1Ph + N 50/60 Hz					
Installed power	kW	2,5	2	3,1	2,6	3,7	3,2
Table rotational speed Ø 1650	rpm	12					
Table rotational speed Ø 1800		11					
Adjustable carriage up/down speed (Optional)	m/min	1÷4					
Table diameter	mm	1800-1650					
Max: load.	kg	2000					
Total weight	kg	600÷760					
Air consumption	NI/min	4	3	4	3	4	3

**Pressure platen (Optional)**

Description	Units of measurement	Value			
		H2200	H2400	H2800	H3100
Operating pressure	bar MPa	6(±1) 0.6 (±0.1)			
Rod cylinder stroke	mm	800			
Air consumption	NI/min	6			
No rod cylinder		H2200	H2400	H2800	H3100
No rod cylinder stroke	mm	1800	2000	2400	2700
Air consumption	NI/min	14	16	19	21

TECHNICAL INFORMATION

Reel dimensions

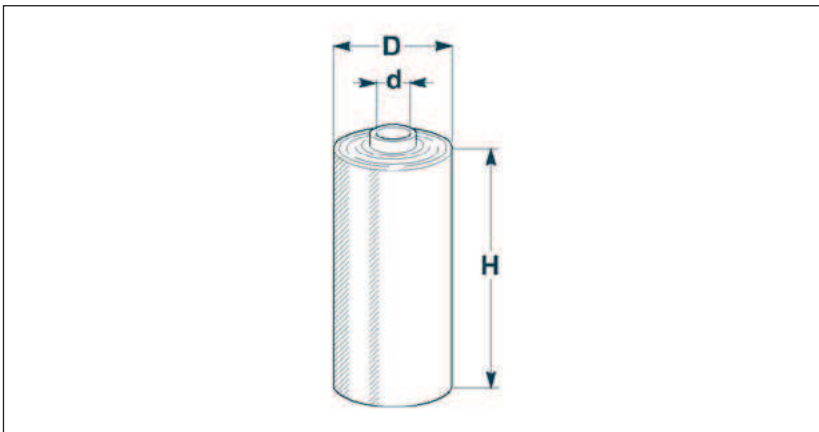

Description		Units of measurement	Value
D)	External diameter	mm	300
H)	Film reel height	mm	500
	Film thickness	μ	17÷35
d)	Internal diameter	mm	∅ 76
	Max weight	kg	~20

Product size

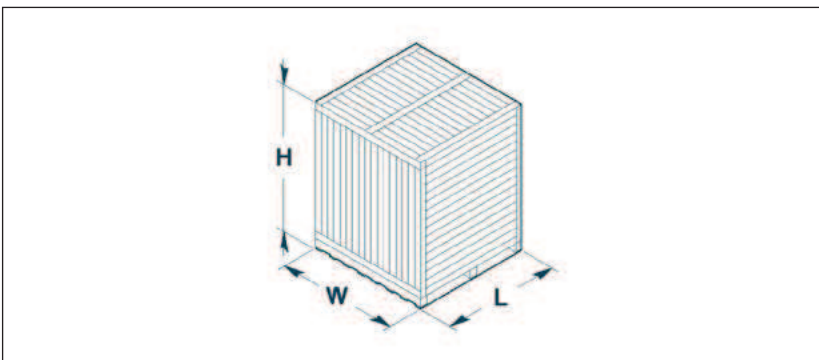

Description		Units of measurement	Value	
LxW)	Max: dimensions	mm	∅ 1650	∅ 1800
			1000 x 1200	1200 x 1200
H1)	Max. height	mm	2200	
		mm	2400	
		mm	2800	
		mm	3100	

TECHNICAL INFORMATION

Machine dimensions

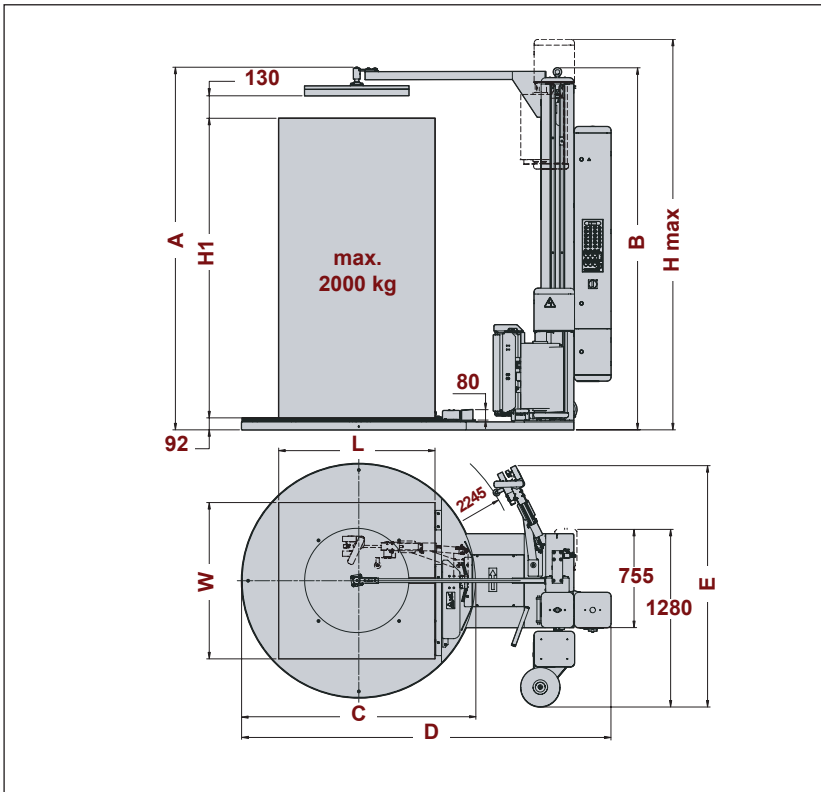

<i>mm</i>	<i>Value</i>			
Mast	H=2200	H=2400	H=2800	H=3100
A	2630	2830	3230	3530
B	2580	2780	3180	3480
max carriage H	2820	3020	3415	3715
H1	2200	2400	2800	3100
Rotating table\			Ø 1650	Ø 1800
C			1650	1800
D			2755	2830
E			1740	1815
L			1000	1200
W			1200	1200

## TECHNICAL INFORMATION

**3.8. NOISE LEVEL**

While working, the machine reaches the noise levels shown in the table.

Acoustic power measured during working according to:

- ISO 3746-79
- ISO/CD 11202-1997

<i>Description</i>	<i>Average level of pressure on the measurement surface (Lpm)</i>	<i>Acoustic power output (Lw)</i>	<i>Lop- Level at the operator's place (Lop)</i>
Functioning in working conditions	62.8 dB (A)	79.8 dBw (A)	69.2 dB (A)

 **Danger Warning**

**Prolonged exposure over 80 dB (A) dB (A) may cause health problems. The use of appropriate protection systems is recommended (headphones, ear plugs, etc.).**

**3.9. INSTALLATION ENVIRONMENT CHARACTERISTICS**

Careful consideration must be given to the place where the machine is to be installed, in order to ensure that it may be easily operated, without creating any unnecessary risks for personnel.

Therefore we suggest the following prerequisites.

- Room temperature of between +5°C and 40°C.
- a suitably aired place so that when the machine is working, the degree of humidity is less than 95%.
- Room lighting must be normal (recommended 250÷650 lux) also in order to create a pleasant and relaxing condition for machine operators.
- A perimeter area around the machine that is also required for safety reasons .
- A flat surface, steady and without vibrations with adequate weight supporting capacity.

The area must be equipped with a power supply socket and a compressed air supply socket.

 **Danger Warning**

**Use of this machine in explosive environments or when exposed to the elements is strictly forbidden.**

 **Danger Warning**

**Check that there are no persons within machine's working range.**

### 4.1. RECOMMENDATIONS FOR HANDLING AND LOADING

** Important**

Handling and loading must be carried out following the instructions provided by the manufacturer that are displayed on the machine's labels and in the instructions for use.

The person authorized to carry out these operations must, if necessary, prepare a "safety plan" to safeguard the safety of people directly involved.

Use normal lifting equipment and means of transport, in accordance with the instructions to be found on the packaging itself.

Those persons responsible for lifting and transportation operations must decide which are the most suitable means according to the machine's destination.

Carefully read the "Instructions for use" specified in the manual and those applied directly to the machine and/or the package.

Provide suitable safety conditions in compliance with the regulations on workplace safety to prevent and minimise the risks.

Pay attention to the **SAFETY WARNINGS**, do not use the machine for **UNSPECIFIED PURPOSES** and assess the possible **RESIDUAL RISKS**.

### 4.2. PACKING

The packing is realised, keeping the overall dimensions low, also in consideration of the transport chosen.

To facilitate transport, shipping can be performed with some components disassembled and appropriately protected and packaged.

Some parts, especially electric equipment, are protected with anti-moisture nylon covers.

The cases are marked with all necessary information for loading and unloading.

Packaging material should be appropriately disposed according to the laws in force.

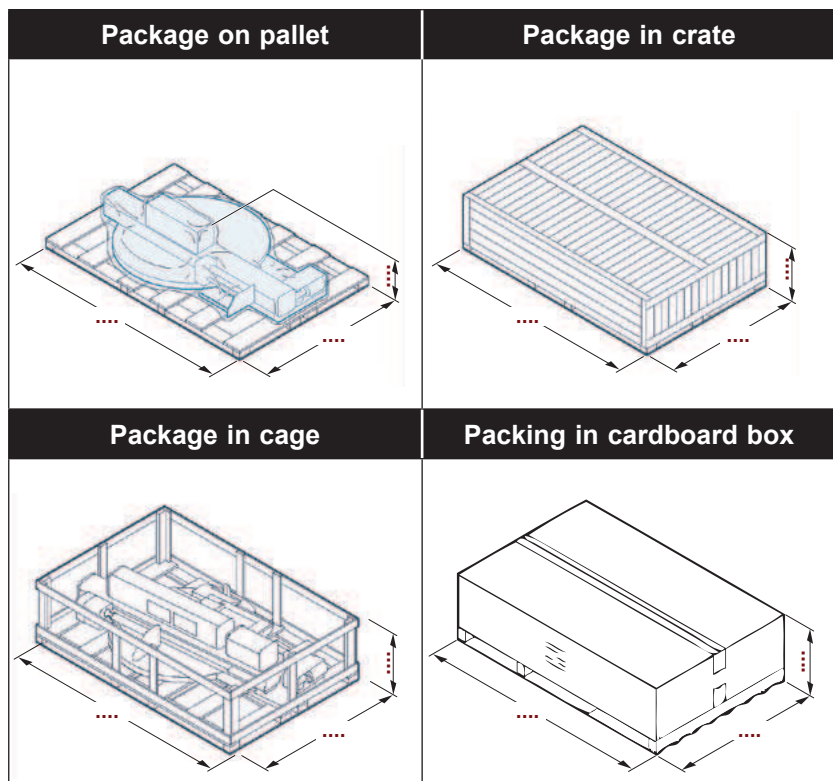

INFORMATION ON HANDLING AND INSTALLATION OPERATIONS

**4.3. TRANSPORT AND HANDLING**

Transport, also according to the destination, can be performed by different vehicles.

The diagram represents the most popular solutions.

During transport, with the purpose to avoid sudden movements, adequately anchor the machinery to the means of transportation

**Important**  
 For further transportation, recreate the initial packaging conditions for transport and handling.

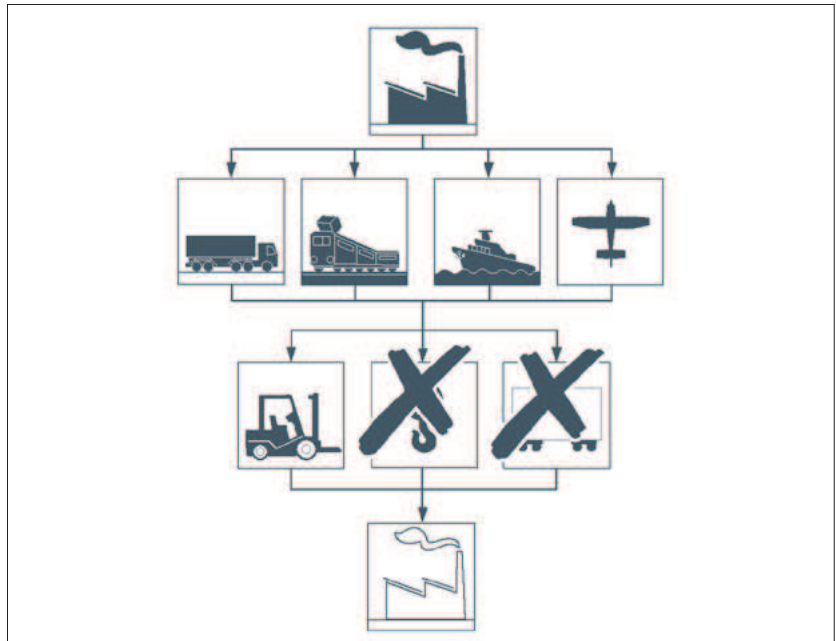

**4.4. HANDLING AND LIFTING**

The machine can be moved with a forklift with suitable load capacity by inserting the forks in the points indicated directly on the machine.

The transport and lifting equipment must be operated by an authorised person qualified to use the equipment in question

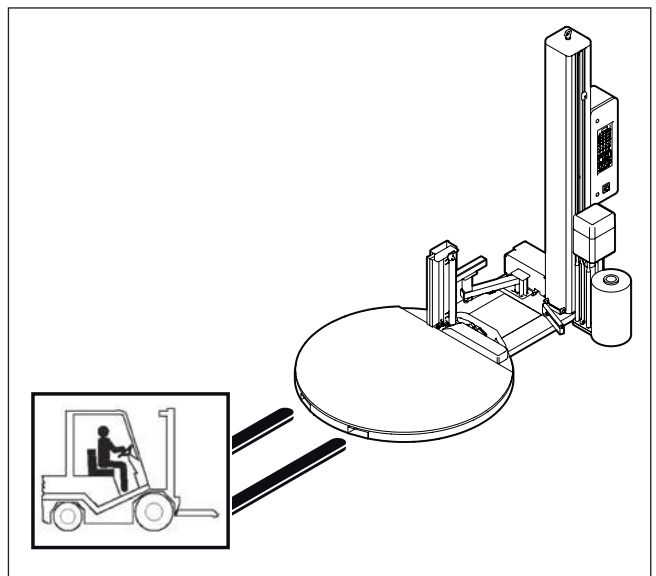
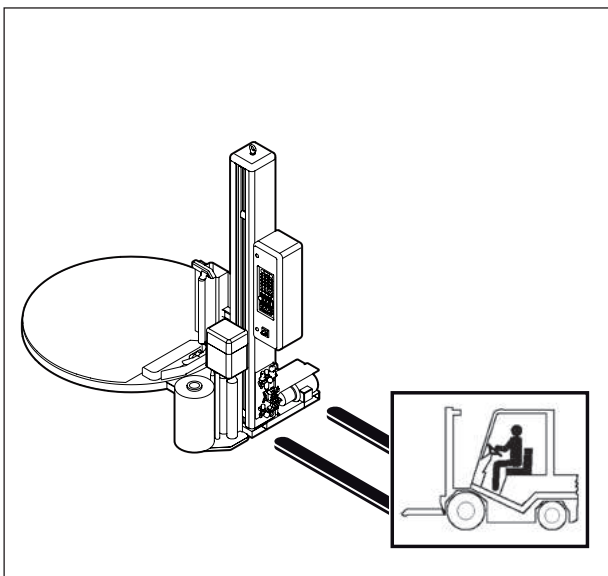

INFORMATION ON HANDLING AND INSTALLATION OPERATIONS

#### 4.5. MACHINE INSTALLATION

Install the machine in a location having the requirements listed in paragraph 3.9. "Installation environment characteristics".

If necessary, determine the exact position by tracing the coordinates and correctly position.

** Danger  
Warning**

**Authorised technical service personnel must perform installation and assembly operations.**

Proceed as indicated.

1. Insert the fork lift's forks in the specially designed spaces provided in the base.
2. Lift the machine from the pallet.

** Danger  
Warning**

**To perform the operation in safety, insert some wooden spacers below the forks of the lift truck and position all to the floor**

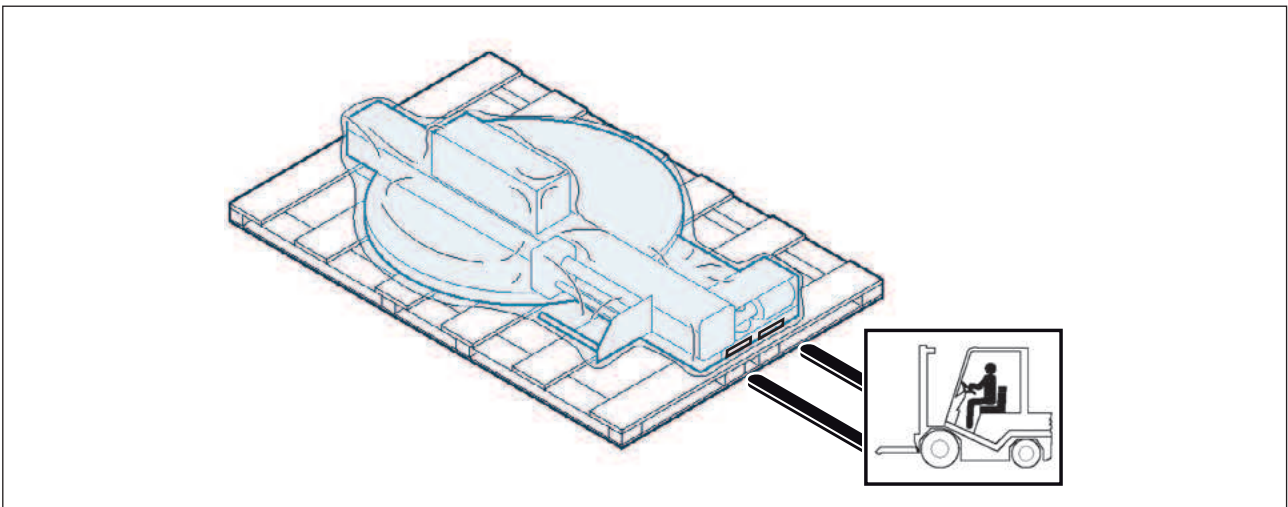

3. Place the machine in the area assigned for assembly.

** Important**

**It must be placed on a smooth, level surface for assembly.**

INFORMATION ON HANDLING AND INSTALLATION OPERATIONS

**Electrical box assembly**

Proceed as indicated.

1. Cut the band (A) that holds the electrical wires together.
2. Disassemble the fastening brackets (B).
3. Insert the electrical wires (C) inside the sliding shaft.
4. Lift the electrical box (D).
5. Fasten the electrical box to the slide mast using the screws (E).
6. Close cover (F) of the electrical box (D) using wrench (G).

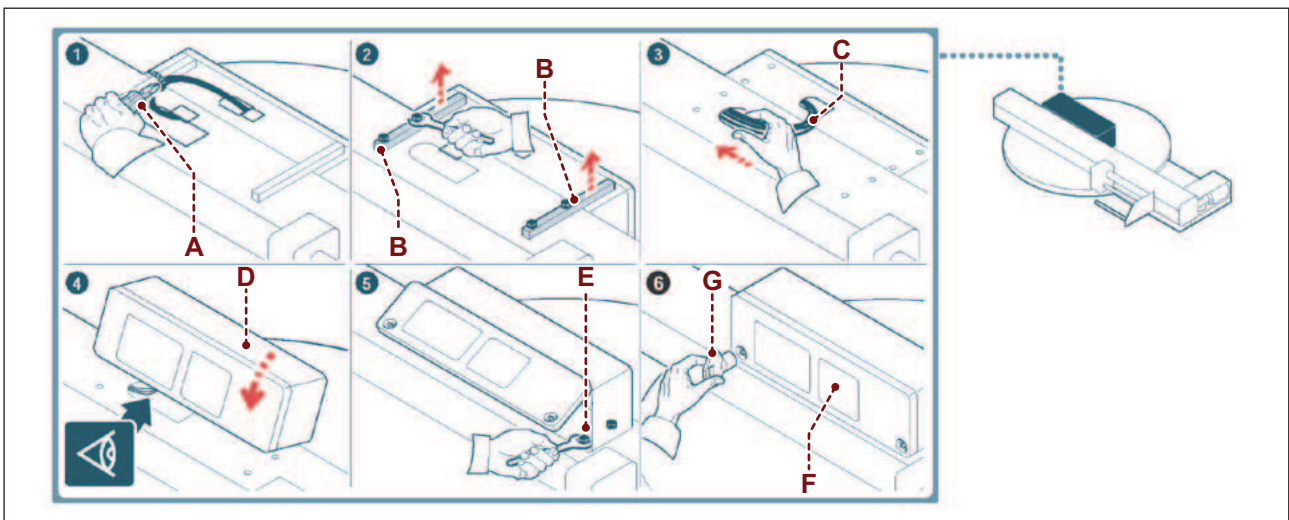

**Slide guide mast assembly**

Proceed as indicated.

1. Lift and position the slide guide mast (H) over the rotating table in correspondence with the hinge.
2. Insert the screws (L) in the hinge without tightening them.

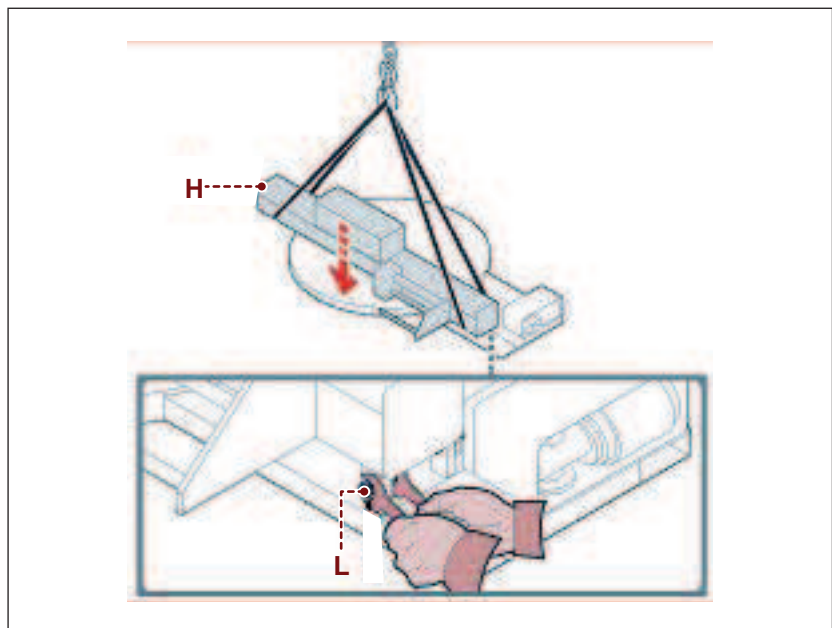

INFORMATION ON HANDLING AND INSTALLATION OPERATIONS

3. Secure the hook of the lifting equipment to the bracket (M) of the sliding mast and tension it.
4. Lift the sliding mast (H).

**Note: Certain configurations may require that you first position the shaft in its seat before you lift it.**

5. Secure the sliding mast to the machine body with the screws (N).
6. Tighten the hinge screws (L).

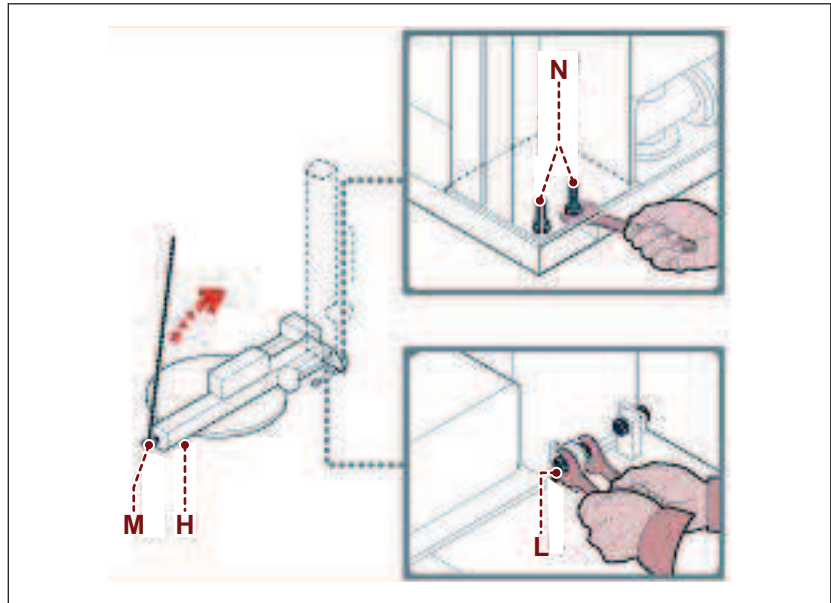

**Assembly of the cutting unit/ sealing units**

Proceed as indicated

1. Lean the pad unit (A) on arm (B)
2. Insert the spar (D) to fix the sealing unit tightening the screws (C)
3. Place the arm as to oppose the arrows located on the arm (B) and on pad (A).
4. Perform pneumatic connections (E) being careful to connect fittings and tubes marked with the same number.
5. Perform electrical connections (F) between the mobile arm and the machine structure.
6. Connect the sensors (G) on the cylinder arm (A) marked with the same number.

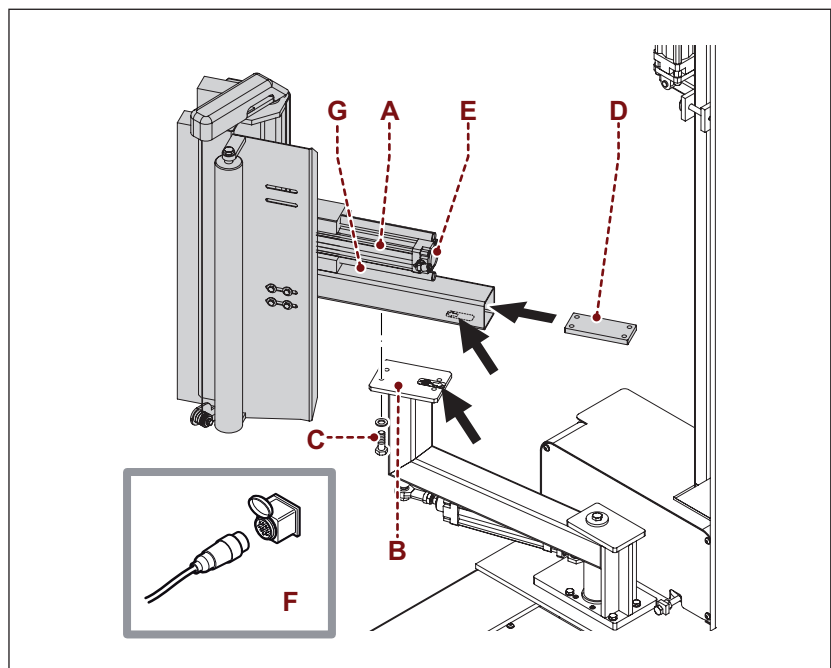

INFORMATION ON HANDLING AND INSTALLATION OPERATIONS

**Pneumatic presser assembly (optional)**

Proceed as indicated

1. Fasten the guide (P) to the slide guide mast with the screws (Q).

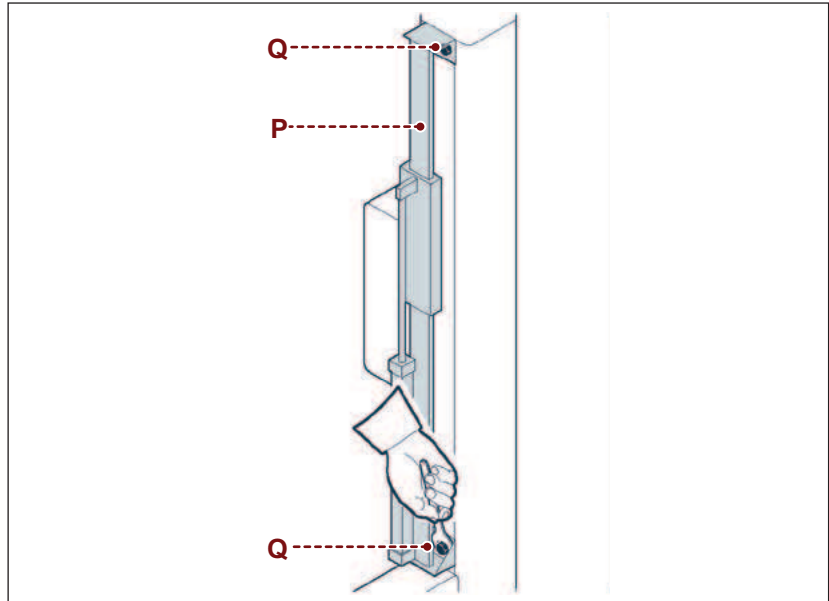

2. Assemble the arm (R) to the guide and fasten with the screws (S).

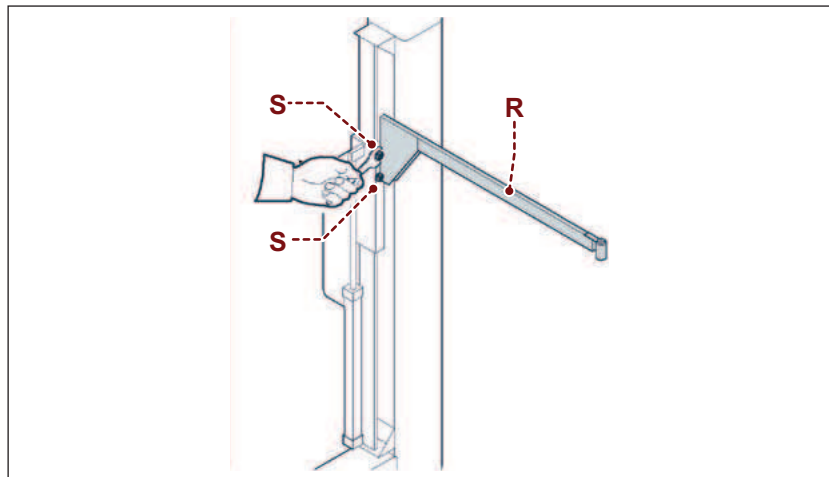

3. Assemble the presser plate (T) to the arm.
4. Connect the pneumatic tubes according to the attached diagrams.

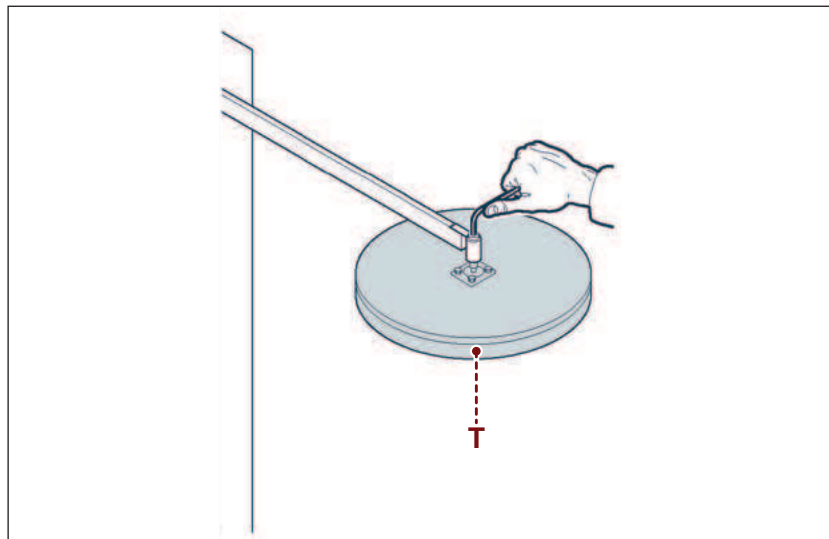

**Important**

If the pressure platen is delivered with the machine, the pneumatic connections have already been performed by the manufacturer.

## INFORMATION ON HANDLING AND INSTALLATION OPERATIONS

**4.6. FASTENING THE MACHINE**

When you have finished assembling the units and checking the levels, squaring, parallelism, and orthogonal shape, you must fasten the machine body onto the floor.

Depending on the characteristics of the flooring, it may be necessary, before positioning the machine, to create foundations at the points of the various support legs.

** Important**

**The creation of the foundations and the fastening of the machine are fundamental operations for ensuring the stability and correct functioning of the machine.**

If necessary, insert metal plates (A) between the screws and the floor.

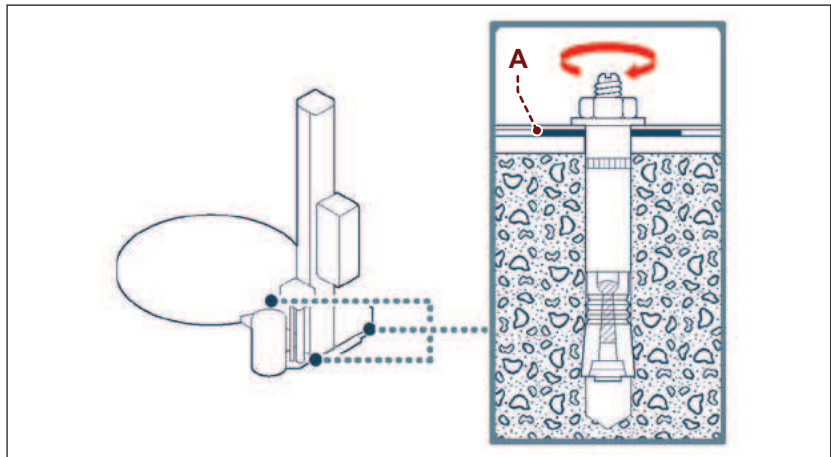
**4.7. SETTING THE MACHINE INTO THE GROUND**

Dig out a ditch in the floor in which to place the template (C) and cast cement to fasten it into place.

Template (C) is supplied on request (OPTIONAL).

** Important**

**The depth (X) must be equal to the height of the machine's base plate.**

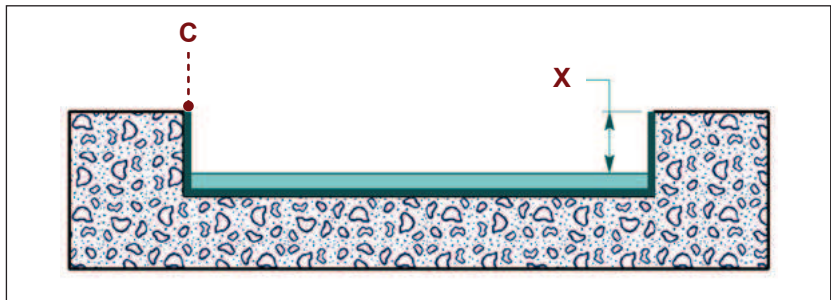

#### 4.8. RECOMMENDATIONS FOR CONNECTIONS

##### **Important**

The connections must be made in accordance with the specifications supplied by the manufacturer in the enclosed diagrams.

The person authorized to carry out said operation must possess the skills and experience acquired and acknowledged in the specific sector, must perform the connection workmanlike and keep into account all the statutory and legislation requirements.

Once the connection has been completed, before commissioning the machinery, it is necessary to perform an overall control to verify if said requirements have been complied with.

#### 4.9. PNEUMATIC CONNECTIONS

Proceed as indicated.

1. Insert a flexible tube on the end of the rubber fitting and fasten it with a metallic screw clamp (A).
2. Check that the valve (B) is in the "OPEN" position.
3. Turn on the power supply line.
4. Check that the manometer reads a pressure of at least 6 bar and turn knob (C) to compensate any pressure differences.  
Repeat this operation with the machine running.

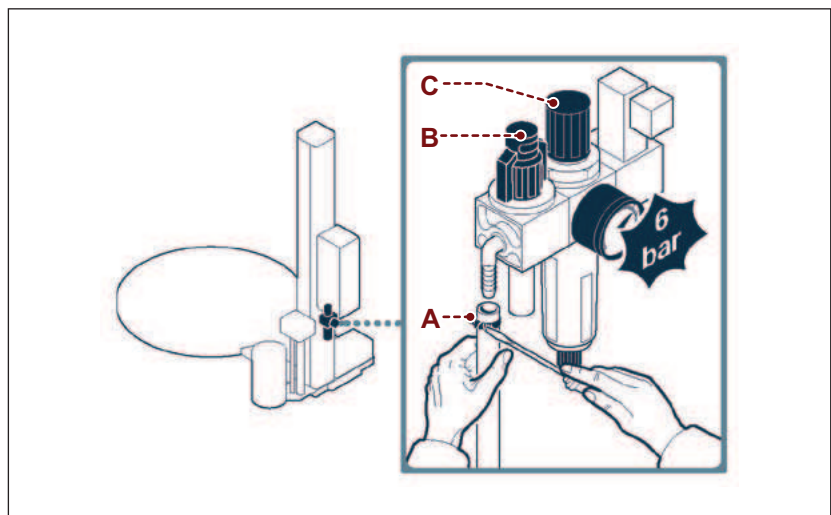

## INFORMATION ON HANDLING AND INSTALLATION OPERATIONS

**4.10. ELECTRICAL CONNECTION**

Proceed as follows for electrical connections.

1. Check that the line voltage (V) and the frequency (Hz) match those of the machine (see identification plate and wiring diagram).
2. Bring the main switch into position **0 (OFF)**.
3. Connect the power cord as illustrated, according to the network mains.

** Important**

The earth wire (yellow and green) must be connected to its earth terminal PE.

Refer to the wiring diagram given in the machine powering page to check the correct dimensions of the power cable and protection device.

1. Use the main switch to start the machine.
2. Press the “Reset” button .
3. When the “Start” button is pressed, the arm must rotate counter clockwise.

** Important**

Do not for any reason invert the phase connections of the electric motors.

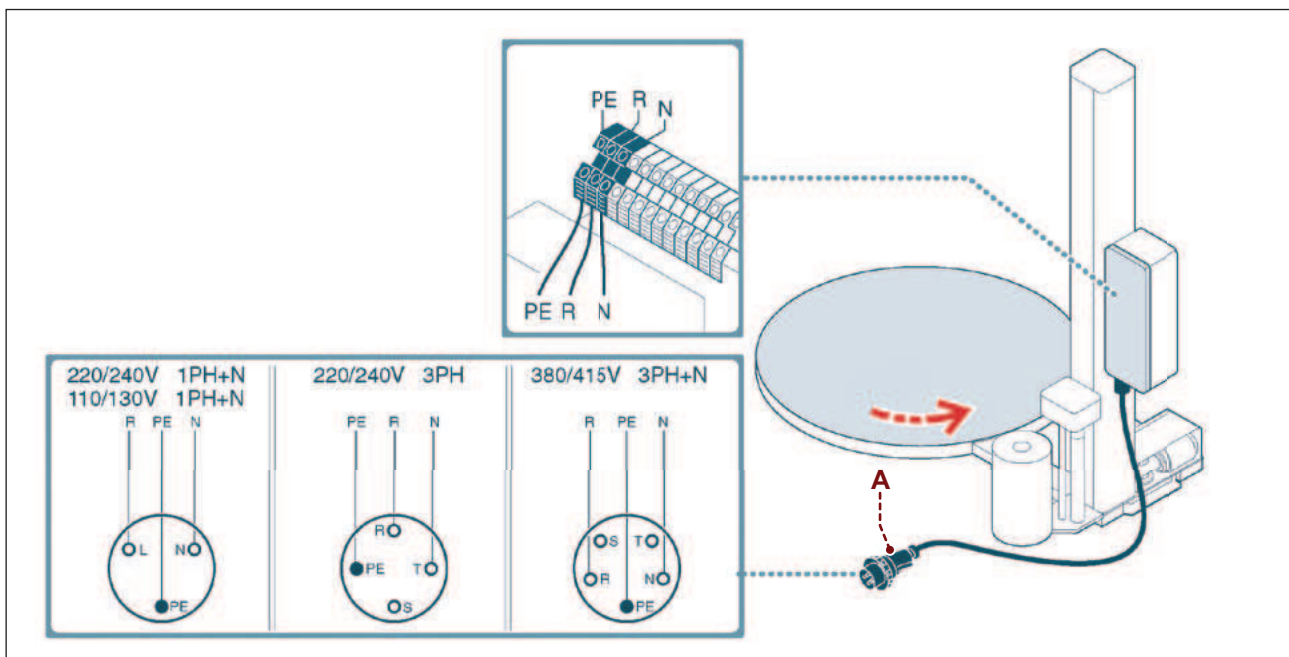

## INFORMATION ON ADJUSTMENTS

### 5.1. RECOMMENDATIONS FOR ADJUSTMENTS

- Before performing any operation, the authorised operator must make sure that he/she understood the "Instructions for use".
- Pay attention to the SAFETY WARNINGS, do not use the machine for UNSPECIFIED PURPOSES and assess the possible RESIDUAL RISKS.

#### **Important**

**Before carrying out any adjustment operations, activate all the safety devices provided for, and evaluate if it is necessary to adequately inform the operating personnel or the personnel nearby. It is important to adequately mark nearby areas and prevent the access to all devices that, if activated, could result in sudden dangerous conditions and risks to the safety and health of personnel.**

### 5.2. ADJUSTING FILM "STRETCH"

1. Use the illustrated button on the control panel to perform this adjustment (see "Description of (yellow) buttons for parameter setting").



### 5.3. ADJUSTING CHAIN TENSION

Proceed as indicated.

1. Remove the cover guard (A).
2. Loosen the fastening screws (B) of the gear-box.
3. Tighten the reducer fastening screws (B) when finished.

#### **Important**

**To check chain tension, use the method shown in the figure.**

**The movement (R) that ensues must be 5÷7,5 mm.**

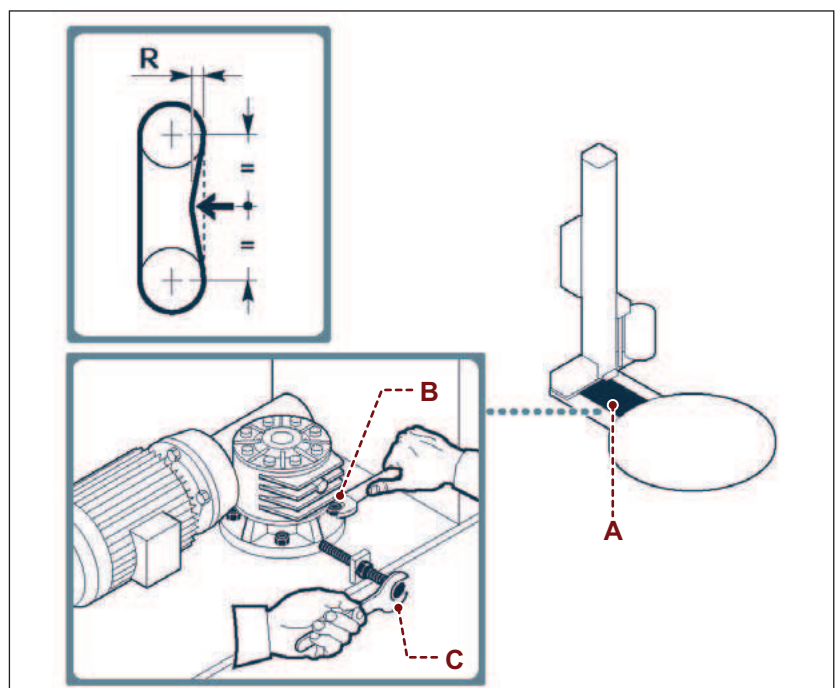

## INFORMATION ON ADJUSTMENTS

**5.4. REEL CARRIAGE LIFTING CHAIN ADJUSTMENT**

Proceed as indicated.

1. Lift the carriage. (see “Emergency stop and restart”).
2. Use the register nuts (**B**) to adjust the chain.

**Note: Tighten all the nuts the same to achieve the right adjustment.**

** Important**

To check chain tension, use the method shown in the figure.

The movement (**R**) that ensues must be  $10 \div 15$  mm.

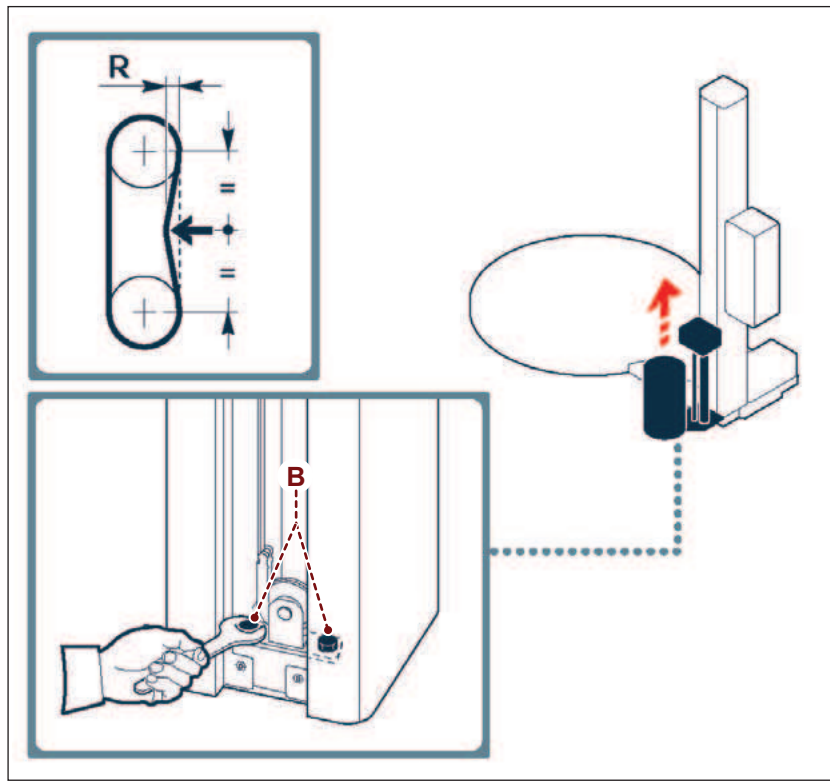
**5.5. PRESSURE PLATEN HEIGHT ADJUSTMENT**

This adjustment must be done in a different way according to the type of device installed.

- Rod pneumatic cylinder.
- No rod pneumatic cylinder.

**Rod pneumatic cylinder**

Proceed as indicated.

1. Loosen the screw (**G**).
2. Adjust the height of the pneumatic cylinder (**E**) on the guide (**F**) according to the size of the product to be wrapped.
3. Tighten the screw (**G**).

**Note: For loads with a height lower than 1400 mm you will have to turn the clamp arm upside-down (see “INSTALLATION OF DISMOUNTED PARTS”).**

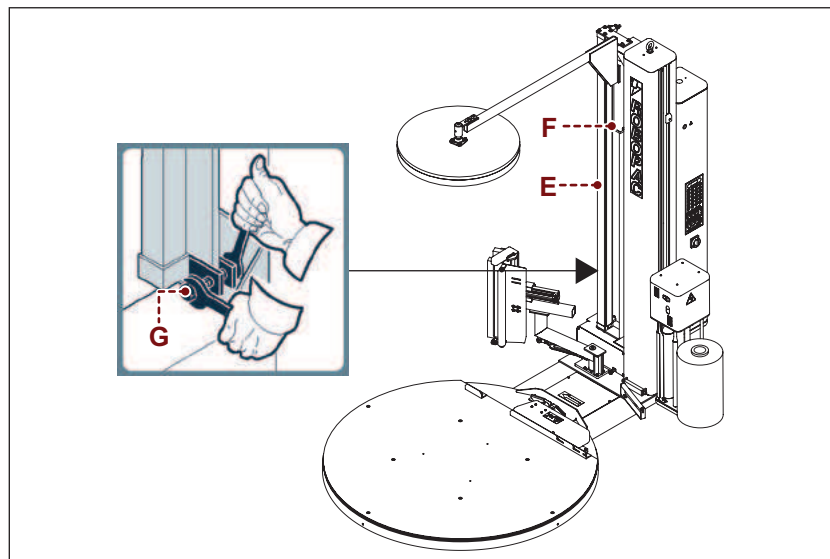

INFORMATION ON ADJUSTMENTS

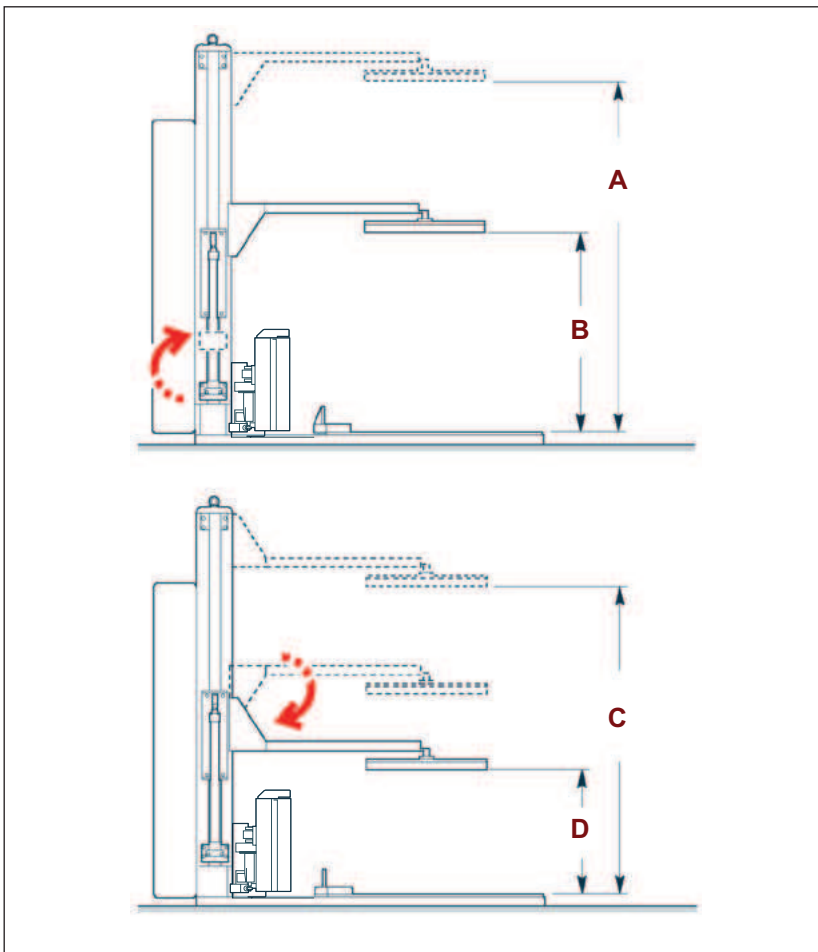

<i>Pneumatic pressure platen</i>				
	<i>H 2350</i>	<i>H 2550</i>	<i>H 2950</i>	<i>H 3250</i>
<b>A</b>	2350 mm	2550 mm	2950 mm	3250 mm
<b>B</b>	1385 mm			
<b>C</b>	1585 mm	1785 mm	2185 mm	2485 mm
<b>D</b>	785 mm			

INFORMATION ON ADJUSTMENTS

**No rod pneumatic cylinder**

This cylinder does not require adjustments for wrapping heights above 860 mm. For lower heights you will have to turn the clamp arm upside-down (see 4.5. “Machine Installation”).

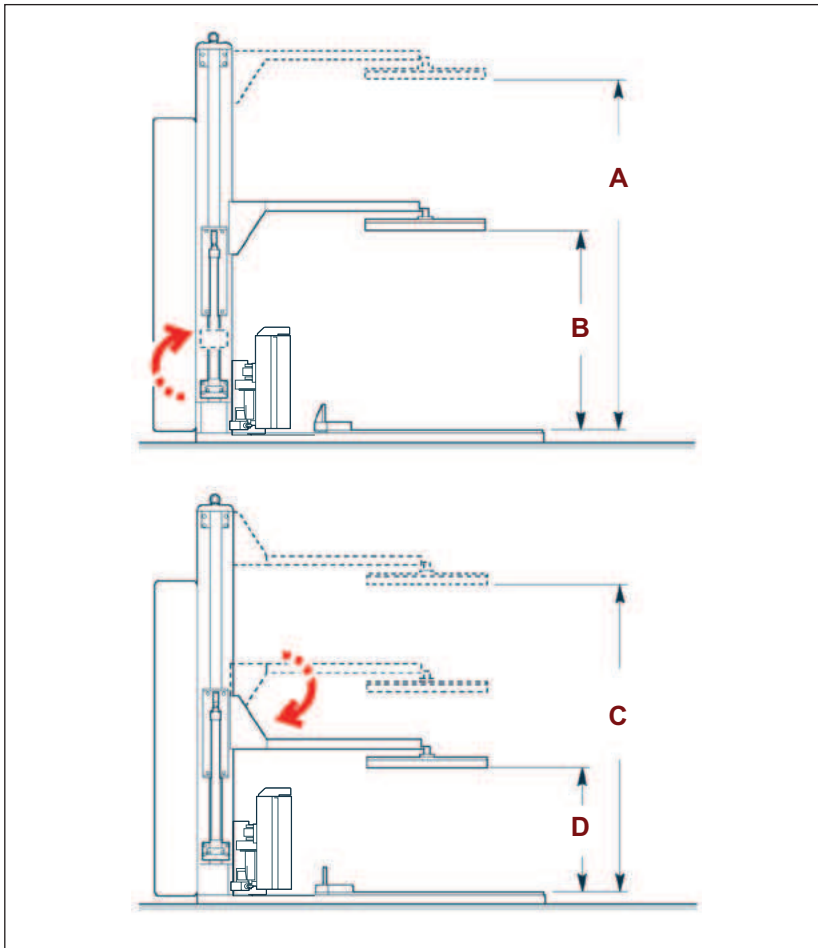

	<i>Pneumatic pressure platen</i>			
	<i>H 2350</i>	<i>H 2550</i>	<i>H 2950</i>	<i>H 3250</i>
<b>A</b>	2350 mm	2550 mm	2950 mm	3250 mm
<b>B</b>	835 mm			
<b>C</b>	1385 mm	1585 mm	1985 mm	2285 mm
<b>D</b>	235 mm			

INFORMATION ON ADJUSTMENTS

**5.6. CLAMP CLOSING ADJUSTMENT**

Adjust the flux regulator opening on the clamp command solenoid valve (see 10.1. "Pneumatic circuit diagram") so that its closing time is between 1-2 seconds.

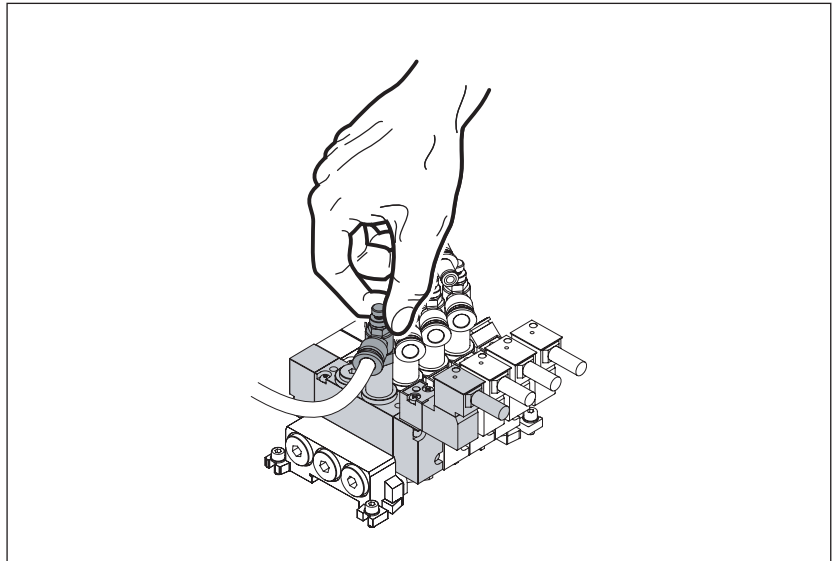

# ABOUT THE USE

### 6.1. RECOMMENDATIONS FOR OPERATION AND USE

- Before performing any operation, the operator must make sure that he/she understood the “Instructions for use”.
- When using the machine for the first time, the operator must read the manual and identify the controls and simulate some operations, especially the start-up and shutdown.
- Check that all safety devices are installed correctly and in good working order.
- Only implement the uses intended by the manufacturer and do not tamper with any device to obtain performances different from the intended ones.



#### **Important**

**Accident frequency derived from machine use depends upon many factors that cannot always be foreseen and controlled.**

**Some accidents are the consequence of environmental factors that cannot be foreseen, others are especially the consequence of the users' behaviour.**

**At the first start up - being authorized and duly informed - they must simulate, if necessary, some manoeuvres to identify the main controls and functions.**

**Only implement the uses intended by the manufacturer and do not tamper with any device to obtain performances different from the intended ones.**

**Before using the machinery check that all safety devices are in good working order and correctly installed.**

**The users, as well as committing to comply with these requirements, must apply all the safety rules and carefully study the description of the controls and the commissioning of the machinery.**

ABOUT THE USE

**6.2. CONTROL DESCRIPTION**

The figure shows the major control units.

Refer to the paragraphs for further details, as indicated.

**Note: Some keys may be disabled according to machine version and installed options.**

- A) Electromechanical controls.
- B) Synoptic panel.
- C) (Grey) Programme setting keys.
- D) (Yellow) Buttons for parameter setting.
- E) (Green) Buttons for cycle selection.
- F) Digital display: To visualise work parameters and alarm signals.
- G) (Green) buttons for manual comand.
- H) Stretch control button.

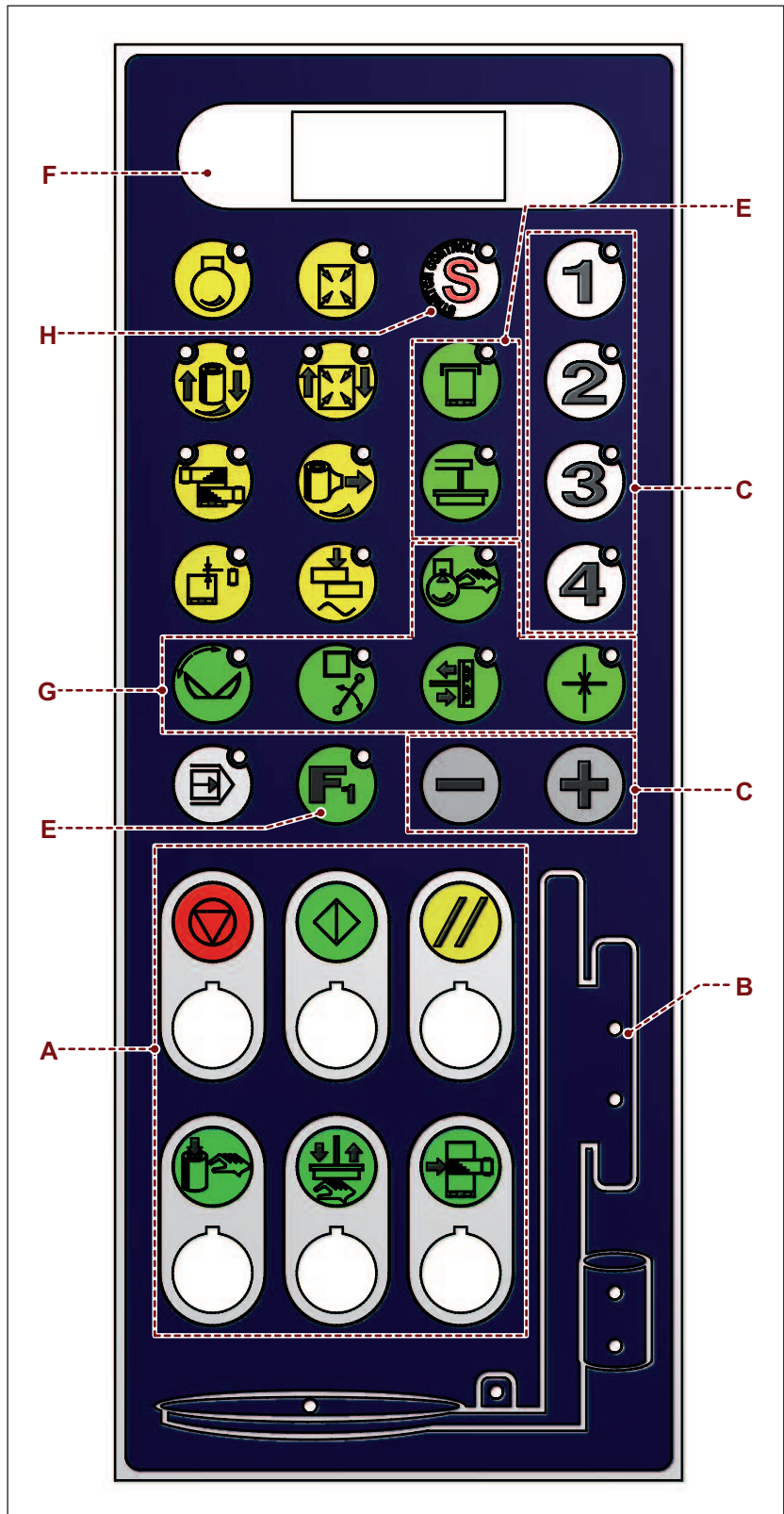

## ABOUT THE USE

**Electromechanical control description**

- 1) **Cycle start button**  
To start the automatic wrapping cycle
- 2) **Cycle stop button**  
To stop automatic wrapping cycle
- 3) **Reset button**  
Either to reset the machine before re-starting it after an emergency stop, or to re-start the machine after a stop caused by a power supply interruption
- 4) **“Carriage descent” manual button**  
Press for spool carriage descent and press again to stop
- 5) **“Pressure platen up/down” manual button**  
Press to change pressure platen’s position (top or bottom)
- 6) **“Carriage stop” button**  
Stops the reel carriage during the wrapping phases as to perform a greater number of wraps in the same position of the pallet.

One of the indicated modes can be chosen:

- Press and keep pressed the button for a time greater than 2 seconds.  
Until the button is kept pressed, the carriage continues wrapping the pallet in the same point.  
Upon release of the button, the carriage restarts the normal wrapping cycle.
- Press the button by impulses for a time lower than 2 seconds (max. 5 impulses).  
The turntable performs a number of rounds equal to those of the preset impulses and the carriage continues wrapping the pallet in the same point.  
Upon completion of the preset impulses, the carriage restarts its normal wrapping cycle.

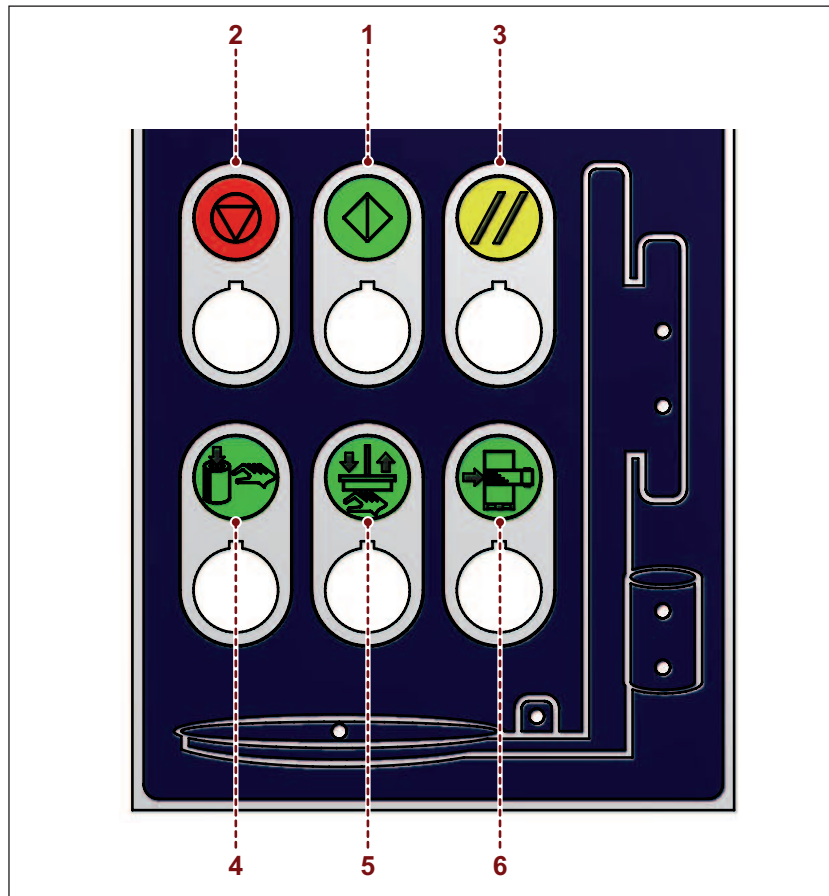

## ABOUT THE USE

**Description of synoptic panel**

The lighted LEDs indicate machine's critical areas.

The display indicates the code of proper alarm (see 8.2. "Alarm messages").

- 1) **"Reel carriage lifting motor" alarm:** indicates motor malfunction.
- 2) **"Pre-stretch motor" alarm:** indicates motor malfunction.
- 3) **"Turntable blocked" alarm:** indicates that table rotation is blocked by an obstacle or by malfunction.
- 4) **"Main frequency changer alarm":** indicates overheating of frequency changer.

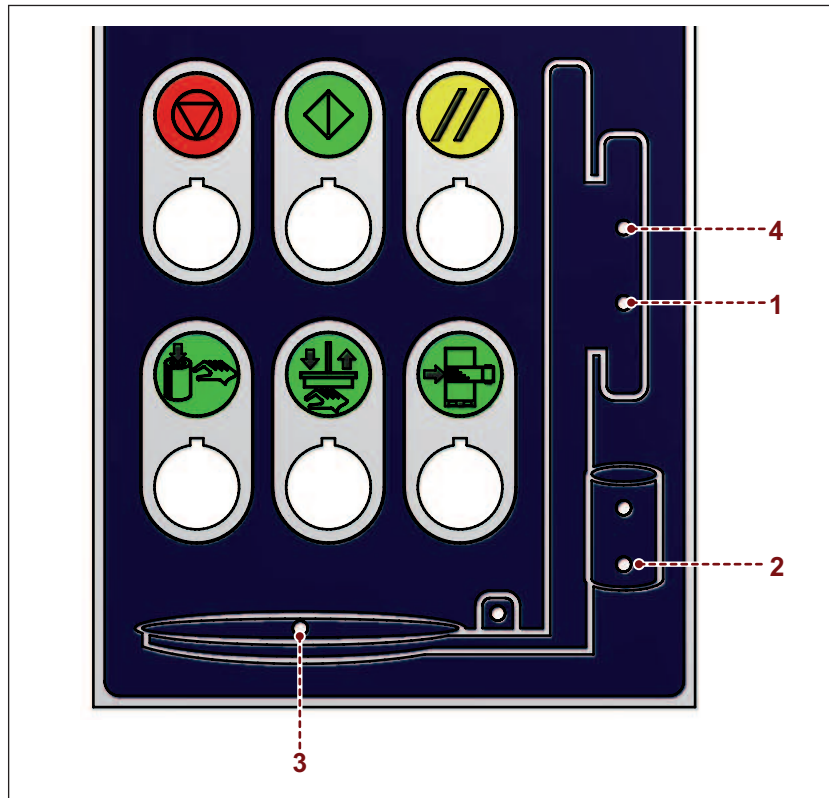

## ABOUT THE USE

## Description of (grey) buttons for programme setting

- 1) **Increase values key:**  
Increases the value of the selected parameter.  
The value is increased by a single unit each time the button is pressed.
- 2) **Decrease values key:**  
To decrease the value of the selected parameter.  
The value decreases by one unit each time the key is pressed.
- 3) **Cycle programming button: to save a wrapping cycle:**  
To save a wrapping cycle.

**Note: The parameters set overwrite the previous ones and are automatically memorized.**

- 4) **“Production data” button**  
To display the following data.
  - D1 cycle partial counter.
  - D2 total cycle counter 1.000÷999.000.
  - D3 total cycle counter 0÷999.

**Note: to reset, contemporaneously press buttons (1-2) when indication “D1” appears.**

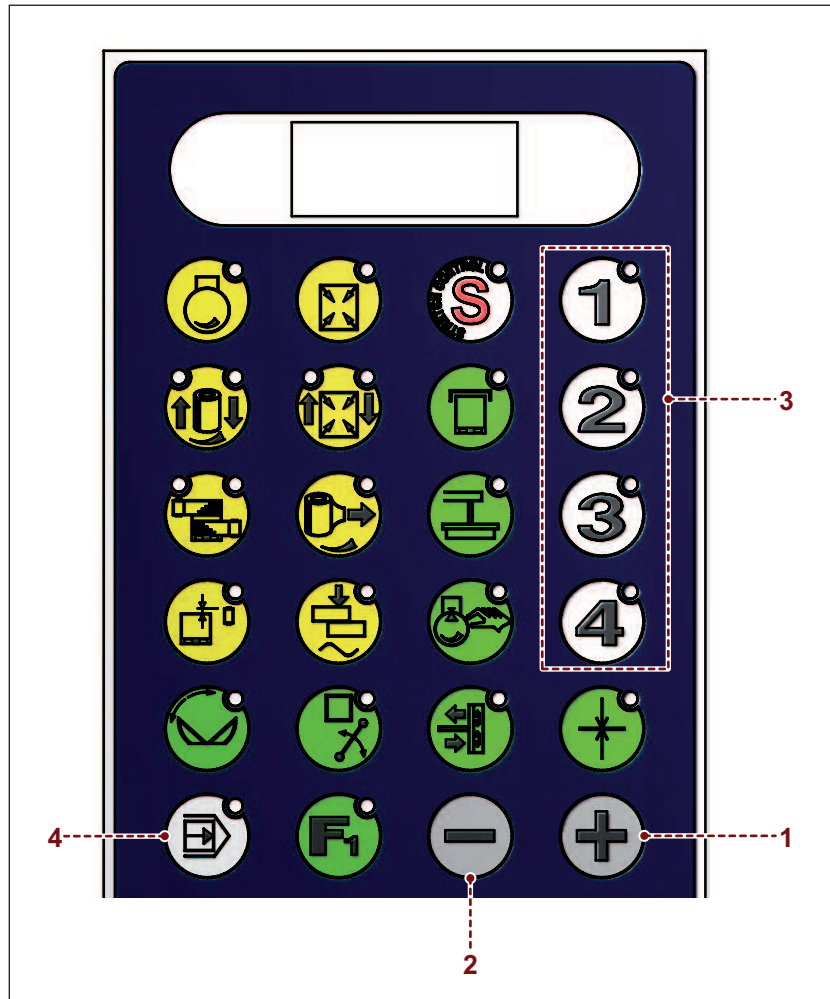



ABOUT THE USE

**Description of (green) buttons for cycle selection**

- 1) **“Stretch control” button:**  
Enables variable pre-stretch on carriage PDS.
- 2) **Top sheet cycle key:**  
Selects the cycle that allows the operator to cover the pallet with a layer of film.
- 3) **Pressure platen cycle button:**  
Selects the wrapping cycle with the intervention of the clamp.
- 4) **Button “F1”:**
  - Press the button and make sure the relative LED switches on.  
The cycle “america” has been programmed in which the carriage rises and performs the bottom wrapping only at the end of the cycle.
  - Press the button for **5 seconds** to make the LEDs flash.  
All automatic mechanisms are disabled and the machine operates as a standard turntable .

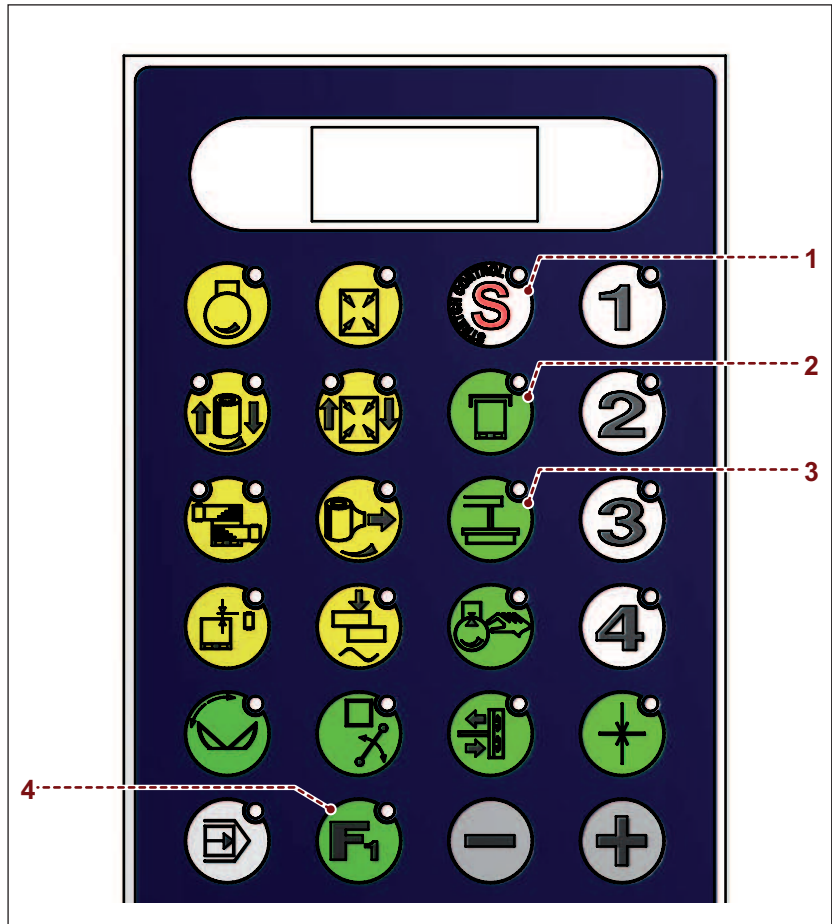

ABOUT THE USE

**Description of the (green) manual control buttons**

- 1) **“Turntable rotation” button:**  
Enables the turntable’s rotating phase (LED on).
- 2) **“Arm rotation” button:**  
Enables arm rotation.  
has two functions.
  - If the arm is rotated backwards, press key to rotate it forward.
  - If the arm is rotated forward, press key to rotate it backward.
- 3) **”OPEN/Close clamp” button:**  
has two functions.
  - If the clamp is open, press key to close it.
  - If the clamp is closed, press key to open it.
- 4) **“Pad position” button (CW version only):**  
has two functions.
  - If the pad is in the forwarded position, press key to set it backward.
  - If the pad if in the backed position, press key to set it forward.
- 5) **“Air release” button:**  
to release air in the pneumatic circuit.

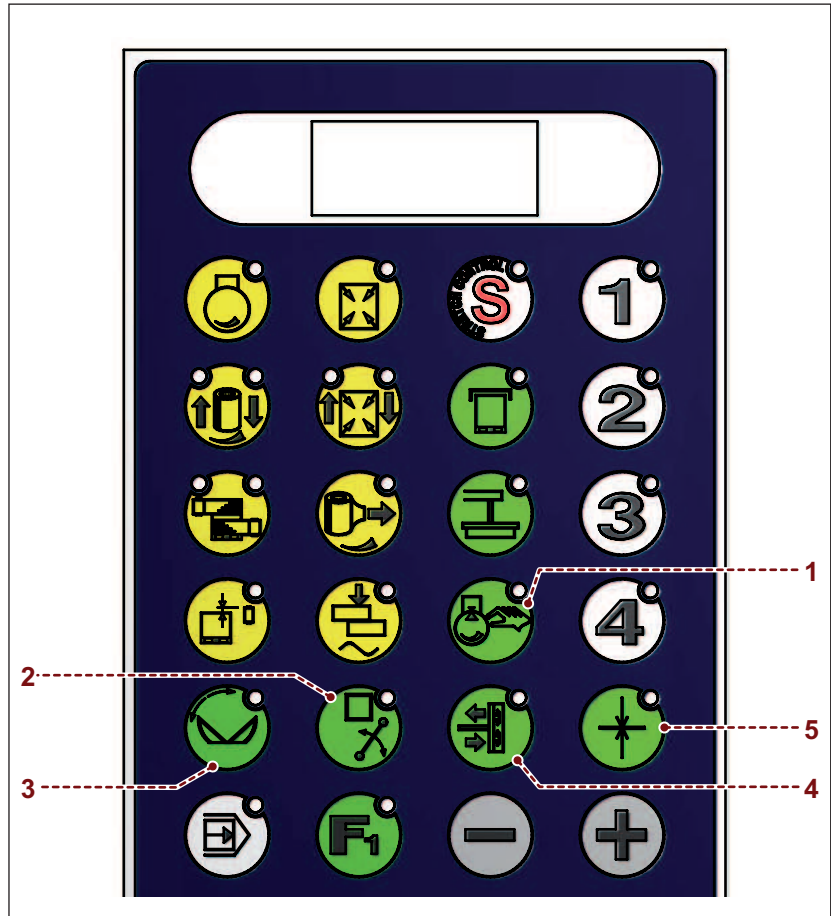



ABOUT THE USE

**6.4. WRAPPING CYCLE RESET**

If the machine is stopped while a product is being wrapped, you can resume wrapping by pressing button (A) from where the cycle had stopped last and the cycle will resume without the need for any added operation.

Otherwise, proceed as indicated.

1. Touch the “reset” button (B) to reset the wrapping cycle.
2. Remove product from the machine.

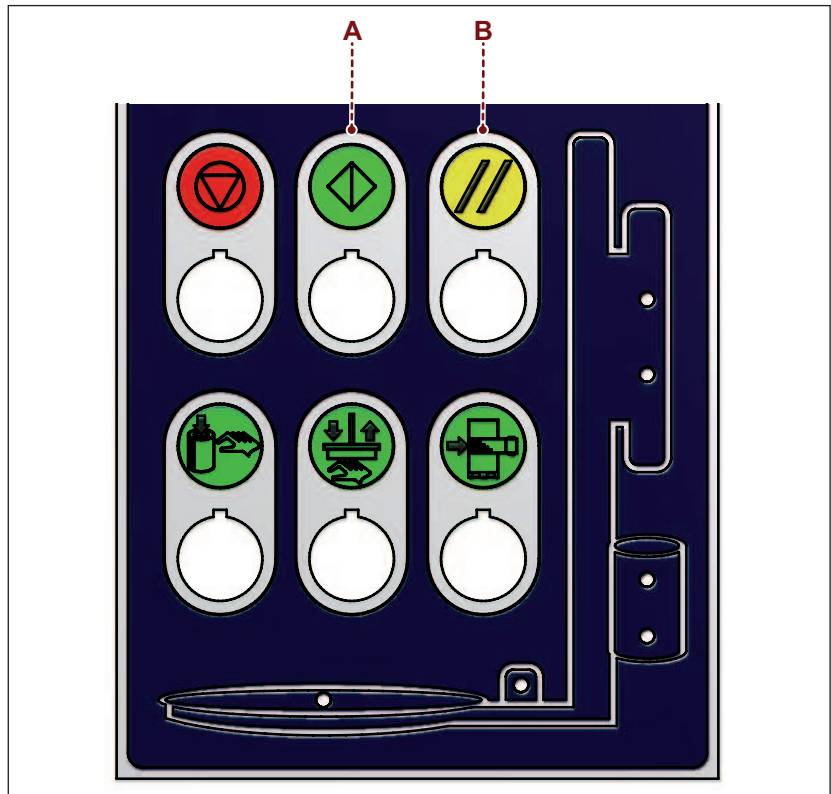

## ABOUT THE USE

**6.5. MACHINE CONDITIONS****Machine isolated from the power supplies**

This machine condition is requested to perform any intervention in dangerous areas or in their immediate surroundings.

It is obtained in the following way:

- Main switch in pos. **0**.
- Air input tap CLOSED.

**Machine on**

This machine condition is necessary to perform all those interventions that need electric and pneumatic power supply on machine.

It is obtained in the following way.

- Air input tap OPEN.
- Main switch in pos. **I**.
- “Reset” button (**B**) has been pressed.

**Machine ready for the cycle**

This machine condition is necessary to start operation.

It is obtained in the following way.

- Machine on.
- Cycle parameters set (see **6.3**. “Cycle parameter setting”).
- Perform the cycle start operations (see **6.9**. “Cycle start”).
- The film must be stuck in the film carriage.

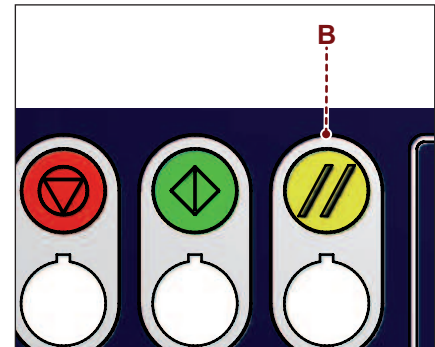
**6.6. MACHINE OPERATION PREPARATION**

Perform the adjustments for operations.

- Wrapping tension (see “Control description”).
- Number of overlaps for each operating cycle (see “Control description”).
- Turntable speed (see “Control description”).

**6.7. MACHINE STARTING**

- All safety devices must be integral and efficient.
- The machine must be cleaned and in order.
- Compressed air supply must be open and pressure adjusted to 6 bar.
- The film reel must be sufficiently full to guarantee operations (see “Reel loading”).
- The reel must be inserted in the proper housing on the reel carriage (see “Reel loading”).
- The film must be unwrapped and properly inserted in the rollers (see “Reel loading”).
- Turn main switch in pos. **I**.

The machine is ready to perform the operation.

**Note: At first start up after a change of operation, it is necessary to perform some trial cycles to check the quality of the wrapping operation.**

ABOUT THE USE

**Reel loading**

Proceed as indicated.

1. Insert film reel (A) in the proper housing (B) on the reel carriage.
2. Disentangle the film and insert it in the rollers as shown in the diagram printed on the carriage.



**Important**

The dents on the carriage indicate the hot-melt gluing side of the film spool (inner or outer) with a dotted line.

3. Collect some film (C) until a thin cord is obtained and make it pass in the conical area (D) of the rollers.
4. Pull the cord outwards. The film will automatically drop on the roller and cover it all along its height.
5. Fit the end of the film tight in the eyelet (E) of the limit stop bracket on the turntable.

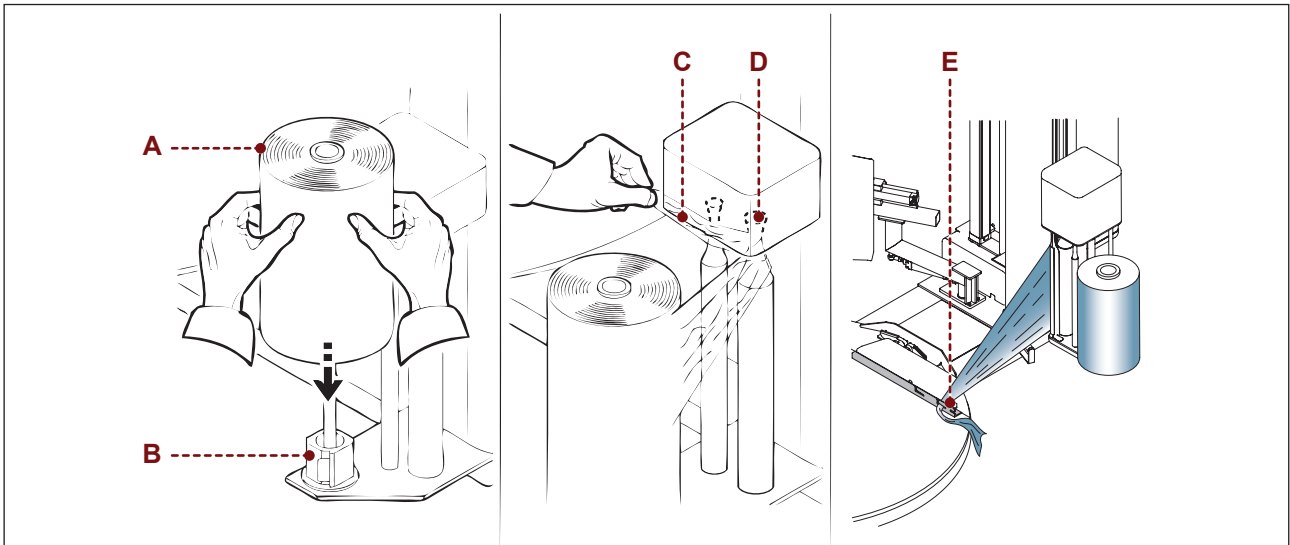

ABOUT THE USE

**6.8. CYCLE START**

For this operation proceed in the following way.

1. Place the load on turntable and set aside the loading device.
2. Fix the film to the stopping bracket.
3. Press the “Cycle start” push-button (A).

The machine performs a cycle and stops automatically.

4. Remove the load and place another one on the table to start a new cycle.

** Important**

To pause the cycle, press the “Stop cycle” (B) button.

Press the “start cycle” button (A) to restart.

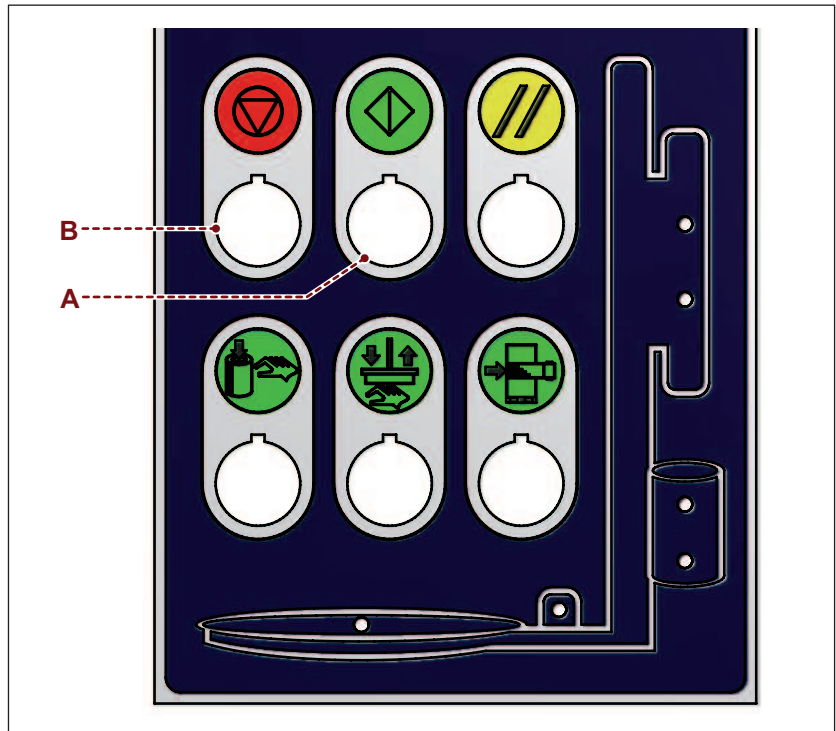

**Use of remote control**

Starts and stops the wrapping cycle with a remote control.

1. Press “Start” to start the cycle.
2. Press “Stop” to stop the cycle.

** Important**

The operator that starts the machine with the remote control, must make sure that operating area is free from obstacles for a correct wrapping cycle.

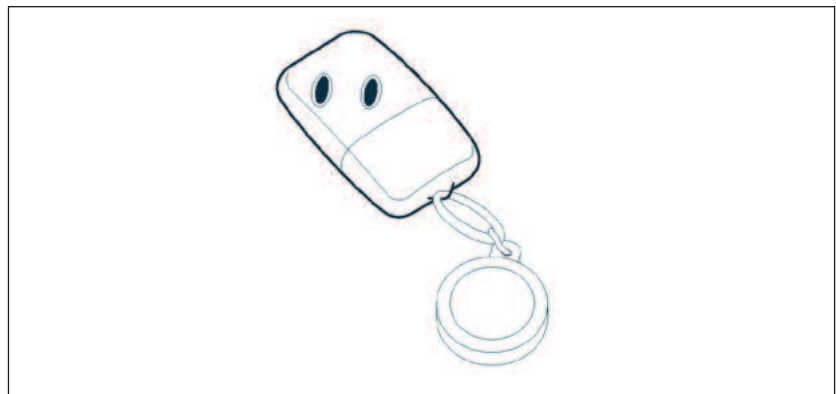

**Use of the “start” chain (Optional)**

Starts the wrapping cycle by chain command.

1. Pull the chain to start cycle.

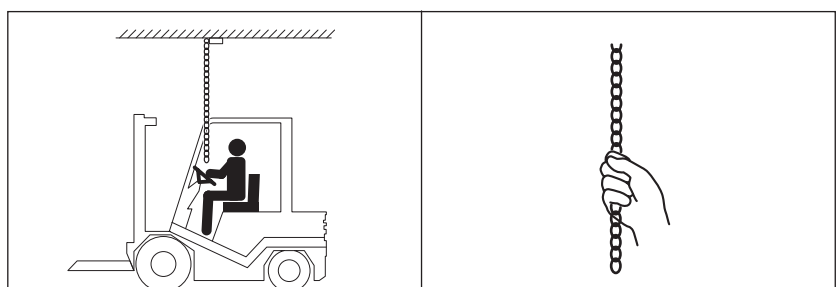

ABOUT THE USE

### 6.9. TYPES OF STOPPING AND STARTING

During operation there can be voluntary or unforeseen conditions that stop the machine.

These are the possibilities.

- temporary stop (voluntary).
- machine stop due to electrical power cut.
- production end stop.
- Emergency stop.

#### Temporary stop (voluntary)

It can occur for a brief work pause, a few minutes.

This operation only requires you to push the “stop cycle” button.



#### **Danger Warning**

**The machine is still running: it is enough to press the “start cycle” button to restart the machine.**

#### Machine stop due to electrical power cut

In case of voluntary interruption of electric power supply, machine stops immediately.

The electrical engines stop.

When electric power supply returns, the machine does not continue its operating cycle but remains still in the same position.

To restart operation:

1. Press “start cycle”, press the reset button, and manually bring the turntable back into phase.
2. If necessary, remove the product to be wrapped or partially wrapped by the machine.

The machine is ready to start a new operating cycle.

#### Production end stop

This situation verifies when the work shift or machine use is over or when the machine remains inactive or not attended to for a certain lapse of time.

1. Turn main switch in pos. **0**.

#### Emergency stop and restart

1. Turn main switch on **O (OFF)** in conditions of imminent risk.

Machine operation stops immediately.

2. After having normalized the working conditions, rotate main switch on **I (ON)** to allow machine operation.

ABOUT THE USE

To restart the machine, act as follows.

1. Press the “Reset” button to reset the machine.
2. Use manual commands to bring all machine organs in the cycle start position (see “ELECTROMECHANICAL CONTROL DESCRIPTION”).
3. Repeat all the automatic cycle start operations.

**6.10. REEL CARRIAGE MOVEMENT (MANUAL MODE)**

Proceed as indicated:

1. Keep buttons **(B-C)** pressed to make reel carriage go upward **(D)**.
2. Hold key **(A)** down to lower reel carriage **(D)**.

When one of the two buttons is released the carriage stops.

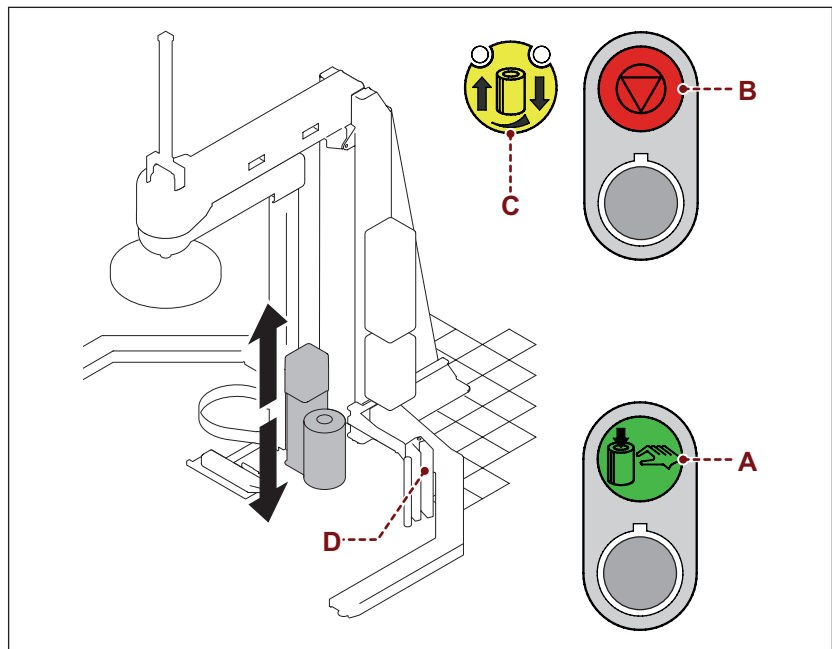

**6.11. TABLE MANUAL ROTATION**

For this operation proceed in the following way.

1. Press the “Table rotation” key to rotate the plate.

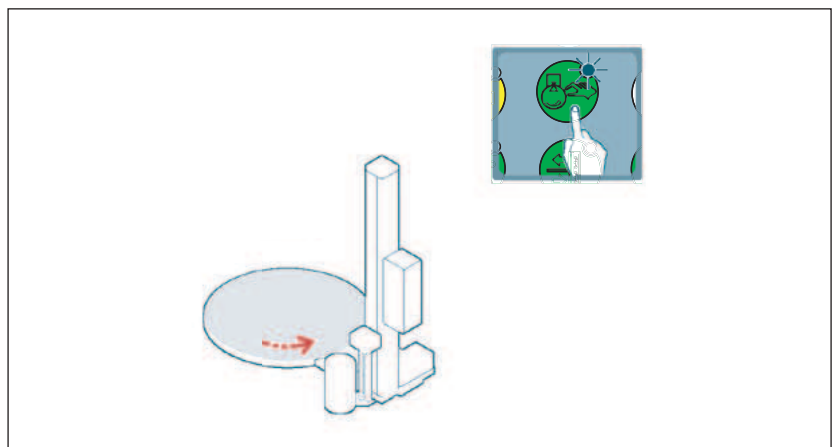

## ABOUT THE USE

**6.12. OPERATION OF THE ARM, PAD AND CLAMP UNITS**

Proceed as indicated.

Pressing on the keys commutes the state of the element that is desired to activate.

- If the arm is rotated backwards, press key **(10)** to rotate it forward.  
If the arm is rotated forward, press key **(10)** to rotate it backward.

**Important**

**If the table is not in phase, the command is not enabled.**

- If the pad is in the backed position, press key **(11)** to set it forward (CW version only).  
If the pad is in the forwarded position, press key **(11)** to set it backward (CW version only).
- If the clamp is closed, press key **(12)** to open it.  
If the clamp is open, press key **(12)** to close it.

**Danger Warning**

**Danger of crushing. Do not put hands inside the clamp unit.**

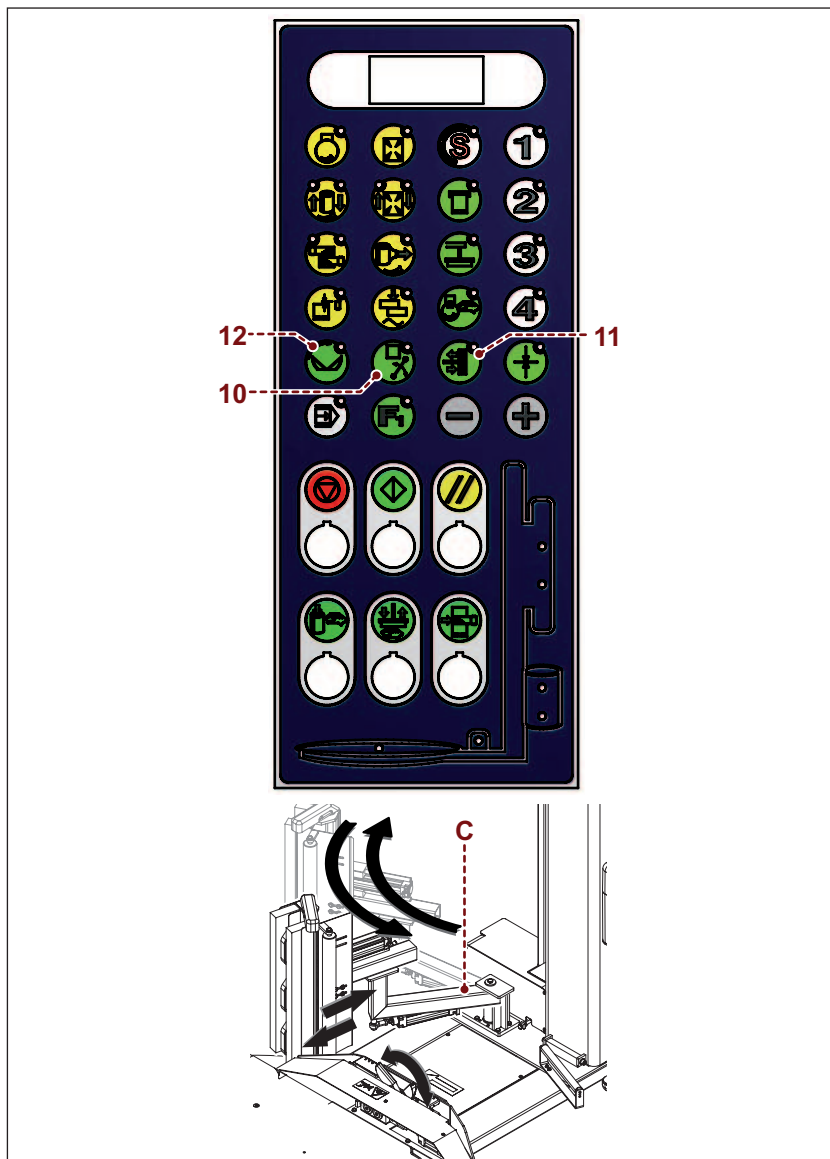

# MAINTENANCE INFORMATION

### 7.1. MAINTENANCE INSTRUCTIONS

- Before performing any operation, the authorised operator must make sure that he/she understood the “Instructions for use”.
- Pay attention to the SAFETY WARNINGS, do not use the machine for UNSPECIFIED PURPOSES and assess the possible RESIDUAL RISKS.
- Carry out the interventions with all the safety devices enabled and wear the DPI provided.
- DO NOT carry out any intervention that is not described in the manual but contact an Assistance Service authorised by the manufacturer.
- DO NOT dump in the environment materials, pollutant liquids and the residues created during the interventions but dispose them according to the standards in force.



**Before performing any maintenance operation, activate all of the security devices provided and evaluate the necessity to adequately inform personnel operating in the near vicinity.**

**It is important to adequately mark nearby areas and prevent the access to all devices that, if activated, could result in sudden dangerous conditions and risks to the safety and health of personnel.**



**Maintenance operations must only be performed with the machine disconnected from the electrical and pneumatic power supplies.**

By regularly checking the working of a number of the more important parts of the machine, subsequent problems can be avoided, and the machine can be kept in perfect working order.

## MAINTENANCE INFORMATION

## 7.2. MAINTENANCE PERIOD TABLE

**Important**

**Keep the machine in maximum working conditions by performing the programmed maintenance operations advised by the manufacturer.**

**Good maintenance achieves the best machine performance, longer machine life and constant observance of the safety regulations.**

Frequency	Component	Type of intervention	Procedure	Reference
Every 40 hours	Machine	General inspection	Clean with a cloth of air jet	–
	Air filtering unit	Condensation control	Condensation discharging	see “Draining the condensate”
		cleanliness	Clean with a blast of air and alcohol	see “Cleaning the filter”
Every 200 hours	Rubber coated rollers	General inspection	Clean with a alcohol dampened cloth	–
	Lifting chain	General inspection	Wash with solvent, let it dry and lubricate	see “Lubrication point diagram”
			Check tension and adjust, if necessary, adjust	see “Reel carriage lifting chain adjustment”
	Table rotation chain	General inspection.	Wash with solvent, let it dry and lubricate	see “Lubrication point diagram”
			Check tension and adjust, if necessary, adjust	see “Table rotation chain adjustment”
Reduction gears and gearmotors	Lubricant level check*	Top-up with a lubricant of the same kind if necessary	see “Lubricants table”	
Every 200 hours	Lifting chain	General inspection	Check for wear and, if necessary, replace. Contattare il servizio assistenza.	–
	Table rotation chain	General inspection	Check for wear and, if necessary, replace. Contact the technical assistance service.	–
	Safety devices	Efficiency control	Replace the damaged components.	–
	Cutting thread	General inspection	Check for wear and, if necessary, replace. Contact the technical assistance service.	see “Replacement of the cutting thread”

\* The reduction gears and gearmotors may be lubricated with either grease, oil, or for life. Reduction gears and gearmotors that are lubricated for life do not need to be topped up and/or replaced.

## MAINTENANCE INFORMATION

<i>Frequency</i>	<i>Component</i>	<i>Type of intervention</i>	<i>Procedure</i>	<i>Reference</i>
Every 5000 hours	Revolving table wheels	General inspection	Check for wear and, if necessary, replace. Contact the technical assistance service	see "Replacing rotating table wheels"
	Carriage lifting wheels	General inspection	Check for wear and, if necessary, replace. Contact the technical assistance service.	–
	Reduction gears and gearmotors	Replacing the lubricant*	Use lubricants with the same characteristics	see "Lubricants table"

- \* The reduction gears and gearmotors may be lubricated with either grease, oil, or for life. Reduction gears and gearmotors that are lubricated for life do not need to be topped up and/or replaced.

MAINTENANCE INFORMATION

**7.3. LUBRICATION POINT DIAGRAM**

Lubricate the illustrated parts at the time and with the methods indicated

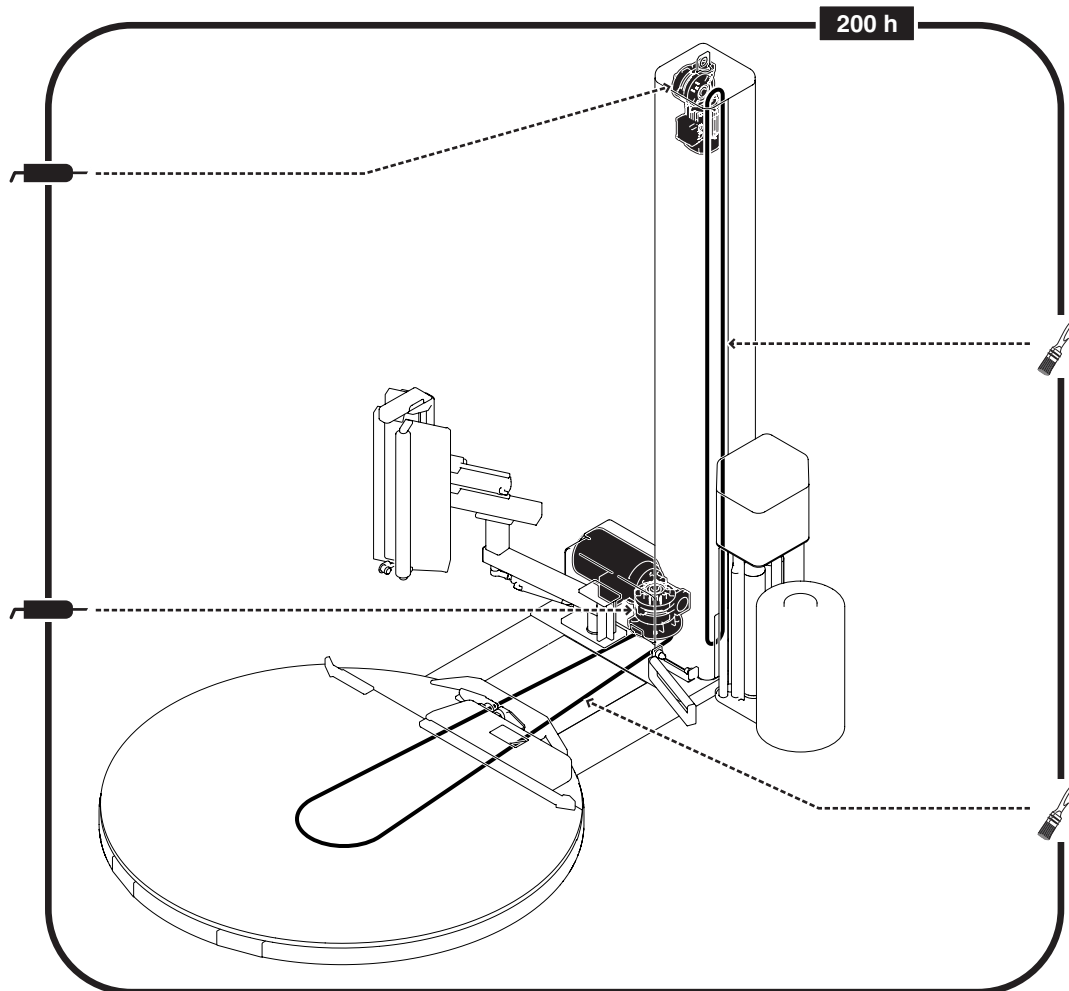

**Key**



Smear with grease.



Check lubricant level.

Do not top-up and/or replace the lubricant in reduction gears and gearmotors lubricated for life.

## MAINTENANCE INFORMATION

**7.4. LUBRICANTS TABLE**

<i>Type of lubricant</i>	<i>Name</i>	<i>Parts to be lubricated</i>
Mineral oil	23°C a 50°C - 320 CST a 40°C	Gear motor
	MELLANA OIL 320 IP	
	SPARTAN EP 320 ESSO	
	BLASIA 320 AGIP	
	MOBILGEAR 632 MOBIL	
	OMALA EP 320 SHELL	
	ENERGOL GR-XP 320 BP	
	32°C a 50°C - 460 CST a 40°C	Worm gear motor
	MELLANA OIL 460 IP	
	SPARTAN EP 460 ESSO	
	BLASIA 460 AGIP	
	MOBILGEAR 634 MOBIL	
	OMALA EP 460 SHELL	
	ENERGOL GR-XP 460 BP	
Grease	TELESIA COMPOUND B IP	Gear and worm gear motor
	STRUCTOVIS P LIQUID KLUBER	
	TOTALCARTER SYOO TOTAL	
Synthetic oil	TELESIA OIL IP	
	SYNTHESO D 220 EP KLUBER	
	BLASIA S 220 AGIP	
Lithium grease	ALVANIA R2 SHELL	Bearings with support
	HL 2 ARAL	
	ENERGREASE LS2 BP	
	BEACON 2 ESSO	
	MOBILIX MOBIL	
Synthetic oil	-5°C / +5°C VG 68 (SAE 20)	Reel carriage lifting chain
	+5°C / +25°C VG 100 (SAE 30)	
	+25°C / +45°C VG 150 (SAE 40)	Table rotation chain
	+45°C / +70°C VG 220 (SAE 50)	

**Important**

**Do not mix oils of different makes and specifications**

MAINTENANCE INFORMATION

**7.5. DRAINING THE CONDENSATE**

Proceed as indicated.

1. Close the tap (A) and control the level of condensation in the container (B).
2. Unscrew, if necessary, the valve (C) to empty condensation.
3. Push the valve (C) up until all condensation is removed.
4. Tighten the valve (C).

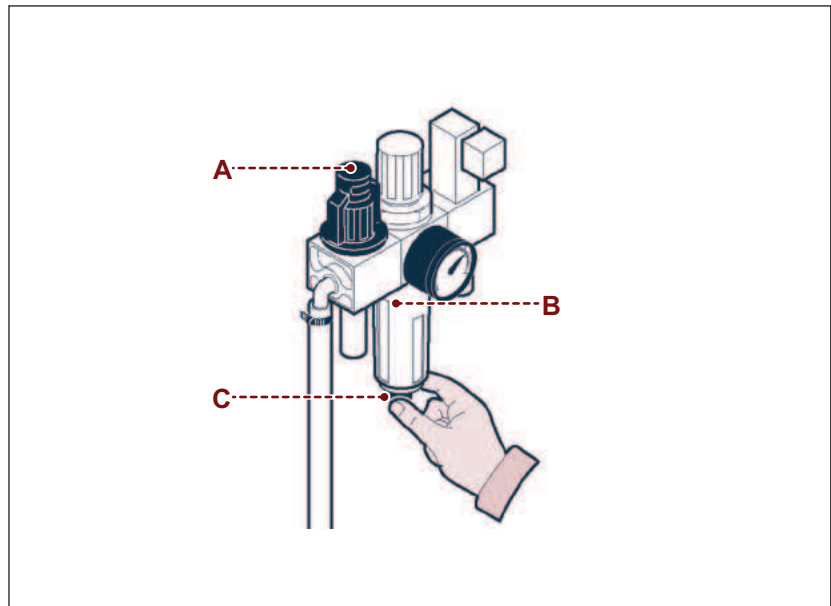

**7.6. CLEANING THE FILTER**

Proceed as indicated.

1. Unscrew the container (B) with the wrench.
2. Detach the filter and clean with compressed air and wash, if necessary with petrol or trichloroethylene.
3. Reassemble the filter and tighten the container (B).

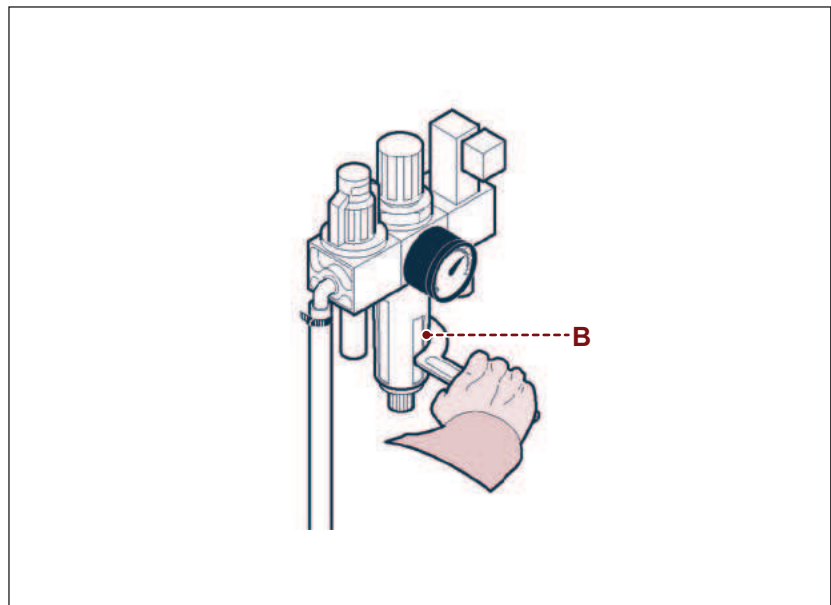

MAINTENANCE INFORMATION

**7.7. CLEANING MACHINE**

General cleaning of the machine is fundamental to guarantee efficiency in the long run.

All the machine must be kept free from dust, dirt and foreign bodies.

The chromed shafts must be cleaned with a cloth and slightly lubricated with a cloth soaked in Vaseline oil.

The parts in plastic material must be cleaned with a slightly damp cloth; do not use alcohol, petrol or solvents.

The control panel is only to be dusted with a dry cloth.

For the cleaning of the parts inside the machine consult our Technical Assistance Service personnel.

## TROUBLESHOOTING

## 8.1. ALARM MESSAGES

In the event of a breakdown during operations the machine stops automatically and alarm messages appear on the display.

The table lists the displayed messages, the type of problem, the cause and possible solutions.

 **Important**

**For these operations a precise technical skill or ability is required; therefore, these operations must be exclusively performed by qualified personnel with certified experience acquired in the specific field.**

<i>Alarm</i>	<i>Inconvenient</i>	<i>Cause</i>	<i>Remedy</i>
<b>E11</b>	Carriage descent safety alarm	An obstacle has been detected along the descent path of the reel carriage	Remove the obstacle and press the "Reset" button
<b>E30</b>	Main inverter alarm	Inverter overload	Eliminate the overload cause. Turn off and turn on the machine again.
<b>E31</b>	Carriage frequency changer alarm	Inverter overload	Eliminate the overload cause. Turn off and turn on the machine again.
<b>E32</b>	Film pre-stretch frequency changer alarm	Inverter overload	Eliminate the overload cause. Turn off and turn on the machine again.
<b>E33</b>	Roller engine speed fast (PVS) inverter alarm	Inverter overload	Eliminate the overload cause. Turn off and turn on the machine again
<b>E41</b>	Serial communication error alarm.	Electronic fault	Contact the Servicing Dept
<b>E42</b>	Cycle parameters initialization alarm	Electronic fault	Contact the Servicing Dept
<b>E43</b>	Machine configuration parameters initialization alarm	Electronic fault	Contact the Servicing Dept
<b>E44</b>	RESET PLC alarm	Electronic fault	Contact the Servicing Dept
<b>E46</b>	Serial communication error alarm (Pre-stretch board)	Electronic fault	Contact the Servicing Dept
<b>E47</b>	Serial communication error alarm (Expansion board I-0).	Electronic fault	Contact the Servicing Dept

## TROUBLESHOOTING

<i>Alarm</i>	<i>Inconvenient</i>	<i>Cause</i>	<i>Remedy</i>
<b>E60</b>	Film end/breakage alarm	The film has broken or reel is empty	Insert the film or replace reel
<b>E61</b>	Table blocked alarm	A breakdown or obstacle block table rotation	Fix the breakdown or remove the obstacle and press the "Reset" button.
<b>E63</b>	Arm alarm	Cutting arm is not in the correct position	Check cutting arm's position. Turn off and turn on the machine again. Activate manual mode (see "Description of buttons (Blue) manual command") and press "Cutting Arm" button to position the arm correctly
<b>E65</b>	Thermal alarm on motors	Motors in fault.	Check motors and consult the electric plant diagram
<b>E70</b>	Function disabled alarm	A function was selected from the control panel that is not enabled for the type of reel carriage installed on the machine or the keyboard block is on	Select another function from the control panel or release the keyboard.
<b>E90</b>	Low tension alarm	Tension is lower than minimum allowed value	Reset tension ratio
<b>E91</b>	High tension alarm	Tension is higher than maximum allowed value	Reset tension ratio

**8.2. LED CHECK**

The boards have the following signaling Leds installed.

<b>LED motherboard</b>		
<i>Led</i>	<i>Clamp</i>	<i>Description</i>
DL2	G2	Not assembled
DL3	G3	Free output
DL4	G7	Clamp ascent
DL5	G8	Clamp descent
DL6	G4	Electromagnetic brake
DL7	--	24 Vdc present
DL8	H2	Product height photoeye
DL9	H5	Turntable phase contact
DL10	H7	Pallet jack emergency photoeye
DL11	H10	Not assembled
DL12	H12	Not assembled
DL13	H13	Not assembled
DL14	L1	Not assembled
DL15	L5	Safety alarm at carriage base plate
DL16	L6	Film unwrapping button
DL17	L7	Carriage limit stop high

## TROUBLESHOOTING

<i>Led</i>	<i>Clamp</i>	<i>Description</i>
DL18	L9	Carriage limit stop low
DL20	--	Carriage ascent
DL21	--	Carriage descent
DL22	--	Turntable rotation

<b>LED expansion board</b>		
<i>Led</i>	<i>Clamp</i>	<i>Description</i>
DL14	I11	Arm forward limit stop
DL15	I12	Arm backward limit stop
DL16	I13	
DL17	I14	Magneto-thermic alarm
DL18	I15	
DL19	I16	
DL20	I17	
	A01	
	A02	
	UA0	
	A03	
	A04	
DL1	U00	Turntable engine brake
DL2	U01	Film sealing
DL3	U02	Film cutting
DL4	U03	
DL5	U04	
	A05	
	A06	
DL6	U05	Arm forward electro-valve
DL7	U06	Buffer forward electro-valve
DL8	U07	Clamp closing electro-valve
DL9	U10	Air venting electro-valve
	GP5	
DL11	U15	
DL12	U16	
DL13	U17	

## SPARE PARTS REPLACEMENT INFORMATION

### 9.1. RECOMMENDATIONS FOR REPLACING PARTS

- Carry out the interventions with all the safety devices enabled and wear the DPI provided.
- DO NOT carry out any intervention that is not described in the manual but contact an Assistance Service authorised by the manufacturer.
- DO NOT dump in the environment materials, pollutant liquids and the residues created during the interventions but dispose them according to the standards in force.



#### **Important**

**Before carrying out any replacement activate all safety devices provided for, and assess if it is necessary to inform operating personnel and the personnel nearby.**

**It is important to adequately mark nearby areas and prevent the access to all devices that, if activated, could result in sudden dangerous conditions and risks to the safety and health of personnel.**

**When replacing worn parts, use only original replacement parts.**

**The Manufacturer is not responsible for any damage to property or injuries to people caused by the use of non-genuine spare parts or which may result from repairs not authorised by the Manufacturer.**

**When ordering new parts, follow the instructions given in the spares catalogue.**

SPARE PARTS REPLACEMENT INFORMATION

**9.2. REPLACING ROTATING TABLE WHEELS**

Proceed as indicated.

1. Loosen and remove screws 7 and disassemble the top plate.
2. Loosen the screws (A).
3. Assemble the eyebolts (B) on the rotating table (C).
4. Lift the table and place it on the floor.
5. Replace the wheels (D).
6. Position the table on the base and fasten it with the screws.

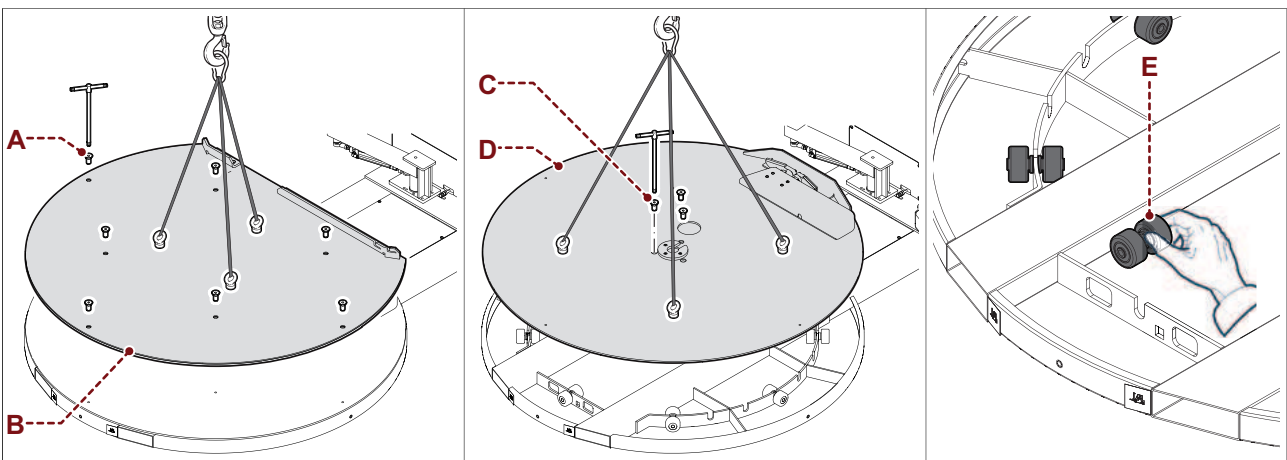

**9.3. REPLACEMENT OF THE CUTTING THREAD**

Proceed as indicated.

1. Remove cover.
2. Loosen the fastening screws (A).
3. Position the new thread (B).
4. Tighten the screws (A) when finished.

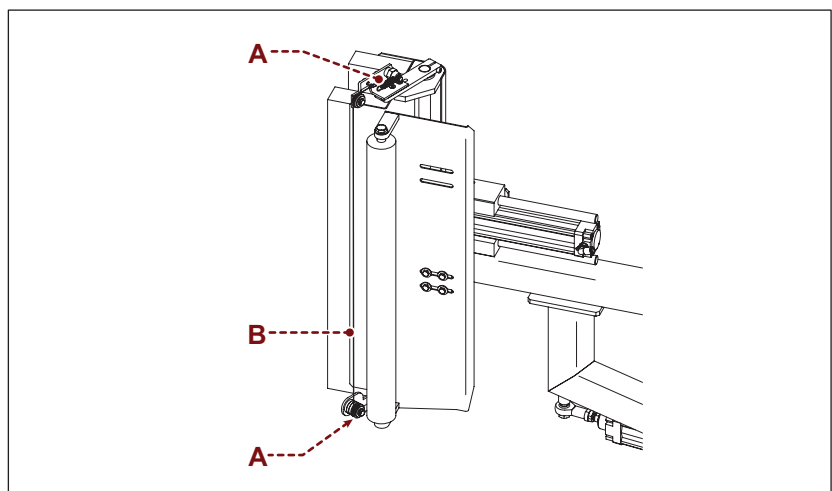

## SPARE PARTS REPLACEMENT INFORMATION

### 9.4. FUSE REPLACEMENT

**Note: Work that must be performed mandatorily by a specialised operator.**

The fuses are located inside the control panel and are reachable by opening the door with proper access keys.

1. Rotate main switch in position "0" (off) before going inside the compartment.
2. Disconnect the machine from the mains by unplugging it

Refer to wiring diagram supplied along with the machine.

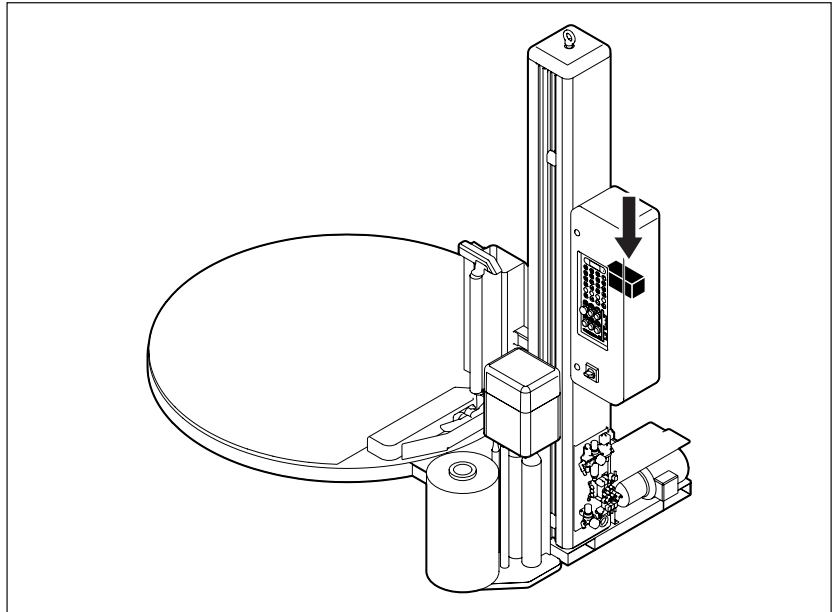

**! Danger Warning**

**Make sure that the amperage of the new fuse is the same as that of the one to be replaced.**

**! Danger Warning**

**Do not bring in water, oil or dirt inside the electric panel.**

**! Danger Warning**

**When closing the door, be careful not to damage the cables and wiring.**

### 9.5. LIST OF ESSENTIAL SPARE PARTS

List of the spare parts of easy wear and of which it would be necessary to have available to avoid long operation stops of the machine. For ordering, contact your local Dealer and refer to the spare parts catalogue.

- no. 8 Bed wheels.
- no. 8 Carriage wheels.
- no. 1 Cutting thread.
- no. 1 Drive belt (only for carriages PDS-PVS).
- no. 1 Carriage clutch (only for carriages PDS-PVS).

**i Important**

**Replace the worn parts with original parts. Use the oils and greases specified in the manual. All these measures may guarantee the expected operating and safety level of the machine.**

SPARE PARTS REPLACEMENT INFORMATION

**9.6. MACHINE DISPOSAL AND SCRAPING**

 **Important**

**These operations must be performed by specialised personnel in accordance with the standards in force on workplace safety.**

**Do not scatter non biodegradable products, lubricant oil and non-iron components (rubber, PVC, resins, etc.) in the environment.).**

**Discharge them in compliance with current regulations.**

Useful information for the disposal of machines and machine parts.

Scrapping must be performed by qualified personnel.

Construction material:

- Low-density linear polyethylene (L.L.D.PE).
- Steel, aluminium and cast-iron.
- Copper and silver in the electrical/electronic components.
- Rubber, resins and fibres.

None of the component materials is harmful or poisonous.

Special care must be taken when disposing of leftover oil or grease from the motor reduction units.

Do not dump these materials in the environment and do not dispose of them as household refuse.



ENCLOSED DOCUMENTATION

**10.2. WARRANTY CONDITIONS**

ROBOPAC S.p.A. pledges, within the limits described herein, to replace or repair, at no charge, the parts that become defective during the 12 (twelve) months following the date indicated on the company's shipping documents.

To utilise the warranty, the user must immediately notify the company that a defect exists, always referring to the machine serial number.

ROBOPAC S.p.A., in its final judgement, will decide whether to replace the defective part or request it to be shipped for tests and/or repairs.

By replacing or repairing the defective part, ROBOPAC S.p.A. fully complies with its warranty obligations and will be released from all liabilities and obligations relative to transport, travel and hotel expenses for technicians and installers.

ROBOPAC S.p.A. will never be held responsible for any losses due to lack of production or injuries to persons or damage to things caused by malfunctions or forced suspension in using the machine covered by the warranty.

The warranty does not cover:

- damage caused by transport;
- damage due to incorrect installation;
- improper use of the machine or negligence;
- tampering or repairs by unauthorised personnel;
- lack of maintenance;
- parts subject to normal wear and tear.

For purchased components and parts, ROBOPAC S.p.A. offers the user the same warranty conditions that the company obtains from the suppliers of the aforementioned components and/or parts.

ROBOPAC S.p.A. does not guarantee the conformity of machines to current standards in countries that are not part of the European Union.

Concerning any adjustments to standards of the country in which the machine is installed, the user will be fully responsible for the changes made, releasing ROBOPAC S.p.A. from any obligation and/or liability relative to any claims that may be submitted by third parties due to non-compliance with the referenced standards.