



Via Fabrizio da Montebello, 81
47892 Gualdicciolo
Tel +378 0549 910511 Fax +378 0549 908549
Repubblica di San Marino

Modello Macchina
Machine Model
Maschine Modell
Modele de la Machine
Modelo Maquina

ORBIT 4-6-9.125

Numero Matricola
Machine Serial Number
Maschine Kennnummer
Numero de Matricule
Numero de Matricula

7450305637

Tensione di alimentazione
Power Supply Voltage
Spannungsversorgung
Voltage electrique
Tension de Alimentacion

400 V 50 Hz
3 Ph + N

Potenza Installata
Installed Power
Installierte Leistung
Puissance installée
Potencia Instalada

1,5-1,9 kW

Corrente Assorbita
Absorbed Current
Stromaufnahme
Absorption Electrique
Absorcion

4,5-6 A

For Robopac Use Only

Codice quadro elettrico

7450305637

Indice Modifica

00

Numero Bolla

3000000001997

Costruire secondo specifica tecnica 50.1.1
Controllare con scheda di collaudo

7450305637

Elaborato da

Guerra A.

Verificato da

Stella S.

Approvato da

Laghi P.



Description

Copertina
Cover sheet

Code

3709303472

Date

06/12/2017

Total

30

Prev

Subs

2

Page

1

Sommario delle pagine

Table of contents

Impianto Higher-level function	Luogo di montaggio Mounting location	Pagina Page	Descrizione pagina Page description	Campo aggiuntivo delle pagine supplementary page field	Data Date	Elaboratore Edited by
		1	Copertina Cover sheet		17/10/2017	aguerra
		2	Sommario delle pagine : /1 - /100 Table of contents : /1 - /100		17/10/2017	aguerra
		2.1	Sommario delle pagine : /110 - /230 Table of contents : /110 - /230		17/10/2017	aguerra
		4	Targhetta quadro elettrico Plate control cabinet		13/10/2016	aguerra
		5	Distinta articoli Parts list		16/10/2017	aguerra
		5.1	Distinta articoli Parts list		17/10/2017	aguerra
		10	ALIMENTAZIONE POWER SUPPLY		17/10/2017	aguerra
		20	Circuito di potenza Power circuit		17/10/2017	aguerra
		30	Circuito di potenza Power circuit		17/10/2017	aguerra
		40	Circuito Ausiliario Auxiliary Circuit		17/10/2017	aguerra
		50	Circuito Ausiliario Auxiliary Circuit		17/10/2017	aguerra
		60	Alimentazione Plc Plc Power Supply		17/10/2017	aguerra
		70	Ingressi digitali Digital Inputs		17/10/2017	aguerra
		80	Ingressi digitali Digital Inputs		17/10/2017	aguerra
		90	Ingressi digitali Digital Inputs		17/10/2017	aguerra
		100	Uscite Digitali Digital Outputs		17/10/2017	aguerra

Sommario delle pagine

Table of contents

Impianto Higher-level function	Luogo di montaggio Mounting location	Pagina Page	Descrizione pagina Page description	Campo aggiuntivo delle pagine supplementary page field	Data Date	Elaboratore Edited by
		110	Uscite Digitali Digital Outputs		17/10/2017	aguerra
		120	Pannello Operatore Operator Panel		17/10/2017	aguerra
		130	Layout armadio elettrico Panel layout		17/10/2017	aguerra
		210	Sommario Impianto CanOpen Can Open Connection		17/10/2017	aguerra
		221	Sommario cavi Cable overview		17/10/2017	aguerra
		222	Morsettiera Neutro Neutral TerminalBoard		17/10/2017	aguerra
		223	Morsettiera Sensori Sensors Terminalboard		17/10/2017	aguerra
		224	Morsettiera Sensori Sensors Terminalboard		16/10/2017	aguerra
		225	Morsettiera Segnali Signals TerminalBoard		17/10/2017	aguerra
		226	Morsettiera Segnali Signals TerminalBoard		17/10/2017	aguerra
		227	R-Connect R-Connect		17/10/2017	aguerra
		228	Morsettiera Sicurezza Safety Terminalboard		17/10/2017	aguerra
		229	Morsettiera Ausiliaria Auxiliary Terminalboard		17/10/2017	aguerra
		230	Morsettiera Elettrovalvole Pneumatic Terminalboard		17/10/2017	aguerra

		S/N	7450305637	
		Mod.	ORBIT 4-6-9.125	
		w.d.		
N.		Ref.		 Kg
Un	400 V	v	Ph	3 Ph + N
			f	50 Hz
In	4,5-6	A	Ik	10
			Ka	
Data			By	

Distinta articoli

Parts list

SEF	Designazione Designation	Numero tipo Type number	Produttore Manufacturer	Quantità Quantity	Codice Code	Pagina Page
-U0	Filtro alimentazione Main filter	16S5-1AH1-T	Comestero Sistemi	1	0500300007	/10.1
-QS1	Sezionatore 600V 40A 4P Switch-disconnector 600V 40A 4P	OT40FT4N2	ABB	1	0099000038A	/10.1
-QS1	Polo aggiuntivo di terra 40A Protective earth terminal 40A	OTPE40FD	ABB	1	0099000398	/10.1
-QS1	Maniglia retroquadro GRI-NER Handle for door mounted GY-BK	OHBS2RJ	ABB	1	0001310774	/10.1
-R2	Resistenza di frenatura Brake Resistor	RFC-60-300	Mitsubishi	1	0001348723	/20.1
-U1	Inverter Variable speed drives	ATV320U07M2C	Schneider Electric	1	1730300031	/20.2
-F1	Base per fusibile 10,3 X 38 Base for fuse 10,3 X 38	10,3X38 1P		1	0001352427E	/20.2
-F1	Fusibile Cilindrico 10,3x38 GG 10A 500VAC	10,3x38 GG 10A 500VAC		1	0001304235H	/20.2
-SP1	Adattatore Mod. RJ45 CanOPen Adapter Mod. RJ45 CANopen	TCSCTN023F13M03	Schneider Electric	1	1070300006	/20.8
-U2	Inverter Variable speed drives	ATV320U04M2C	Schneider Electric	1	00L0362221	/30.2
-F2	Base per fusibile 10,3 X 38 Base for fuse 10,3 X 38	10,3X38 1P		1	0001352427E	/30.3
-F2	Fusibile Cilindrico 10,3x38 GG 8A 500VAC Cylindrical Fuse 10,3x38 GG 8A 500VAC	10,3x38 GG 8A 500VAC		1	0001304220	/30.3
-F4	Relè Termico 1-1,6 A thermal overload relay for motor TeSys 1-1,6 A	LRD06	Schneider Electric	1	0001352465	/30.3
-F5	Relè Termico 1-1,6 A thermal overload relay for motor TeSys 1-1,6 A	LRD06	Schneider Electric	1	0001352465	/30.5
-SP2	Adattatore Mod. RJ45 CanOPen Adapter Mod. RJ45 CANopen	TCSCTN023F13M03	Schneider Electric	1	1070300006	/30.9
-R3	Resistenza di Terminazione	TCSCAR013M120	Schneider Electric	1	1340300002	/30.9
-G1	Power supply 60W, in: 1 phase 100-240VAC/90-350VDC, out: 24VDC/2.5A Power supply 60W, in: 1 phase 100-240VAC/90-350VDC, out: 24VDC/2.5A	S8VKG06024	Omron	1	00L0354044	/40.1
-S10	Pulsanti per arresto d'emergenza Emergency-Stop actuator, non-illuminated	M22-PV	Eaton Moeller	1	0099001046	/50.1
-S10	Supporto per contatti Fixing adapter	M22-A	Eaton Moeller	1	0001300700A	/50.1
-S10	Elementi di contatto, 1NC, Fissaggio frontale, Cage clamp Contact element, 1N/C, Front fixing, Cage clamp	M22-CK01	Eaton Moeller	2	0001300027C	/50.1
-S10	Elementi di contatto, 1NA, Fissaggio frontale, Cage clamp Contact element, 1N/O, Front fixing, Cage clamp	M22-CK10	Eaton Moeller	1	0001300024F	/50.1
-W5	Cavo M12 5Poli Fem 5,0m M12 Cable 5P Fem 5,0m	M12 5P FEM 5,0M		1	0099000895	/50.1
-S6	Fincorsa a cerniera Hinge Limit switch	HP-AA052D-KSM	Pizzato	1	00L0335221	/50.1
-S6	Cerniera complementare Additional Hinge	HC-AA	Pizzato	1	00L0298253	/50.1
-W5.1	Cavo M12 5Poli Fem 5,0m M12 Cable 5P Fem 5,0m	M12 5P FEM 5,0M		1	0099000895	/50.1
-S6.1	Fincorsa a cerniera Hinge Limit switch	HP-AA052D-KAM	Pizzato	1	0202300007	/50.2
-S6.1	Cerniera complementare Additional Hinge	HC-AA	Pizzato	1	00L0298253	/50.2
-K1	Contattore Aux. CAD-323BD 3NO + 2 NC contactor TeSys CAD-323 - 3 NO + 2 NC	CAD323BD	Schneider Electric	1	0001303906B	/50.4
-S11	Pulsante, piatto, blu, ad impulso Pushbutton actuator, flush, blue, spring return	M22-D-B	Eaton Moeller	1	0001300696B	/50.5
-S11	Supporto per contatti Fixing adapter	M22-A	Eaton Moeller	1	0001300700A	/50.5
-S11	Elementi di contatto, 2NA, Fissaggio frontale, Cage clamp Contact element, 2S, Front fixing, Cage clamp	M22-CK20	Eaton Moeller	1	0001318807L	/50.5
-W32	Cavo E.V. 5,0m Cable 5,0m	CE11-23A2R624-5000-0		1	0001304108L	/50.6
-A1	Logica Programmabile Plc	TM241CEC24T	Schneider Electric	1	1373300008	/60.1
-A3	I/O di espansione M241 M241 Expansion I/O	TM3DI8	Schneider Electric	1	1371300014	/60.5
-W10	Cavo M12 4Poli Fem 5,0m M12 Cable 4P Fem 5,0m	M12 4P FEM 5,0M		1	0001313474	/70.2
-S1	Sensore induttivo, M18 PNP NO Proximity switch, M18 PNP NO	AK1/AP-1A	Microdetectors	1	0001300299	/70.2
-S2 Opt	Sensore induttivo, M18 PNP NO Proximity switch, M18 PNP NO	AK1/AP-1A	Microdetectors	1	0001300299	/70.4
-S2 Opt	Lamiera Tastatore Probe Plate		Robopac	1	4940300983	/70.4

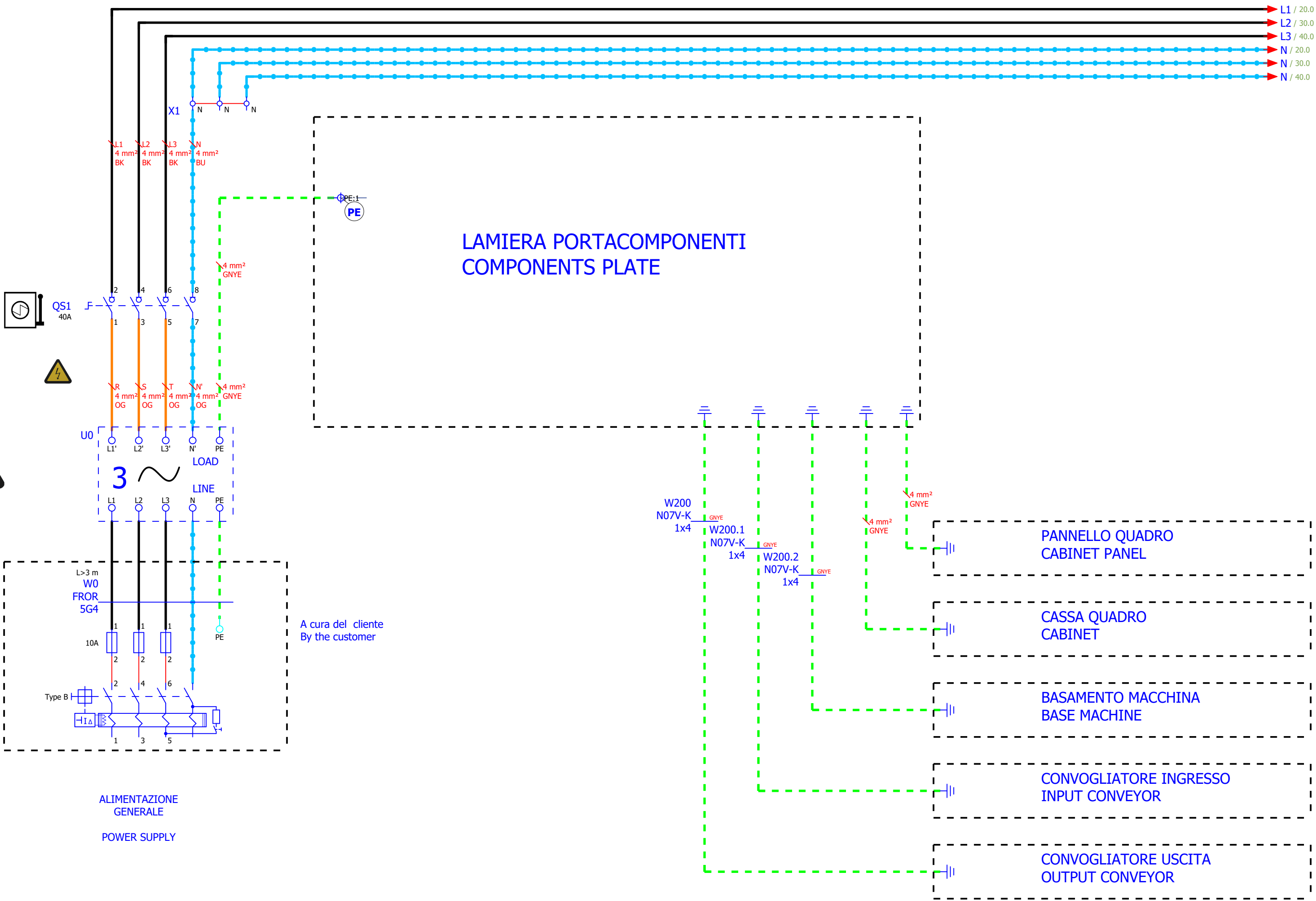

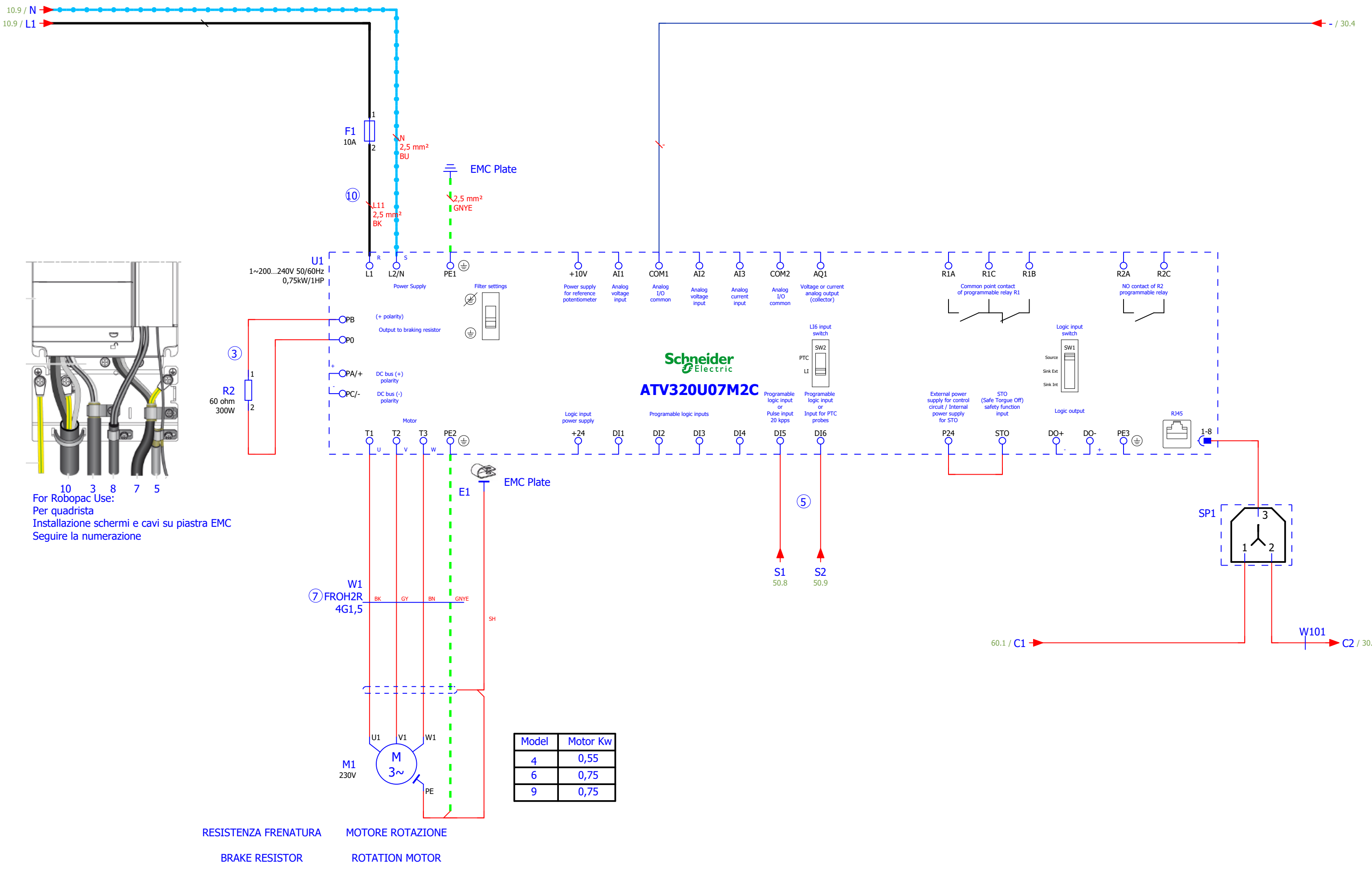

For Robopac Use:
Per quadrista
Installazione schermi e cavi su piastra EMC
Seguire la numerazione

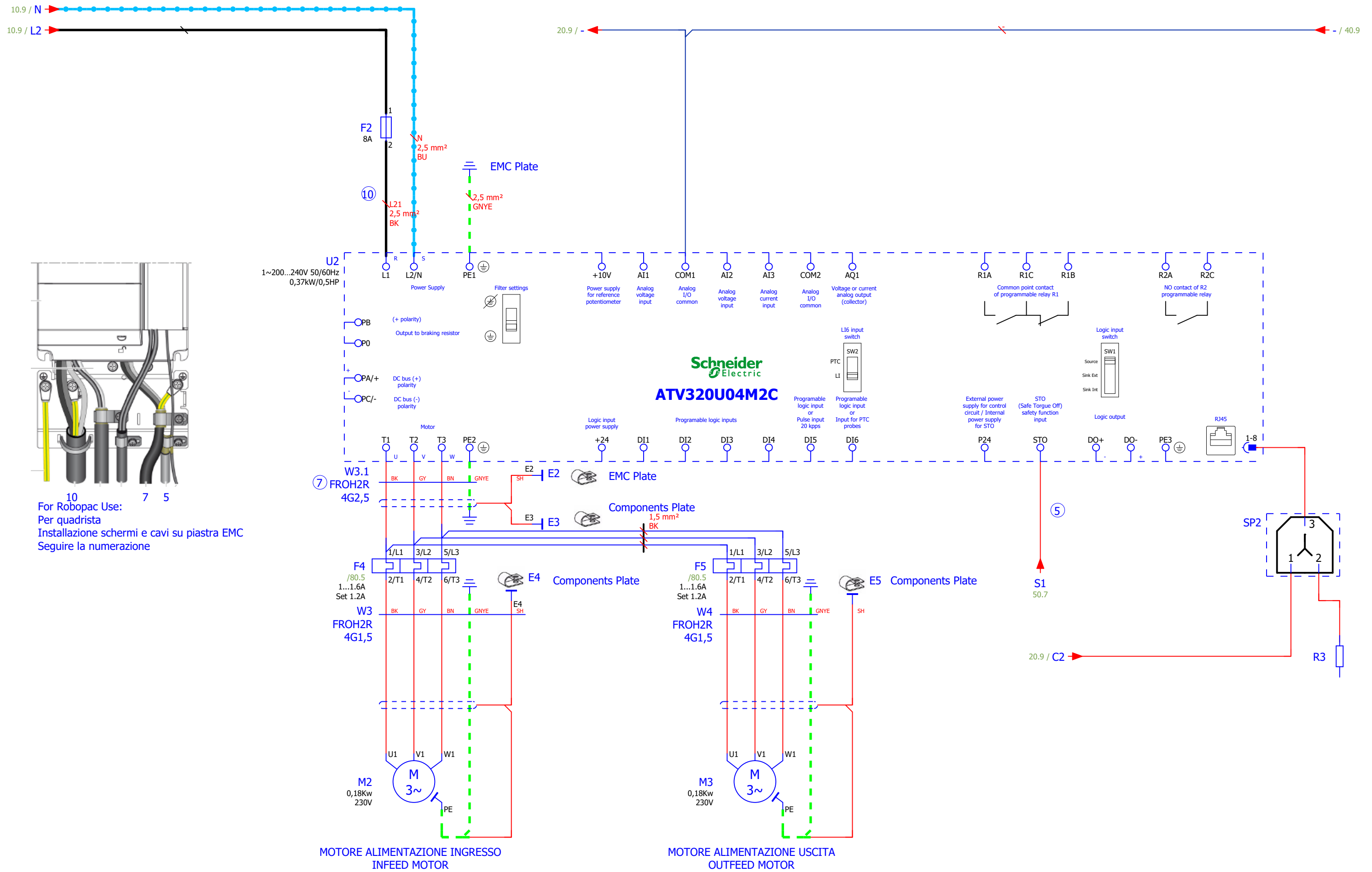

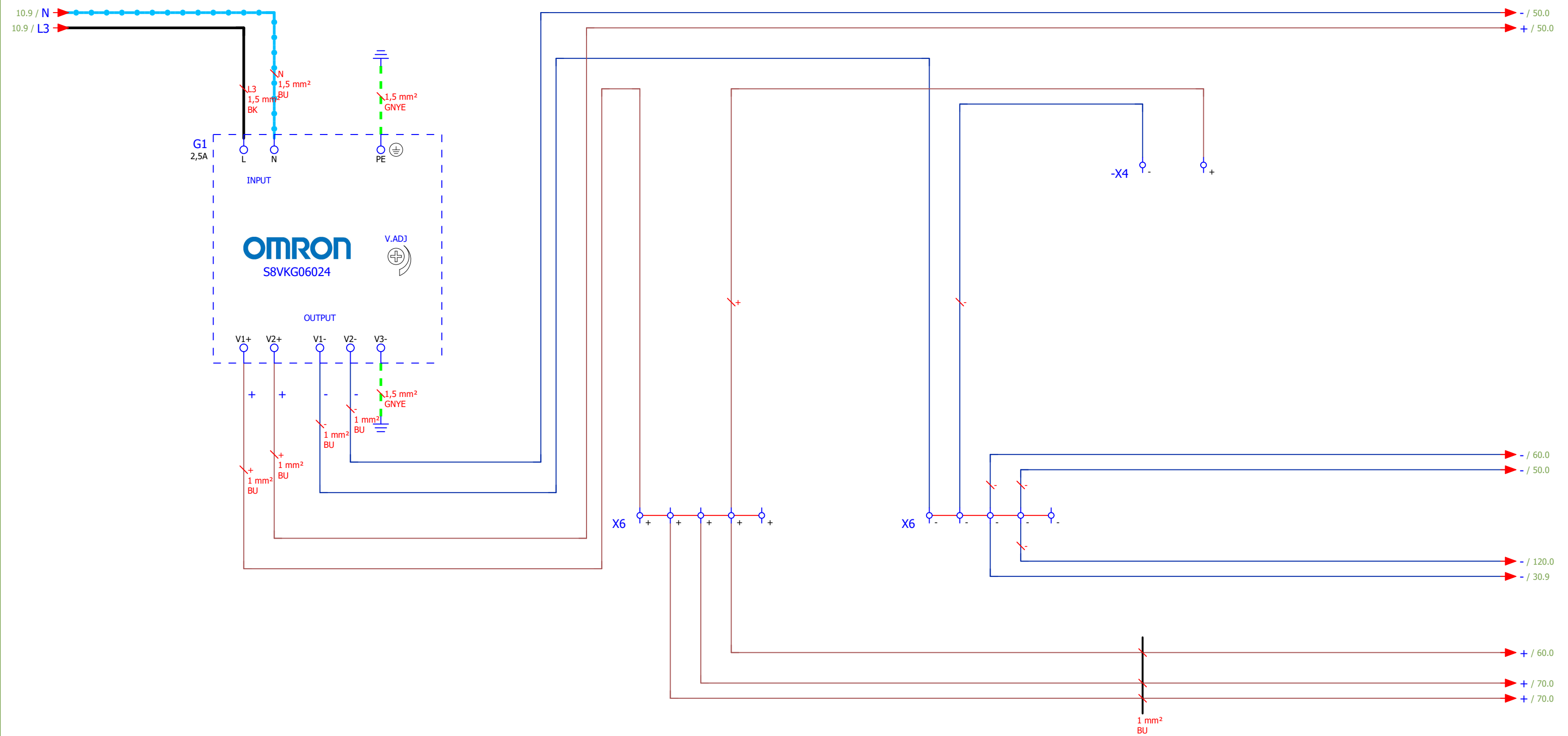

Alimentazione ausiliaria
Auxiliary power supply

Predisposizione R-Connect
R-Connect

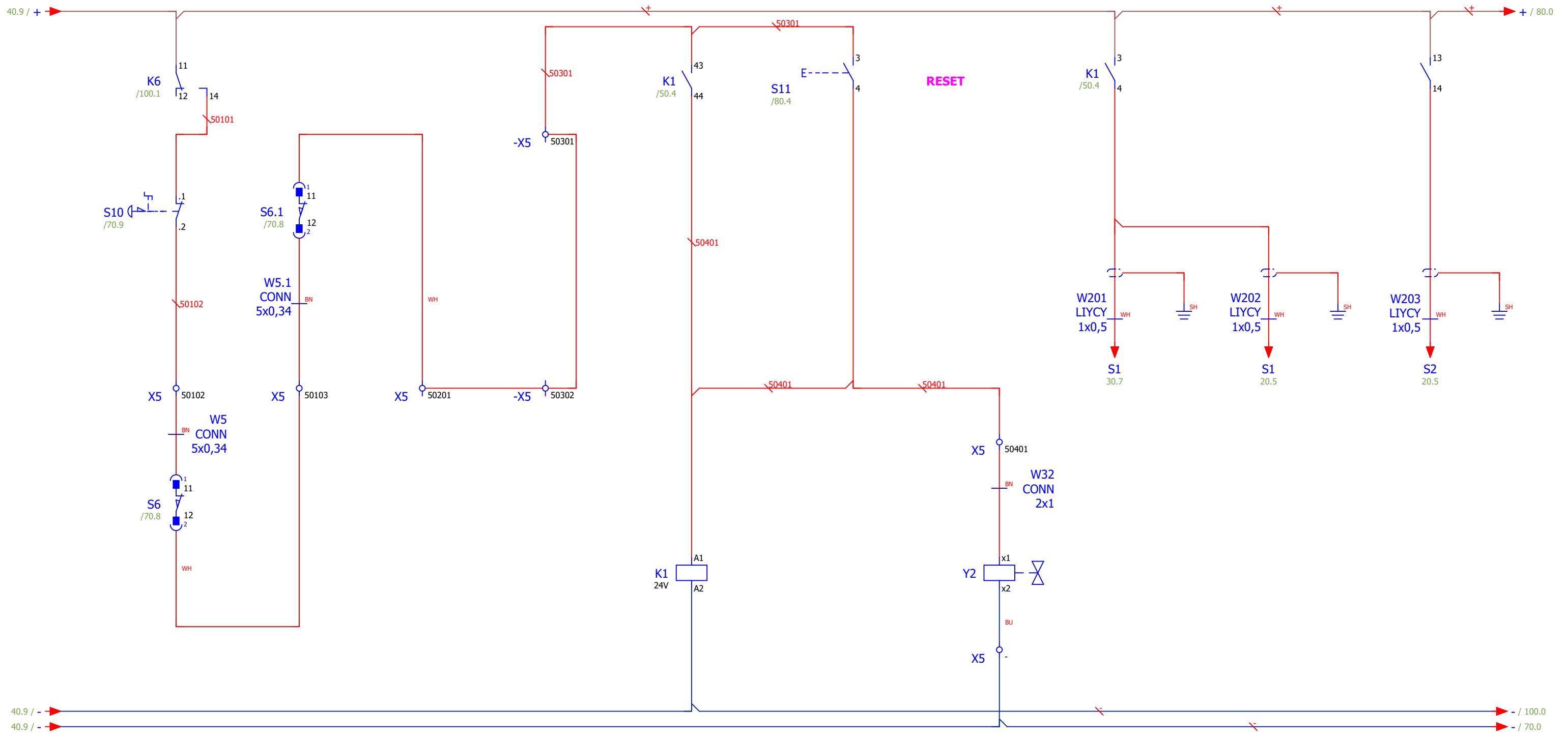

Catena Emergenza
Emergency Chain

Emergenza
Emergency

Scarico Aria
Air Discharge

STO Inverters
Inverters STO

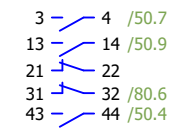

Description
**Circuito Ausiliario
Auxiliary Circuit**

Code	3709303472	Date	06/12/2017	Total	30	Prev	40	Subs	60	Page	50
Machine	ORBIT 4-6-9.125										

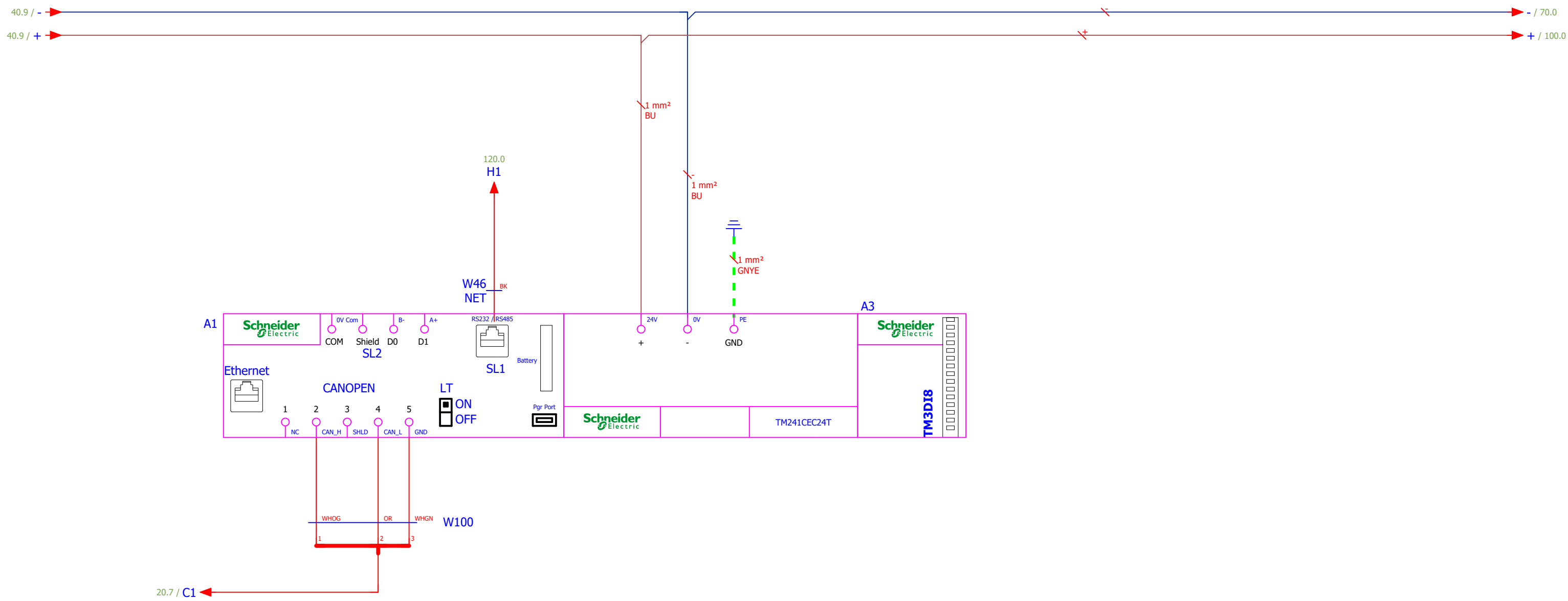

Comunicazione Plc
Plc Communication

Alimentazione Plc
Plc power supply

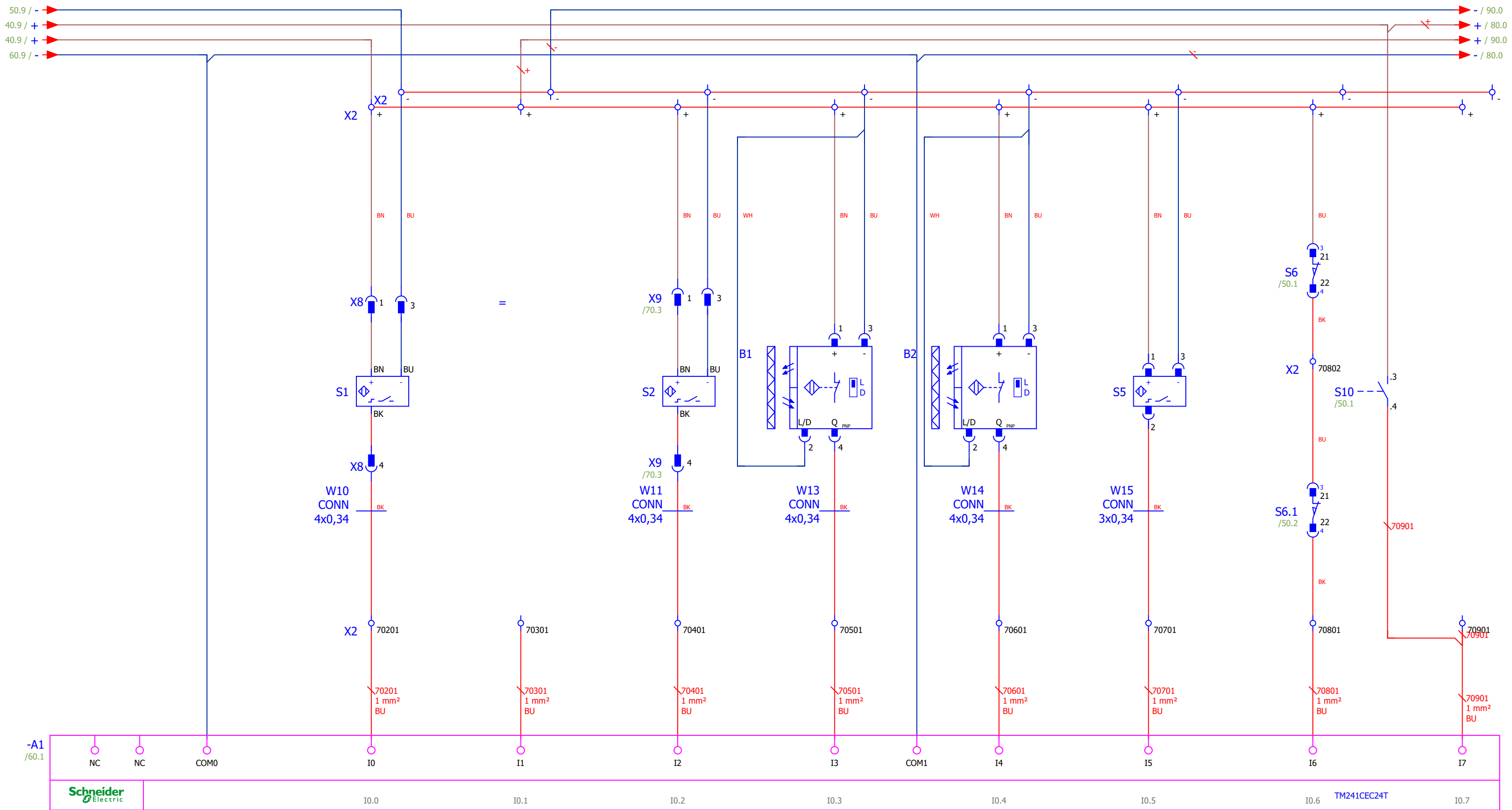

Fase Rotazione
Rotation Phase

Rottura Film
Film Break
Opt.

Ingresso Prodotto
Product Infeed

Uscita Prodotto
Product Outfeed

Pinza Indietro
Clamp Backward

Sicurezza Porte
Door Safety

Emergenza
Emergency

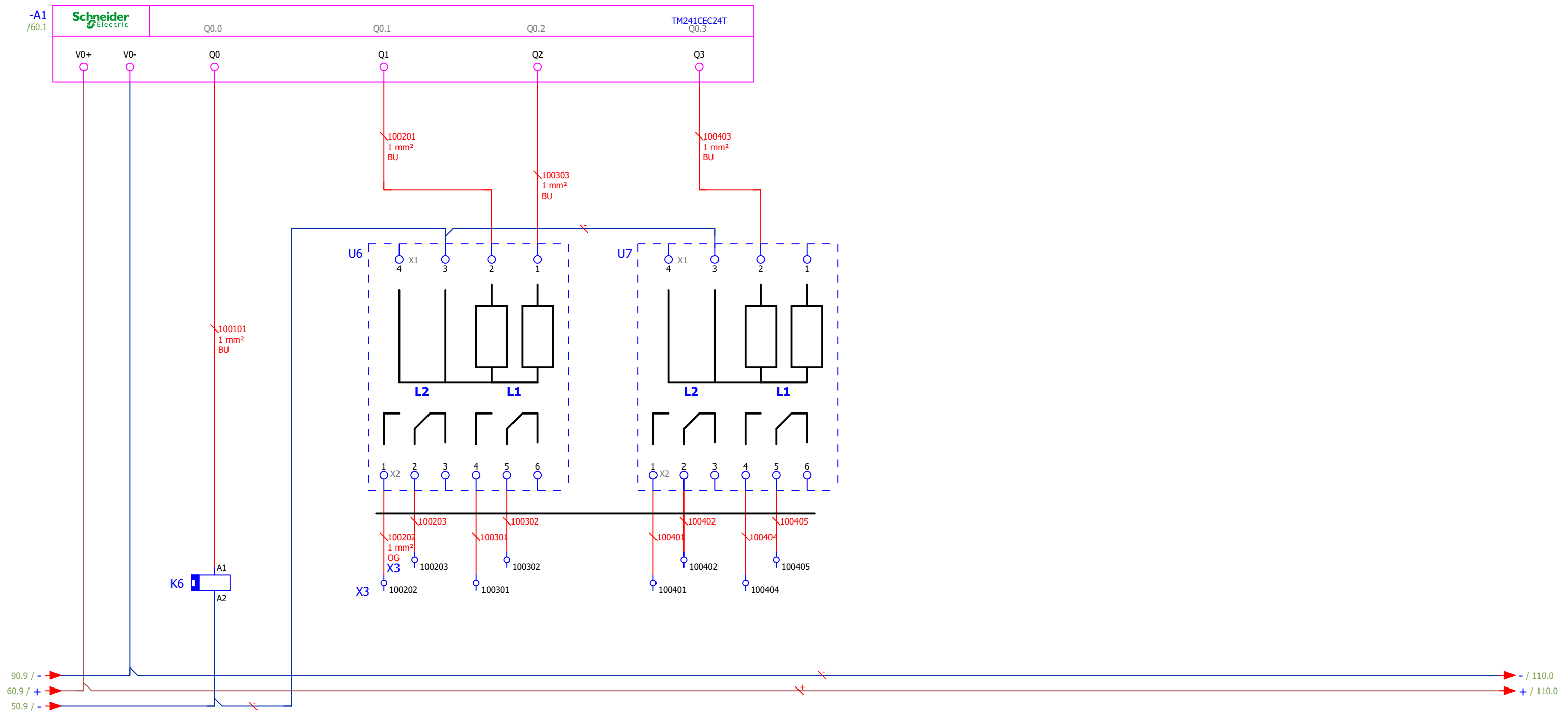

14
12 11 /50.1

Allarme Plc
Plc Alarm

Prodotto Pronto per Uscita
Ready Product To Output

Pronto a Ricevere in Entrata
Ready For Input

Fine Entrata Prodotto
Input Product End



Description: **Uscite Digitali Digital Outputs**

Code	3709303472	Date	06/12/2017	Total	30	Prev	90	Subs	110	Page	100
Machine	ORBIT 4-6-9.125										

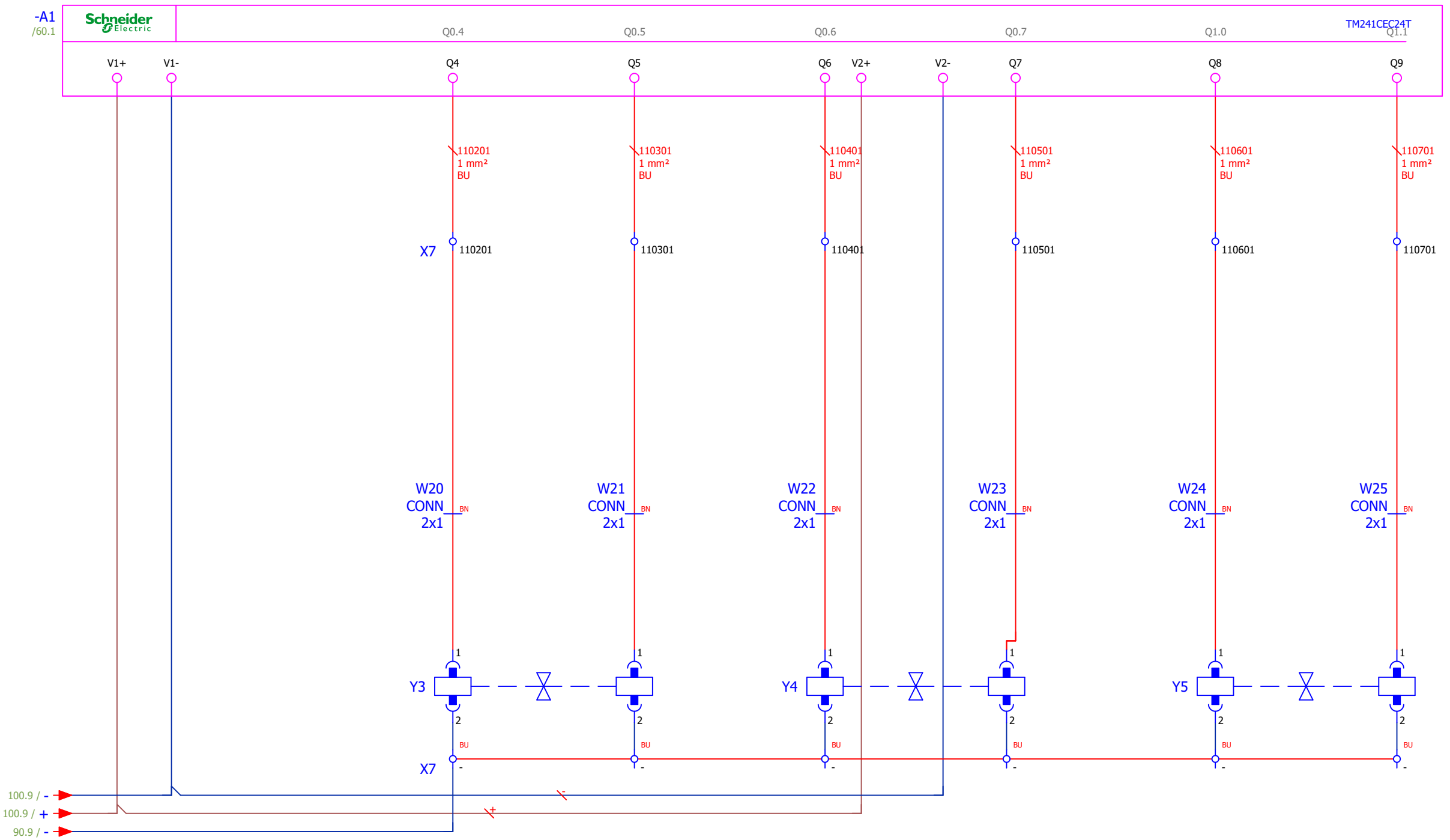

Pinza Avanti
Forward Clamp

Pinza Chiusa
Backward Clamp

Salita Pressore
Ingresso
Presser Rise
Input

Discesa Pressore
Ingresso
Presser Fall
Input

Salita Pressore
Uscita
Presser Rise
Output

Discesa Pressore
Uscita
Presser Fall
Output

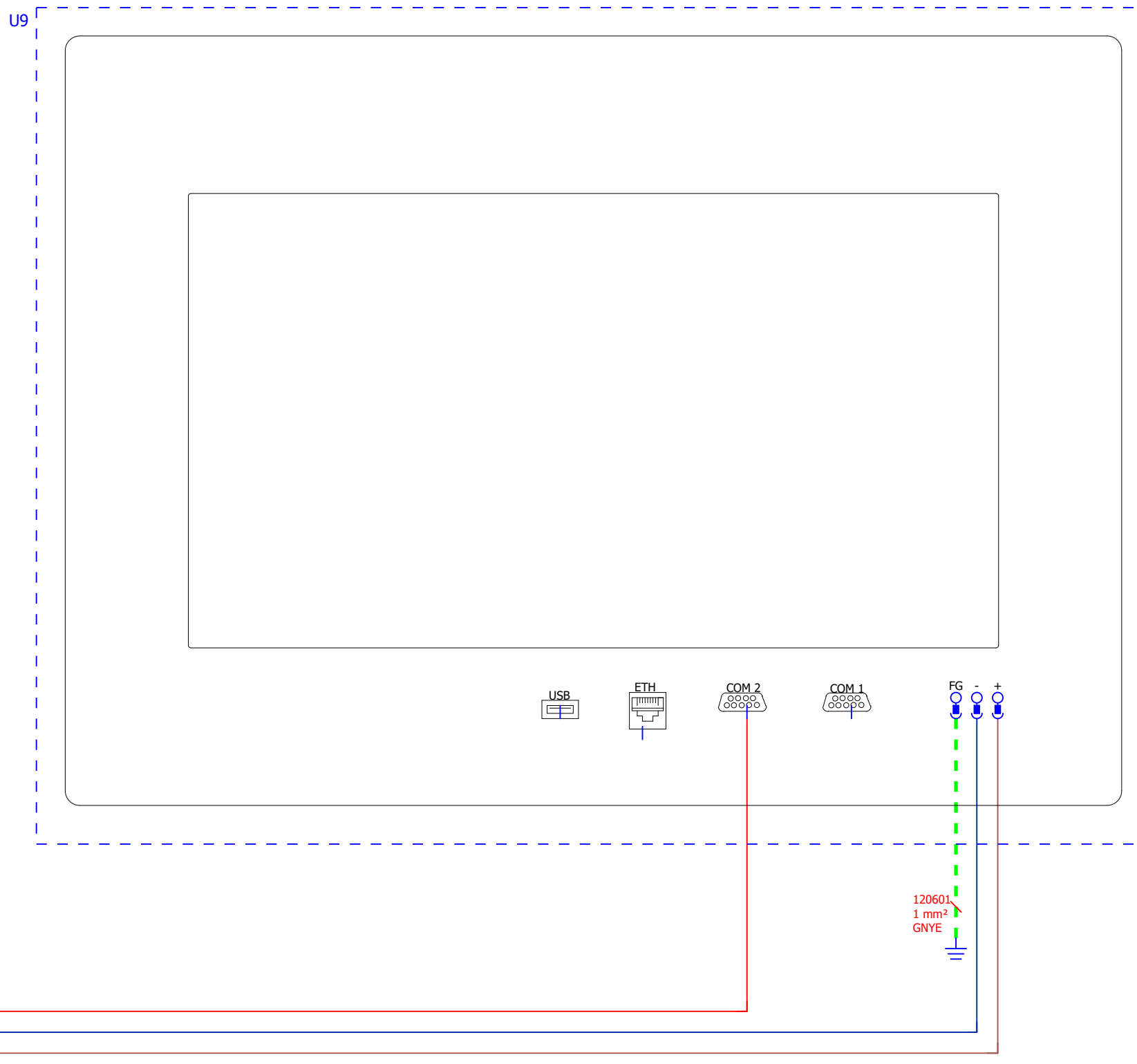

60.3 / H1
40.9 / -
90.9 / +

120601
1 mm²
GNYE

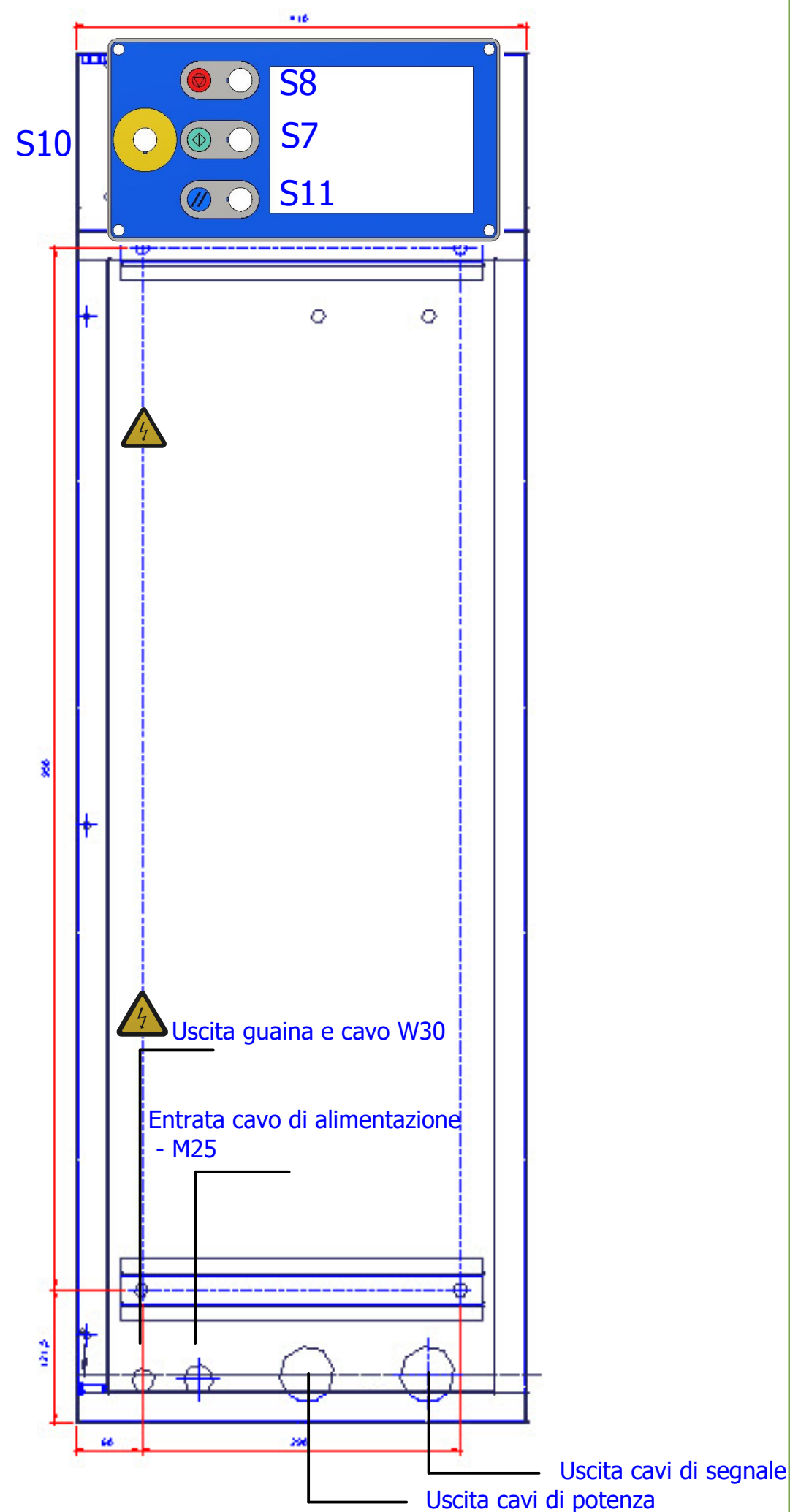
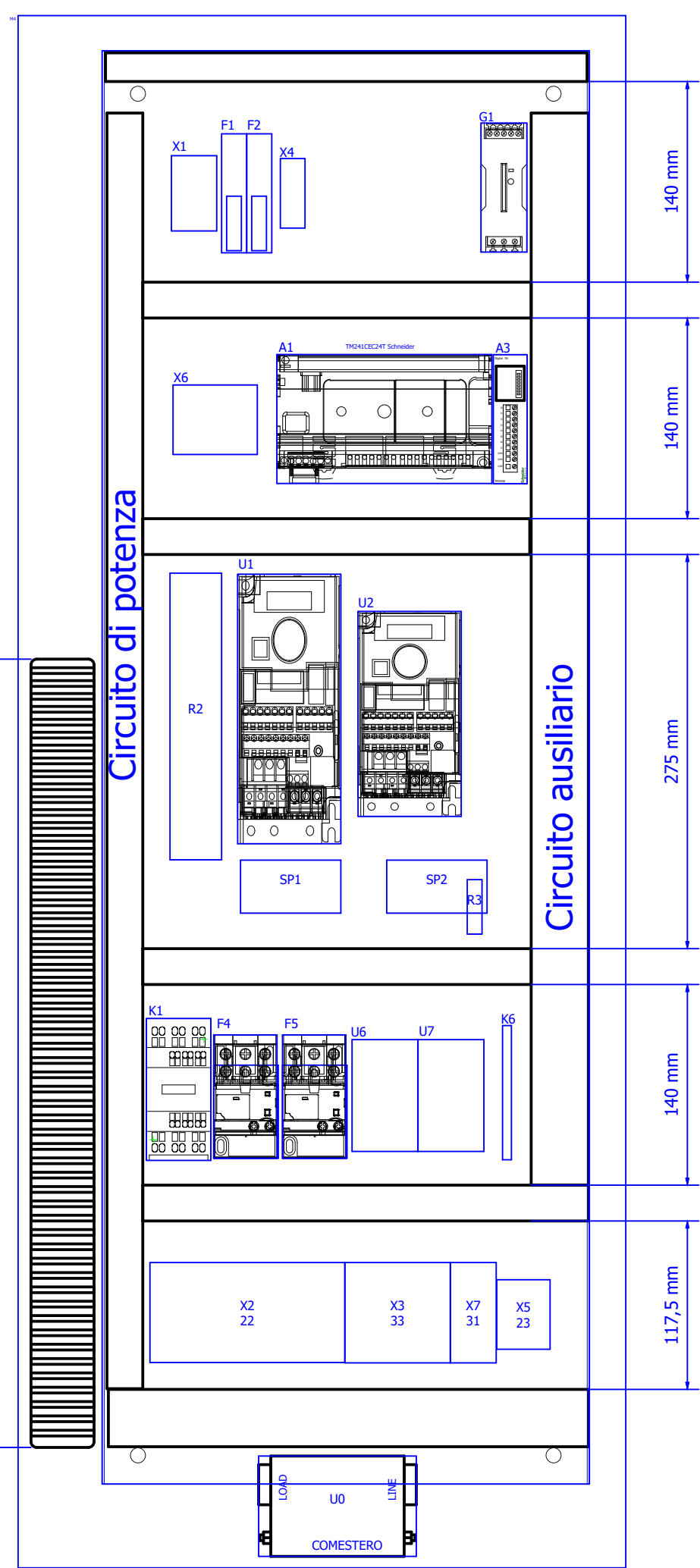
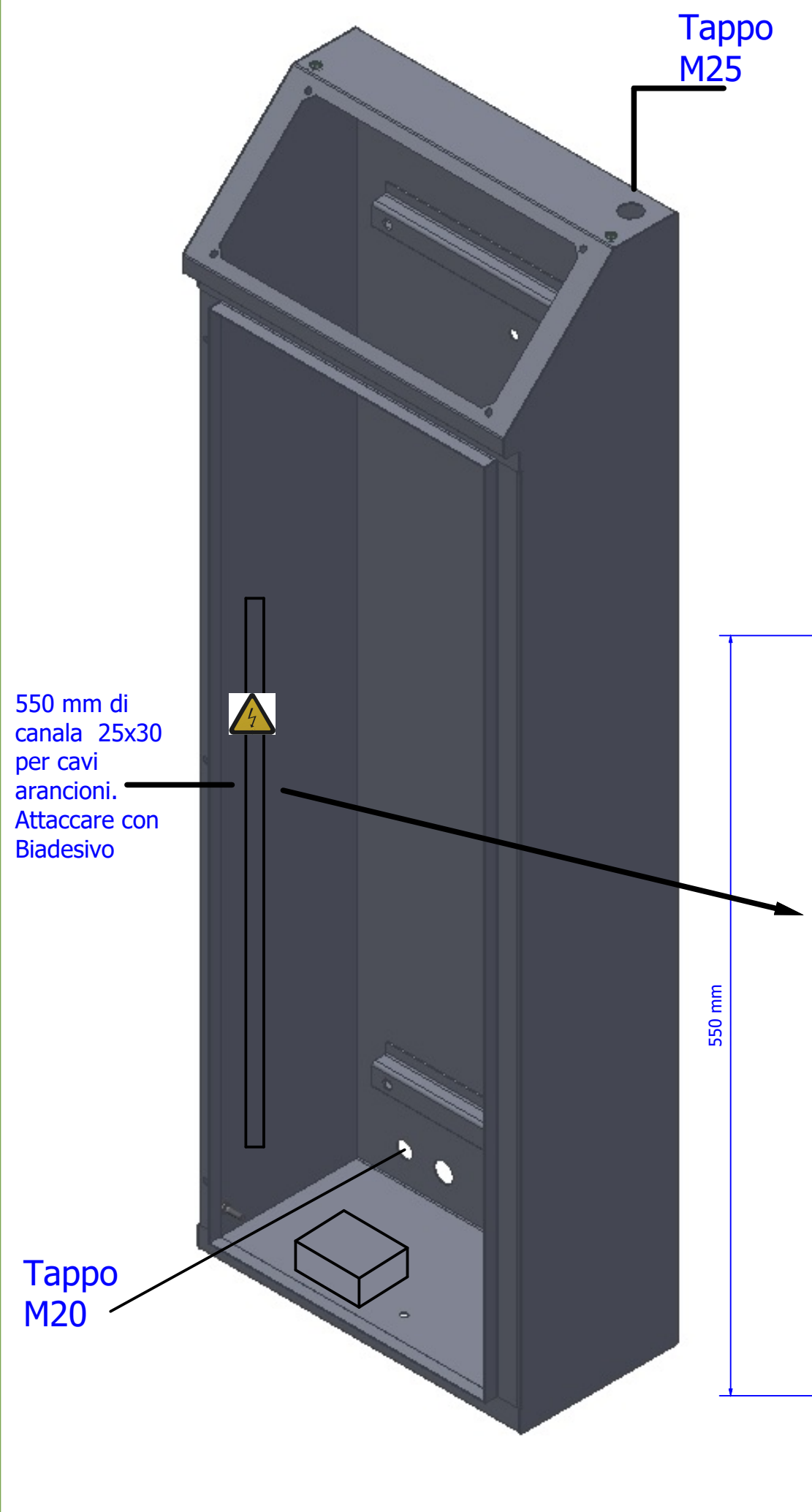

QE

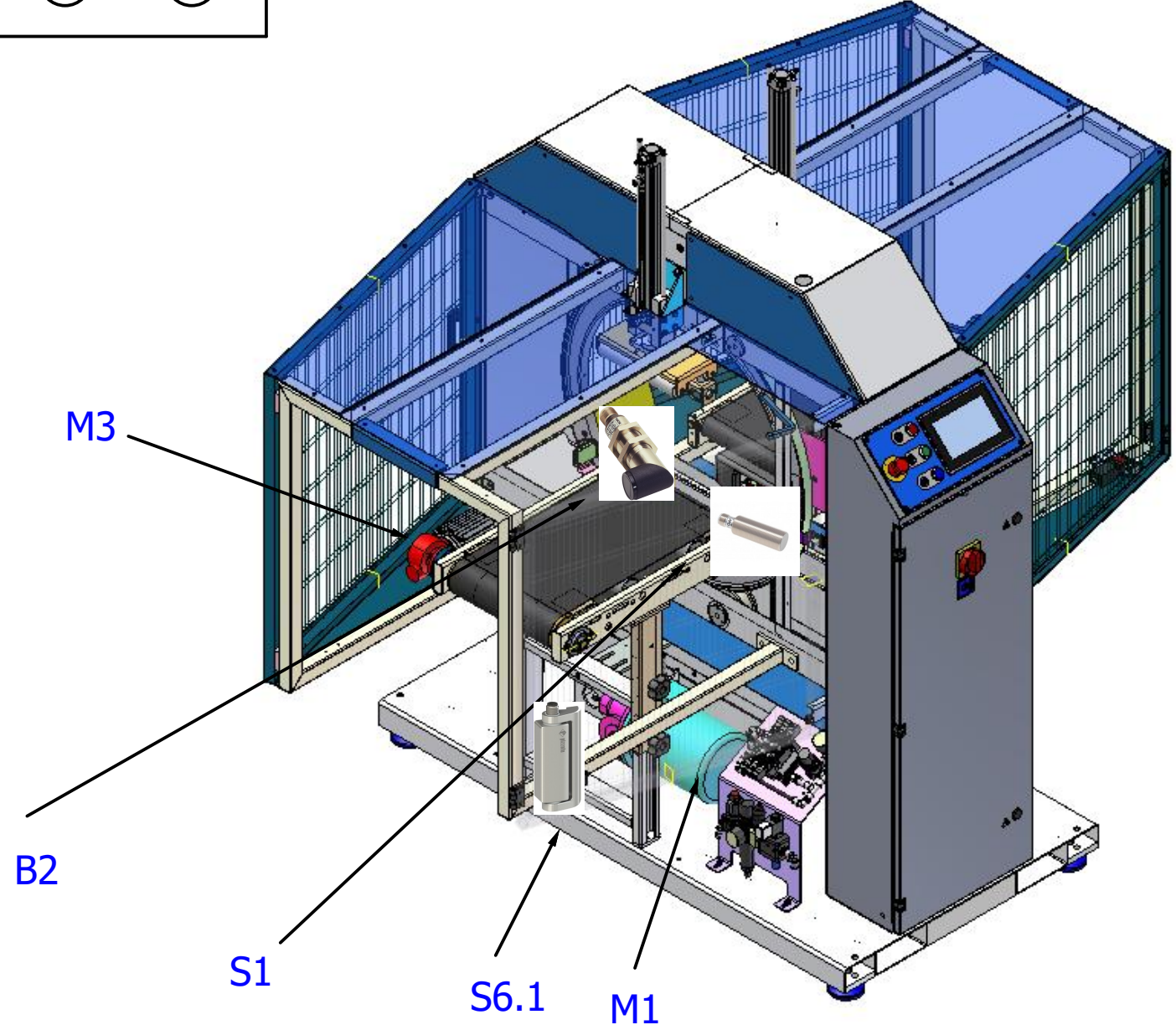
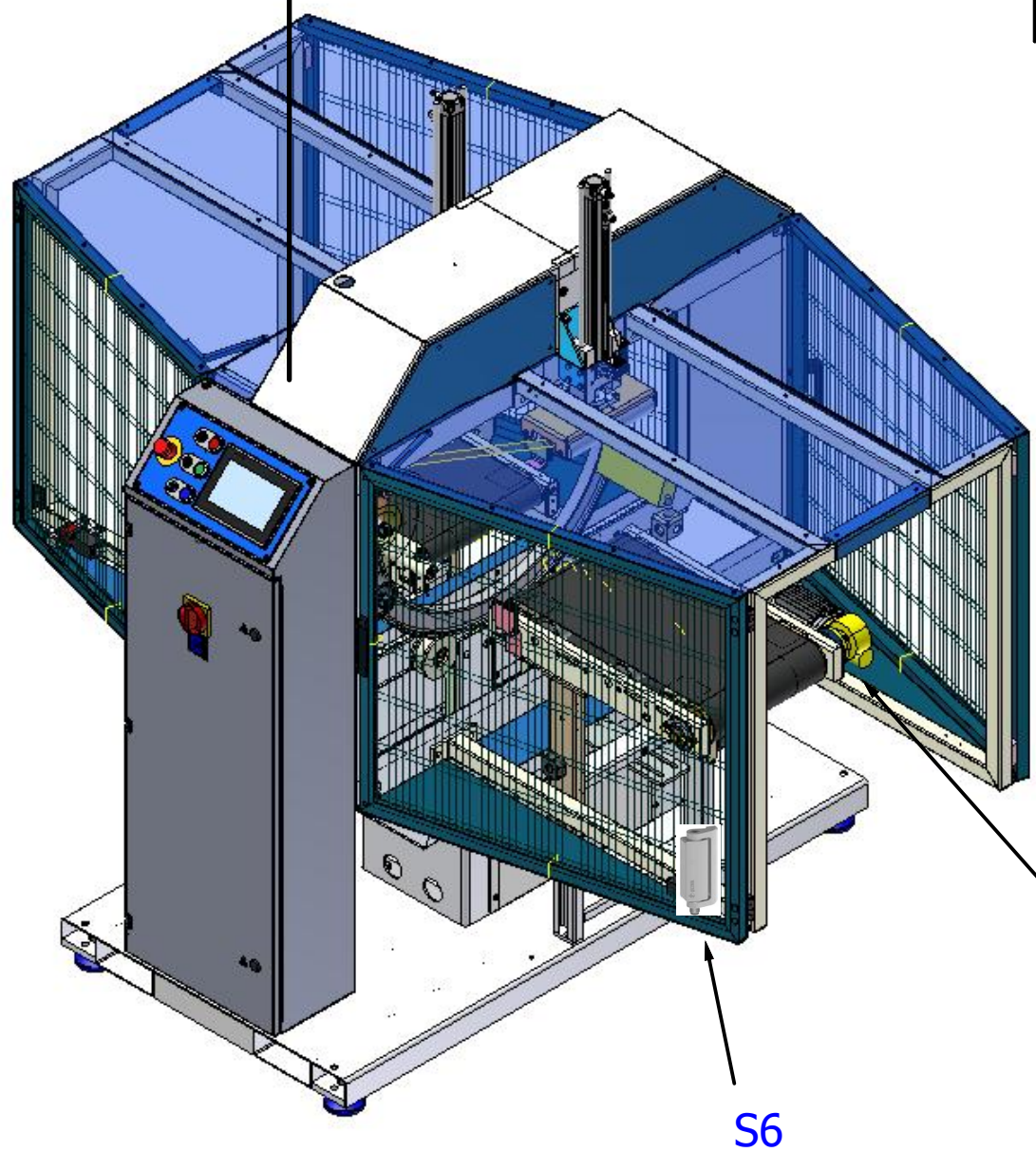
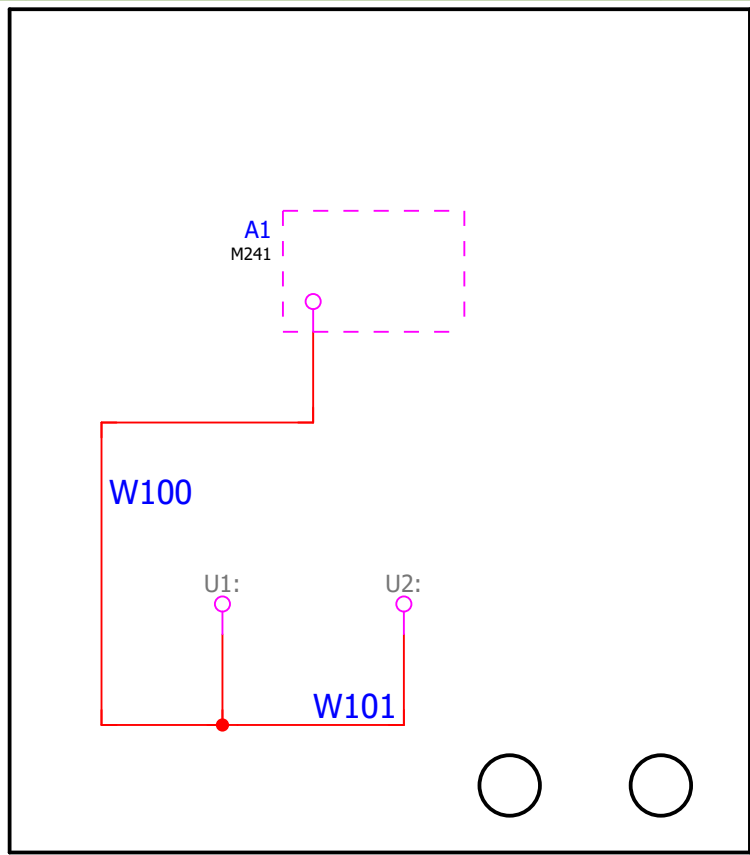

Sommario cavi Cable overview

Cavo -W1	Origine -U1;-E1	N° Conduttori	Sezione 1,5 mm ²	Capicorda Puntalino	Spelatura origine (cm)	Lunghezza fuori cassetta (m)	Spelatura destinazione (cm)	Capicorda destinazione Occhiello D=4; GNDeSCH D=5	Destinazione -M1	Note
-W3	-F4;-E4	4G	1,5 mm ²		10	2,8	10	Occhiello D=4; GNDeSCH D=5	-M2	
-W4	-F5;-E5	4G	1,5 mm ²		10	2,8	10	Occhiello D=4; GNDeSCH D=5	-M3	
-W42	-X2	4	0,5 mm ²		10	1,8	5	Puntalino	-S15	
-W200		1	4 mm ²			3		Occhiello D=4		
-W200.1		1	4 mm ²			3		Occhiello D=4		
-W200.2		1	4 mm ²			2,7		Occhiello D=4		

Schema allacciamento morsetti

Terminal-connection diagram

Destinazioni interne
Internal targets

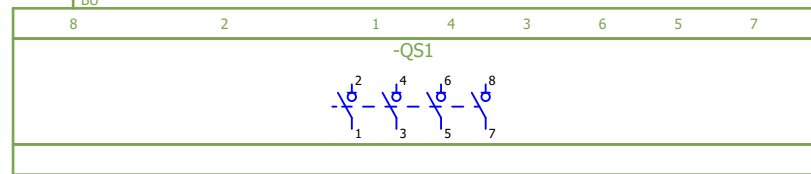
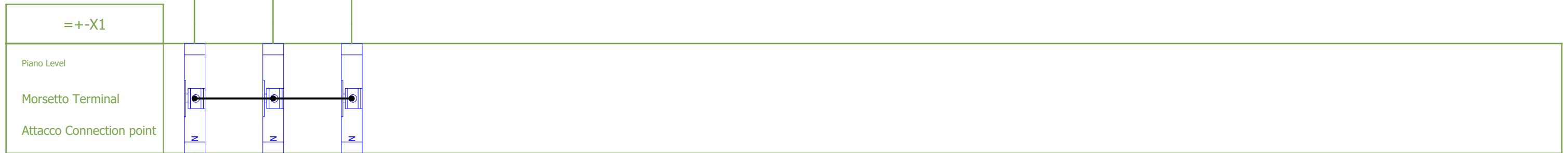
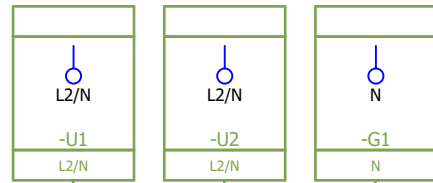

Destinazioni esterne
External targets

Schema allacciamento morsetti

Terminal-connection diagram

Destinazioni interne
Internal targets

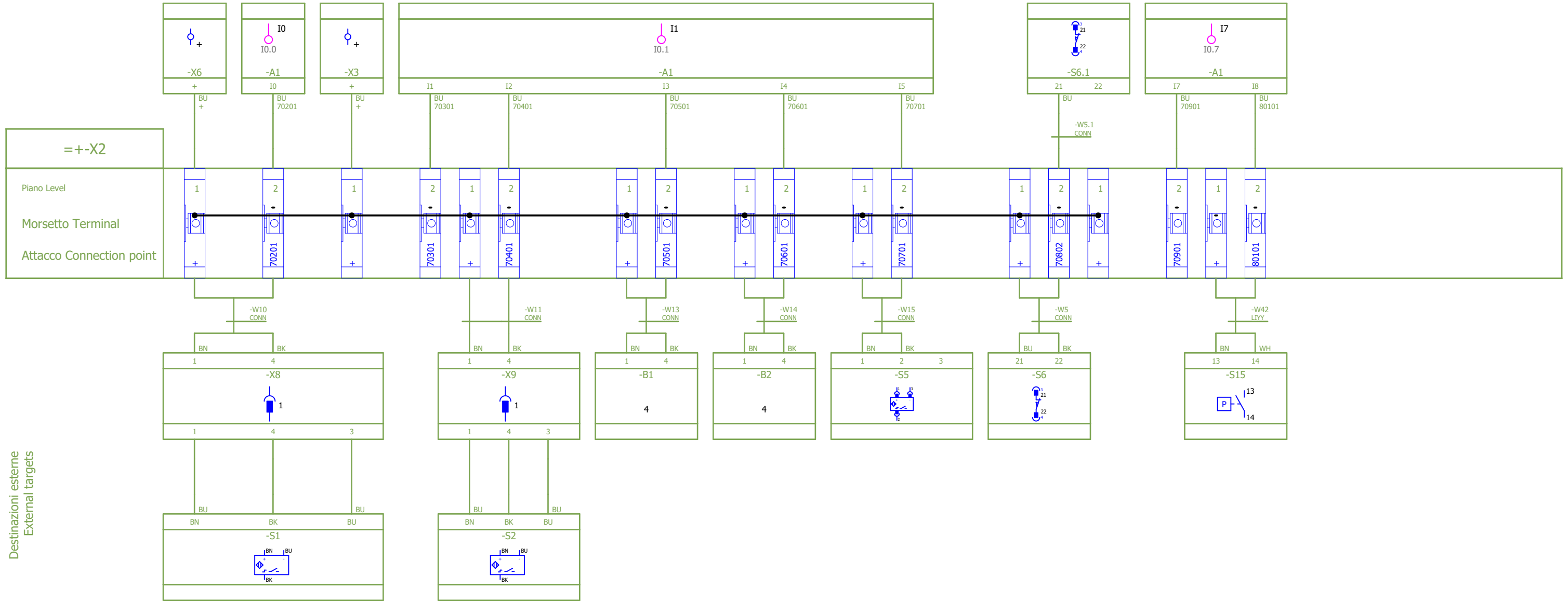

Destinazioni esterne
External targets

Schema allacciamento morsetti

Terminal-connection diagram

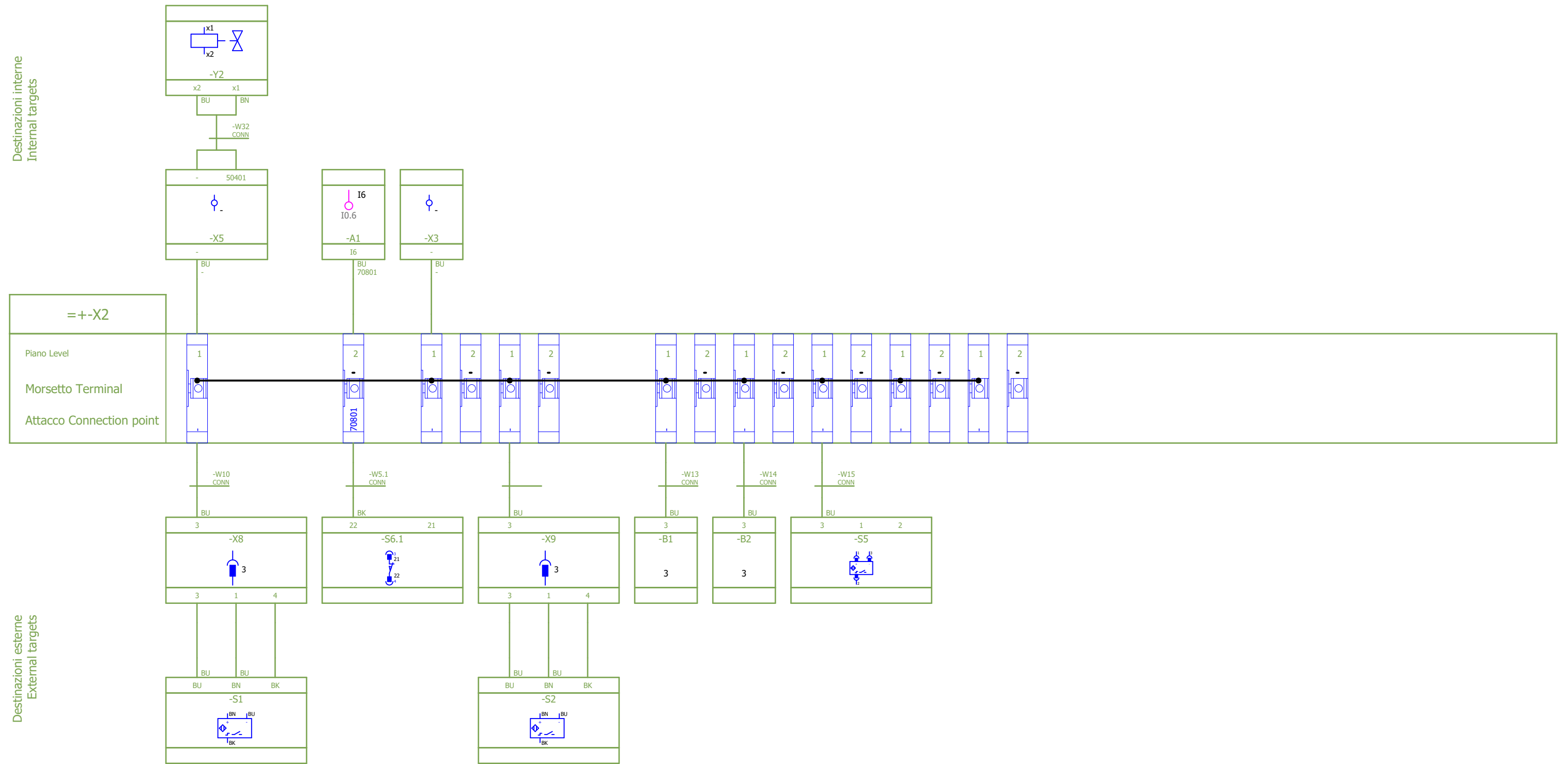

Schema allacciamento morsetti

Terminal-connection diagram

Destinazioni interne
Internal targets

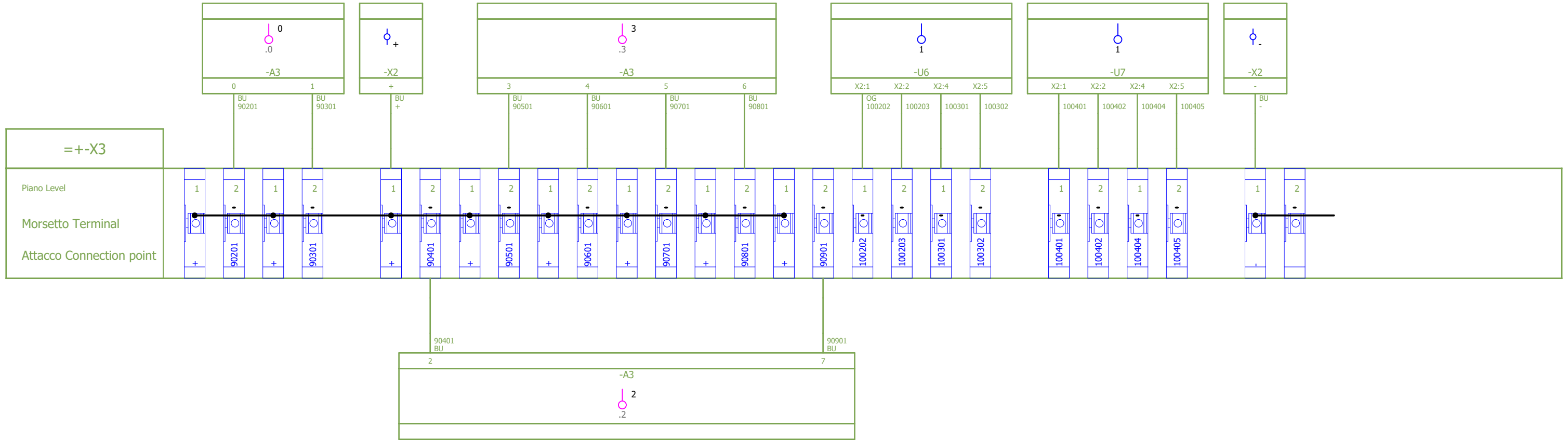

Destinazioni esterne
External targets

Alarme Pic Alarm

Schema allacciamento morsetti

Terminal-connection diagram

Destinazioni interne
Internal targets

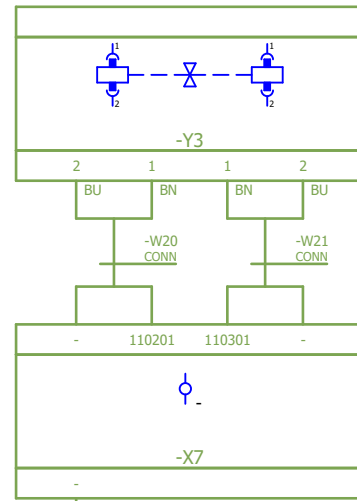

Destinazioni esterne
External targets

Schema allacciamento morsetti

Terminal-connection diagram

Destinazioni interne
Internal targets

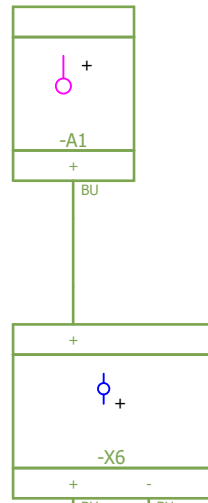

=+-X4
Piano Level
Morsetto Terminal
Attacco Connection point

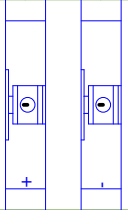

Destinazioni esterne
External targets



Description

R-Connect
R-Connect

Code	3709303472	Date	06/12/2017	Total	30	Prev	226	Subs	228	Page	227
Machine	ORBIT 4-6-9.125										

Schema allacciamento morsetti

Terminal-connection diagram

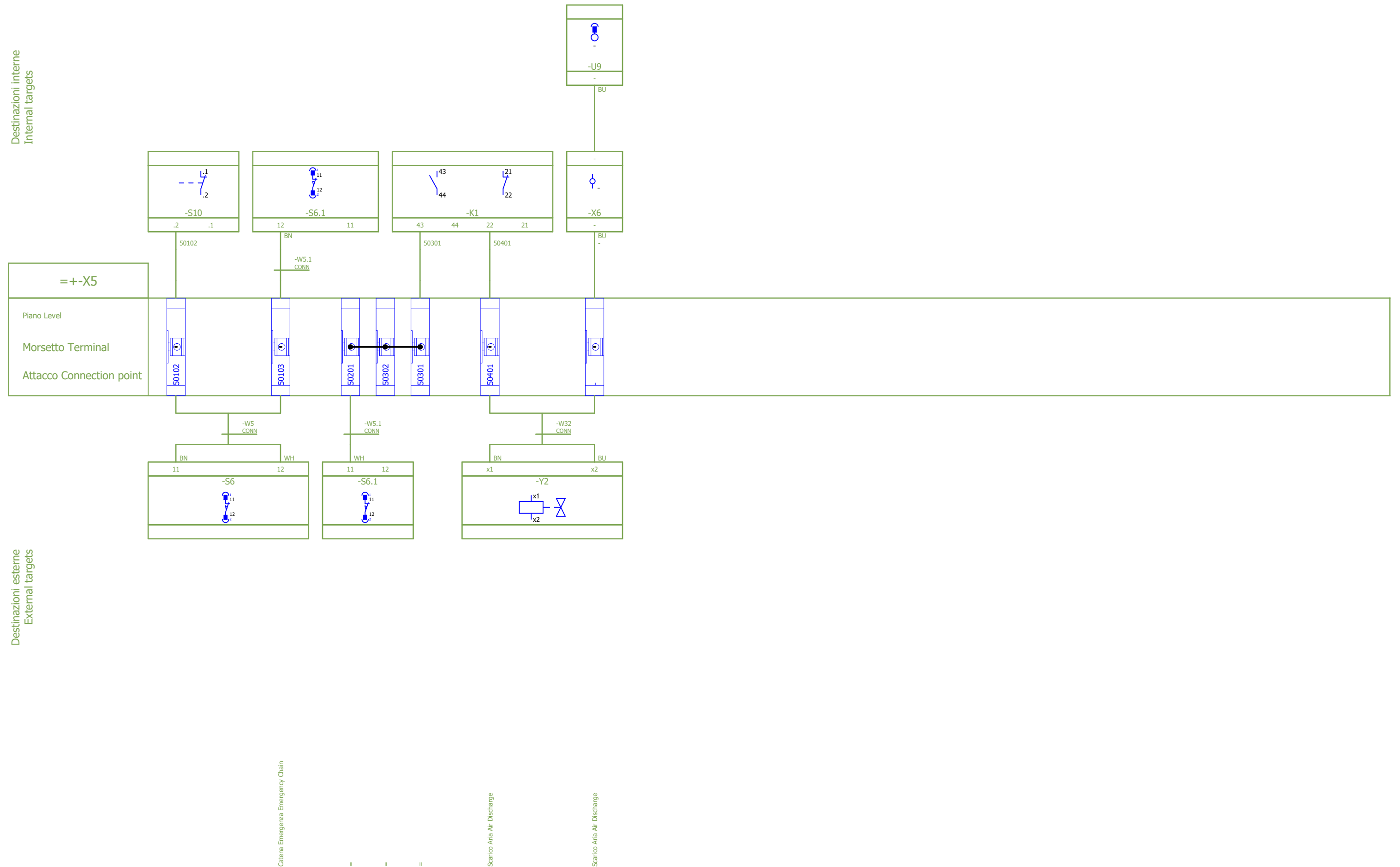

Schema allacciamento morsetti

Terminal-connection diagram

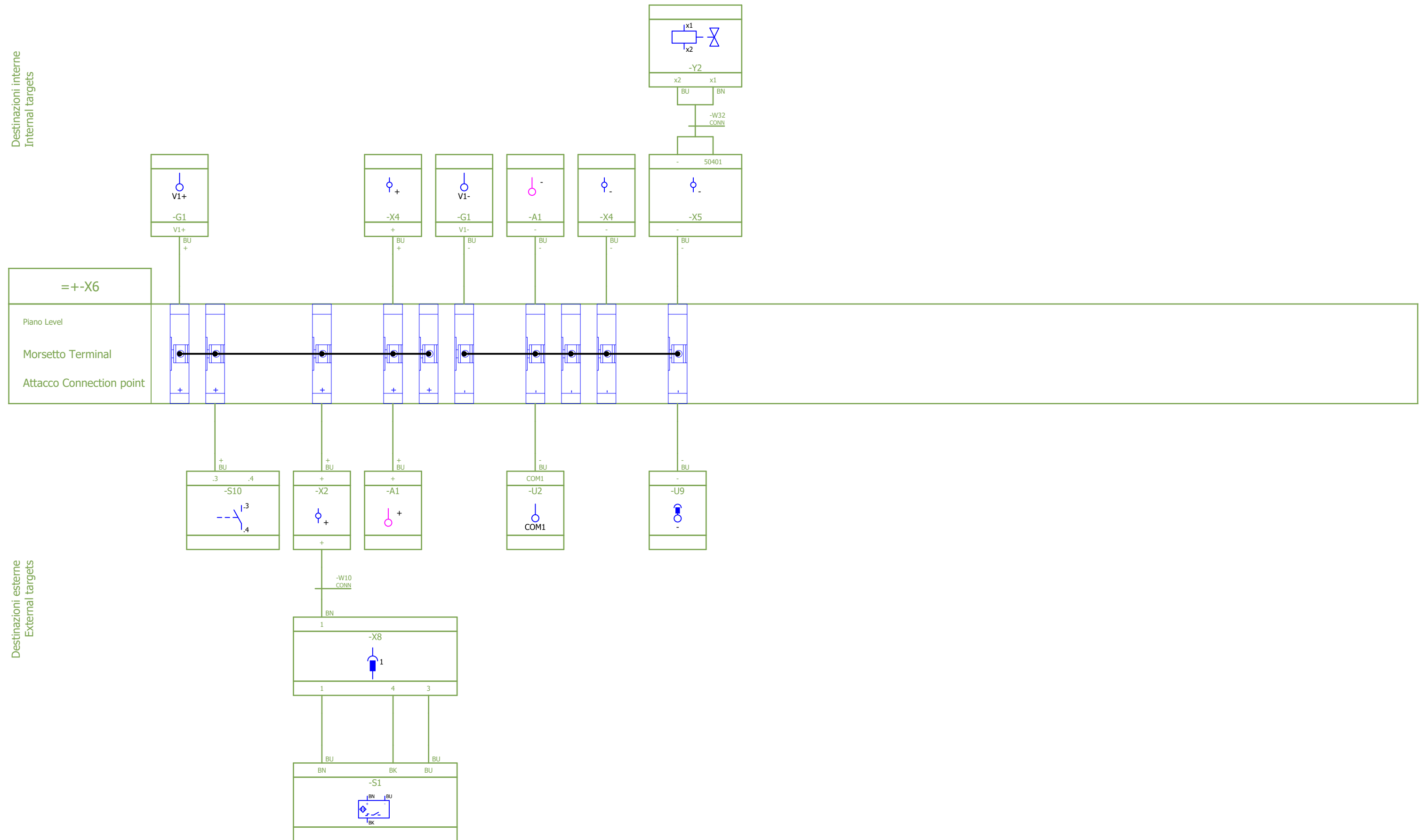

Schema allacciamento morsetti

Terminal-connection diagram

Destinazioni interne
Internal targets

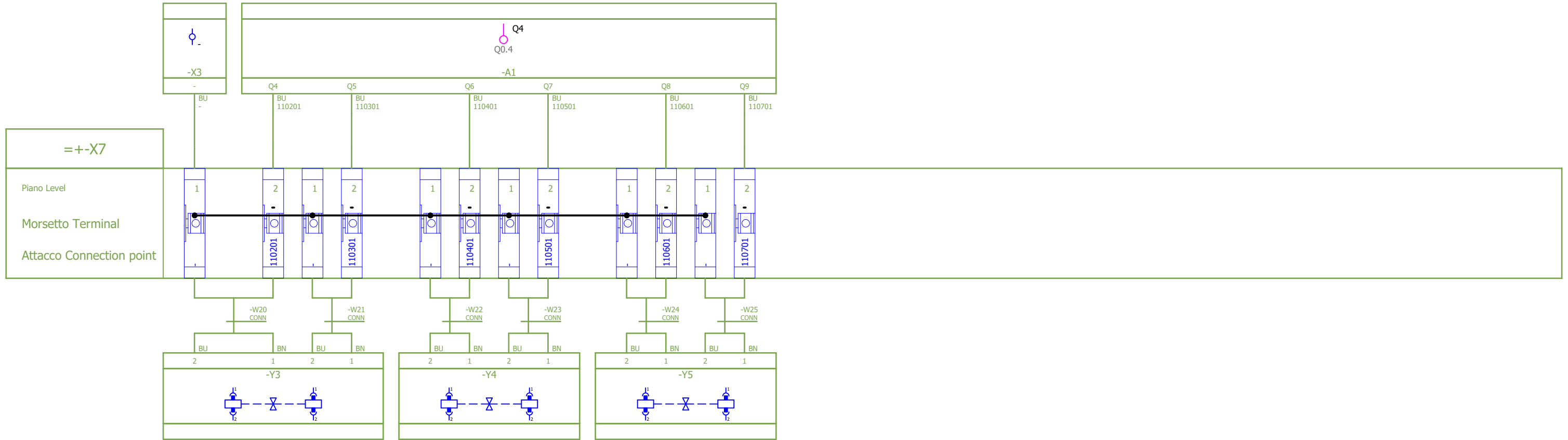

Destinazioni esterne
External targets

Pinza Chiusa Backward Clamp

Salita Pressore Ingresso Presser Rise Input

Discesa Pressore Ingresso Presser Fall Input

Discesa Pressore Uscita Presser Fall Output