



Page left blank intentionally

## INDEX

<b>1. GENERAL INFORMATION .....</b>	<b>5</b>
1.1. PURPOSE OF THE MANUAL .....	5
1.2. MANUFACTURER AND MACHINE IDENTIFICATION .....	6
1.3. TERMS AND DEFINITIONS .....	7
1.3.1. PICTOGRAMS INDICATING DANGER .....	8
1.3.2. PICTOGRAMS INDICATING PROHIBITION .....	9
1.3.3. PICTOGRAMS INDICATING OBLIGATION .....	10
1.4. HOW TO REQUEST ASSISTANCE .....	11
1.5. ATTACHED DOCUMENTATION .....	11
1.6. HOW TO READ THE INSTRUCTIONS FOR USE .....	11
<b>2. SAFETY INFORMATION.....</b>	<b>12</b>
2.1. GENERAL SAFETY WARNINGS .....	12
2.2. SAFETY WARNINGS FOR HANDLING AND INSTALLATION .....	13
2.3. SAFETY WARNINGS FOR USE AND OPERATION .....	14
2.4. SAFETY WARNINGS RELATED TO MISUSE .....	15
2.4.1. REASONABLY FORESEEABLE MISUSE .....	15
2.4.2. EMPLOYER OBLIGATIONS .....	15
2.5. SAFETY WARNINGS ON RESIDUAL RISKS .....	16
2.6. SAFETY WARNINGS FOR ADJUSTMENTS AND MAINTENANCE .....	18
2.7. SAFETY WARNING FOR THE ELECTRICAL EQUIPMENT .....	18
2.8. INFORMATION AND SAFETY SIGNS .....	19
2.9. PERIMETER AREAS .....	20
<b>3. TECHNICAL INFORMATION .....</b>	<b>21</b>
3.1. MACHINE GENERAL DESCRIPTION .....	21
3.1.1. MACHINE MODELS DESCRIPTION .....	23
3.2. DESCRIPTION OF THE OPERATION CYCLE .....	24
3.3. SAFETY DEVICE DESCRIPTION .....	26
3.4. DESCRIPTION OF ELECTRICAL DEVICES .....	27
3.5. DESCRIPTION OF PNEUMATIC DEVICES (OPTIONAL) .....	28
3.6. DESCRIPTION OF ACCESSORIES ON REQUEST .....	29
3.7. TECHNICAL SPECIFICATIONS .....	30
3.7.1. CLAMPING, CUTTING AND SEALING (OPTIONAL) .....	30
3.7.2. SPOOL FEATURES .....	30
3.7.3. PRODUCT DIMENSIONS .....	31
3.7.4. MACHINE DIMENSIONS.....	32
3.8. NOISE LEVEL .....	35
3.9. INSTALLATION ENVIRONMENT CHARACTERISTICS.....	35
<b>4. INFORMATION ON HANDLING AND INSTALLATION .....</b>	<b>36</b>
4.1. RECOMMENDATIONS FOR HANDLING AND LOADING .....	36
4.2. PACKING AND UNPACKING .....	36
4.3. TRANSPORT AND HANDLING .....	37
4.4. INSTALLATION OF THE MACHINE .....	39
4.4.1. MACHINE INSTALLATION IN COLUMN VERSION .....	39
4.4.2. WALL-MOUNTED MACHINE INSTALLATION .....	43
4.4.3. INSTALLATION OF CW AUTOMATIC CUTTING AND SEALING SYSTEM (OPTIONAL) .....	47
4.4.4. INSTALLATION OF CS AUTOMATIC CUTTING AND SPREADING SYSTEM (OPTIONAL) .....	49
4.5. RECOMMENDATIONS FOR CONNECTIONS .....	51
4.6. PNEUMATIC CONNECTION (ONLY FOR ROTOTECH).....	51
4.7. ELECTRICAL CONNECTION .....	52
<b>5. INFORMATION ON ADJUSTMENTS .....</b>	<b>53</b>
5.1. RECOMMENDATIONS FOR ADJUSTMENTS .....	53
5.2. "FILM STRETCH" ADJUSTMENT .....	54
5.2.1. SPOOL CARRIAGES OF "PDS" TYPE (PRE-STRETCH GEAR REPLACEMENT) .....	54
5.2.2. SPOOL CARRIAGES OF "FR for mesh" TYPE .....	56

5.3. CLAMP CLOSING ADJUSTMENT .....	56
5.4. SEALING/SPREADING DEVICE ADVANCE ADJUSTMENT .....	57
5.5. AIR FLOW ADJUSTMENT .....	57
<b>6. INFORMATION ABOUT THE USE .....</b>	<b>58</b>
6.1. RECOMMENDATIONS FOR OPERATION AND USE .....	58
6.2. DESCRIPTION OF THE CONTROLS .....	58
6.3. DESCRIPTION OF USER INTERFACE .....	59
6.3.1. NUMERICAL AND ALPHANUMERICAL KEYBOARD .....	62
6.3.2. PROGRAMMING WINDOW .....	63
6.4. "HOME" PAGE .....	64
6.5. "MANUAL HANDLING" PAGE .....	66
6.5.1. MANUAL REINFORCEMENT FUNCTION .....	67
6.6. "RECIPES" PAGE .....	68
6.7. "WRAPPING CYCLE" PAGE .....	69
6.8. "GENERAL PARAMETERS" PAGE .....	70
6.9. "PRODUCTION COUNTERS (PALLETS)" PAGE .....	71
6.10. "HMI SETTINGS" PAGE .....	72
6.11. "PASSWORD CHANGE" SCREEN .....	73
6.12. "ENTER PASSWORD" SCREEN (USER LOGIN) .....	74
6.13. "SERVICE" SCREEN .....	75
6.14. NEW RECIPE PROGRAMMING .....	76
6.15. MACHINE SWITCHING ON AND OFF .....	77
6.16. CYCLE PARAMETERS SETTING .....	77
6.17. DESCRIPTION OF THE WRAPPING CYCLES .....	78
6.17.1. SINGLE WRAPPING CYCLE .....	78
6.17.2. DOUBLE WRAPPING CYCLE .....	78
6.17.3. WRAPPING CYCLE WITH FEEDER .....	79
6.18. CYCLE START AND STOP .....	80
6.19. SPOOL LOADING .....	81
<b>7. MAINTENANCE INFORMATION .....</b>	<b>82</b>
7.1. RECOMMENDATIONS FOR MAINTENANCE .....	82
7.2. PERIODICAL MAINTENANCE INTERVALS .....	83
7.3. LUBRICATION POINT DIAGRAM .....	84
7.4. LUBRICANT TABLE .....	85
7.5. CONDENSATE DRAINAGE .....	87
7.6. AIR FILTER CLEANING .....	87
7.7. LIFTING BELT AND PULLEY INSPECTION .....	88
<b>8. FAULT INFORMATION .....</b>	<b>89</b>
8.1. ALARM MESSAGES .....	89
<b>9. REPLACEMENT INFORMATION .....</b>	<b>90</b>
9.1. RECOMMENDATIONS FOR REPLACING MACHINE PARTS .....	90
9.2. CUTTING WIRE REPLACEMENT (OPTIONAL) .....	91
9.3. REPLACEMENT OF CARRIAGE SLIDING GUIDE SHOE SEAL .....	92
9.4. RECOMMENDED SPARE PARTS LIST .....	93
9.5. MACHINE DECOMMISSIONING AND SCRAPPING .....	93
9.5.1. MACHINE DECOMMISSIONING .....	93
9.5.2. MACHINE SCRAPPING .....	93
<b>10. ANNEXES .....</b>	<b>94</b>
10.1. WARRANTY CONDITIONS .....	94
10.2. PNEUMATIC DIAGRAM .....	95

## 1. GENERAL INFORMATION

### 1.1. PURPOSE OF THE MANUAL

- The manual is an integral part of the machine and is aimed at providing the operator with the “Instructions for use” in order to prevent and minimise the risks that arise from human-machine interaction.  
**The information has been written by the Manufacturer in Italian (the original language) in full compliance with the professional writing principles and the regulations in force.**  
**The communication principles were chosen according to the target readers in order to ease the reading and understanding of the information.**  
**The information may be translated into other languages to satisfy the legal and/or market requirements.**  
**The manuals must be translated directly from the original instructions, without modifications.**  
**Each translation (including that provided by the purchasing agent or by the company that introduces the machine into the country in question) must specify the message “Translation of the original instructions”.**
- Refer to the table of contents in order to easily identify the subjects of interest.
- Some information may not correspond completely to the actual configuration of the machine delivered.
- Any additional information does not affect the readability of the text and the safety level.
- The Manufacturer reserves the right to modify the contents of the manual without prior notice provided that the safety level is not altered.
- Every notification by the recipients can be an important contribution to the improvement of after-sales services that the manufacturer intends to offer to its customers.
- The symbols described below are used to highlight important information or specifications.



#### **Danger - warning**

The symbol indicates critically dangerous situations that if neglected can result in serious personal safety and health hazards.



#### **Caution - warning**

The symbol indicates that appropriate action must be taken to avoid causing damage or malfunction to the machine.



#### **Important**

The symbol indicates particularly important technical and operating information that should not be neglected.

## 1.2. MANUFACTURER AND MACHINE IDENTIFICATION

The illustrated identification plate is applied directly to the machine. It contains references and indispensable operating safety indications.

1. Machine model.
2. Machine serial number.
3. Year of manufacture.
4. Power supply voltage.
5. Power supply frequency.
6. Power supply phases.
7. Absorbed electric current.
8. Installed power.
9. Air consumption.
10. Air supply max. pressure.
11. Machine weight.
12. Manufacturer's identification.
13. Name.

12



**ROBOPAC S.p.a**  
**Via Fabrizio da Montebello, 81**  
**47892 Repubblica di San Marino**  
**Phone (+378) 0549 910511**  
**Fax (+378) 0549 908549**



DENOMINAZIONE DENOMINATION	(13)	
MODELLO MODEL		(1)
MATRICOLA SERIAL NUMBER	(2)	
DATA DATE OF MAN.		(3)
ALIMENTAZIONE SUPPLY VOL.	(4)	V
FREQUENZA FREQUENCY	(5)	Hz
N.FASI PHASE	(6)	
ASSORBIMENTO ABSORPTION		(7) A
POTENZA TOT. TOTAL POWER	(8)	kw
CONSUMO ARIA AIR CONSUMPTION		(9) l/min
PRESSIONE MAX MAX. PRESSURE	(10)	bar
PESO WEIGHT		(11) kg

### 1.3. TERMS AND DEFINITIONS

Some recurring terms found within the manual are described in order to complete their meaning.



**Maintenance:**

The set of operations required to maintain the machine efficient and in good working order. Normally some operations are scheduled by the manufacturer, who defines the necessary skills and methods of intervention.

Some unscheduled operations must be performed after consulting the manufacturer.



**Operator:**

A person chosen and authorised among those who have the requirements, skills and information necessary for installation, use and ordinary maintenance of the machine.



**Maintenance technician:**

Technician chosen and authorised among those who have the requirements to perform routine and extraordinary maintenance on the machine. Therefore, the technician must have accurate information and competences with particular skills in the field of intervention.



**Format changeover:**

Set of operations to carry out on the machine before starting to work with characteristics other than the previous ones.



**Training:**

Training process aimed at transferring to the new operator the knowledge, skills and behaviours required to operate the machine autonomously, properly and safely.



**Installer:**

Technician chosen and authorised by the manufacturer or by its representative, among those with the requirements to install and test the machine or the relevant system.



**Assistant:**

Employee assigned to assist the production processes of the machine or system in question.



**Production manager:**

Qualified technician, with experience and competence in the field of machinery for the reference sector. Depending on the production requirements, the production manager can operate the machine directly, or

select the operator to be assigned to the task.

### 1.3.1. PICTOGRAMS INDICATING DANGER

The following table summarises the safety-related pictograms which indicate **DANGER**.



#### ATTENTION - GENERIC DANGER

This draws the attention of the personnel concerned to the risk of physical injuries caused by the operation described if it is not carried out in compliance with safety regulations.



#### ATTENTION - DANGER DUE TO CONTACT WITH LIVE PARTS

This indicates to the personnel concerned that the described operation poses, if not carried out in compliance with safety regulations, a risk of electric shock.



#### ATTENTION - DANGER DUE TO FLAMMABLE MATERIAL



#### ATTENTION - DANGER DUE TO MOVING PARTS



#### ATTENTION- DANGER DUE TO HIGH TEMPERATURES



#### ATTENTION - DANGER DUE TO SUSPENDED LOADS



#### ATTENTION - DANGER DUE TO CONTACT WITH OVERHEAD OBSTACLES



#### ATTENTION - TRIPPING OR FALLING DANGER



#### ATTENTION - TANGLING DANGER

It signals to the concerned personnel that the device bearing this pictogram features parts where there is the risk getting tangled when accessed.



#### ATTENTION - HAND CRUSHING DANGER



#### ATTENTION - SHEARING DANGER



#### ATTENTION - CUTTING DANGER

It signals to the concerned personnel that the device on which the pictogram is located has sharp parts that may injure their hands.



#### ATTENTION - DANGER DUE TO CARRIAGE MOVEMENT



#### ATTENTION - EXPLOSION DANGER

### 1.3.2. PICTOGRAMS INDICATING PROHIBITION

The following table summarises the safety-related pictograms indicating **PROHIBITION**.



#### GENERIC PROHIBITION



#### NO SMOKING

Smoking is not allowed in the area where this sign is located.



#### NO NAKED FLAMES

This symbol prohibits the use of naked flames near the machine or parts of it to prevent a fire hazard.



#### NO PEDESTRIANS

Pedestrians are not allowed to pass through the area where this signal is located.



#### DO NOT EXTINGUISH WITH WATER

Any fire that may occur near the machine or parts of it must **NOT** be extinguished with jets of water.



#### DO NOT INSERT YOUR HANDS



#### DO NOT PUSH



#### DO NOT SEAT DOWN



#### DO NOT CLIMB ONTO THE SURFACE



#### DO NOT REMOVE THE OPERATOR GUARDS

### 1.3.3. PICTOGRAMS INDICATING OBLIGATION

The following table summarises the safety-related pictograms indicating **OBLIGATION**.



#### **GENERIC OBLIGATION**

The presence of the symbol next to the description indicates the obligation to carry out the operation/manoeuvre as described and in compliance with current safety regulations, in order to avoid risks and/or injuries.



#### **OBLIGATION TO REFER TO THE OPERATOR'S MANUAL**

Obligation, before carrying out any operation on the machine, to read the Instruction Manual supplied with the machine.



#### **OBLIGATION TO USE LUBRICANTS RECOMMENDED**

Obligation, before changing the oil or the lubricants, to read the Instruction Manual supplied with the machine.



#### **OBLIGATION TO WEAR PROTECTIVE GLOVES**

The presence of the symbol next to the description requires the use of protective gloves by the operator, since the risk of injury is implicit.



#### **OBLIGATION TO WEAR PROTECTIVE GOGGLES**

The presence of the symbol next to the description requires the use of safety goggles by the operator, since the risk of injury is implicit.



#### **OBLIGATION TO WEAR A PROTECTIVE HELMET**

The presence of the symbol next to the description requires the use of a protective helmet by the operator since the risk of injury is implicit.



#### **OBLIGATION TO WEAR A PROTECTIVE MASK**

The presence of the symbol next to the description requires the use of a respiratory protective mask by the operator, since the risk of injury is implicit.



#### **OBLIGATION TO WEAR SAFETY SHOES**

The presence of the symbol next to the description requires the use of protective shoes by the operator, since the risk of injury is implicit.



#### **OBLIGATION TO WEAR PROTECTIVE CLOTHING**

The presence of the symbol next to the description requires the use of a protective overall by the operator, since the risk of injury is implicit.



#### **OBLIGATION TO WEAR EARMUFFS FOR PROTECTION AGAINST NOISE**

The presence of the symbol next to the description requires the use of earmuffs by the operator as the risk of injury is implicit.

## 1.4. HOW TO REQUEST ASSISTANCE

**Robopac** distribution network is at your disposal for any problem regarding technical assistance, spare parts and any new requirement you might need for your business.

For every technical service request regarding the machine, please indicate the data found on the identification plate, the approximate hours of use and the type of fault detected.

Please refer to one of the authorised service centres or directly to the address indicated for any need.

ROBOPAC S.p.A  
VIA FABRIZIO DA MONTEBELLO, 81  
47892 GUALDICCILO REPUBLIC OF S. MARINO (RSM)  
Tel. 0549 (international ++378) 910511  
Fax 0549/908549 - 905946  
<http://www.robopac.com>

## 1.5. ATTACHED DOCUMENTATION

The machine is provided with the documentation listed below, unless otherwise agreed.

- EC DECLARATION OF CONFORMITY.
- Warranty conditions.
- Pneumatic diagram.
- Wiring diagram and list of components.
- Manuals of installed commercial devices (if necessary for machine use).
- Unpacking and installation instructions.
- Quick guide for quick start.
- USB pendrive containing the information listed below.
  - Use and maintenance manual translated into various languages.
  - Spare parts catalogue.
  - Machine programming software.
  - Wiring Diagrams.

## 1.6. HOW TO READ THE INSTRUCTIONS FOR USE

The manual is divided into chapters, each of which describes a specific category of information.



### Important

**Every operator who interacts with the machine, in addition to reading all the documentation, must read and learn the information that falls within his/her operational competence.**

Refer to the abbreviation that precedes the title of the chapters in the index, to search for topics to consult.

These instructions are the result of an automatic system that assembles text and illustrations, so it is possible that when changing pages, there might be interruptions in the flow of text and tables.



### Important

**Keep this manual for the entire duration of the machine useful life in a well known and easy to access place, available for reference any time the need should arise.**

## 2. SAFETY INFORMATION

### 2.1. GENERAL SAFETY WARNINGS



**Caution - warning**

Carefully read the “Instructions for use” specified in the manual and those applied directly to the machine.

It is important to dedicate a little time to read the “Instructions for use” in order to minimise the risks and avoid unpleasant accidents.

Before performing any operation, the operator must make sure that he/she has understood the “instructions for use”.



**Danger - warning**

Pay attention to the safety warnings, do not misuse the machine and assess the possible residual risks.

Caution is essential.

Safety is also in the hands of those who interface with the machine throughout its life span.



**Important**

Sometimes, accidents can be caused by a “careless” use of the machine by the operator.

Usually it is too late to remember what should have been done when the accident has already happened.



**Caution - warning**

Preserve the readability of the information signs and observe the indications given.

The information signs may have different shapes and colours, indicating hazards, obligations, prohibitions and indications.

Tampering with the safety devices and the removal of the same may create risks (even severe) for the operators.

The personnel authorised to carry out any operation with the machine must have acknowledged experiences in the specific field.



**Important**

The manufacturer is not responsible for any damage to the packaged product occurred during wrapping, stabilisation and following operations.



**Important**

Non-compliance with the instructions given may cause risks to the safety and health of people, as well as economic damages.

## 2.2. SAFETY WARNINGS FOR HANDLING AND INSTALLATION



### Danger - warning

The personnel authorised to handle the machine (load and unload) must possess the necessary technical and professional knowledge and skills.

Handle (load and unload) the machine according to the instructions affixed directly to the machine, to the package and in the user manual.

During handling use one or more assistants, if required. This may pose unexpected risks.

In order to minimise the risks related to assistants' involvement, you must inform them in advance on the type of work to be carried out and the behaviour to adopt.

Handling must be carried out with the aid of specific means (crane, forklift truck etc.) by qualified personnel capable of observing the safety requirements.

When using the lifting means, insert and/or fasten the devices (hooks, forks etc.) only into the points provided on the package and/or on the machine.

Transport the machine with suitable means of adequate capacity.

The minimum and maximum temperature (during transport and/or storage) must fall within the range allowed in order to prevent damaging the electrical components.

Install the machine only in spaces with no explosion and/or fire risks.

Avoid spaces exposed to atmospheric and corrosive agents.

Assess, prior to installation, if it is necessary to implement a "safety plan" in order to protect the safety of the personnel involved.

Provide proper safety conditions when operating in high areas that are dangerous or hard to access.

Install the machine according to the minimum perimeter spaces indicated by the Manufacturer and the surrounding working activities.

Prepare a machine installation project if the machine is to interact (directly or indirectly) with another machine or with a production line.

The project must take into account all operating conditions, in order to comply with all laws in force on matter of safety in the workplace.

Check that the installation space is properly ventilated in order to avoid unhealthy air concentration for the operators.

Implement the most suitable solutions to minimise noise emission levels and acoustic pollution.

Carry out the electrical connections in accordance with the best practice and in full compliance with the instructions provided by the Manufacturer and the specific regulations in force.



### Important

**The machine is designed to be connected to a TN-S infeed system and the impedance value of the PE circuit, to which the machine is connected, must be below 400 mΩ.**

**The electrical connections must be carried out exclusively by operators with acquired and acknowledged skills in the field of intervention.**

The installer must test the machine and check, through a general test, that the machine can be commissioned without any risk for the operator.

Dispose of all the packaging components in compliance with the standards in force in the Country of installation.

**Non-compliance with the instructions given may cause risks to the safety and health of people, as well as economic damages.**

## 2.3. SAFETY WARNINGS FOR USE AND OPERATION



### Danger - warning

The operator must be trained and possess the adequate skills required to carry out the specific tasks and must be fit to use the machine safely.

When using the machine for the first time, the operator must read the manual and identify the control functions and simulate some operations, especially machine start and stop.

The machine has been designed and manufactured to meet all the operating conditions indicated by the Manufacturer.



### Caution - warning

Use the machine only with the original safety devices installed by the Manufacturer.  
Do not tamper with, disable, remove or bypass the safety devices installed on the machine.



### Danger - warning

Do not modify the constructive and functional characteristics of the machine in any way.

Do not use the machine with the safety devices not properly installed and efficient.

Always wear the Personal Protective Equipment indicated in the “Instructions for use”, **in particular safety shoes**, and that provided for by the laws in force on matter of safety in the workplace.

Always keep the perimeter areas in suitable conditions and free from obstacles in order to minimise the risks for the operator, especially near the control station.

The machine must be used **by one operator only**, that must be appointed and authorised by the employer.

The involvement of one or more assistants when performing some operations or maintenance (ordinary) interventions may pose unpredictable risks.

In order to minimise the risks related to assistants’ involvement, you must inform them in advance on the type of work to be carried out and the behaviour to adopt.

Make sure that no unauthorised persons are within the machine operating area during its production activity and during maintenance.

It is forbidden to climb onto the rotary table with forklift trucks. In addition to being dangerous, it can also damage the machine.



### Important

**Non-compliance with the instructions given may cause risks to the safety and health of people, as well as economic damages.**

## 2.4. SAFETY WARNINGS RELATED TO MISUSE

### 2.4.1. REASONABLY FORESEEABLE MISUSE

- The reasonably foreseeable misuse is: “the use of the machine in a way other than that indicated in the manual, that may stem from the easily predictable human behaviour”.  
**The machine must be used only for wrapping and stabilising products with regular shape or with a shape that ensures a stable wrapping.**  
**Packages containing liquids or insubstantial materials must have characteristics suitable to the product and be perfectly closed and sealed to prevent the contents from flowing out.**  
 Do not palletize or wrap products housed in irregularly shaped packages (boxes, liquid containers, etc.) or packages that do not guarantee their stability.
- The machine should only be used for the uses intended by the Manufacturer.
- Do not allow the machine to be used by operators that are not properly trained, informed and authorised.
- Packages containing liquid or insubstantial products must ensure that they do not leak out.
- Do not wrap bulk products of irregular shape and improperly collected to avoid an unsuitable palletization.
- Do not use the machine to wrap and stabilise living beings (animals and persons).
- Do not use the machine with wrapping material other than that provided by the Manufacturer.
- Do not use the machine as a lifting device or as a work surface (e.g. workbench).
- Do not stretch or pre-stretch the film excessively and do not wrap the product with too many wrappings in order to prevent damaging the packages and the products contained in them.
- Do not use or let the machine be used for purposes or in ways other than those intended by the Manufacturer.
- Do not use or let the machine be used with defective, deactivated and/or incorrectly installed safety devices.
- Do not continue to use the machine if malfunctions have been detected.
- Stop the machine immediately and restart it only after the normal conditions of use have been restored.
- Never carry out an intervention with the machine in operation, but only after stopping it properly, under safety conditions.
- Never use the machine without wearing the Personal Protective Equipment indicated by the Manufacturer and provided for by the laws in force on workplaces.
- Never use the machine if the scheduled maintenance interventions have not been carried out.
- Do not clean or wash the machine with aggressive products to avoid damaging the components.
- Do not replace the components with non-original spare parts or part with different design and construction features.
- Do not leave the machine unattended at the end of the production activity without shutting it down first in safety conditions.

### 2.4.2. EMPLOYER OBLIGATIONS

- The operator must be trained to acquire the required skills in the field of packaging machines or equivalent. Upon completing the training, ensure that the operator has understood the entire content of the operating manual, in particular the safety information.
- The operator must have the required skills and must be fit for the activities to be carried out in safety conditions.
- The employer must inform the operator on the reasonably foreseeable misuses and on the persistent residual risks.
- The operator must be capable of reading and understanding the user manual and must easily identify the safety signs.
- Allow the machine to be used only by operators that are properly trained, informed and authorised.



**Important**

**The employer must document the training carried out for the operators.**

## 2.5. SAFETY WARNINGS ON RESIDUAL RISKS



### Danger - warning

During design and manufacturing, the Manufacturer has paid particular attention to the residual risks that may affect the safety and health of the operators.

The residual risks are: "all the risks that persists although all safety solutions have been applied and integrated during machine design".

The list specifies the residual risks specific for this type of machine.



### Risk of shearing upper limbs:

Do not insert your hands inside moving parts.

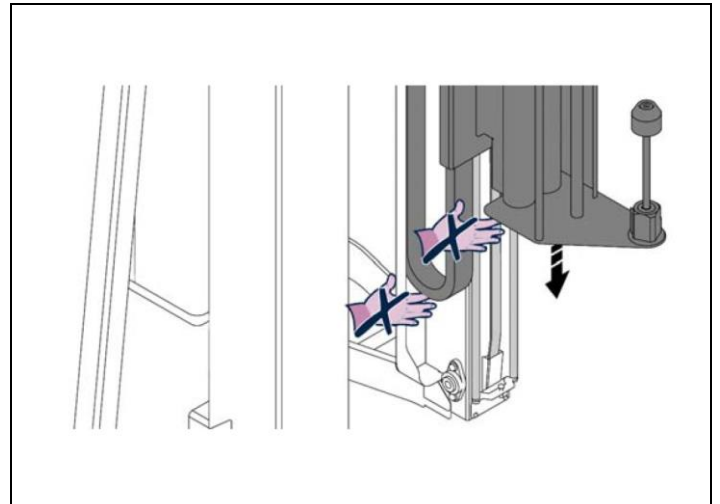

### Risk of crushing upper limbs:

Do not insert your hands inside the clamp unit (optional).

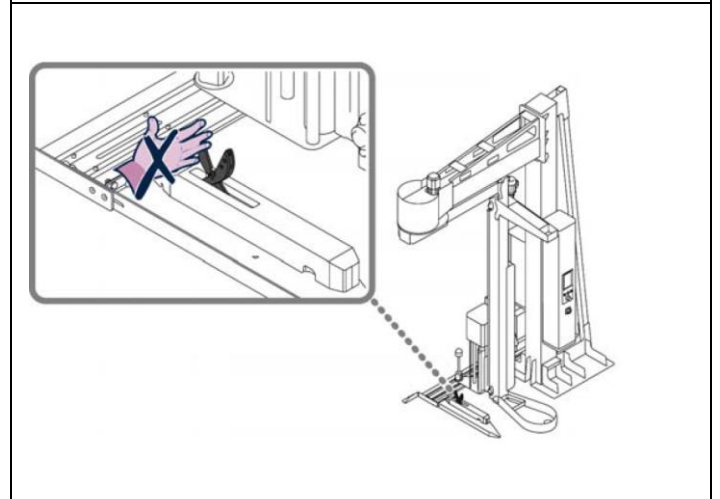



**Risk of falling or ejected objects:**

Do not use the machine at a speed which is not suitable for the type of product to be wrapped.



If the packages to be wrapped contain unstable and dangerous elements, it is necessary to implement appropriate safety measures (e.g.: perimeter protections) to avoid risks of injuries to persons.

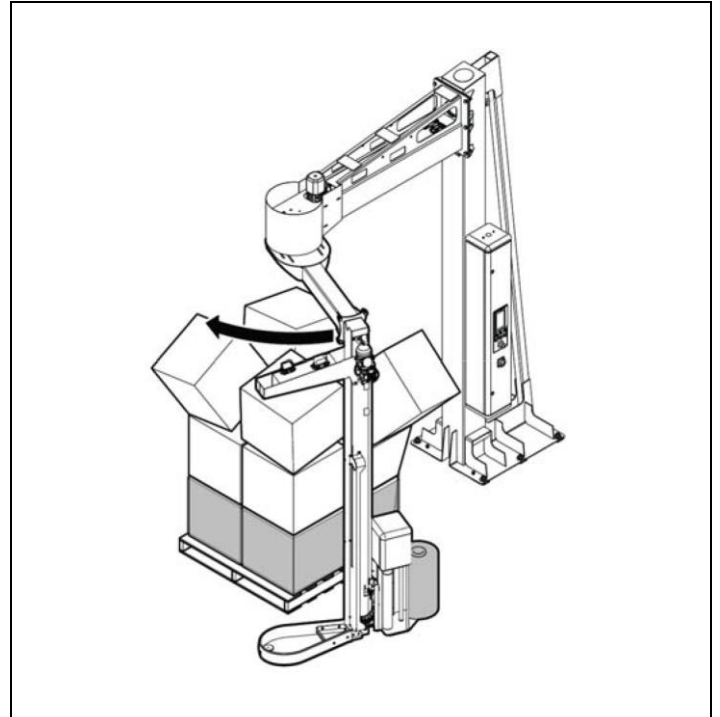

**Risk of burning/scalding:**

Never place any part of the body near the arm unit and especially the cutting wire or the sealing devices (Optional).

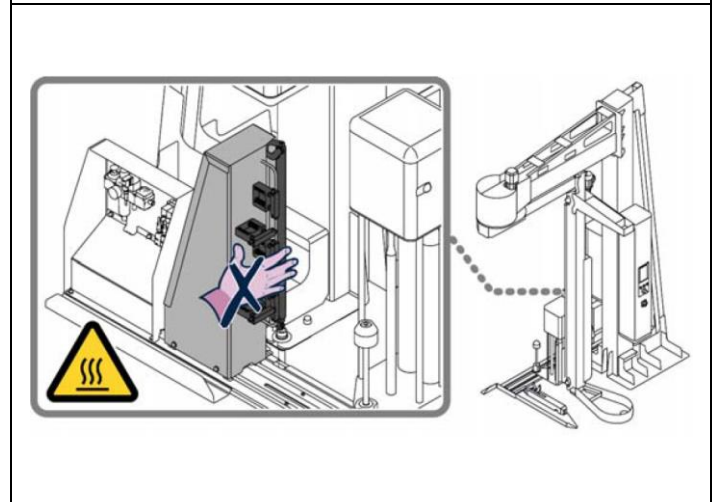

## 2.6. SAFETY WARNINGS FOR ADJUSTMENTS AND MAINTENANCE

- Keep the machine in maximum efficiency conditions and perform all the scheduled maintenance operations provided for by the Manufacturer.  
Proper maintenance will provide the best performance, a longer life span and constant compliance with safety requirements.
- Enable all machine safety devices before performing any maintenance and adjustment operations.
- Demarcate the surrounding areas and put in place adequate safety measures, as provided for by the standards on workplace safety, in order to prevent and minimise the risks.
- Maintenance interventions in areas that are not easily accessible or dangerous must be carried out after having ensured the necessary conditions are met.
- The personnel authorised to carry out the ordinary maintenance (adjustments, replacements etc.) must possess the necessary technical and professional knowledge and skills.
- Do not carry out interventions other than those indicated in the user manual without the express authorisation of the Manufacturer.
- Do not use products that contain corrosive and flammable substances or that are harmful to people's health.
- Wear Personal Protective Equipment as required by labour laws and as indicated in the "Instructions for Use" and/or on the machine.
- The use of similar but non-original spare parts may result in improper repairs, altered performance and economic damage.
- Use lubricants (oils or grease) recommended by the Manufacturer or with similar chemical-physical features.
- Do not dispose of polluting liquids, worn parts and maintenance waste into the environment.
- Select the components according to the chemical and physical features of the material and dispose of them separately in accordance with the applicable laws.
- All the extraordinary maintenance interventions shall be carried out only by authorised personnel with experience and expertise in the field of intervention.



### Important

**Non-compliance with the instructions given may cause risks to the safety and health of people, as well as economic damages.**

## 2.7. SAFETY WARNING FOR THE ELECTRICAL EQUIPMENT

The electrical equipment has been designed and manufactured in accordance with the relevant standards.

These standards consider operating conditions based on the surrounding environment.

The list contains the conditions necessary for the correct operation of the electrical equipment.

- Ambient temperature must be within **0°C** and **40°C**.
- The relative humidity should be between **50%** (measured at **40°C**) and **90%** (measured at **20°C**).
- The installation environment must be immune to and must not be a source of electromagnetic interference or radiation (x-rays, lasers, etc.).
- The environment must not have areas with concentrations of gas and dust that are potentially explosive and/or with a fire risk.
- The products and materials used during production and maintenance must not contain contaminants or corrosive agents (acids, chemicals, salts, etc.) and must not be able to penetrate and/or come into contact with electrical components.
- During transport and storage, the ambient temperature must be between **-25°C** and **55°C**.
- The electrical equipment may still be exposed to a temperature of up to **70°C** provided that the exposure time does not exceed **24** hours.
- The electrical equipment operates correctly up to **1000 m** above sea level.



### Important

**If it is not possible to comply with one or more of the conditions listed, which are essential for the correct operation of the electrical equipment, it is necessary to agree at the contractual stage which additional solutions to adopt in order to create the most suitable conditions (e.g. specific electrical components, air conditioning equipment, etc.).**

## 2.8. INFORMATION AND SAFETY SIGNS

The figure indicates the position of the safety and information signs affixed to the machine. For each sign the relative description is specified.

1. **Information sign**  
It indicates the lifting points with fork device.
2. **Electrical hazard sign**  
Do not access the area to avoid risks of electric shock or electrocution.
3. **Danger sign**  
Risk of crushing upper limbs.
4. **Danger sign**  
Risk of high temperature.
5. **Prohibition sign**  
Do not act on the component with your hands.
6. **Information sign**  
It indicates the lifting points with hook device.
7. **Information sign**  
It identifies the electric cut-out.
8. **Information sign**  
It identifies the pneumatic cut-out.
9. **Information sign**  
Machine Stop symbol.
10. **Information sign**  
Machine Start symbol.
11. **Information sign**  
Machine Reset symbol.
12. **Information sign**  
It indicates the tightening torque to be applied to screws.
13. **Obligation sign**  
It indicates the obligation, before using the machine, to read all the parts of the documentation.
14. **Information sign**  
Film unwinding symbol.
15. **Information sign**  
It indicates how to position the sealing device depending on the pallet size.



### Important

Make sure that the nameplates are clearly legible. If not, replace and reposition them at the original position.

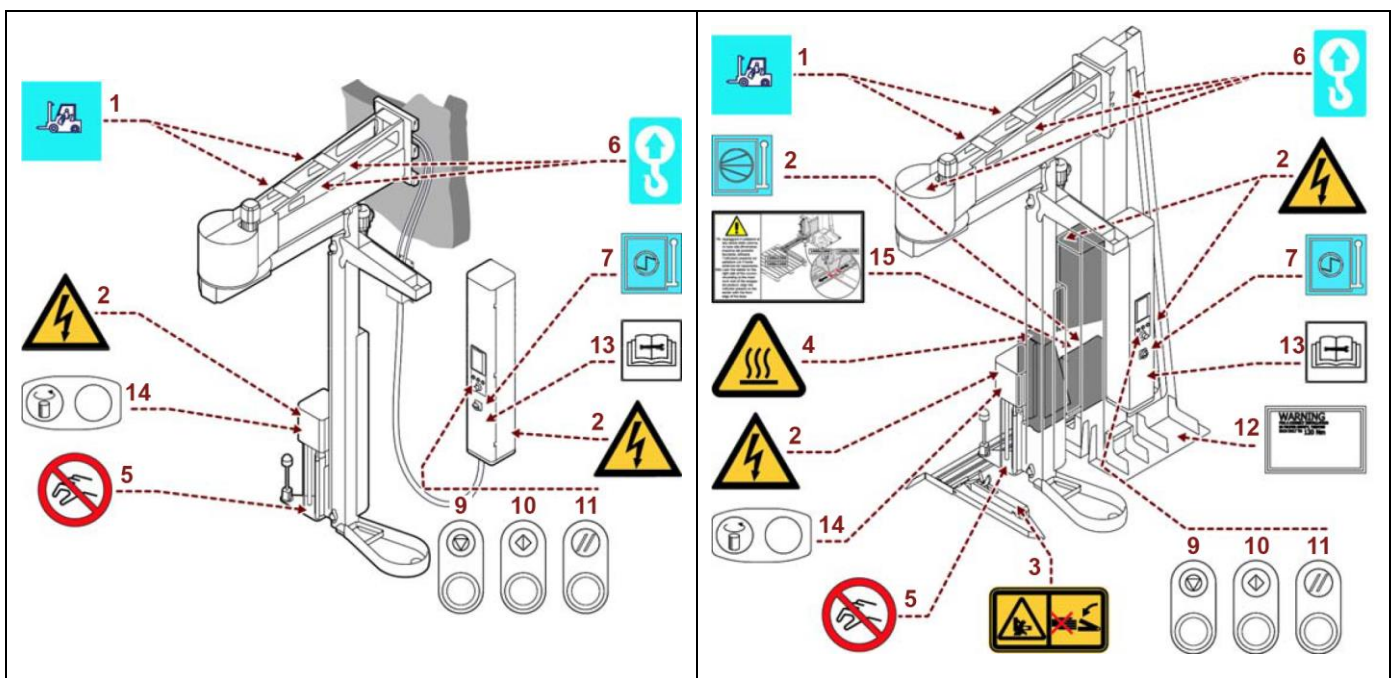

## 2.9. PERIMETER AREAS

The illustration shows the perimeter working areas of the machine.

- A) Operator standing area.
- B) Pallet loading/unloading area.
- C) Perimeter area.

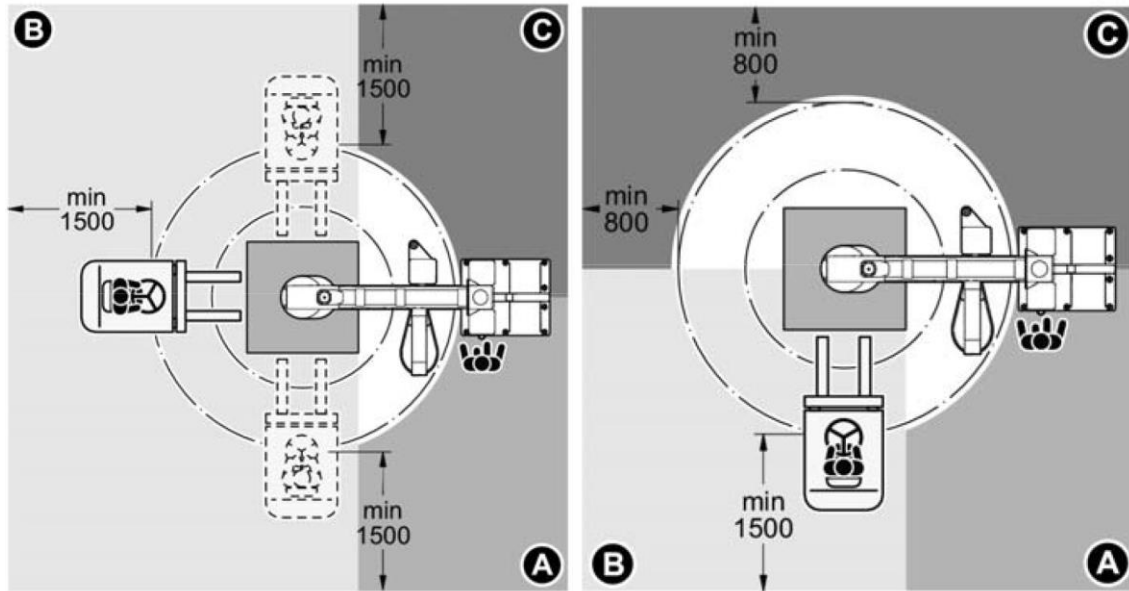

### 3. TECHNICAL INFORMATION

#### 3.1. MACHINE GENERAL DESCRIPTION

- The machine is a semi-automatic machine for palletised load wrapping and stabilising with stretch film.
- The machine must be used only for wrapping and stabilising products contained in packages (in boxes, liquid containers, etc.) with regular shape or with a shape that ensures a stable palletisation.
- Packages containing liquids or insubstantial materials must have characteristics suitable to the product and be perfectly closed and sealed to prevent the contents from flowing out.
- The machine consists of a rotary table, which makes the pallet turn, and a spool carriage which unwinds and stretches the film.
- The machine is equipped with a series of safety devices designed to avoid any injuries to the operator or other persons using the machine. It comes in different models to satisfy different market needs.
- Stretch film spools commonly available on the market are used for load wrapping.
- This machine is normally installed in workshops or industrial environments protected from the atmospheric agents.



**Danger - warning**

**Using this machine in explosive environments or when exposed to atmospheric agents is strictly forbidden.**

- The pallet loading and unloading are performed by the user, who can also insert and cut the film.
- Only one operator is required for its use.

The illustration shows, for information purposes only, the machine models, and the legend lists the parts.

**Legend:**

1. **Slide guide**  
It allows the film carriage to slide and wrap pallets with a standard maximum height of 2000 mm (2400-2750 mm on request).
2. **Arm motor**  
The motor drives the rotation of the arm.
3. **Rotating arm**  
It allows the rotation of the guide around the product.
4. **Carriage movement motor**  
The motor drives the film carriage.
5. **Control panel**  
It allows activating machine functions.
6. **Film carriage**  
It comprises a reel support that moves vertically to wrap the product.
7. **Pneumatic unit (optional)**  
It allows the movement of the cutting/sealing clamp and arm.
8. **Control panel support (optional)**  
In the wall-mounted version it supports the control panel box.
9. **Cutting and sealing unit (optional)**  
It allows sealing and cutting the film when the wrapping operation is completed.
10. **Column (only for the column version)**  
It supports the rotating arm and the electric control board.
11. **Fixed arm**  
It supports the rotating arm and the slewing ring for the rotation.

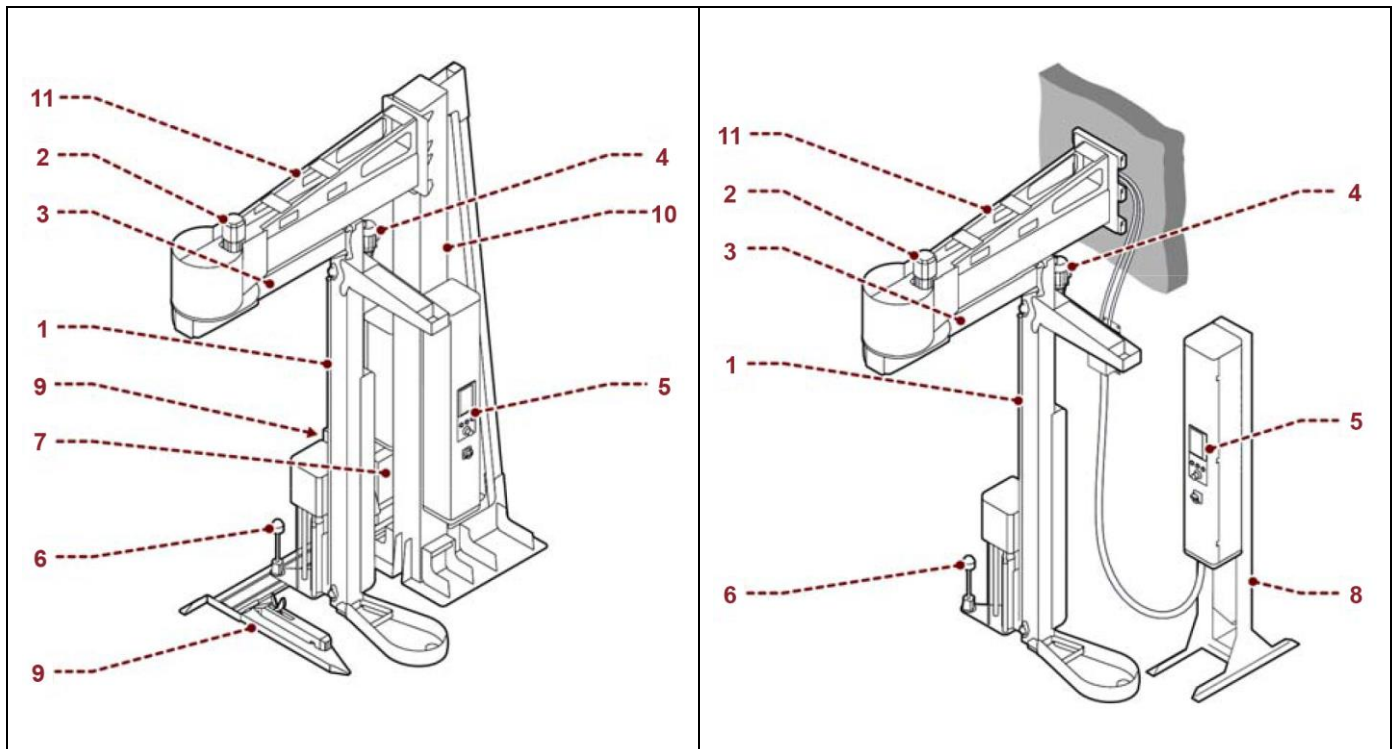

### 3.1.1. MACHINE MODELS DESCRIPTION

Table: Film carriage features

Film carriage type		General features
FR	h = 500mm h = 750 mm	Film carriage of "FR" type with friction roller, electromagnetic brake and film stretch adjustment from control panel.
PDS	h = 500mm h = 750 mm	Film carriage of "PDS" type with motorised pre-stretching rollers and electronically controlled film tensioning. Pre-stretch can be adjusted from the control panel (0%÷25%).
PVS	h = 500mm h = 750 mm	"PVS type film carriage"; dual-motor pre-stretch rollers and electronic film tensioning. Pre-stretch can be adjusted from the control panel (150%÷400%).

### 3.2. DESCRIPTION OF THE OPERATION CYCLE

#### Phase 1

The operator places the pallet in the centre of the machine and hooks the film to it.



#### Caution - warning

Risk of crushing upper limbs: do not insert the film in the clamp (if installed) by hand.

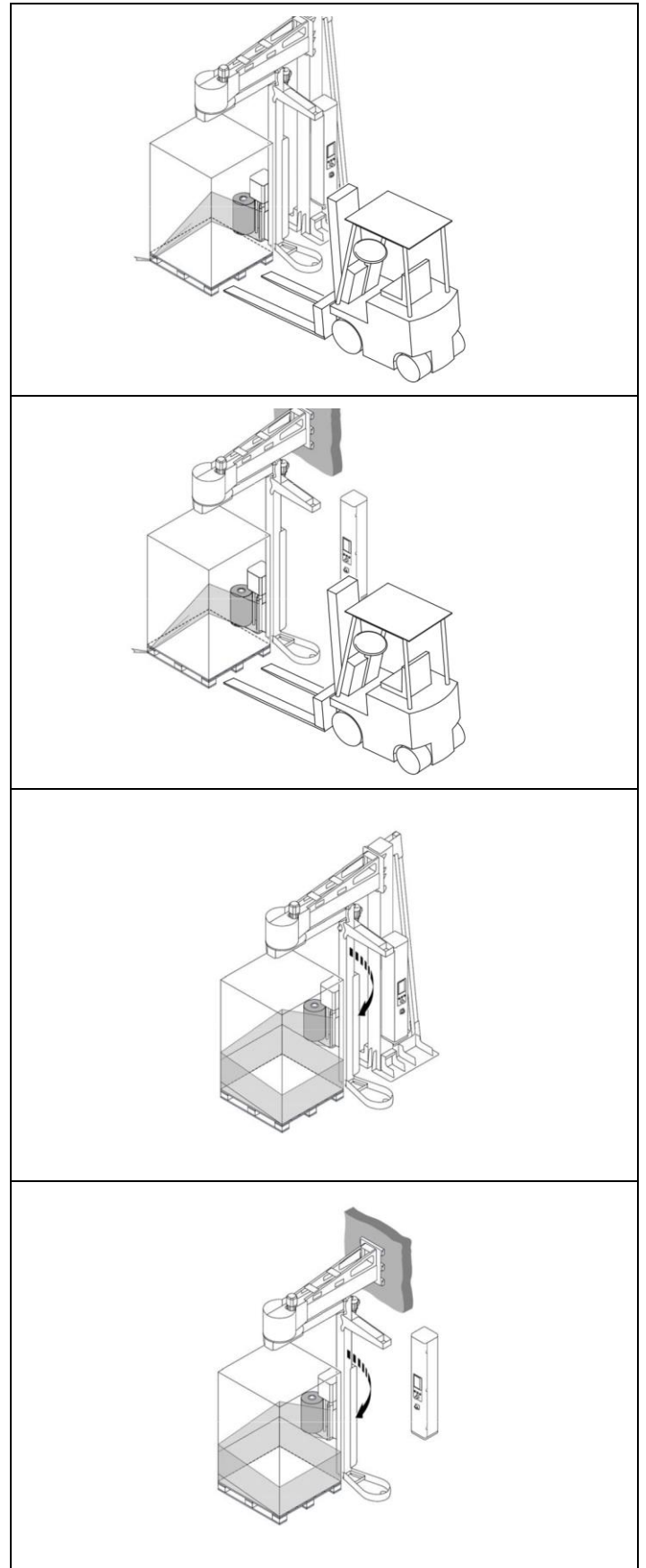

#### Phase 2

Once the cycle has started, the rotary arm starts to turn, while the film carriage unwinds the film, according to pre-set parameters.

**Phase 3**

Once the wrapping phase has ended, the machine stops and manual film cutting is necessary. The hot film cutting and sealing are performed automatically only if the optional fitting is installed.

**Phase 4**

The operator unloads the pallet. The cycle is complete and the machine is ready to start a new cycle.

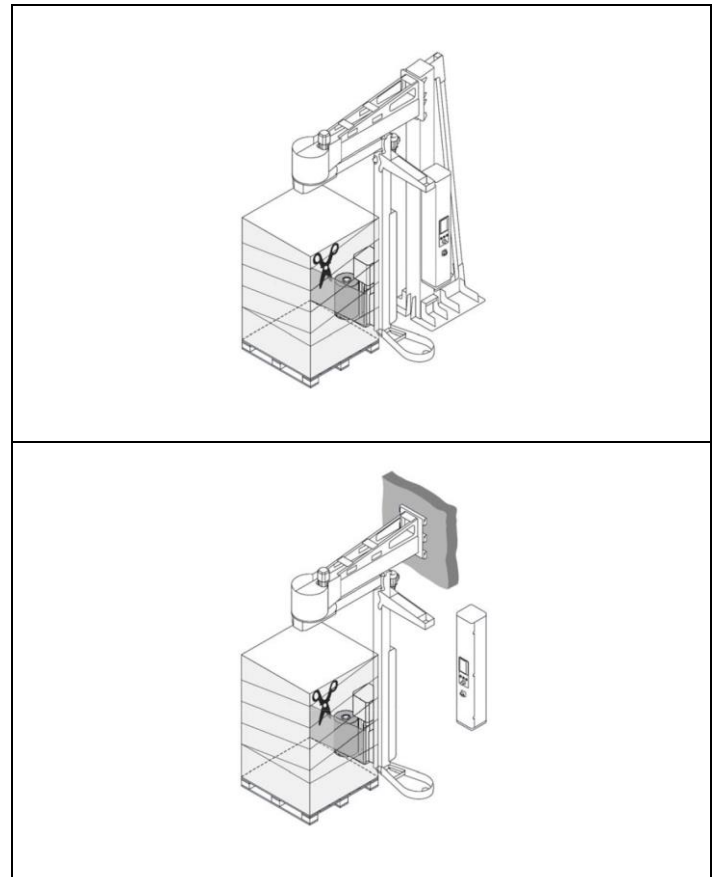

### 3.3. SAFETY DEVICE DESCRIPTION

The figure shows the position of the devices on the machine.

1. **A couple of photocells (transmitter-receiver) with safety control unit and safety buffer:**  
It controls the arm rotation stopping it in case of crash or intervention by unauthorised people
2. **Main switch:**  
It enables and disables the power supply. It can be locked to prevent unauthorised persons from enabling it during machine adjustment and maintenance phases.
3. **Acoustic signal:** it signals the wrapping cycle start.
4. **Emergency stop:** when pressed, it immediately stops the machine in emergency conditions.



**Danger - warning**

When the emergency button is pressed, the terminals of the motors may still be powered.

5. **Stack light:**
  - Fixed green light: it indicates that the machine is in a condition of safety operation.
  - Flashing red light: it indicates a current dangerous condition.
  - Flashing blue light: it indicates that the machine requires a manual action from the operator.
  - Flashing yellow light: it indicates that the machine is in a condition of potentially dangerous operation.



**Danger - warning**

The safety devices must be periodically checked to make sure that they are efficient.

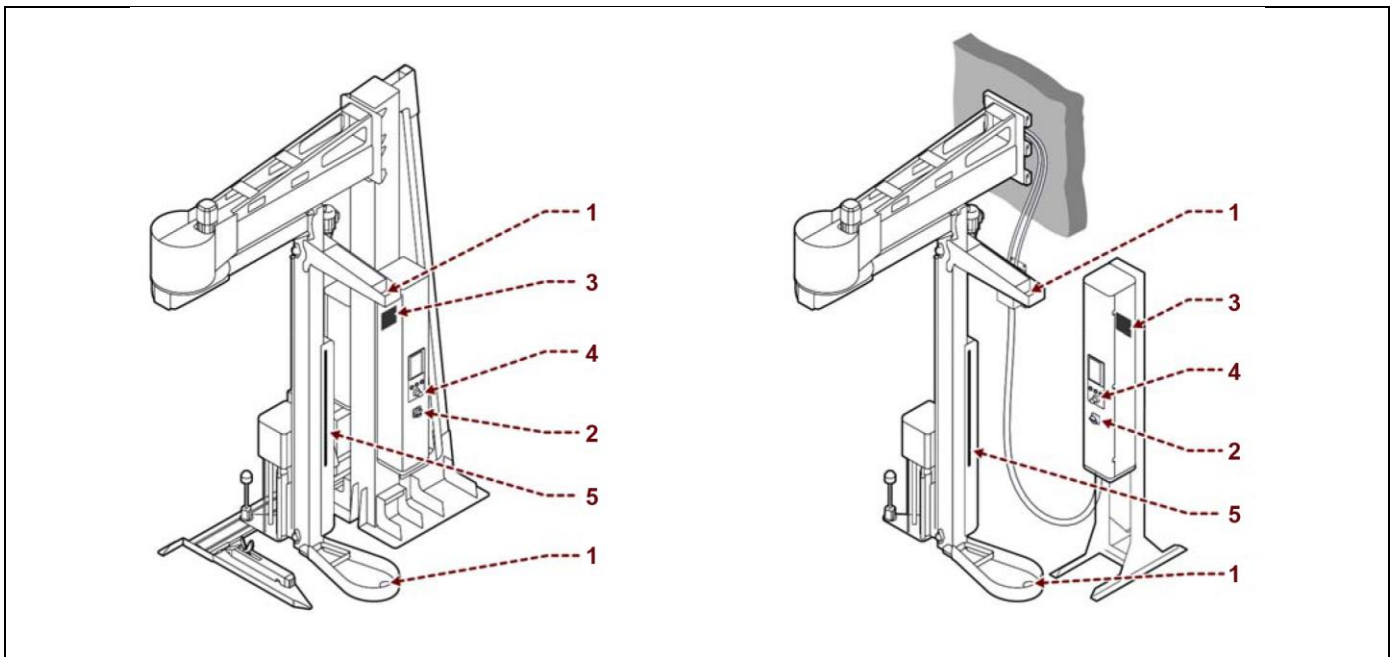

### 3.4. DESCRIPTION OF ELECTRICAL DEVICES

The figure shows the position of the devices on the machine.

1. **Photocell:**  
it detects the height and the presence of the load to be wrapped.
2. **Carriage limit microswitch:**  
it is activated when the film carriage reaches the minimum and maximum wrapping height.
3. **Timing sensor:**  
it detects the passage of the rotating arm from the starting position and counts the turns performed.
4. **Gearmotor:**  
it activates the film carriage movement.
5. **Gearmotor:**  
it activates the arm rotation.
6. **Motor (only PDS-PVS):**  
it activates the movement of the film unwinding roller.
7. **Motor (only PVS):**  
it activates the pre-stretch roller movement.
8. **"Load cell" sensor:**  
it detects the film tensioning and enables the variation of the film unwinding roller speed.



**Important**

For further details see the wiring diagram.

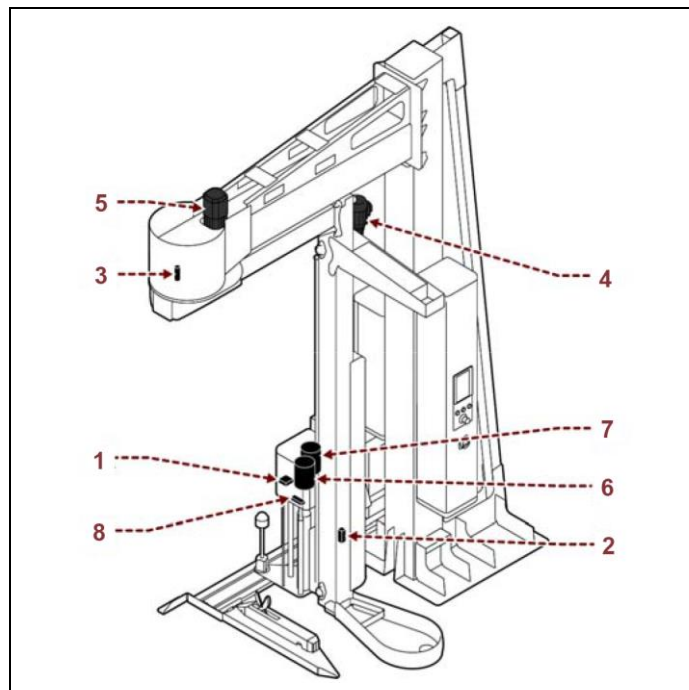

### 3.5. DESCRIPTION OF PNEUMATIC DEVICES (OPTIONAL)

The figure shows the position of the devices on the machine.

1. **Tap: to eliminate the pneumatic pressure**  
inside the machine.
2. **Pressure regulator with filter and pressure gauge:**  
It is used to adjust the general pressure of the system.  
Turn the knob to change the pressure values indicated on the pressure gauge.
3. **Solenoid valve:**  
To eliminate the pneumatic pressure inside the machine in case of emergency stop.
4. **Solenoid valve:**  
For moving the clamp.
5. **Solenoid valve:**  
For moving the sealing-cutting unit.
6. **Solenoid valve:**  
For starting the air blow device for turning over the clamp-side film.
7. **Solenoid valve:**  
For starting the air blow devices for collecting the film end.



**Important**  
For further details see the pneumatic diagram.

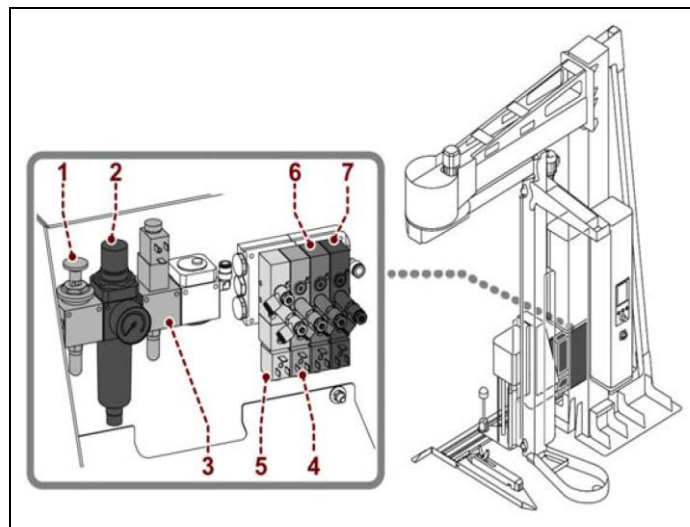

### 3.6. DESCRIPTION OF ACCESSORIES ON REQUEST

To increase the machine performance and versatility, the Manufacturer makes available the following accessories.

#### CW

Automatic cutting and sealing system.  
Automatic operation on film at the end of cycle.

The system comprises:

1. Clamping unit.
2. Sealing and cutting unit.

#### CS

Automatic spreading and sealing system.  
Automatic operation on film at the end of cycle.

The system comprises:

3. Clamping unit.
4. Spreading and cutting unit.

#### Slide guide (2400 - 2750 mm)

Maximum wrappable height 2400 mm.

Maximum wrappable height 2750 mm.

To wrap pallets which are higher than the standard ones.

#### Reel-holder shaft $\varnothing$ 50 mm (CORE - CORELESS version)

#### 5. Mechanical presser:

Electrically controlled device for load stabilisation, it is not necessary to adjust the height according to the size of the product to be wrapped.

#### 6. Creasing device:

It is used during wrapping to gather the film in one point, providing the package with a reinforcement point.

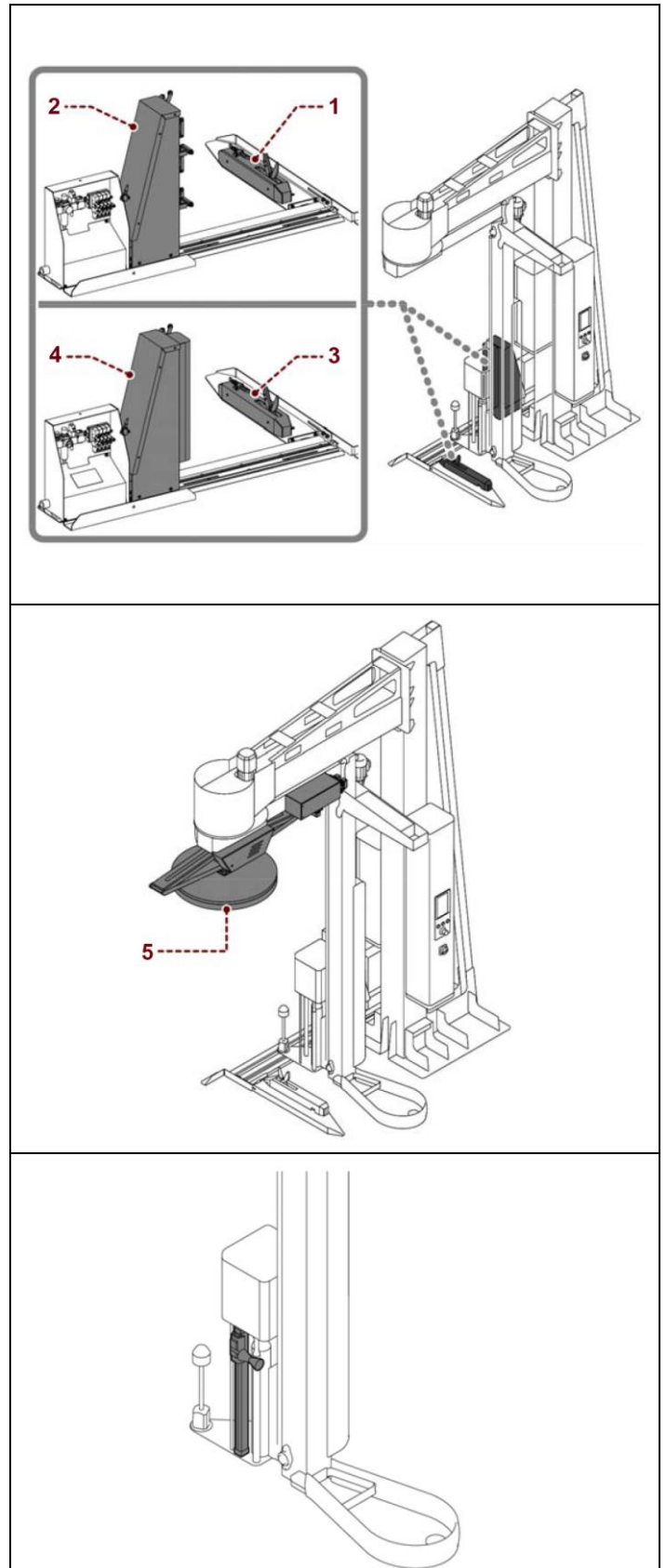

### 3.7. TECHNICAL SPECIFICATIONS

Description	Unit of measurement	Value		
Carriage		308 FR	508 PDS	708 PVS
Supply voltage		1 Ph + N 230V 50Hz		
Installed power	kW	1.5 / 1.8	1.9 / 2.2	2.3 / 2.6
Arm rotation speed	Rpm	12		
Adjustable carriage upstroke/downstroke speed	m/min	2.5 ÷ 5.5 (For 500 mm carriage) 4 ÷ 9 (For 750 mm carriage)		
Product dimensions L x W	mm	400x400 ÷ 1400x1400		
Overall weight	kg	760 ÷ 820		
Ambient operating temperature	°C	0 ÷ 40		

#### 3.7.1. CLAMPING, CUTTING AND SEALING (OPTIONAL)

Description	Unit of measurement	Value
Working pressure	bar MPa	6 (±1) 0.6 (±0.1)
Air consumption	NI/min	4.5

#### 3.7.2. SPOOL FEATURES

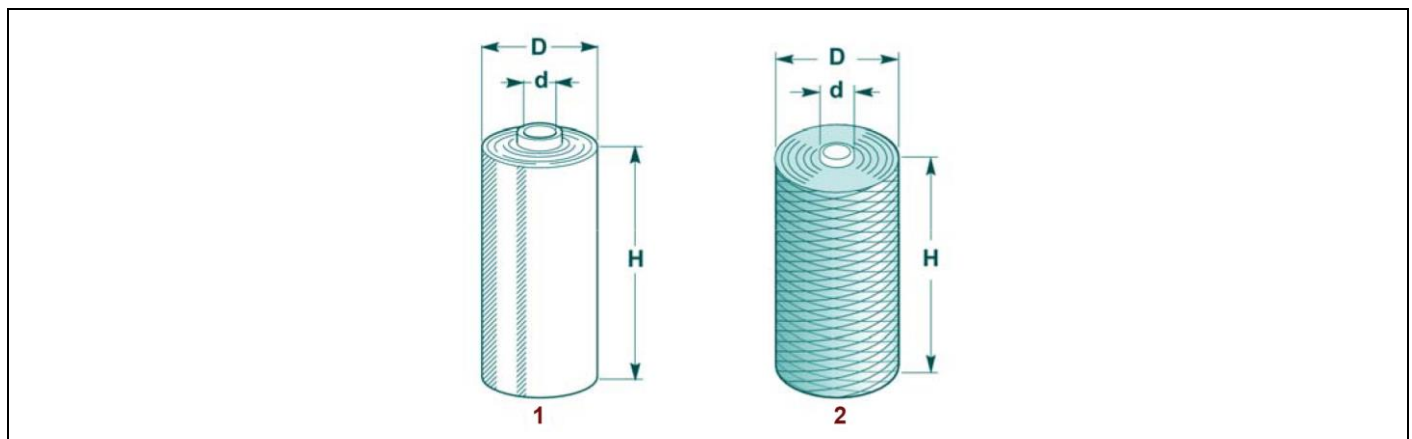

Description	Unit of measurement	Value
<b>Film reel dimensions (1)</b>		
Maximum outer diameter (D)	mm	300
Reel height (H)	mm	500 – 750
Film thickness	µm	17÷35
Internal diameter (d)	mm	Ø 76
Max. weight	kg	30
<b>Mesh reel dimensions (2)</b>		
Maximum outer diameter (D)	mm	300
Reel height (H)	mm	500 – 750
Internal diameter (d)	mm	Ø 76
Max. weight	kg	30

### 3.7.3. PRODUCT DIMENSIONS

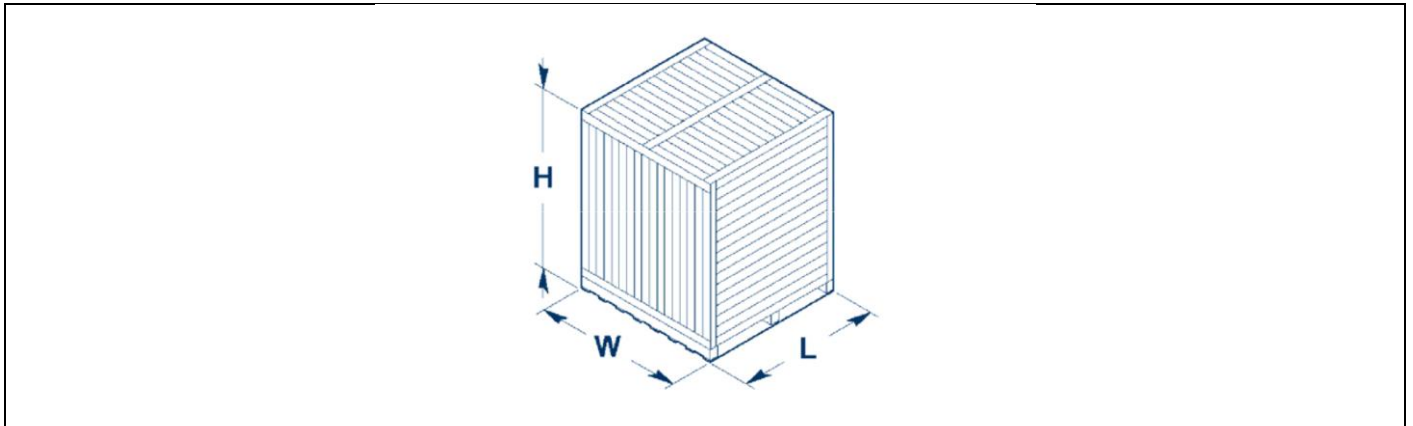

Description		Unit of measurement	Value
L x W	Minimum dimensions	mm	400x400
L x W	Maximum dimensions	mm	1200x1200 1400x1400
H	Maximum height	mm	2000 (STD) 2400 (OPT) 2750 (OPT)

### 3.7.4. MACHINE DIMENSIONS

The illustration and the table include the machine dimensional specifications and technical data.

#### Column-type Rotary

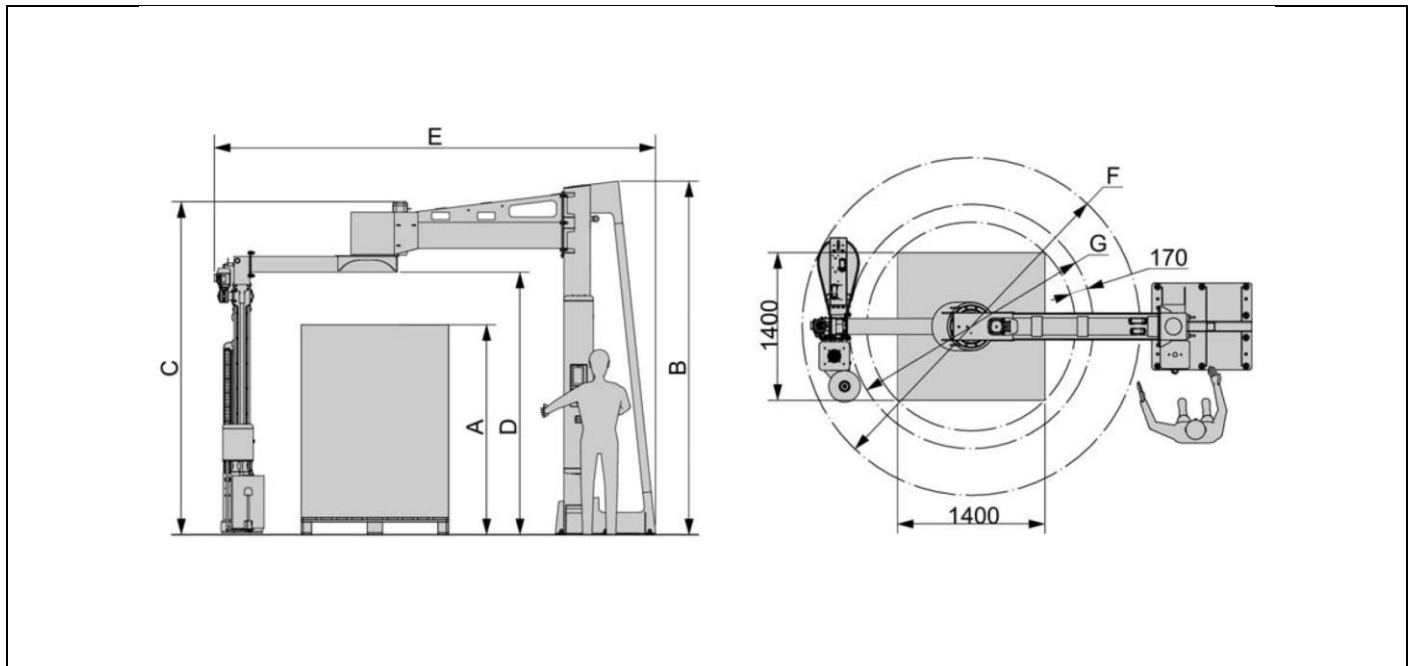

	<b>1200x1200</b>	<b>1400x1400</b>
A (mm)	2000 / 2400 / 2750	2000 / 2400 / 2750
B (mm)	3366 / 3761 / 4107	3366 / 3761 / 4107
C (mm)	3171 / 3571 / 3921	3171 / 3571 / 3921
D (mm)	2500 / 2900 / 3250	2500 / 2900 / 3250
E (mm)	4044	4190
F (mm)	2951	3207
G (mm)	2037	2320

### Wall-mounted Rotary

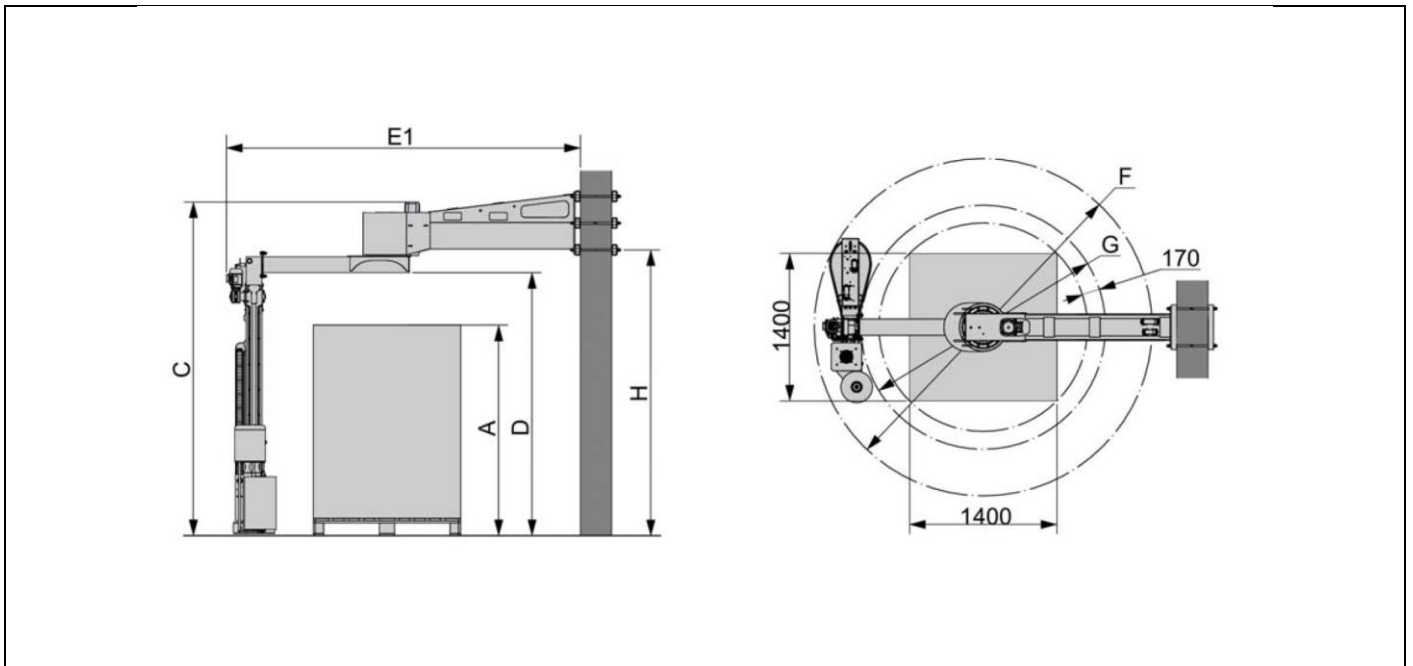

	<b>1200x1200</b>	<b>1400x1400</b>
<b>A (mm)</b>	2000 / 2400 / 2750	2000 / 2400 / 2750
<b>C (mm)</b>	3171 / 3571 / 3921	3171 / 3571 / 3921
<b>D (mm)</b>	2500 / 2900 / 3250	2500 / 2900 / 3250
<b>E1 (mm)</b>	3214	3360
<b>F (mm)</b>	2951	3207
<b>G (mm)</b>	2037	2320
<b>H (mm)</b>	2715 / 3115 / 3465	2715 / 3115 / 3465

Rototech

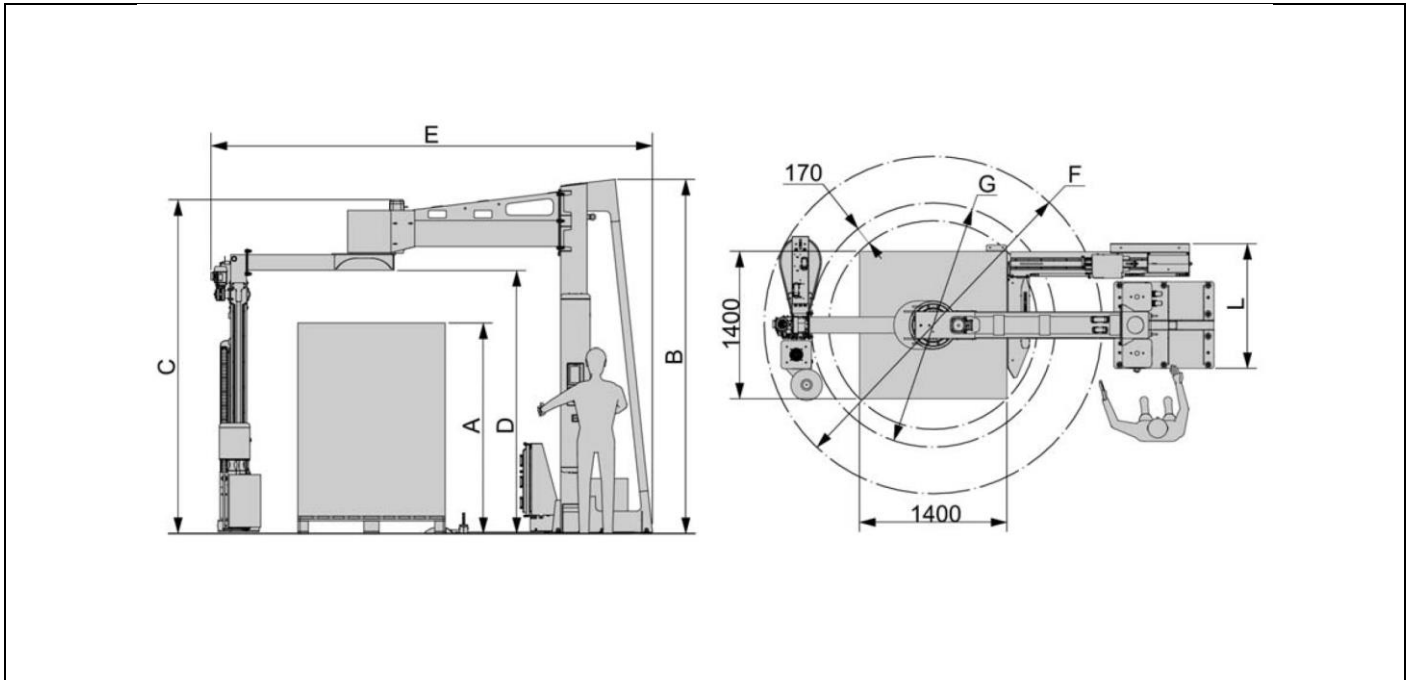

	1200x1200	1400x1400
A (mm)	2000 / 2400 / 2750	2000 / 2400 / 2750
B (mm)	3366 / 3761 / 4107	3366 / 3761 / 4107
C (mm)	3171 / 3571 / 3921	3171 / 3571 / 3921
D (mm)	2500 / 2900 / 3250	2500 / 2900 / 3250
E (mm)	4044	4190
F (mm)	2951	3207
G (mm)	2037	2320
L (mm)	1183	1183

### 3.8. NOISE LEVEL

The values relating to airborne noise have been detected in compliance with standards:

- UNI EN ISO 3744
- EN ISO 11201

Description	Sound pressure level (L <sub>pf</sub> )	Emitted sound power level (L <sub>w</sub> )	Level at operator position (L <sub>op</sub> )
Operation in working conditions	70.0 dB (A)	92.5 dB (A)	69.3 dB (A)



**Caution - warning**

Prolonged exposure above **80 dB (A)** can be harmful.



The use of appropriate protection systems is recommended (earmuffs, ear plugs, etc.).

### 3.9. INSTALLATION ENVIRONMENT CHARACTERISTICS

The place where the machine is to be installed must be carefully selected taking into account the environment conditions in order to have correct and risk-free operating conditions.

Therefore we suggest to take into account the following prerequisites:

- An appropriate ambient temperature (see "Technical data").
- A perimeter area that must be left around the immediate working area, also for safety reasons (see "Perimeter areas").
- A flat surface, steady and without vibrations with adequate load bearing capacity, considering also the weight of palletised loads.
- The area must feature suitable sockets for compressed air and power distribution.



**Danger - warning**

Using this machine in explosive environments or when exposed to atmospheric agents is strictly forbidden.

## 4. INFORMATION ON HANDLING AND INSTALLATION

### 4.1. RECOMMENDATIONS FOR HANDLING AND LOADING

- Before performing any operation, the authorised operator must make sure to have understood the “Instructions for use”.
- Carefully read the “Instructions for use” specified in the manual and those applied directly to the machine and/or the package.
- Provide suitable safety conditions in compliance with the regulations on workplace safety to prevent and minimise the risks.
- Pay attention to the safety warnings, do not misuse the machine and assess the possible residual risks.

### 4.2. PACKING AND UNPACKING

The packing is realised, keeping the overall dimensions limited, also in consideration of the transport chosen. To facilitate transport, shipping can be performed with some components disassembled and appropriately protected and packaged.

Some parts, especially electrical equipment, are protected with anti-moisture nylon covers.

The packages bear all necessary information for loading and unloading.

When unpacking, check the integrity and exact quantity of the components.

Packaging material should be appropriately disposed of according to the laws in force.

The illustrations show the common types of packaging used.

#### Package on pallet with nylon protection

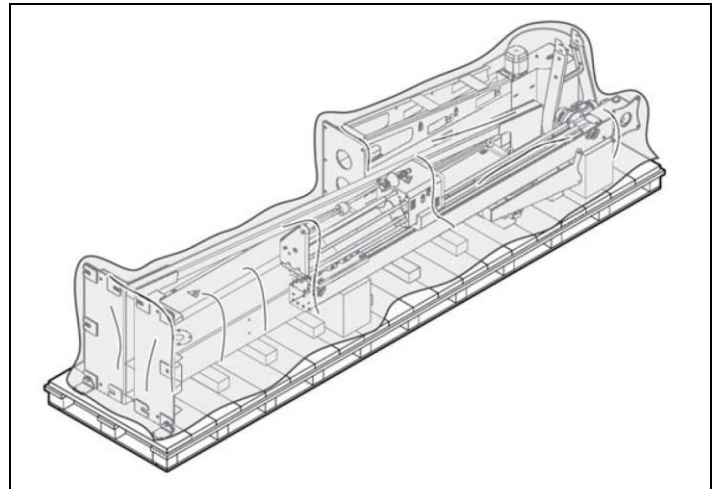

#### Package in crate

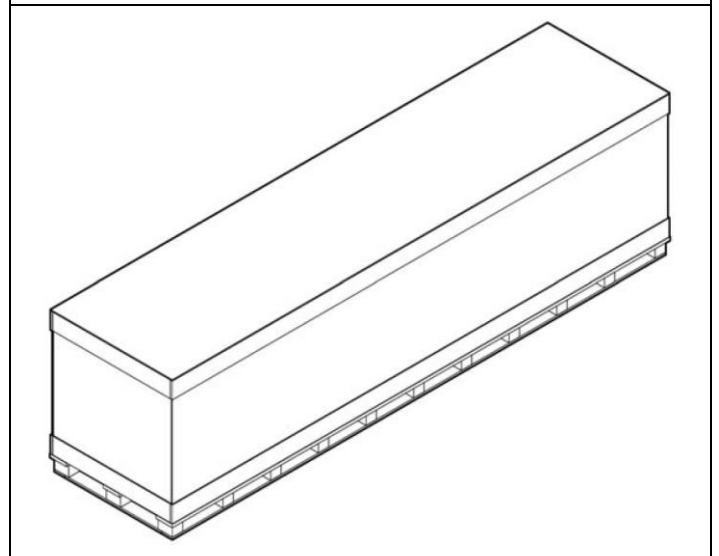

### 4.3. TRANSPORT AND HANDLING

Transport, also according to the destination, can be performed with different vehicles.  
The diagram represents the most used solutions.

During transport, in order to avoid sudden movements, adequately anchor the machine to the vehicle.



**Important**

For further transportations, recreate the initial packaging conditions for transport and handling.

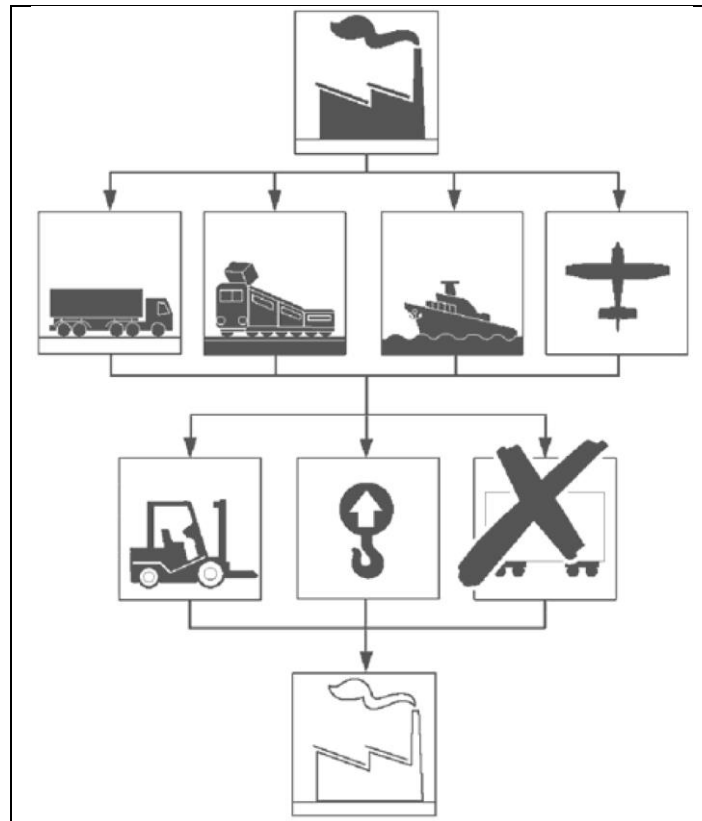

**Caution - warning**

Before lifting, check the position of the load's centre of gravity.

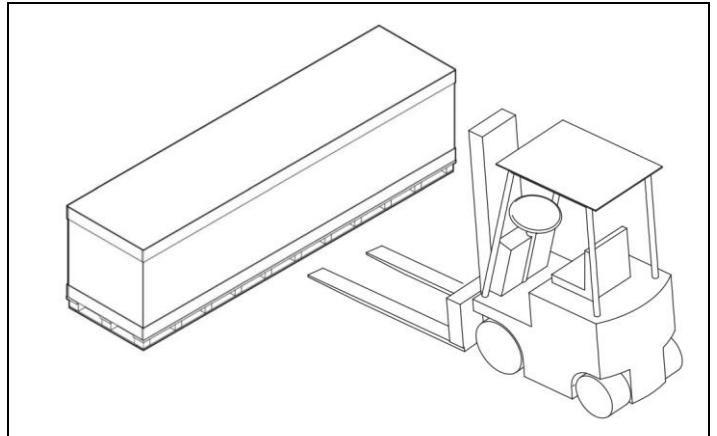
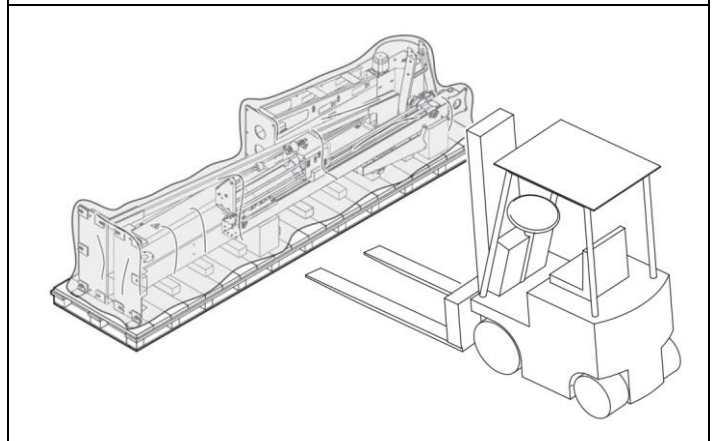
**Package in crate****Package on pallet**

## 4.4. INSTALLATION OF THE MACHINE

### 4.4.1. MACHINE INSTALLATION IN COLUMN VERSION

Depending on the floor type, it may be necessary, before laying the machine, to lay foundations in correspondence of the various supporting legs.

The fastening of this kind of machines requires an industrial floor with:

- Uncracked concrete foundations with strength class  $\geq C20/25$ .
- Minimum thickness **170 mm**.
- Metal reinforcing cage with **10 mm** diameter rods.



#### Important

Laying the foundations and fixing the machine is essential to ensuring the machine stability and functionality.

1. Cut the straps fastening the machine to the pallet.
2. Lift the fixed and rotating arm from the pallet, inserting the lift forks in the marked positions (A).
3. Rest the machine parts near the installation point.
4. Remove the mounting brackets for transport (B).

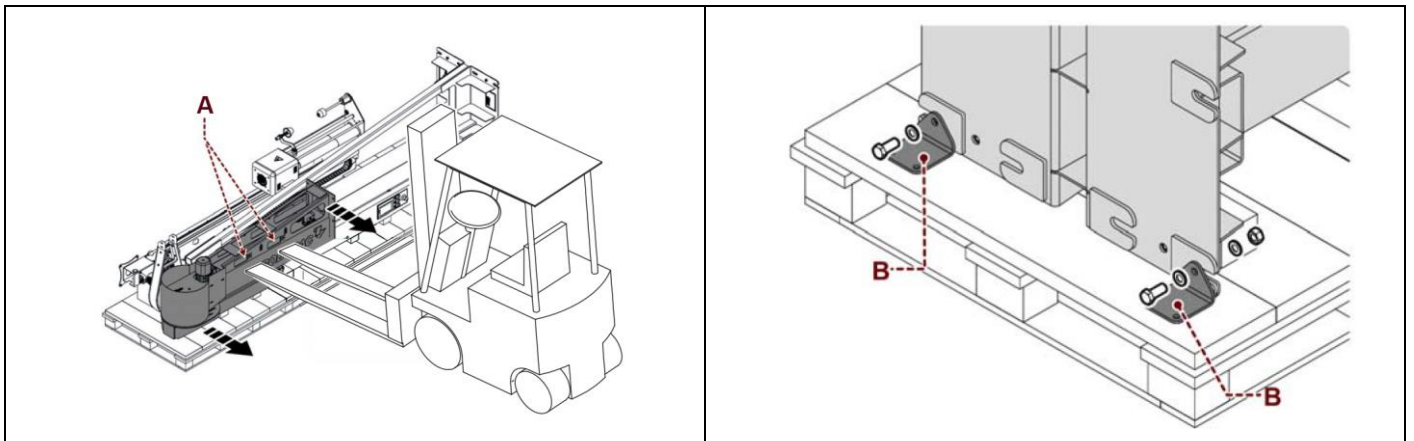

5. Lift the column and the complete carriage guide from the pallet by using the provided lifting points.

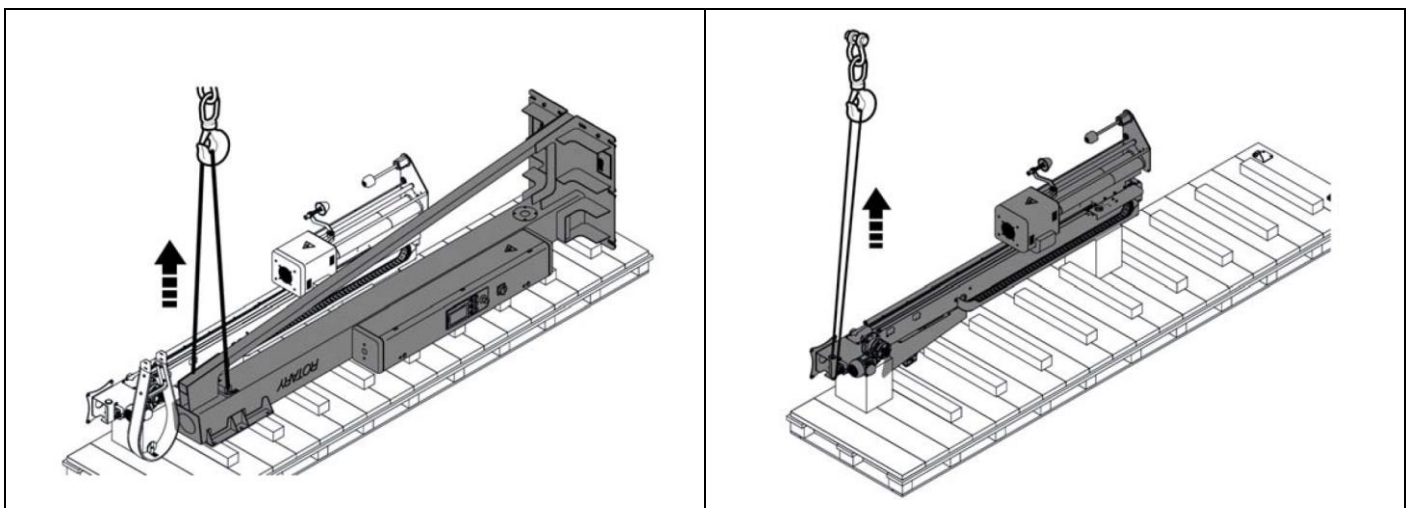

6. Rest the column against the chosen installation location and make the 8 required holes.
7. Clean well the holes as shown.

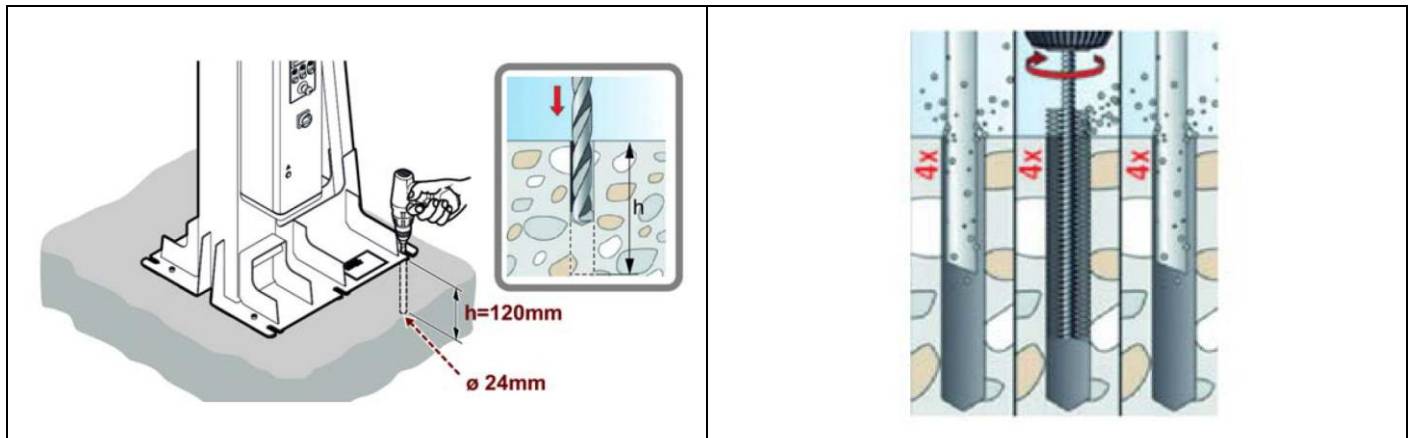

8. Block the threaded rods provided with FIS V chemical two-component vinylester-based hybrid injection fixing. Extrude the FIS V chemical fixing without air bubbles starting from the bottom of the hole. Information on how to apply the chemical fixing and the workability/waiting time before loading, follow the indications of the following table.

Cartridge temperature (resin)	Workability time	Support temperature	Time before loading
		- 5 °C - ± 0 °C	24 h
± 0 °C - + 5 °C	13 min.	± 0 °C - + 5 °C	3 h
+ 5 °C - + 10 °C	9 min.	+ 5 °C - + 10 °C	90 min.
+ 10 °C - + 20 °C	5 min.	+ 10 °C - + 20 °C	60 min.
+ 20 °C - + 30 °C	4 min.	+ 20 °C - + 30 °C	45 min.
+ 30 °C - + 40 °C	2 min.	+ 30 °C - + 40 °C	35 min.

The above-mentioned time starts from the moment in which the resin and the toughener are in contact with each other in the mixer.

For installation the cartridge temperature must be at least +5 °C.

For longer installation time, for example when work is interrupted, the mixer must be replaced.

9. Fix the column to the ground with the nuts (C).

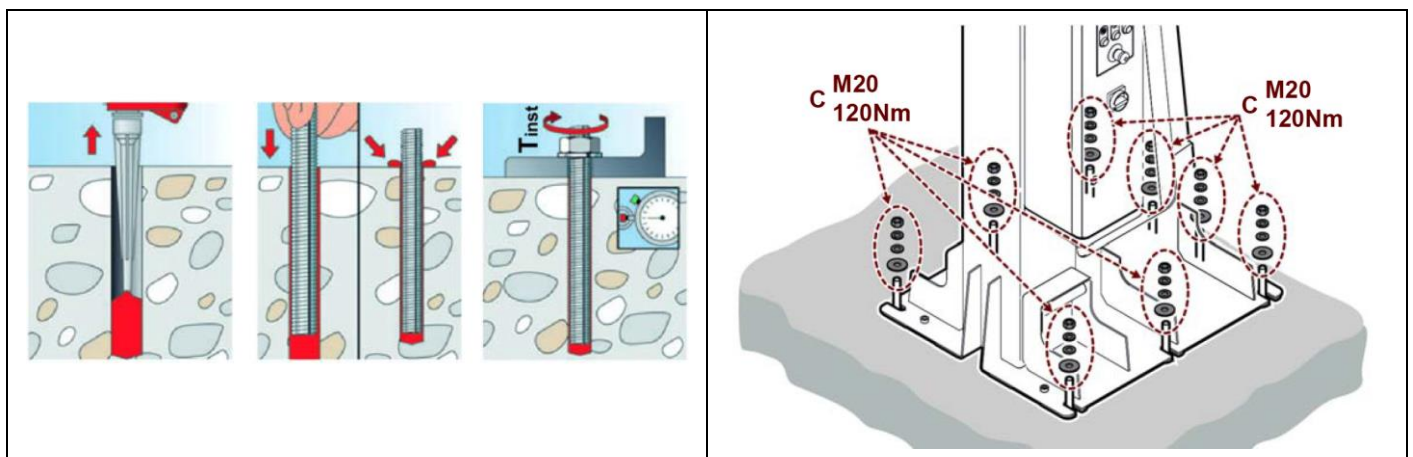

10. Level by means of the screws (D) and use the shims (E) supplied to secure the position.
11. Lift the fixed-rotating arm with proper lifting means and fix it to the column with the screws (F).  
Level by means of the screws (G).  
Connect the plugs (H) to the provided sockets.

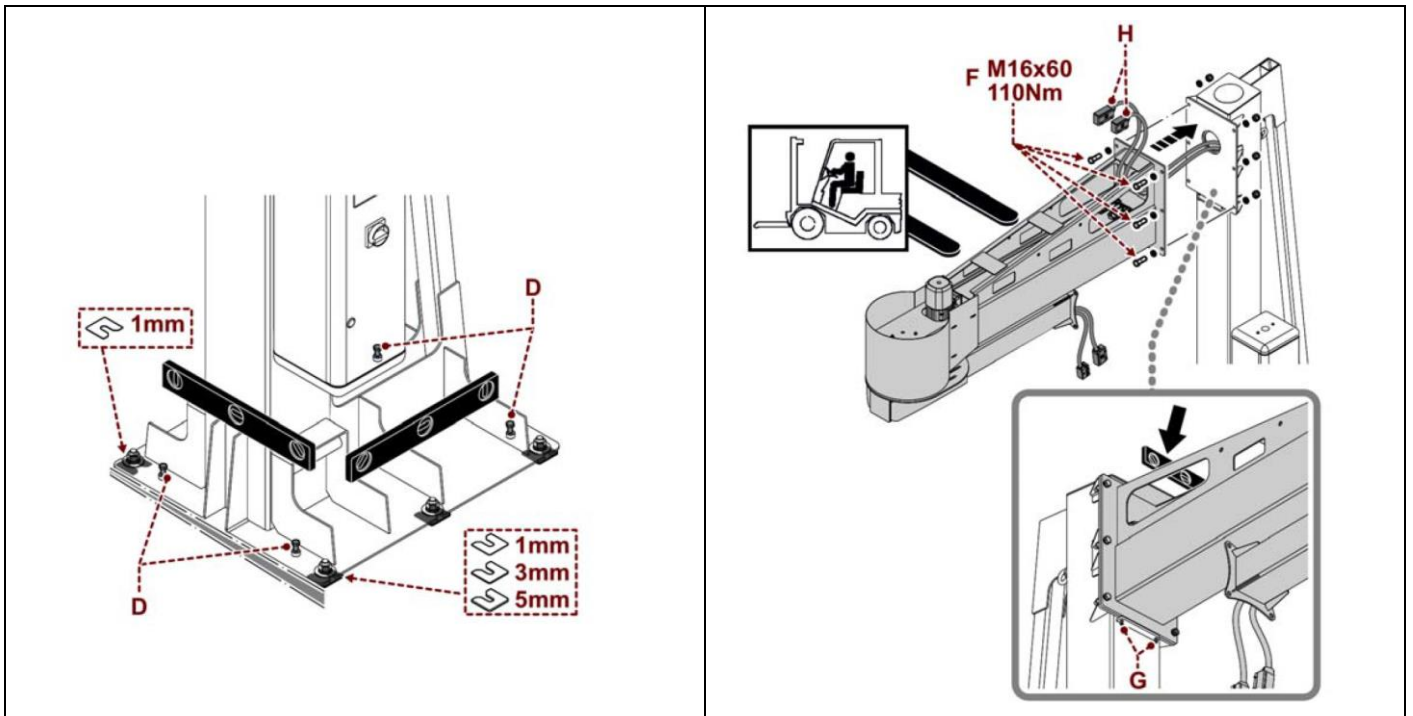

12. Adjust the position of the rotating arm according to the maximum size of the product to be wrapped.  
Loosen screws (Q).  
Move the arm and fix the position by tightening the screws (Q).
13. Lift the carriage guide with proper lifting means and fix it to the rotating arm with the screws (I).  
Lift the support (L) and fasten it with the screws (M).  
Connect the plugs (N) to the provided sockets.

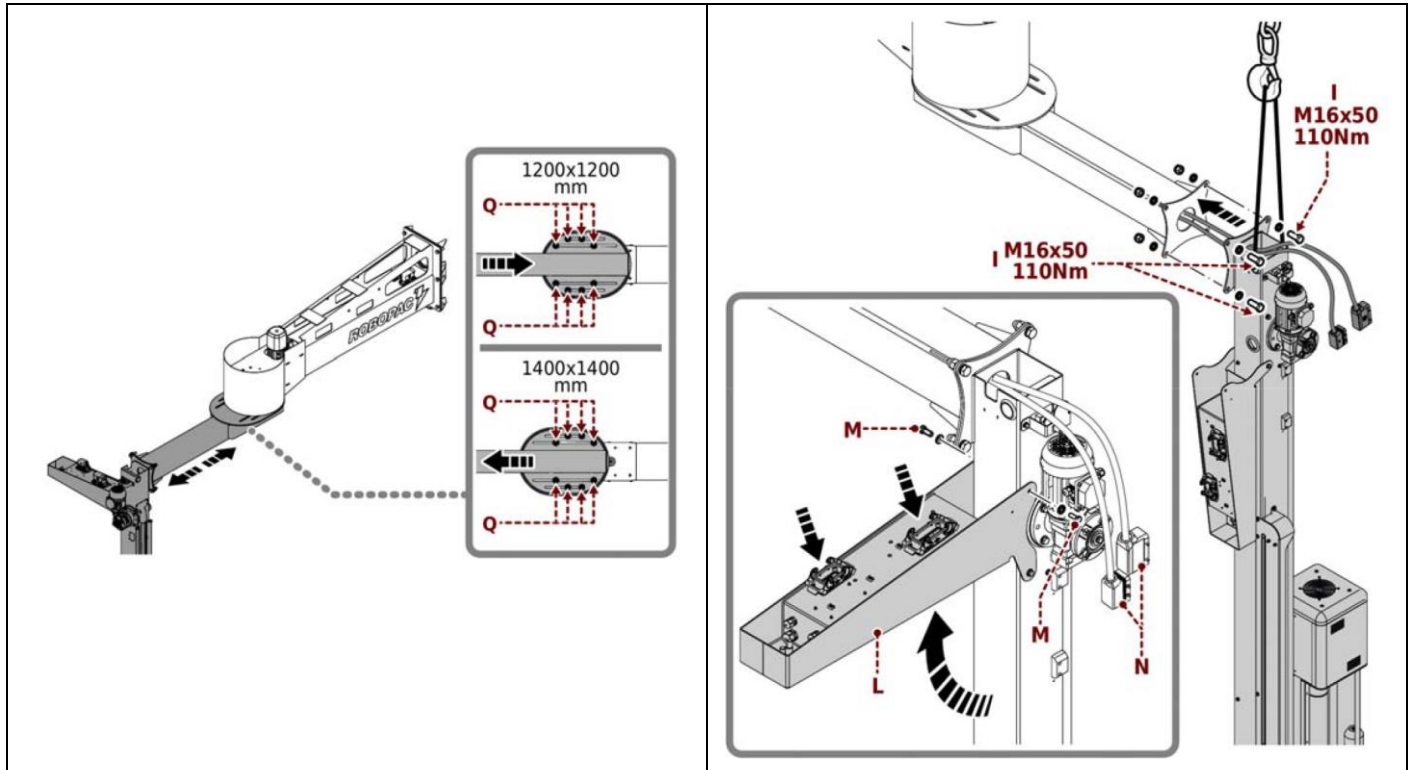

14. Fit the safety buffer with the screws (O) and the plates (P).

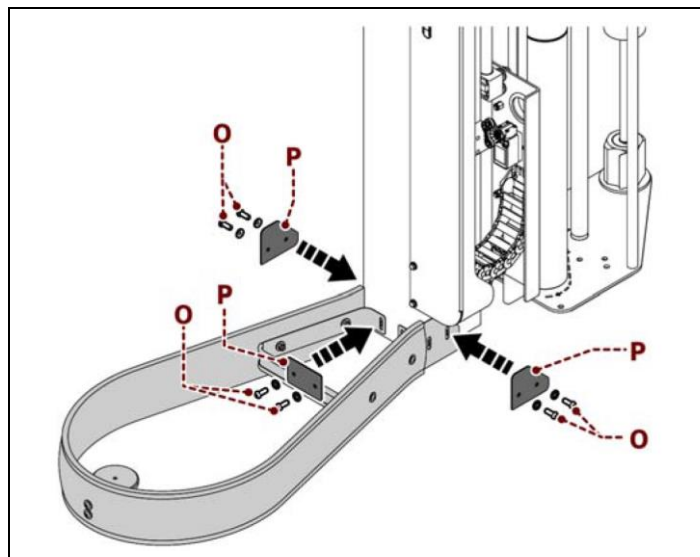

#### 4.4.2. WALL-MOUNTED MACHINE INSTALLATION

1. Cut the straps fastening the machine to the pallet.
2. Lift the fixed and rotating arm from the pallet, inserting the lift forks in the marked positions (A).
3. Rest the machine parts near the installation point.
4. Lift the complete carriage guide from the pallet by using the provided lifting points.
5. The fastening of this machine version requires a wall (or any other support element) capable of bearing a bending moment of  $M=2000 \text{ Kg.m}$ .  
For securing it, use the 6 M16 fastening tie rods supplied.



**Danger - warning**

Do not use the control panel before all the parts comprising the machine have been installed.

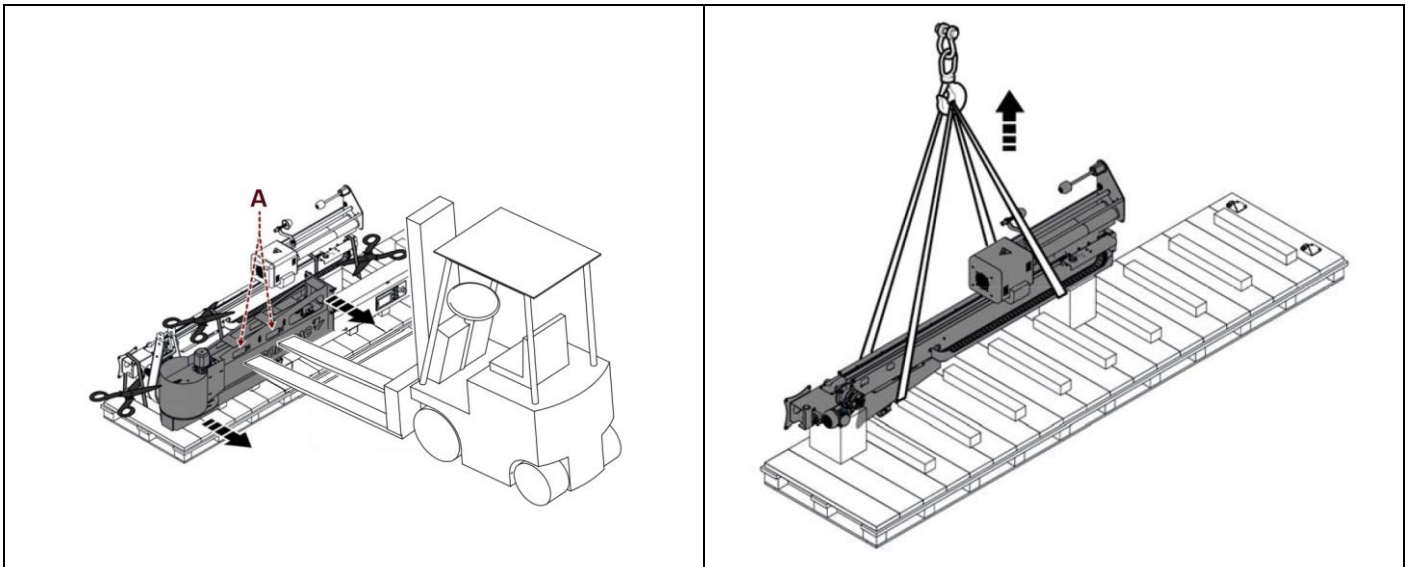

6. Determine the height (**h**) according to the “technical data” chapter.  
 Lift the fixed-rotating arm with proper lifting means and secure it to the bearing element with tie rods (**C**) and brackets (**D**).  
 Wall-mounting with  $\varnothing 20$  through holes or column-fastening by embracing the column itself.

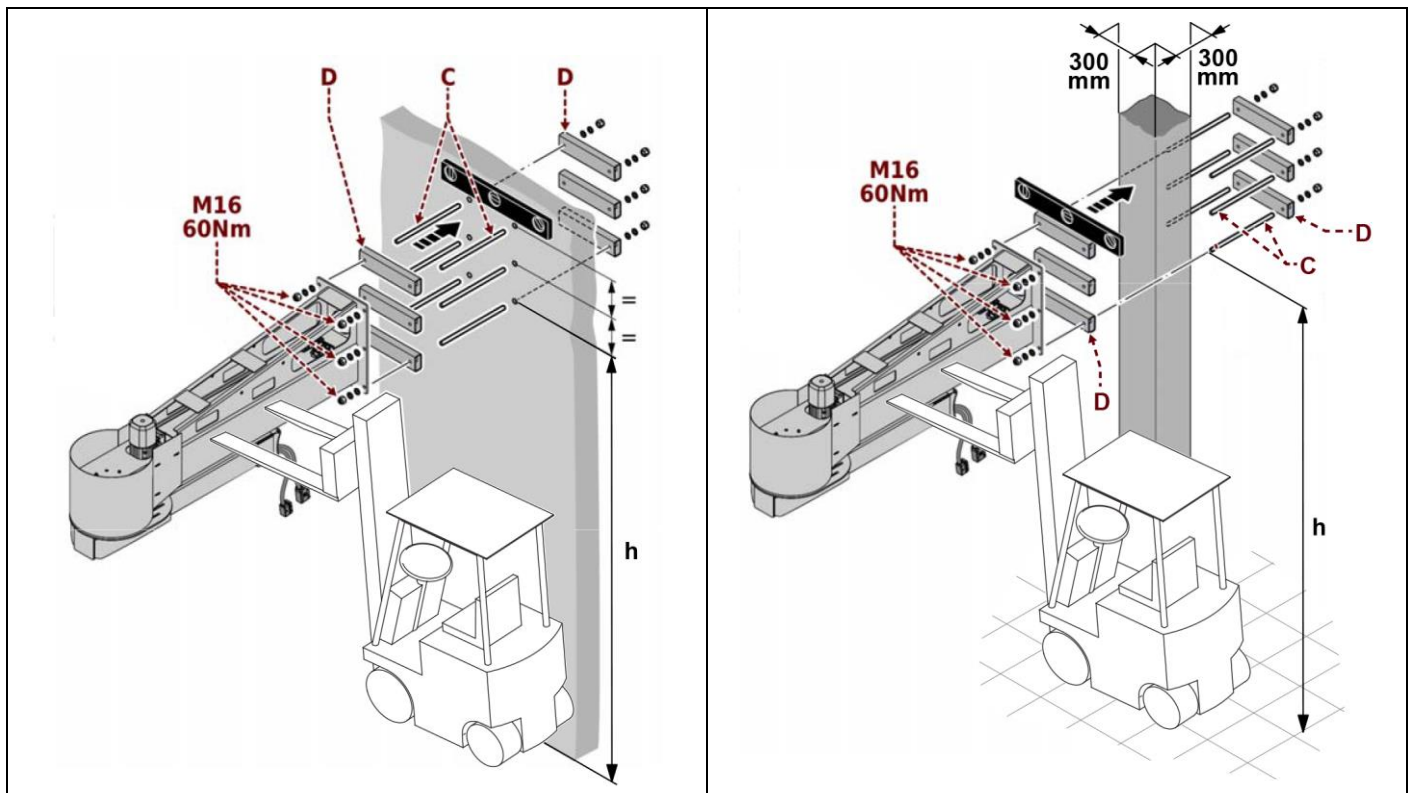

7. Adjust the position of the rotating arm according to the maximum size of the product to be wrapped.  
 - Loosen screws (**Q**).  
 - Move the arm and fix the position by tightening the screws (**Q**).

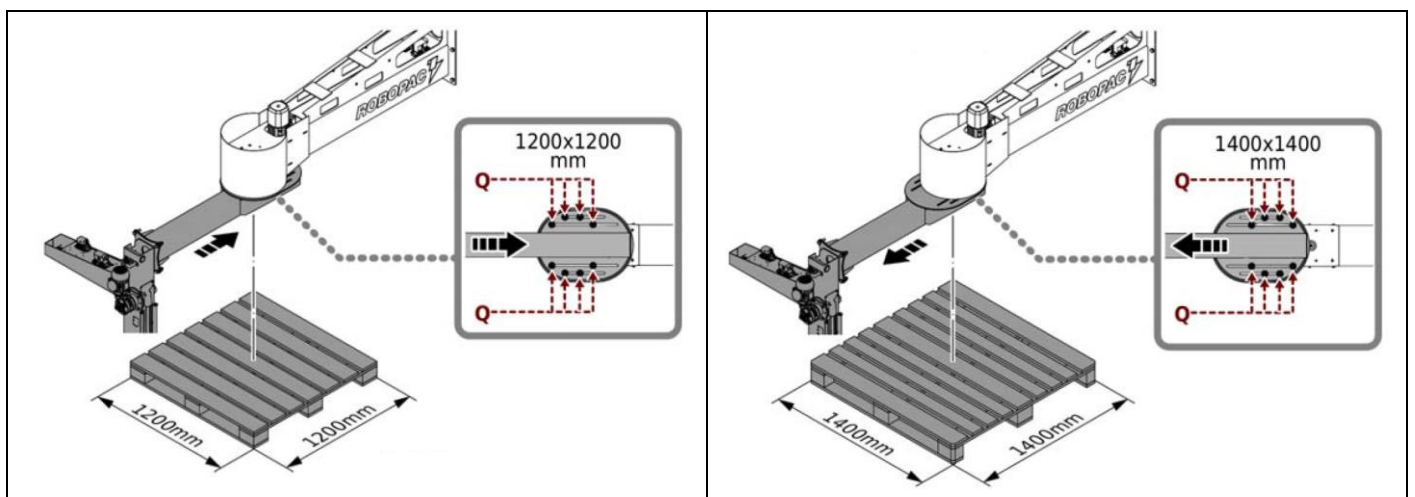

8. Lift the carriage guide with proper lifting means and fix it to the rotating arm with the screws (I).  
Lift the support (L) and fasten it with the screws (M).  
Connect the plugs (N) to the provided sockets.

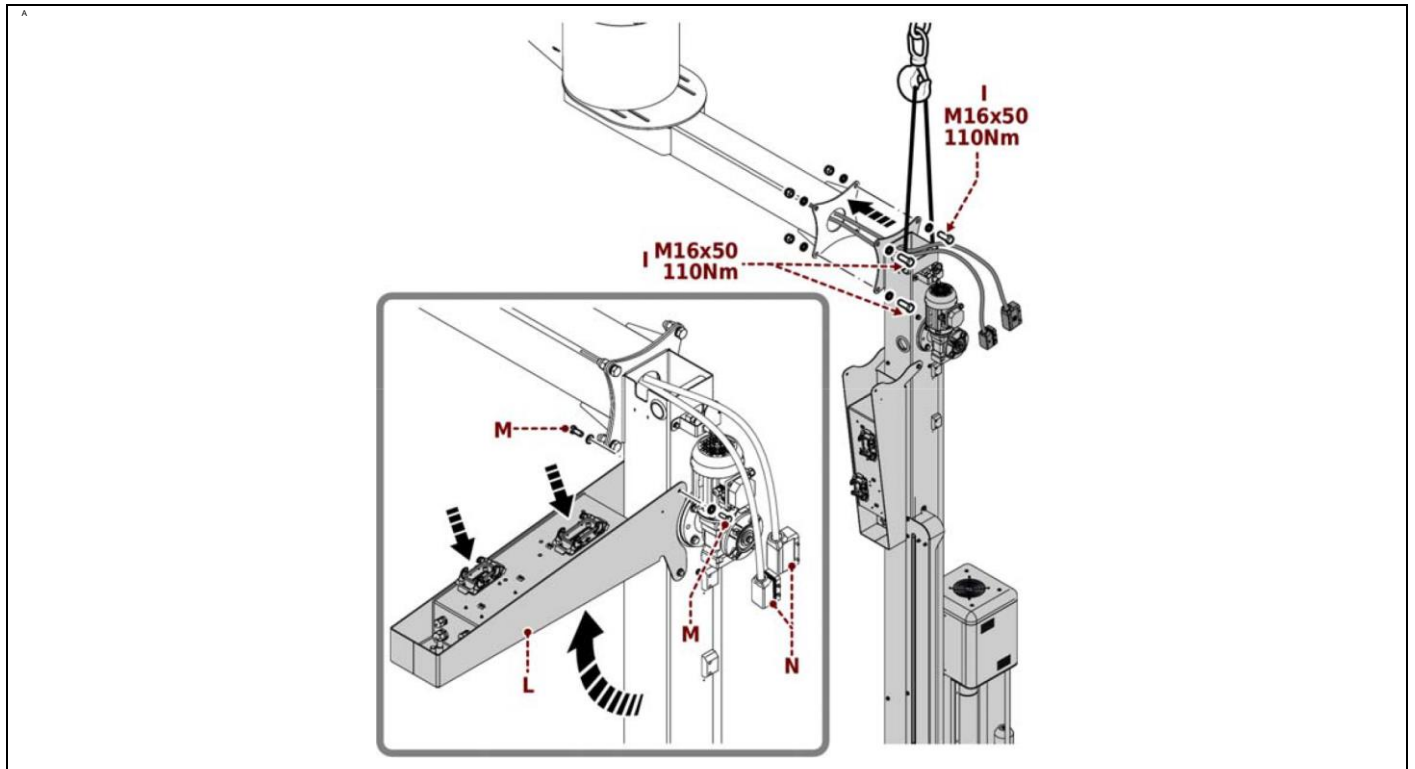

9. Fit the safety buffer with the screws (O) and the plates (P).

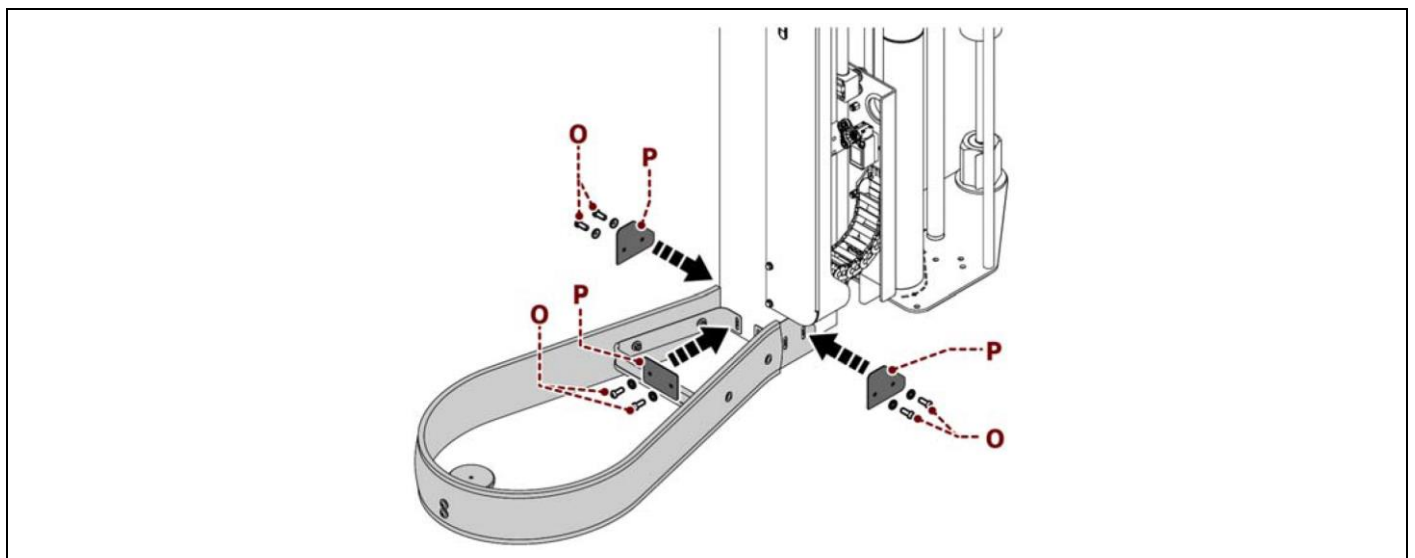

10. Fit the electric control board in the desired position with 4 M8 plugs (T). If the support is provided, place it near the machine.  
 Fit the junction box (R) with 4 M10 plugs (S).  
 Connect the plugs (H) to the provided sockets

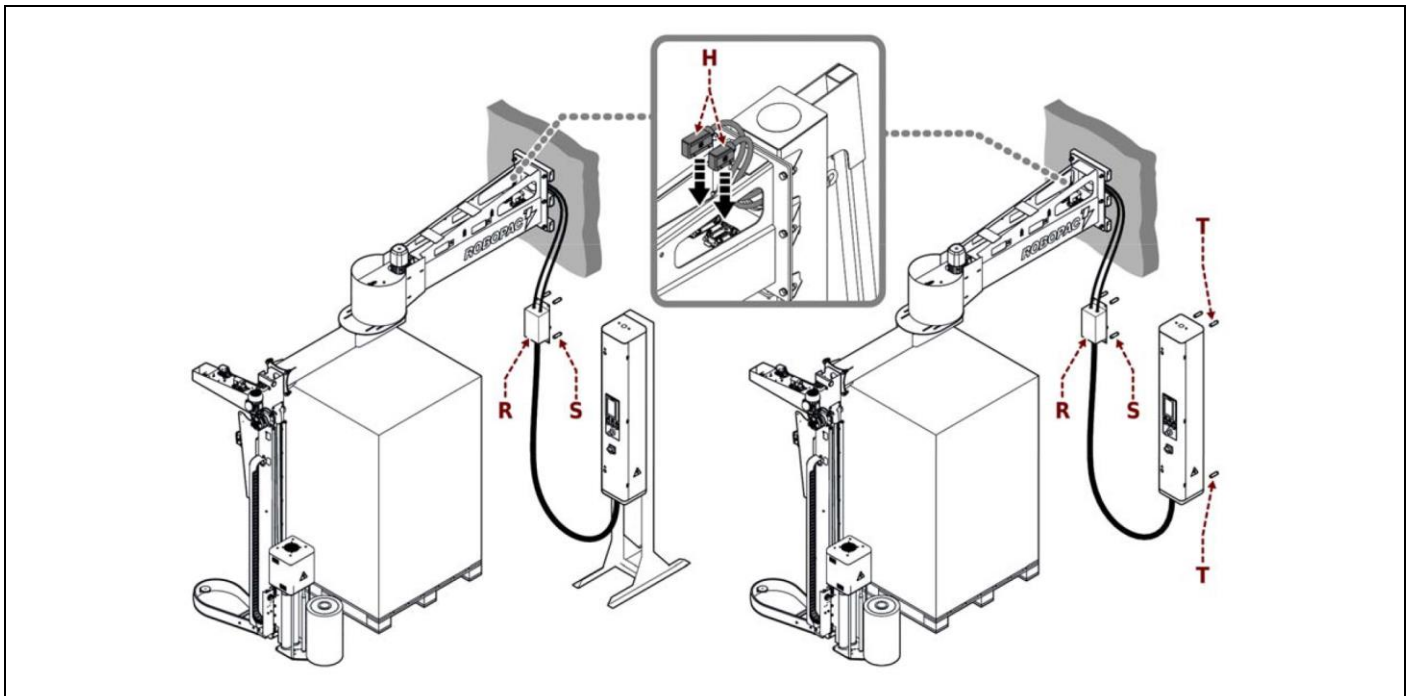

#### 4.4.3. INSTALLATION OF CW AUTOMATIC CUTTING AND SEALING SYSTEM (OPTIONAL)

1. Fix the clamp support (A), the angle bracket (B) and the sealing-cutting unit (C) with each other.
2. Position the resulting assembly according to the shown diagram.



**Danger - warning**

Rest the sealing device against the RH side of the column.

Depending on the maximum size of the wrappable product, align the indicator on the sealing device with the base front edge.

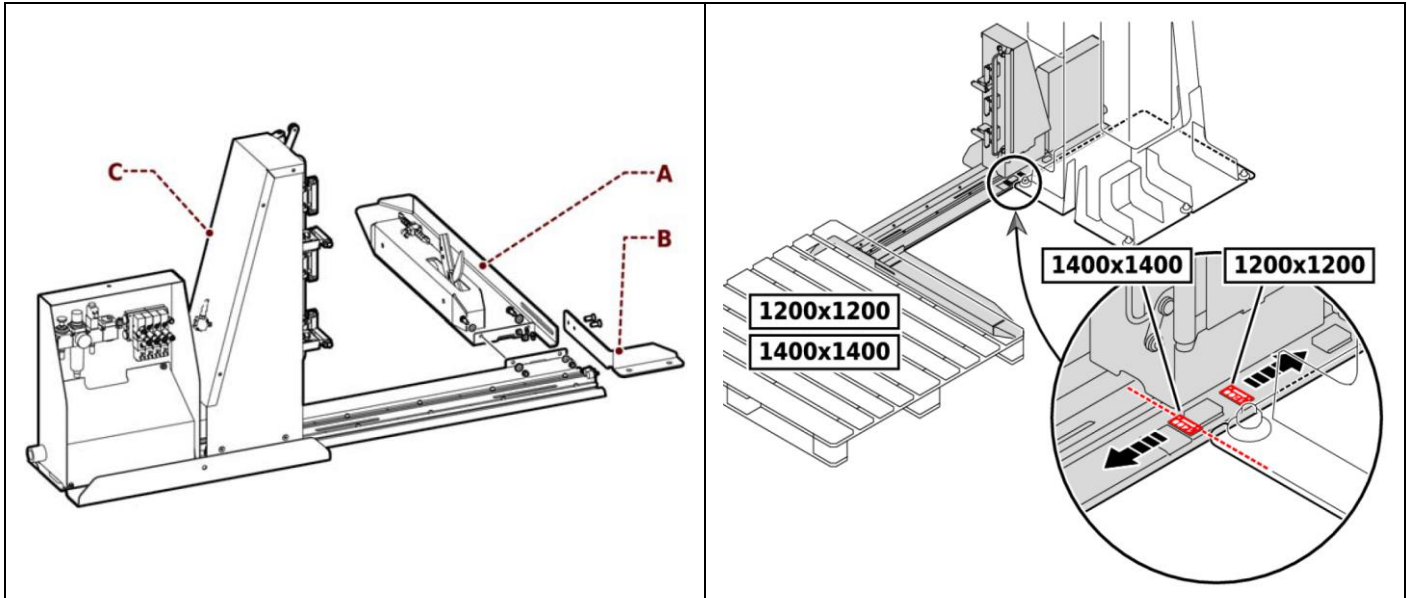

3. Fix the components to the ground by means of plugs (D).
4. Fix the additional electric control board (E) to the column by means of the supplied screws.

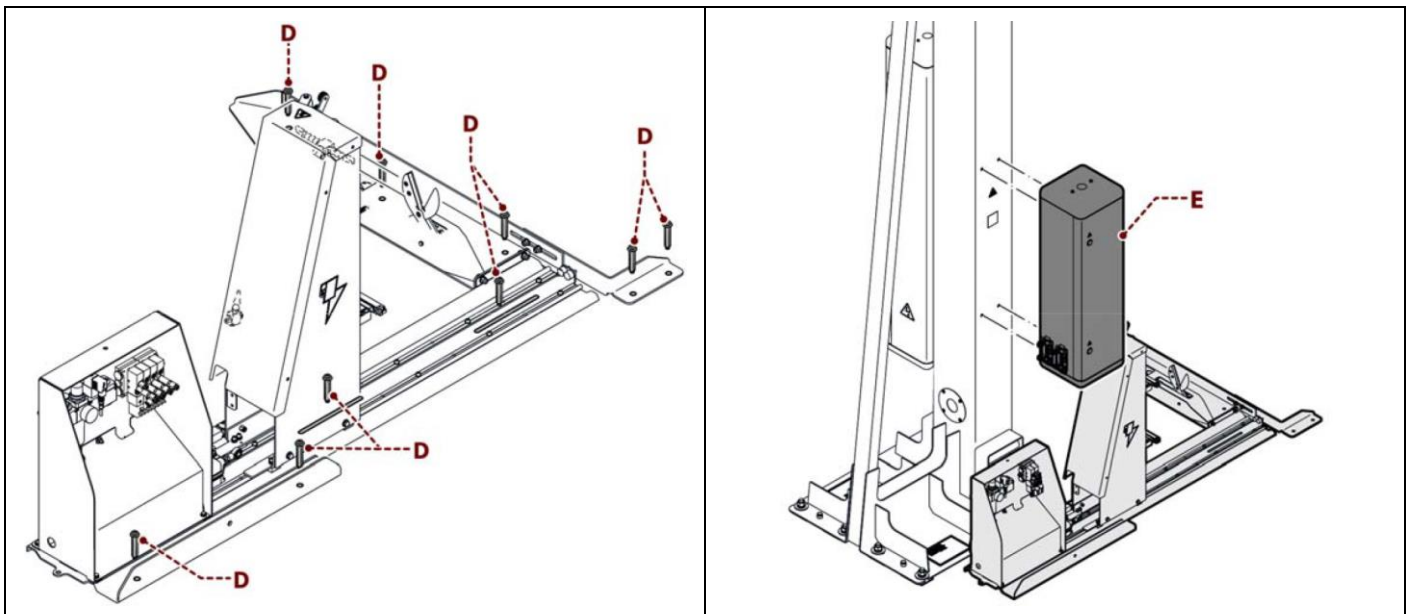

5. Connect the plug (F) from the machine electric control board to the socket on the additional electric control board.
6. Connect the plug (G) from the sealing-cutting unit to the socket on the additional electric control board.

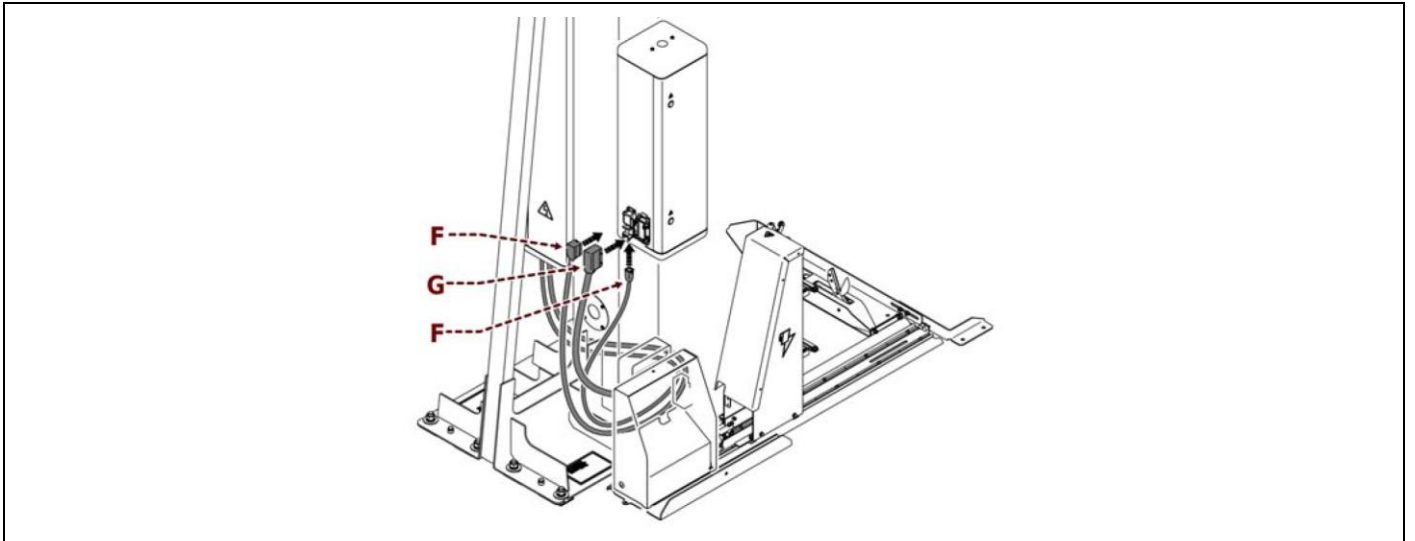

#### 4.4.4. INSTALLATION OF CS AUTOMATIC CUTTING AND SPREADING SYSTEM (OPTIONAL)

1. Fix the clamp support (A), the angle bracket (B) and the sealing-cutting unit (C) with each other.
2. Position the resulting assembly according to the shown diagram.



**Danger - warning**

Rest the sealing device against the RH side of the column.

Depending on the maximum size of the wrappable product, align the indicator on the sealing device with the base front edge.

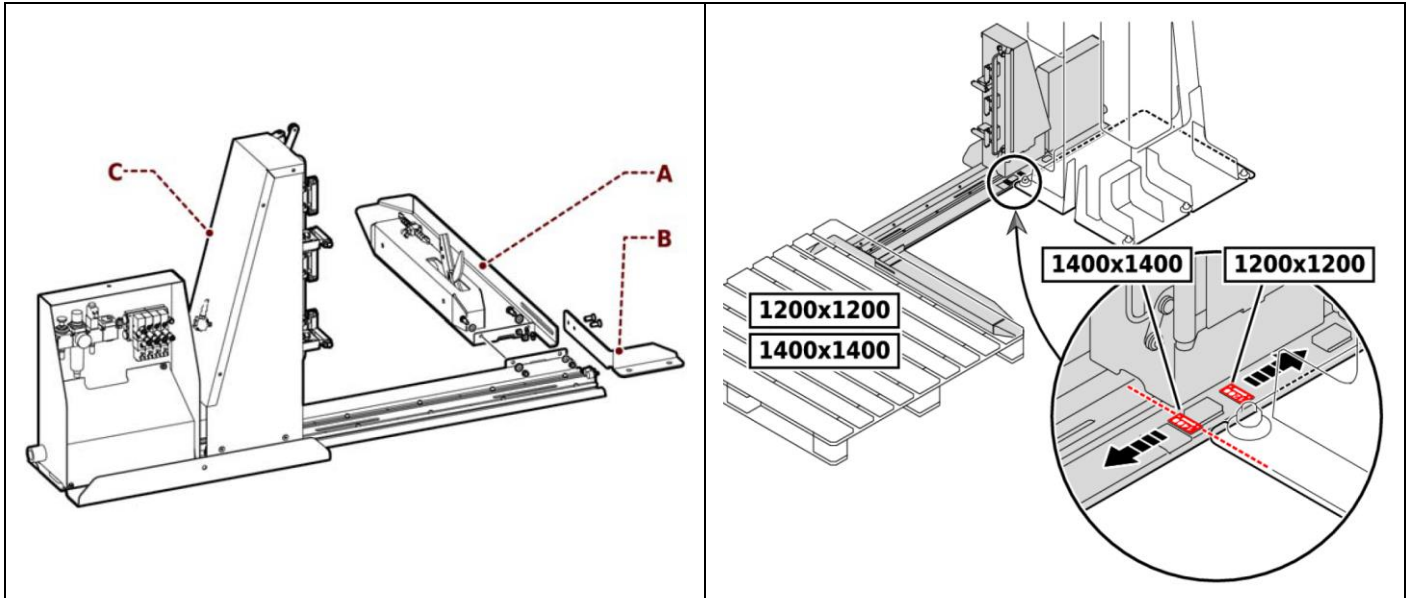

3. Fix the components to the ground by means of plugs (D).
4. Fix the additional electric control board (E) to the column by means of the supplied screws.

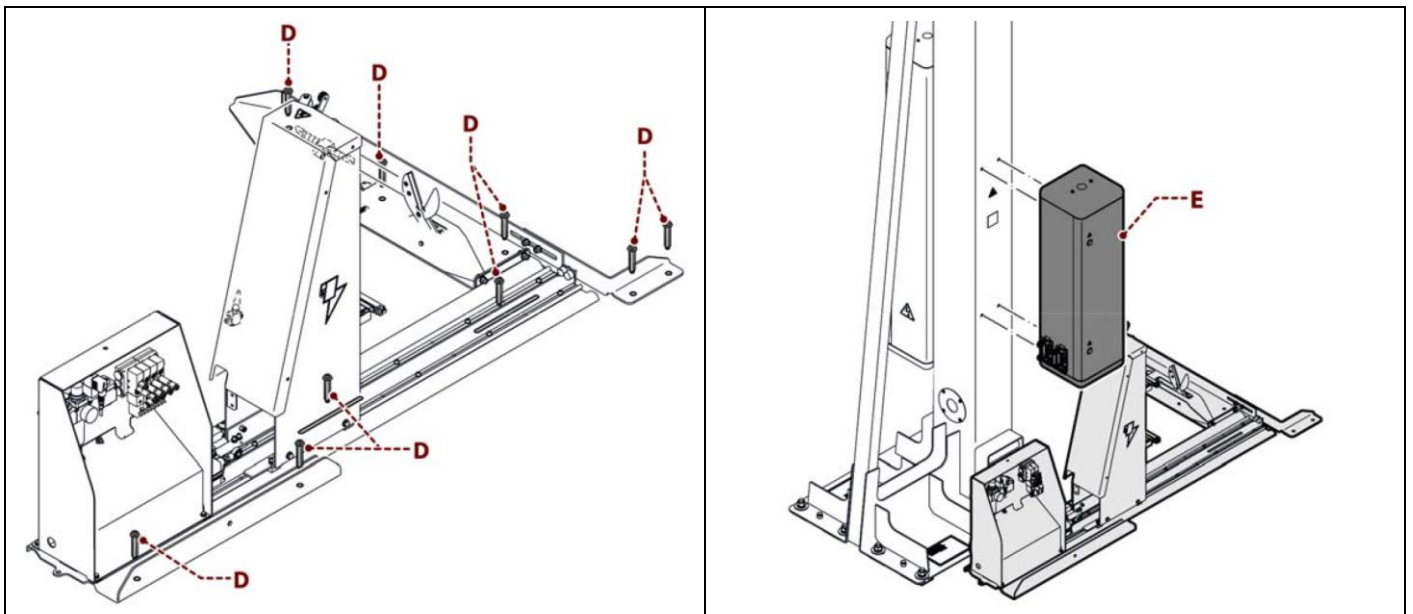

5. Connect the plug (F) from the machine electric control board to the socket on the additional electric control board.
6. Connect the plug (G) from the sealing-cutting unit to the socket on the additional electric control board.

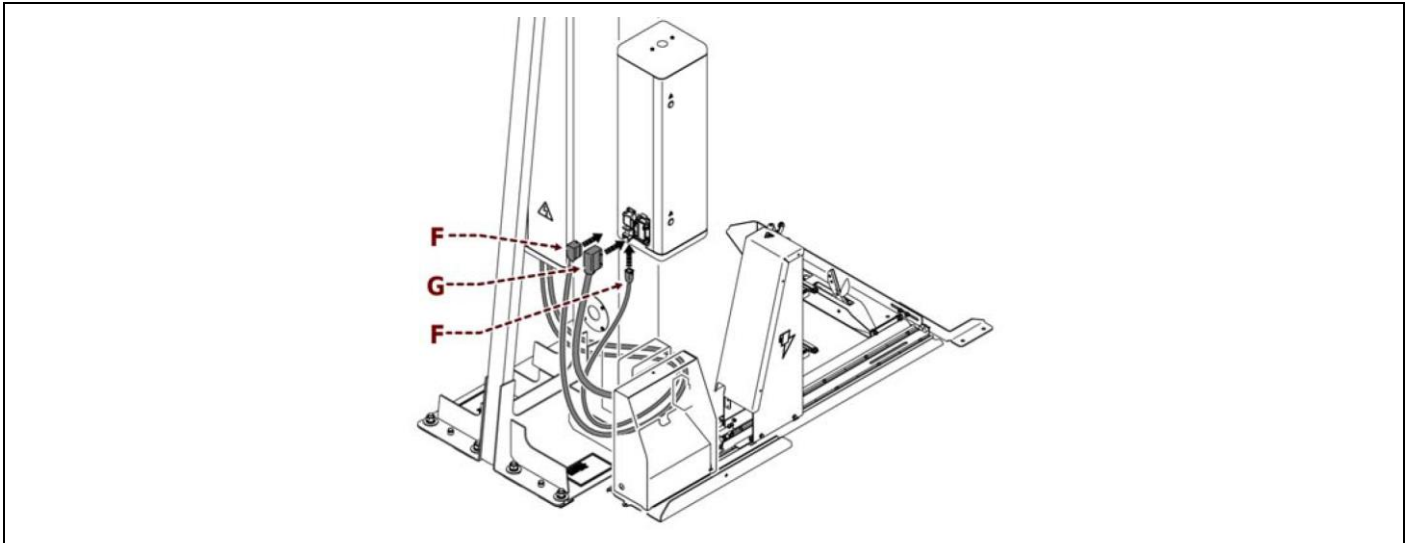

#### 4.5. RECOMMENDATIONS FOR CONNECTIONS



##### Important

The connections must be made in accordance with the specifications supplied by the Manufacturer in the enclosed diagrams. The person authorised to carry out said operation must have the skills and experience acquired and acknowledged in the specific sector, must perform the connection in accordance with the best practice and take into account all the regulatory and legislative requirements. Once the connection has been completed, before commissioning the machinery, it is necessary to perform an overall check to verify if said requirements have been complied with.

#### 4.6. PNEUMATIC CONNECTION (ONLY FOR ROTOTECH)

1. Insert a flexible hose in the end of the hose barb fitting and fasten it with a metallic screw clamp (A).
  2. Check that the valve (B) is in the "OPEN" position.
  3. Activate the supply line pressure.
  4. Check that the pressure gauge indicates at least **6 bar** and use the knob (C) to compensate any pressure difference.
- Repeat this operation when the machine is running.

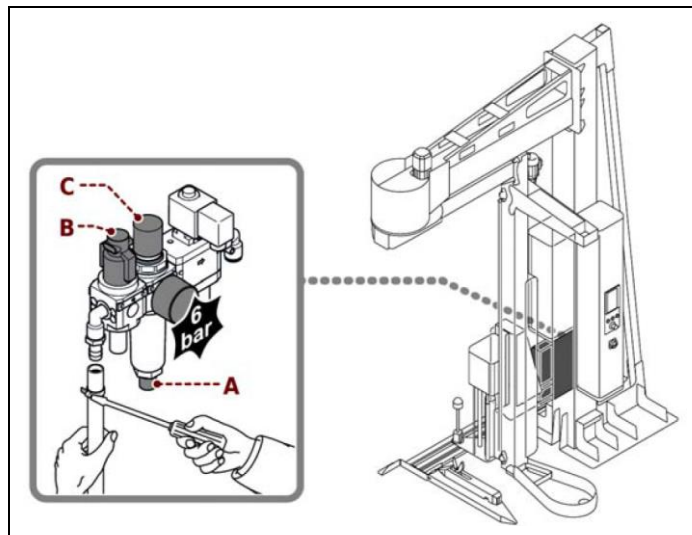

## 4.7. ELECTRICAL CONNECTION

Proceed as follows for the electrical connection.

1. Check that the line voltage (V) and frequency (Hz) correspond to those of the machine (See identification plate and wiring diagram).
2. Turn main switch to pos. **0 (OFF)**.
3. Connect the power cable to the socket (A), as shown in the figure, in accordance with the mains supply.
4. The earth wire (yellow-green) must be connected to its earth terminal **PE**.
5. Power the machine using the main switch.
6. Press the “Reset” button.
7. When the “Start” button is pressed, the plate should turn anticlockwise.

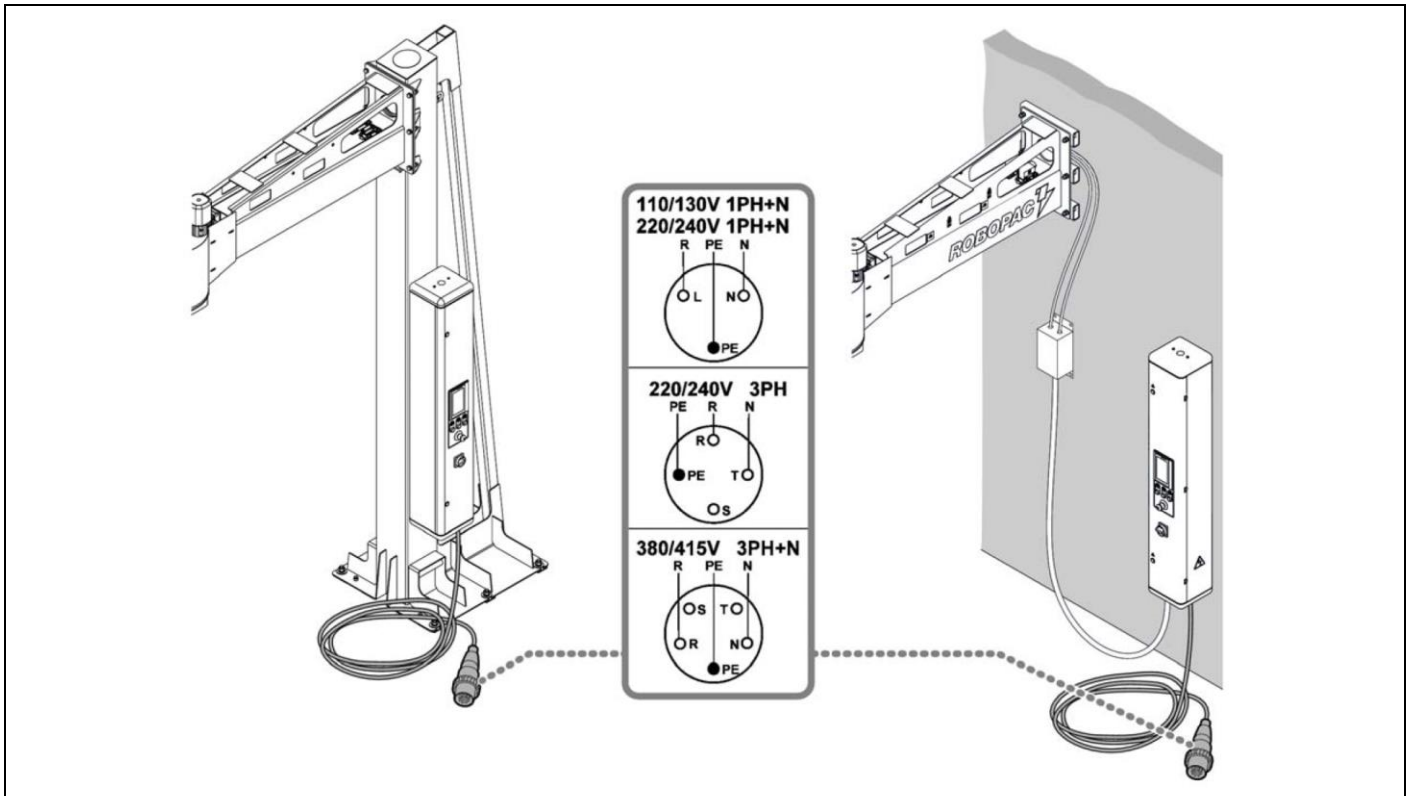

## 5. INFORMATION ON ADJUSTMENTS

### 5.1. RECOMMENDATIONS FOR ADJUSTMENTS

- Before performing any operation, the authorised operator must make sure to have understood the "Instructions for use".
- Activate all the safety devices provided, stop the machine and assess whether there is any residual energy before carrying out the operations.
- Provide suitable safety conditions in compliance with the regulations on workplace safety to prevent and minimise the risks.
- Pay attention to the safety warnings, do not misuse the machine and assess the possible residual risks.

## 5.2. "FILM STRETCH" ADJUSTMENT

### 5.2.1. SPOOL CARRIAGES OF "PDS" TYPE (PRE-STRETCH GEAR REPLACEMENT)

1. Stop the machine in safety conditions.
2. Remove the guard (A).
3. Slacken the belt (C) using the tensioner (B).
4. Slide the belt out of the pulley (D).
5. Loosen the screws (E).
6. Remove the plate (F) with motor and bearings.

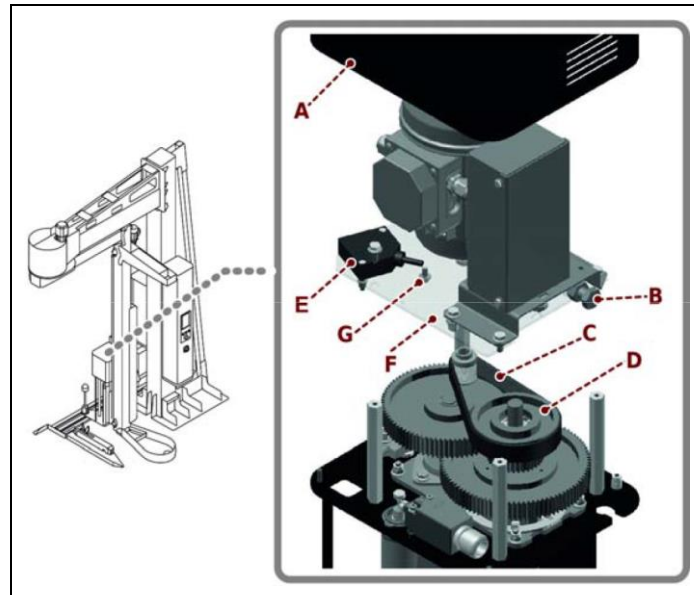

7. Remove the retaining ring (G).
8. Remove the pulley (D).
9. Remove the retaining ring (H).
10. Remove the gear (L).
11. Remove the retaining ring (M).
12. Remove the gear (N).
13. Loosen the screws and remove the disc (P) from the gear (N).
14. Select the set of gears (L-N) relating to the concerned pre-stretch rate (see table).

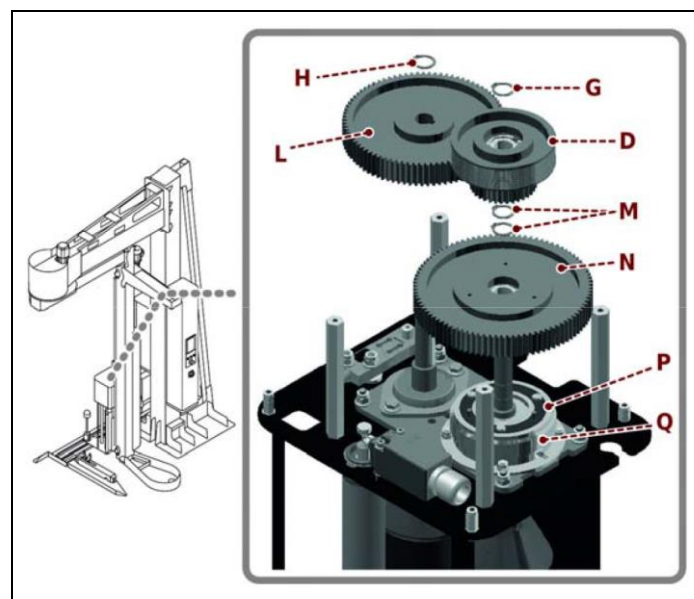

The table indicates the pre-stretch values which can be obtained with the relevant transmission gear set.



**Important**

Set the pre-stretch according to the film resistance and quality in order to obtain a low consumption.

Pre-stretch percentage	Gear code (L)	No. of gear teeth (L)	Gear code (N)	No. of gear teeth (N)
150%	2540300068	34	2540300070	85
200%	2540300003	29	2540300002	90
250%	2540300165	25	2540300164	94
300%	2540300027	24	2540300028	95

15. Fit the disc (P) and correctly fasten it to the gear (N) of the new transmission ratio.
16. Fit the gear (N) of the new transmission gear set.
17. Position the gear with the disc side (P) coupled with the clutch (Q).
18. Fit the retaining ring (M).
19. Fit the gear (L) of the new transmission gear set.
20. Fit the retaining ring (H).
21. Fit the pulley (D).
22. Fit the retaining ring (G).



**Important**

During reassembly, make sure that coupling tabs are correctly engaged.

23. Rest the plate (F) on the stud bolts, paying attention to fit the belt (C) on the pulley (D).
24. Tighten the screws (E).
25. Tension the belt (C) using the tensioner (B).
26. Manually turn the pre-stretching rollers in both directions to correctly seat the coupling between belt and pulleys.
27. Check the belt tensioning again and properly adjust it if necessary.
28. Refit the guard (A) when finished.

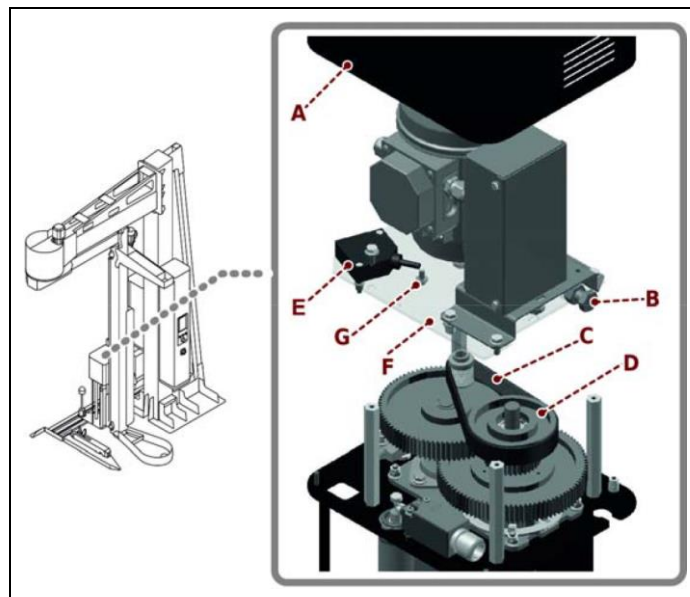

### 5.2.2. SPOOL CARRIAGES OF "FR for mesh" TYPE

1. Work on the handwheel (C) until reaching the desired film tensioning.

The brake shaft for mesh is an accessory that can be mounted on the carriage later on. This optional fitting allows the system to use a mesh reel with an "FR" std carriage.



**Important**

Adjust the reel-holder axis braking with the handwheel (C), enough to avoid the rotation by inertia of the mesh reel when unwinding during machine operation.

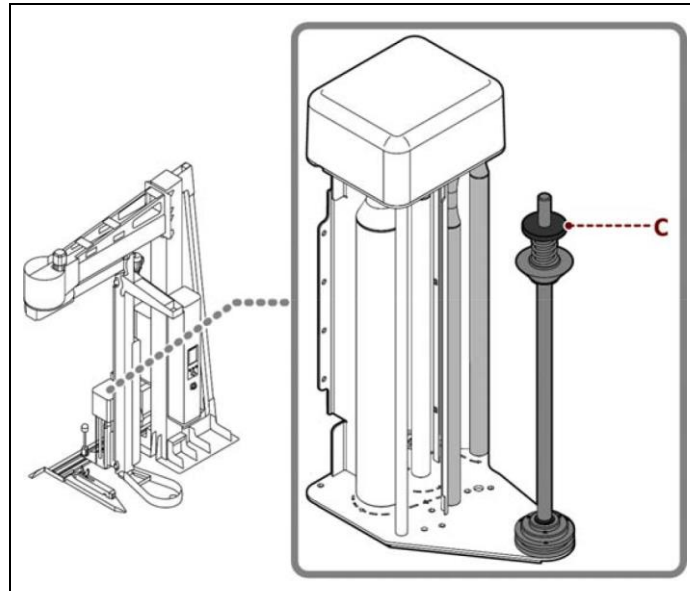

### 5.3. CLAMP CLOSING ADJUSTMENT

Adjust the opening of the flow regulator of the clamp control solenoid valve (please refer to "Pneumatic diagram") in order for its closing time to be between 1-2 seconds.

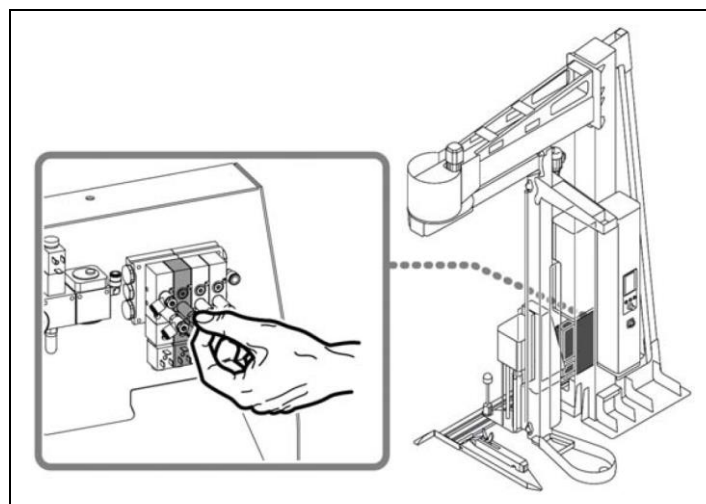

#### 5.4. SEALING/SPREADING DEVICE ADVANCE ADJUSTMENT

Adjust the opening of the flow regulators of the sealing-cutting solenoid valve:

- Open completely the regulator that controls the backward movement of the unit.
- Open slightly the regulator that controls the forward movement of the unit.

Please refer to the “Pneumatic diagram”.

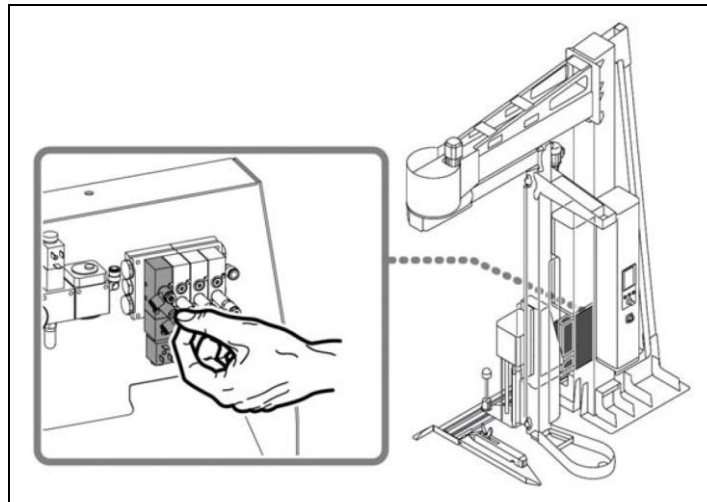

#### 5.5. AIR FLOW ADJUSTMENT

Adjust the opening of the flow regulators.

- Open as much as possible the regulators that control the air outflow from the nozzles for turning over the clamp-side film and collecting the film end.

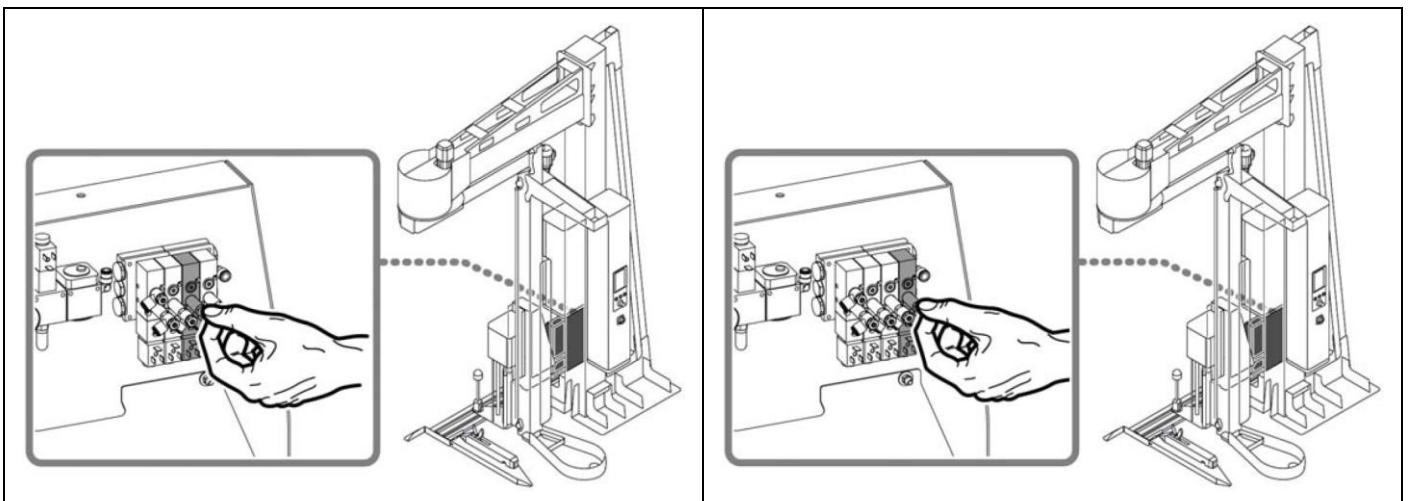

## 6. INFORMATION ABOUT THE USE

### 6.1. RECOMMENDATIONS FOR OPERATION AND USE

- When using the machine for the first time, the operator must read the manual and identify the control functions and simulate some operations, especially machine start and stop.
- Make sure that all safety devices are properly installed and efficient.
- Only carry out the operations foreseen by the Manufacturer and do not tamper with any device to obtain different performance levels.



#### Important

The frequency of the accidents derived from machine use depends on many factors that cannot always be foreseen and controlled.

Some accidents may be caused by unpredictable environmental factors, others are mainly due to users' behaviours.

On first use, and if required, in addition to being authorised and appropriately informed, the personnel must simulate some manoeuvres to identify the main controls and functions.

Only carry out the operations foreseen by the Manufacturer and do not tamper with any device to obtain different performance levels.

Make sure the safety devices are properly installed and efficient before use.

Users, besides complying with these requirements, must apply all the safety regulations and carefully read the descriptions of the controls and commissioning.

### 6.2. DESCRIPTION OF THE CONTROLS

- 1) **Emergency stop button:**  
it is used in case of imminent risk to stop, with a voluntary action, the machine parts which may pose a risk.  
For further details, see the paragraph "description of safety devices".
- 2) **User interface:**  
it is used to set or modify the machine operating parameters.  
For more details, see the paragraph "Description of user interface".
- 3) **"Cycle start" button:**  
it is used to start the wrapping automatic cycle.
- 4) **"Cycle stop" button:**  
it is used to stop the wrapping automatic cycle.
- 5) **"Reset" button:**  
it is used to reset the machine before restarting it after an emergency stop or after a shut-down due to the disconnection of the power supply.

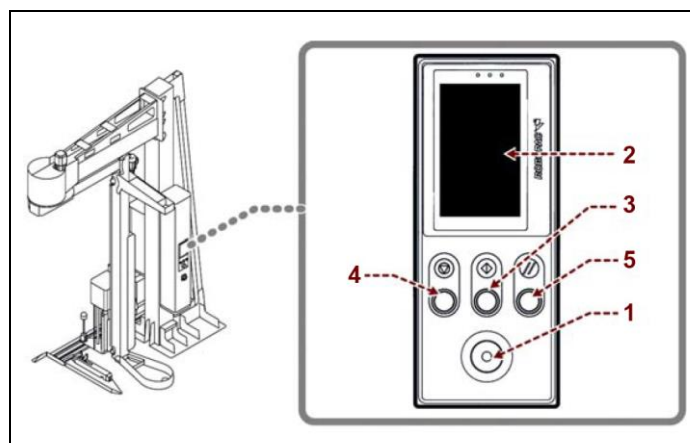

### 6.3. DESCRIPTION OF USER INTERFACE

The user interface is equipped with an active matrix “touch screen” colour display. To view the different functions, just “touch with a finger” the display areas.

The figure shows the functional logic diagram of the “navigation” modes. There is a control for the automatic packaging cycle: STANDARD CONTROL.

No.	Name	Description of the function
1	“Home” page	The page is displayed upon the activation of the reset control. The page displays the wrapping values currently in use and gives access the other pages.
1.1	“Layer home” page	The page is displayed upon the activation of the key on the RH side of the different recipes from the “recipe” page. The page displays the wrapping values currently in use and gives access the other pages.
2	“Manual handling” page	The page displays the controls to activate the handling of functions in “manual mode”.
3 – 3.1	“RECIPES” page	The page displays the controls to activate the concerned recipe.
4	“Wrapping cycle” page	The page displays the controls to activate the wrapping cycle
5	“General parameters” page	The page displays the controls to program the machine set-up parameters
6	“Production counters (pallets)” page	The page displays the controls to check the quantity (partial and total) of the pallets made
7	“(H.M.I.) enabling” page	The page displays the controls to customise the user interface operating mode
8	“Change password” page	The page displays the controls to change the password to access protected functions
9	“Enter password (user login)” page	The page displays the controls to enter the password (relating to the selected user) to access the protected functions.
10	“Service” page	The page is reserved to the Manufacturer’s Assistance Service only, to perform diagnostics and basic programming.

For details on the listed pages, see the description in the specific paragraph.

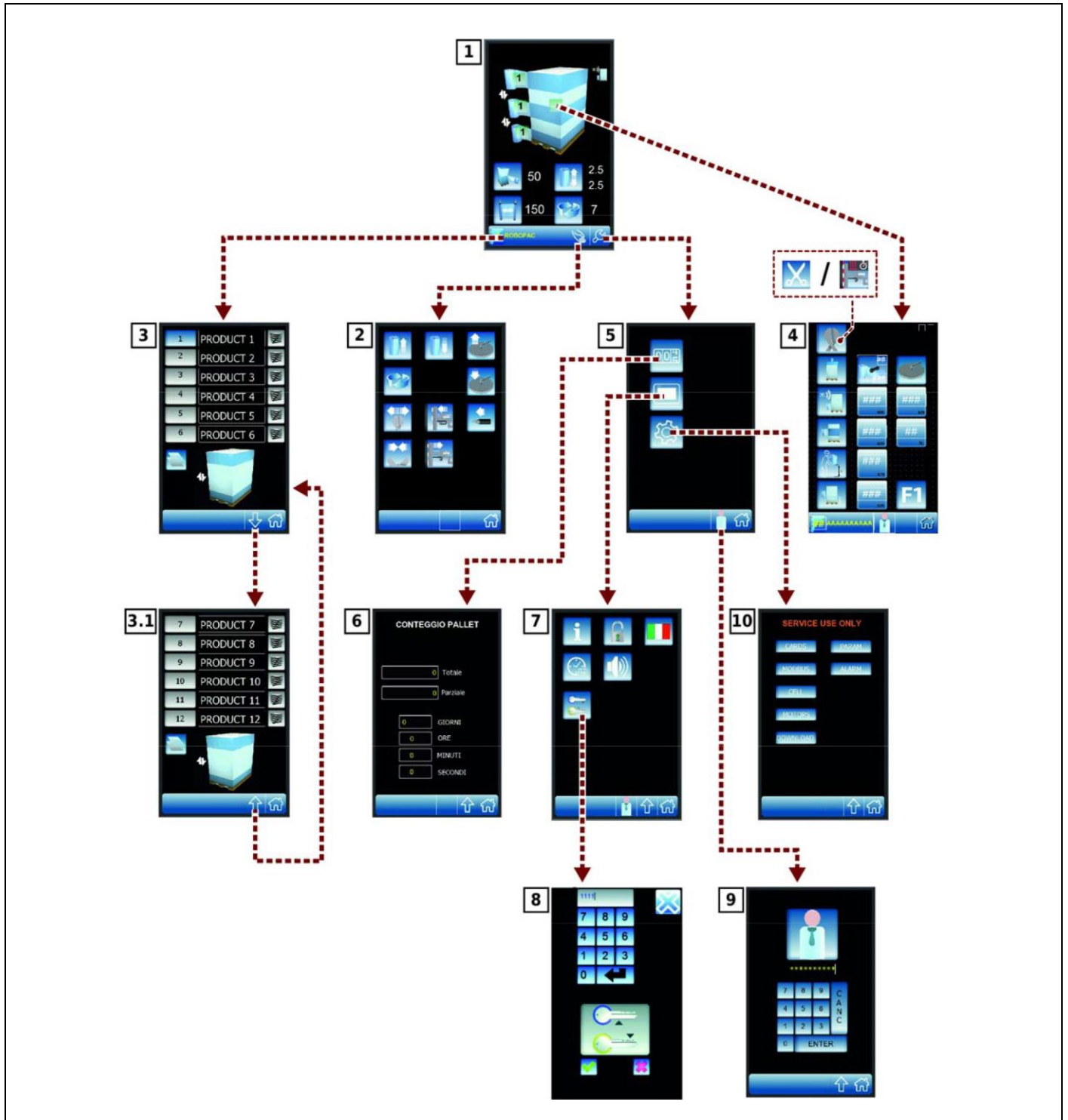

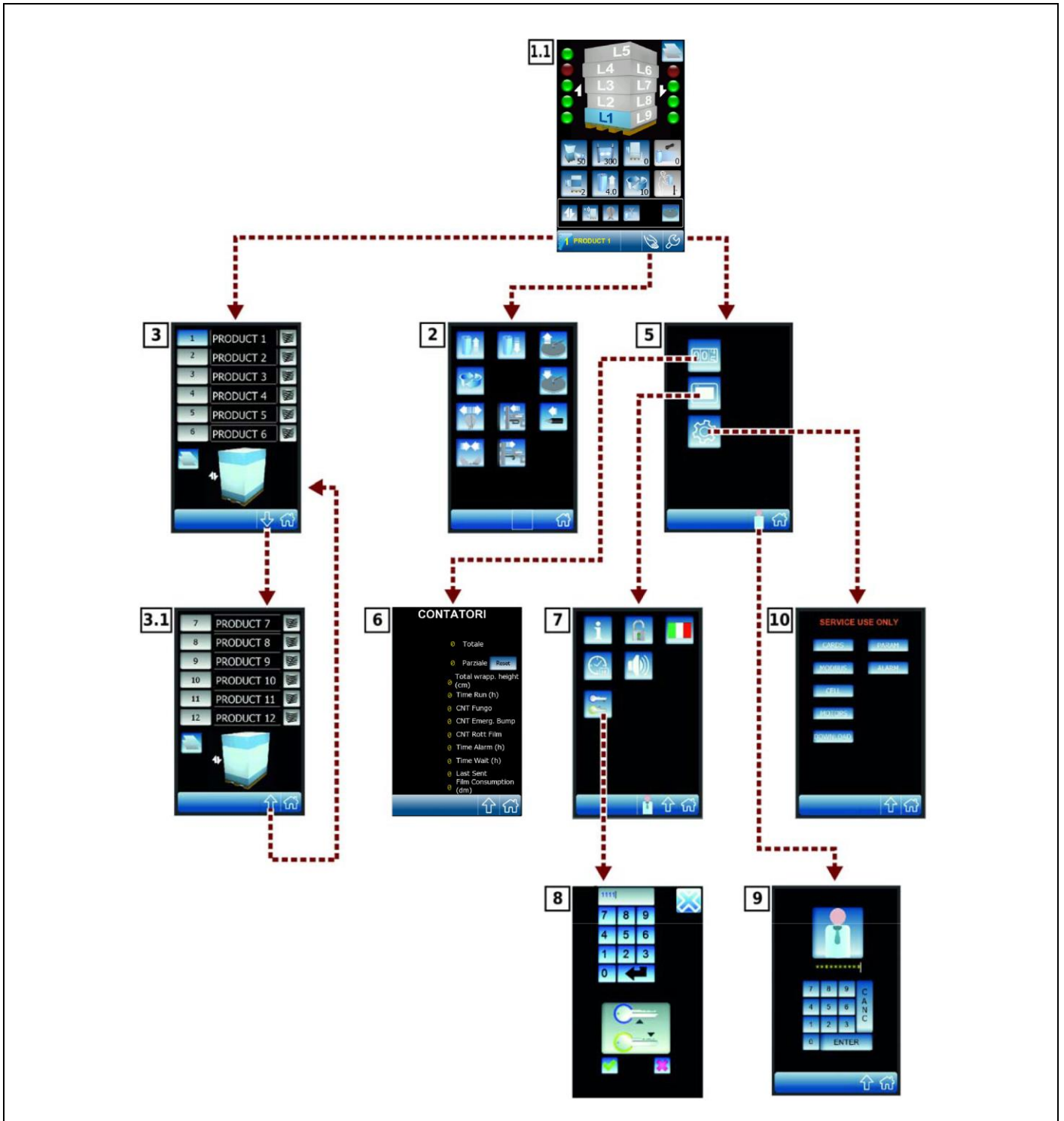

### 6.3.1. NUMERICAL AND ALPHANUMERICAL KEYBOARD

Some values, displayed in the areas of each single page, can be properly programmed. The keyboard is displayed each time that an editable or programmable area is pressed. After entering the characters (numerical or alphabetical), press the button to confirm. The new value will appear in the selected area.

No.	Name	Description of the function
A	Display area	The area displays the numerical and alphabetical characters entered
B	Button	Activating the control will close the page and the values entered will not be saved.
C	Button	Activating the control will delete the selected character
D	Button	Activating the control will delete one character at a time (starting from the last one on the right).
E	Button	Activating the control will save the value or the text entered
F	Button	Activating the control will perform the functions of the "space bar"

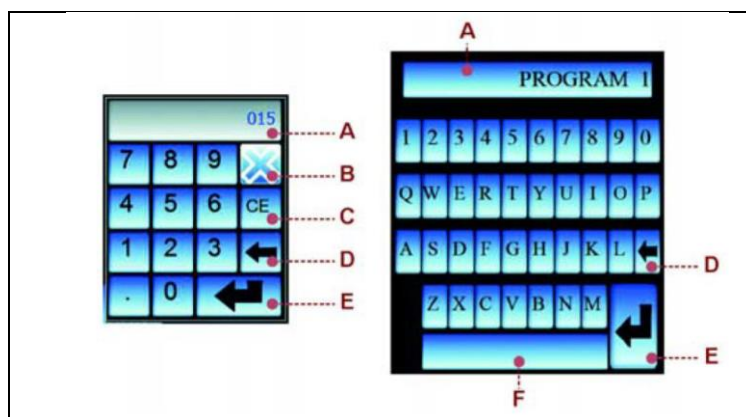

### 6.3.2. PROGRAMMING WINDOW

The window is displayed each time that an editable or programmable area is pressed.

A) Area: it displays the icon corresponding to the concerned parameter to be programmed.

The figure shows a typical example of window and the table includes the description of the icons.

Icon	Description of the function
1	Lower wrapping
2	Reinforcing wrapping
3	Upper wrapping
4	Film stretch
5	Film pre-stretch
6	Carriage upstroke speed
7	Carriage downstroke speed
8	Arm rotation speed
9	Cutting time
10	Sealing time
11	Roping device
12	Ergonomic upstroke

B) Button: it is used to close the programming window.

C) Bar: it is used to (quickly) increase or decrease the value displayed in the area (E).

D) Buttons: they are used to increase or decrease (one unit at a time) the value displayed in the area (E).

E) Area: it displays the programmed parameter value.

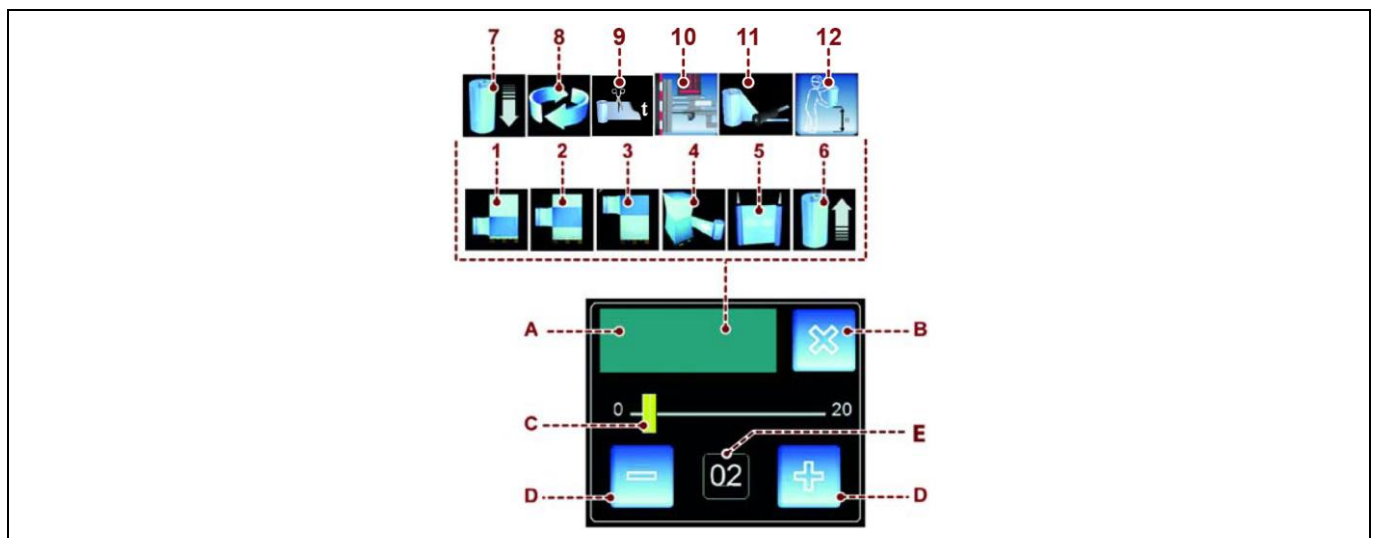

## 6.4. "HOME" PAGE



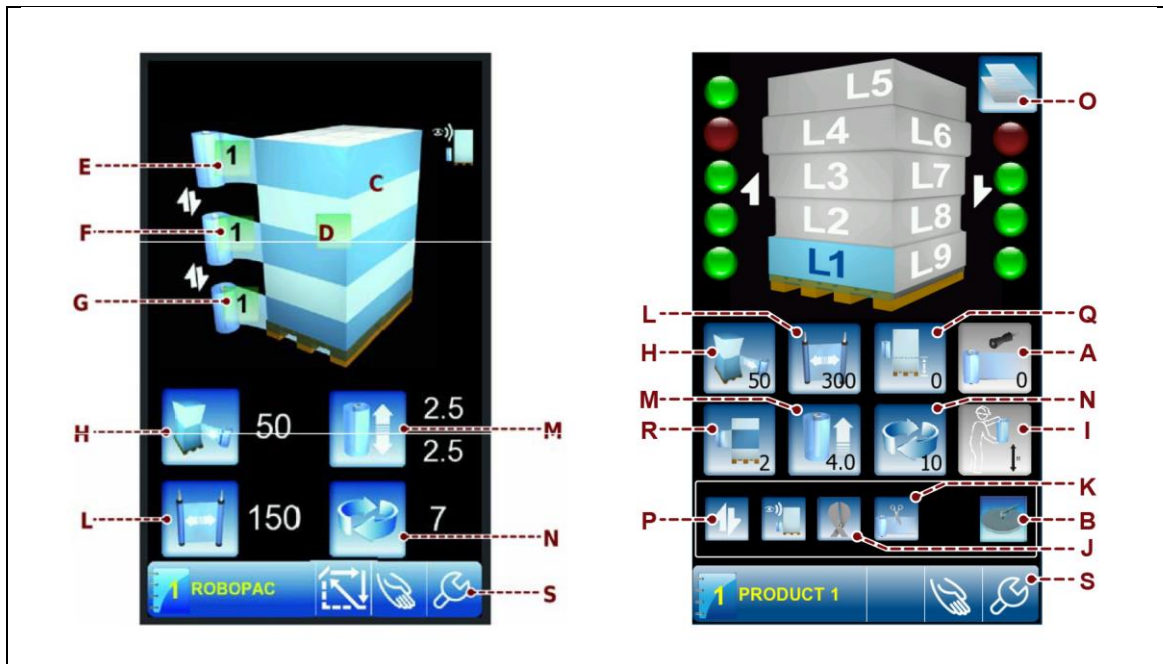

The page displays the wrapping values currently in use and gives access the other pages.



- A) **Button:**  
it is used to enable the roping device operation.
- B) **Button:**  
it is used to enable the presser operation.
- C) **Area:**  
it displays the preview of the selected pallet wrapping cycle.
- D) **Button:**  
it is used to display the "wrapping cycle" page.
- E) **Button:**  
it is used to program the number of wrappings in the upper end of the pallet.  
The displayed number indicates the programmed value.
- F) **Button:**  
it is used to program the number of reinforcing wrappings in the intermediate area of the pallet.  
The displayed number indicates the programmed value.
- G) **Button:**  
it is used to program the number of wrappings at the base of the pallet.  
The displayed number indicates the programmed value.
- H) **Button:**  
it is used to program the film stretch value.  
The displayed number indicates the programmed value.
- I) **Button:**  
it is used to program the distance from ground (offset) where the film carriage must be positioned at the end of the wrapping cycle (ergonomic height).
- J) **Button:**  
it is used to enable and disable the clamping and cutting cycle.
- K) **Button:**  
it is used to program the cutting and sealing time.
- L) **Button:**  
it is used to program the film pre-stretch value (only for "PDS" - "PVS" carriages).  
The displayed number indicates the programmed value.
- M) **Button:**  
it is used to program the speed of the carriage vertical movement.  
The displayed number indicates the programmed value.

- N) **Button:**  
it is used to program the machine wrapping speed.  
The displayed number indicates the programmed value.
- O) **Button:**  
it is used to copy the data from one layer to another.
- P) **Wrapping cycle.**
- Q) **Distance from the ground at wrapping start.**
- R) **Reinforcing wrapping programming.**
- S) **Toolbar.**  
The toolbar is displayed in every page and features only the buttons which can be activated.

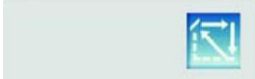
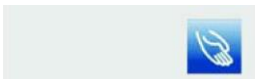
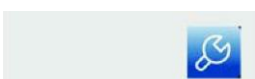
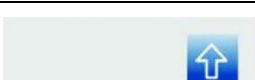
The list includes the description of the elements (buttons, icons, etc.) displayed in the area.

	<p><b>Button:</b> it is used to display the “recipes” page. The displayed number indicates the activated recipe.</p>
	<p><b>Area:</b> it displays the name of the active recipe.</p>
	<p><b>Button (jog):</b> it is used for machine reset; a mini-cycle resets the machine. At the end of the reset, the button is not displayed.</p>
	<p><b>Button:</b> it is used to display the “manual handling” page.</p>
	<p><b>Button:</b> it is used to display the “general parameters” page.</p>
	<p><b>Button:</b> it is used to display the upper level page.</p>
	<p><b>Button:</b> it is used to display the “home” page.</p>

## 6.5. "MANUAL HANDLING" PAGE

The page displays the controls to activate handling in "manual mode".

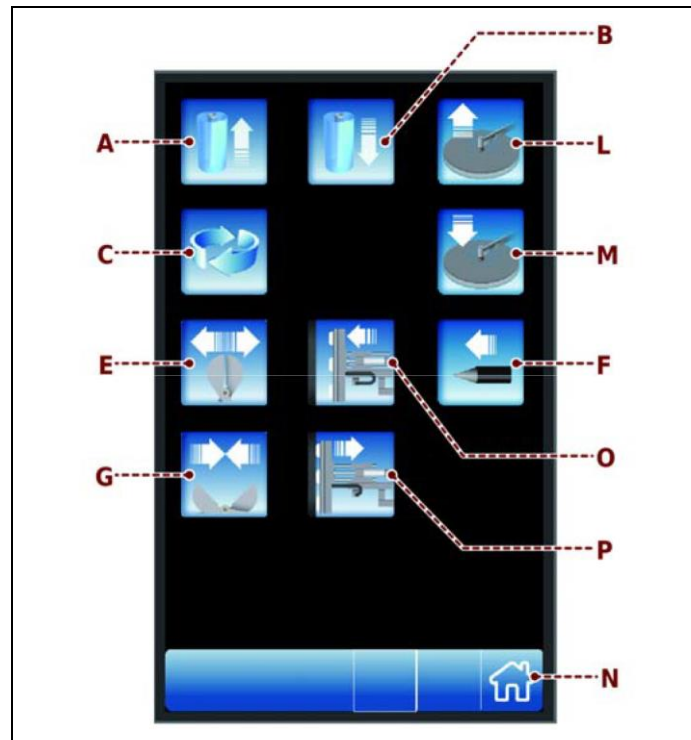

- A) **Button (hold to run):**  
it is used to activate the carriage upstroke.
- B) **Button (hold to run):**  
it is used to activate the carriage downstroke.
- C) **Button (hold to run):**  
it is used to activate the arm clockwise rotation.
- E) **Button (hold to run):**  
it is used to activate clamp opening.
- F) **Button (hold to run):**  
it is used to activate the punch forward movement.
- G) **Button (hold to run):**  
it is used to activate the clamp closing.
- L) **Button:**  
it is used to activate the presser upstroke.
- M) **Button:**  
it is used to activate the presser downstroke.
- N) **Button:**  
it is used to display the "home" page.
- O) **Button:**  
it is used to move forward the sealing-cutting unit (optional).
- P) **Button:**  
it is used to move backward the sealing-cutting unit (optional).

### 6.5.1. MANUAL REINFORCEMENT FUNCTION



**Important**

This function cannot be performed with layered recipes.

When performing a standard recipe, during the carriage upstroke or downstroke, after having performed the wrapping at the base of the pallet or at its upper end, it is possible to manually perform intermediate wrapping by pressing the button (A) with two different modes:

- Keep the button (A) pressed to stop the carriage performing reinforcement wrapping until the button is released.
- Repeatedly press the button (A) to make the carriage perform as many reinforcement wrapping turns as the times the button has been pressed (1+9 turns).

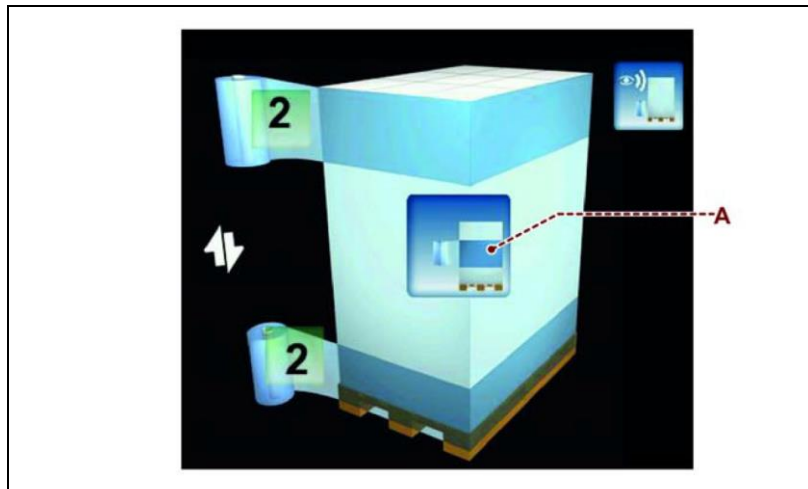

**Important**

The button is visible only during the machine automatic operation.

## 6.6. "RECIPES" PAGE

The page displays the controls to activate the concerned recipe.



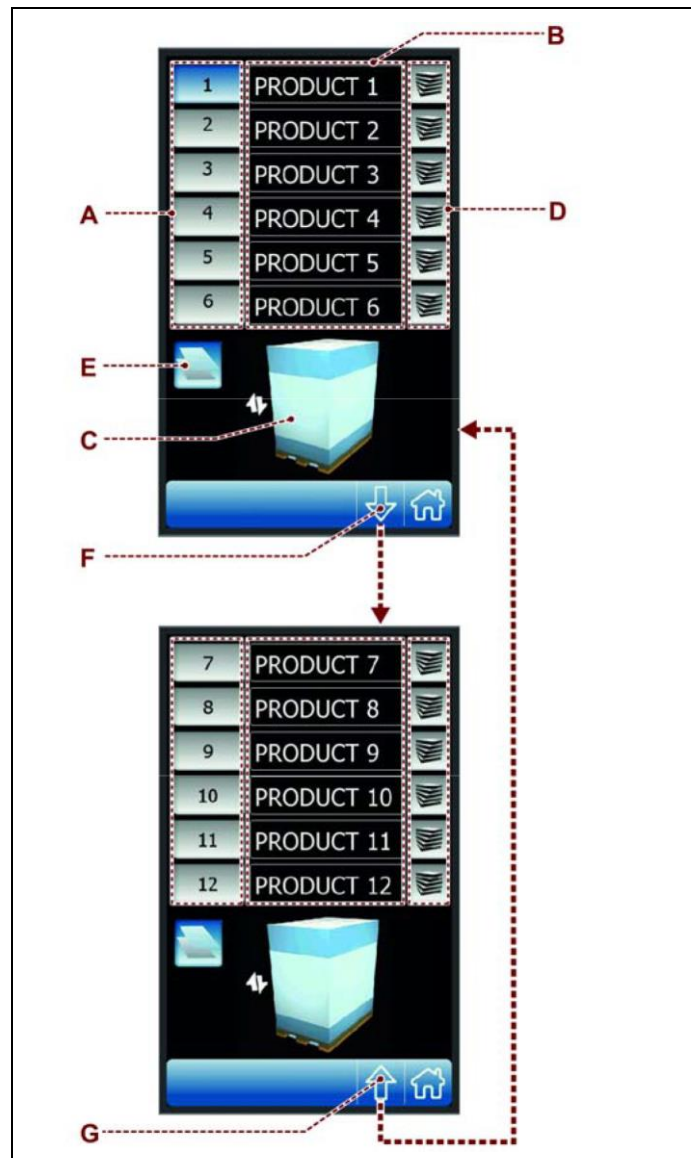











- A) **Buttons:**  
they are used to activate the desired recipe.  
Blue background: function enabled.
- B) **Buttons:**  
they are used to program the recipe name.
- C) **Area:**  
it displays the preview of the selected pallet wrapping cycle.
- D) **RH buttons:**  
they are used to activate the layered cycle.
- E) **Button:**  
it is used to copy the data from one recipe to the other.
- F) **Button:**  
it is used to display the next recipe page.
- G) **Button:**  
it is used to display the previous recipe page.



## 6.7. "WRAPPING CYCLE" PAGE

The page displays the controls to program the wrapping cycle.

At every activation, the button displays the enabled function with the reference icon.

	<p><b>A)</b> Area: it displays the recipe name and number.</p>
  	<p><b>C)</b> Button: it is used to select the type of pallet wrapping cycle.</p> <p>Icon <b>(C1)</b>: it is used to select the "single wrapping" cycle.</p> <p>Icon <b>(C2)</b>: it is used to select the "double wrapping" cycle.</p> <p>Icon <b>(C3)</b>: it is used to select the "double wrapping cycle with feeder".</p>
 	<p><b>D)</b> Button: it is used to select the stop modes (automatic or programmed) of film carriage during upstroke.</p> <p>Icon <b>(D1)</b>: it is used to select the automatic stop of the film carriage (upstroke phase) depending on the height of the pallet being wrapped.</p> <p>Icon <b>(D2)</b>: it is used to select the programmed stop of the film carriage (upstroke phase) depending on the height of the pallet.</p>
	<p>Enabling this button, (altimeter) will display another button next to button <b>(E)</b> to set the pallet height.</p> <p>To obtain a wrapping delay when this function is active, it is necessary to set a height greater than that of the product to be wrapped.</p> <p><b>E)</b> Button: it is used to program the delay of the stopping point of the film carriage during the upstroke phase (only with automatic stop).</p>
	<p><b>F)</b> Button: it is used to enable and disable the programming of the distance from the ground (offset) at the beginning of wrapping.</p> <ul style="list-style-type: none"> <li>- Blue background: Function enabled.</li> <li>- Grey background: Function disabled.</li> </ul>
	<p><b>G)</b> Buttons: they are used to program the distance from the ground (offset) for wrapping start. The button is only visible if the function was enabled through the button <b>(F)</b>.</p>
	<p><b>H)</b> Button: it is used to enable and disable the reinforcing wrapping programming mode.</p> <ul style="list-style-type: none"> <li>- Blue background: Function enabled.</li> <li>- Grey background: Function disabled.</li> </ul>
	<p><b>L)</b> Buttons: they are used to program the positioning value and the number of reinforcing wrappings. The buttons are visible only if the function has been enabled with the button <b>(H)</b>.</p>
  	<p><b>M)</b> Button: it is used to enable and disable the clamping and cutting cycle.</p> <p>Icon <b>(M1)</b>: it is used to adjust the film cutting time.</p> <p>Icon <b>(M2)</b>: it is used to access the sealing and cutting time setting page.</p>
	<p><b>N)</b> Button: it is used to enable the presser operation.</p>

	<p><b>O)</b> Button: it is used to program the distance from ground (offset) where the film carriage must be positioned at the end of the wrapping cycle (ergonomic height). The button is only visible if the function was enabled through the button (S).</p>
	<p><b>P)</b> Button: it is used to enable/disable the special cycles (optional).</p>
	<p><b>Q)</b> Buttons: they are used to enable, disable the creasing head and select the number of roping turns.</p>
	<p><b>R)</b> Button: it is used to program the height of the pallet to be wrapped.</p>
	<p><b>S)</b> Button: it is used to program the height where the carriage must stop at the end of the cycle.</p>

### 6.8. "GENERAL PARAMETERS" PAGE

The page is used to program the machine operating parameters.

- A) Button: it is used to display the "production counters (pallets)" page.
- B) Button: it is used to display the "H.M.I. settings" page.
- C) Button: it is used to display the "service" page.

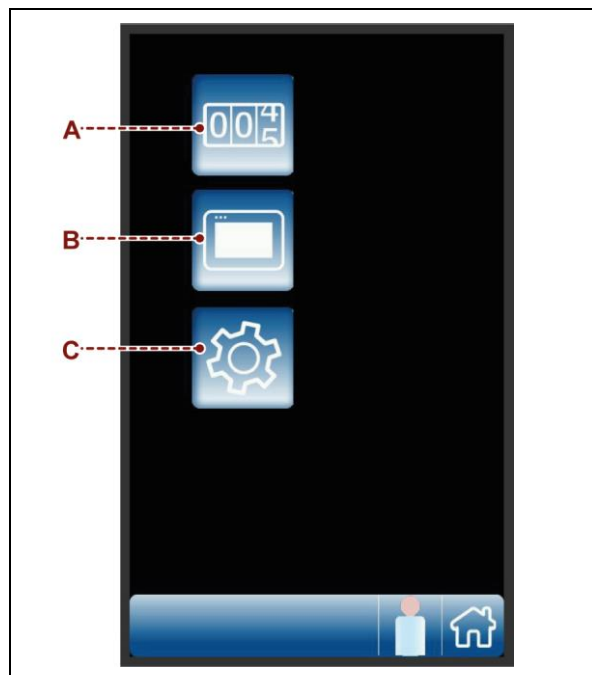

## 6.9. "PRODUCTION COUNTERS (PALLETES)" PAGE

The page displays the controls to check the quantity (partial and total) of the pallets made.

- A) Total Counter of Wrapping Cycles performed by the machine.
- B) Partial counter of the wrapping cycles performed by the machine.
- C) Total upstroke of the carriage in centimetres in the performed wrapping cycles.
- D) Working time of the machine expressed in hours.
- E) Counter of the emergency mushroom-head push-button activations during the working cycle.
- F) Counter of the emergency bumper activations during the working cycle
- G) Counter of film breakages during the working cycle.
- H) Time spent in alarm status (expressed in hours)
- I) Time spent by the machine in STOP status (expressed in hours)
- J) Value representing the last date an R-Connect package was shipped
- K) Film consumption during the working cycle of the machine expressed in decimetres.

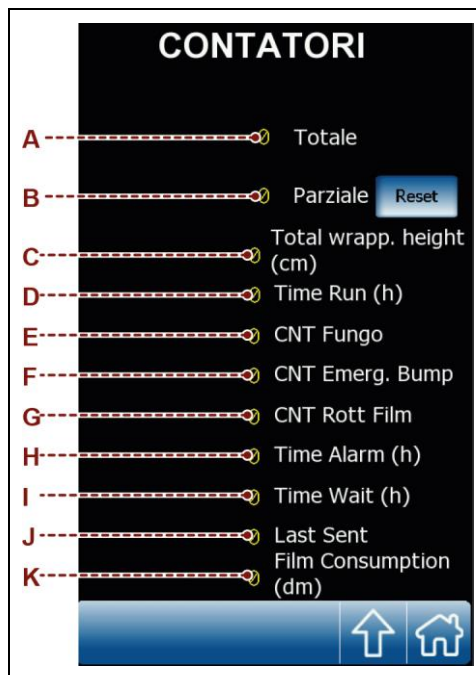

## 6.10. "HMI SETTINGS" PAGE

The page displays the controls to customise the user interface operating mode.

- A) Button: it is used to enable and disable the display acoustic signal.
- B) Button: it is used to display the "change password" page .
- C) Button: it is used to enable and disable the recipe programming mode.  
The function is active only if the system is accessed by a "machine operator" user (see the "enter password page (user login)".
- D) Button: it is used to display the page with the software version.
- E) Button: it is used to select the language.
- F) Button: it is used to display the page for setting date and time.

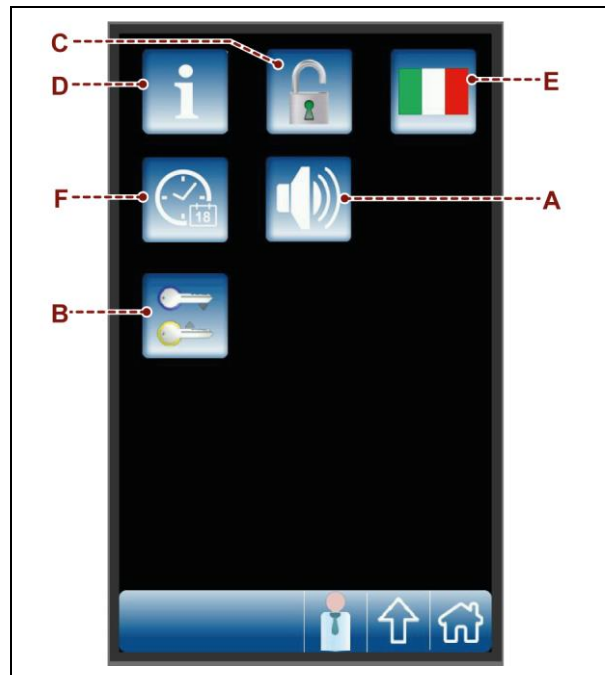

## 6.11. "PASSWORD CHANGE" SCREEN

The page displays the controls to change the password to access protected functions.

- A) Button: it is used to display the upper level page .
- B) Area: it displays the entered characters.
- C) Numerical keyboard.
- D) Button: it is used to confirm the entered values.  
The activation of the control is signalled by the animation of icon (G).
- E) Button: it is used to save the password.  
The control is enabled only if the animation of icon (G) is active.
- F) Button: it is used to reset the entered values.  
The activation of the control disables the animation of icon (G).

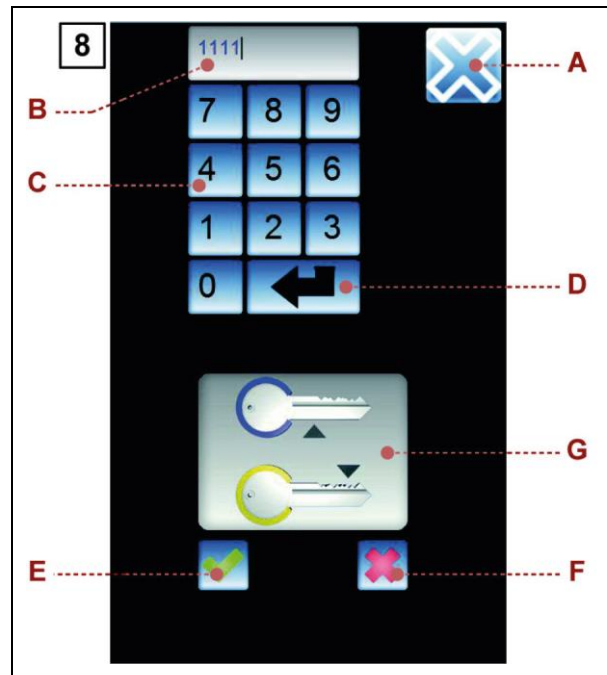

## 6.12. "ENTER PASSWORD" SCREEN (USER LOGIN)

The page displays the controls to enter the password (relating to the selected user) to access the protected functions.

**A)** Button: it is used to select the type of user concerned.

At every activation, the button displays the enabled function with the reference icon.

- Icon **(A1)**: it is used to select the "machine operator" user.
- Icon **(A2)**: it is used to select the "service support" user.
- Icon **(A3)**: it is used to select the "software administrator" user.

**B)** Area: it displays the entered characters.

**C)** Numerical keyboard.

**D)** Button: it is used to confirm the entered password (login).

To prevent another type of user from accessing the protected functions, use one of the following procedure to perform the "user logout" at the end of the operations.

- Touch the icon **(A1)** located in the toolbar.
- Switch the machine off and then on again.

**E)** Button: it is used to delete incorrect entered values.

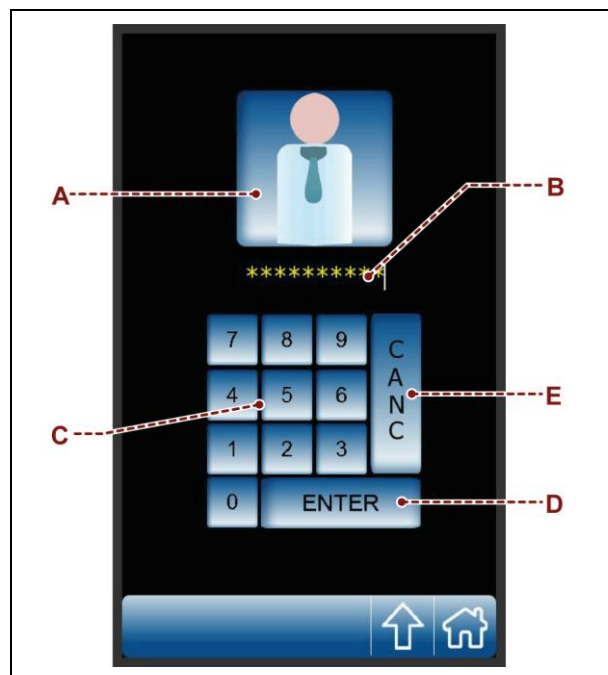

### 6.13. "SERVICE" SCREEN

The page is reserved to the Manufacturer's Service support only, to perform diagnostics and basic programming.

- A) Button: it is used to display the status of the various electronic components of the electric control panel.
- B) Button: it is used to display the **MODBUS** status.
- C) Button: it is used to display the load cell offset.
- D) Button: it is used to display the status of motors.
- E) Button: it is used to update the software.
- F) Button: it is used to display the machine set-up general parameters.
- G) Button: it is used to display the alarm log.

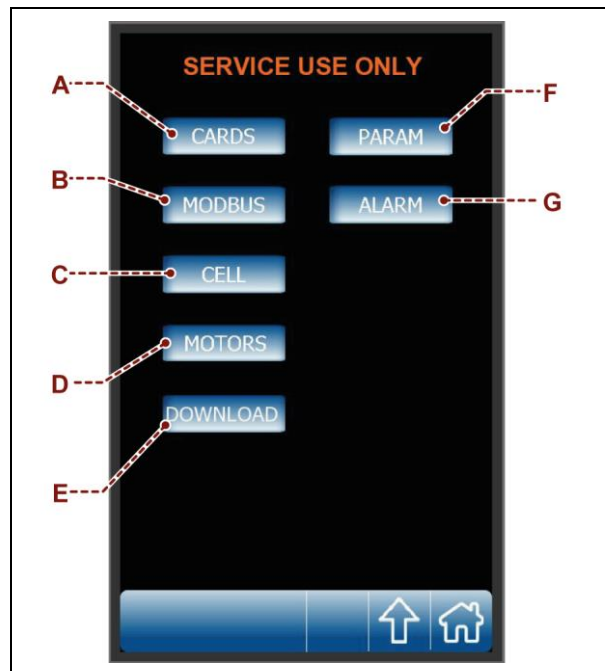

## 6.14. NEW RECIPE PROGRAMMING

1. Display the “home” page 1.
  2. Press the button (A) to display the “recipes” page 3.
  3. Press the button (F), corresponding to the required recipe, to access the “home” 1.1. page.
  4. If necessary, press the button (E) to copy the data from one recipe to another.
  5. Select the concerned recipe.
  6. Set the recipe name.
  7. Press the button (B) to display the “home” page 1.
  8. Press the button (C) to display the “wrapping cycle” page 4.
  9. Set the recipe parameters.
  10. Press the button (B) to display the “home” page 1.
- The area (D) displays the preview of the selected pallet wrapping cycle.

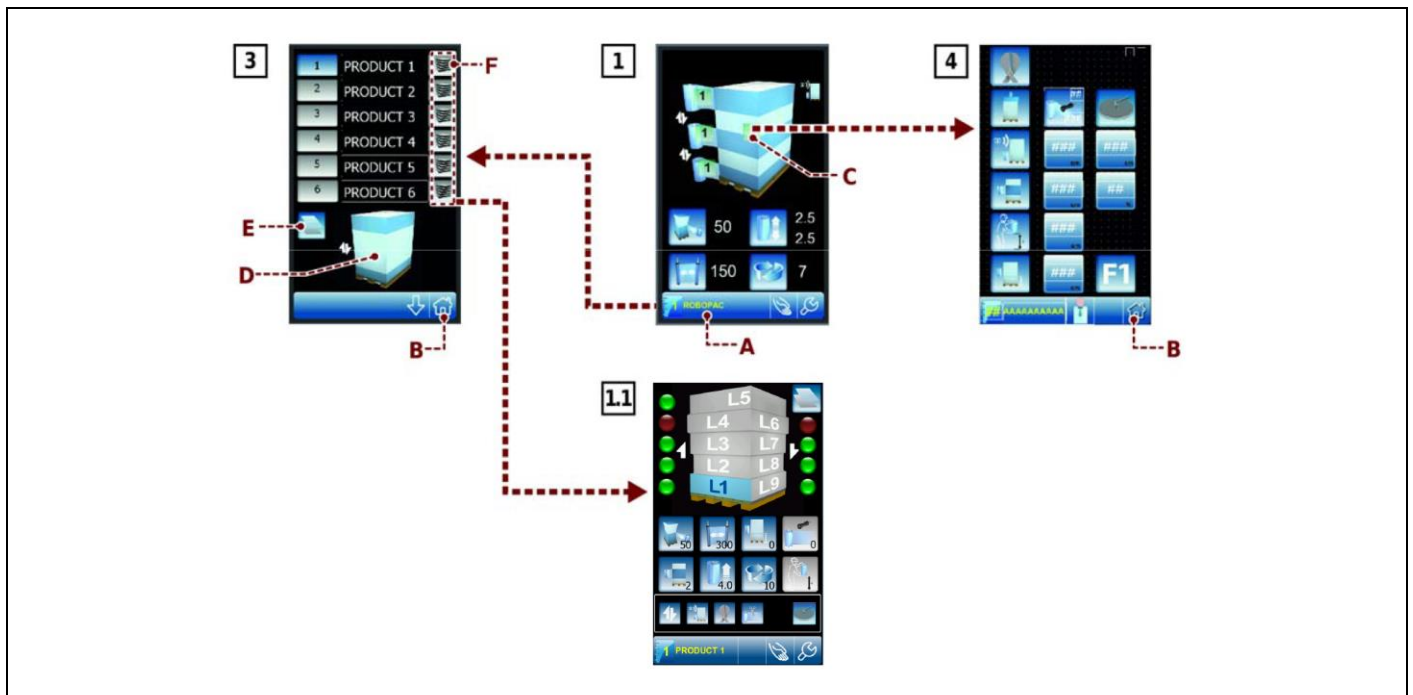

## 6.15.MACHINE SWITCHING ON AND OFF

1. Turn the main switch (A) to I (ON) to activate the power supply. The display shows "RES".
2. Press the "reset" button (B) when shown on the display.
3. Set the cycle parameters (See "Cycle parameters setting").
4. Perform the cycle starting operations (see "Cycle start and stop").
5. Turn the main switch (A) to 0 (OFF) to switch the machine off.

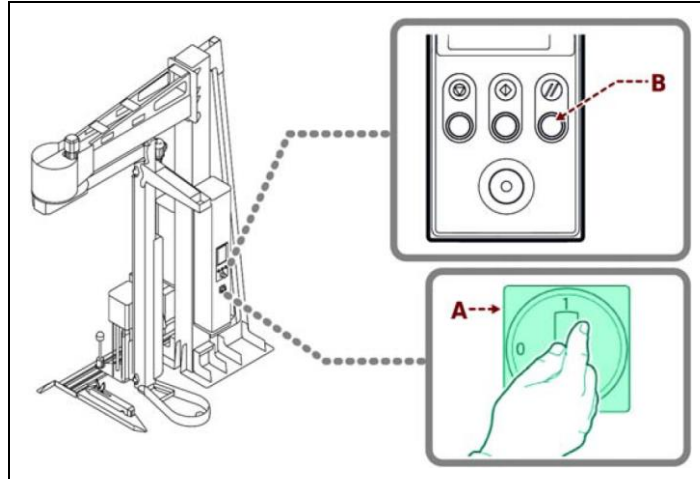

## 6.16.CYCLE PARAMETERS SETTING

1. Switch on the machine (See "Machine switching on and off").
2. Choose the recipe number.
3. Press the button of the parameter to be edited to display the current value.
4. Press the buttons + / -, or scroll with the cursor, to increase or decrease the value until the required one is obtained (See "programming window").  
This value will be stored in the relevant program.

## 6.17. DESCRIPTION OF THE WRAPPING CYCLES

### 6.17.1. SINGLE WRAPPING CYCLE

To select the “single cycle”, press the button (**C1**) and check that the relevant LED turns on.

The film carriage starts moving from the pallet base and stops when it reaches the upper end, after having performed the required number of wrapping turns at the base and at the upper end of the pallet.

Press the “**START**” button again to perform a second single wrapping cycle which starts from the top and goes down until reaching the pallet base.

(See Paragraph “Wrapping cycle page”).

0 START

1 STOP

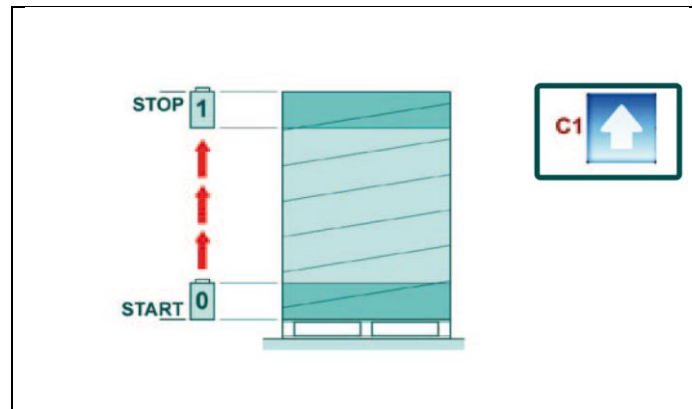

### 6.17.2. DOUBLE WRAPPING CYCLE

To select the “double cycle”, press the button (**C2**) in order to display the corresponding icon.

The film carriage starts moving from the pallet base, rises until reaching the upper end and moves down until reaching the base, performing a double load wrapping.

(See Paragraph “Wrapping cycle page”).

0 START

1 STOP

2 START

3 STOP

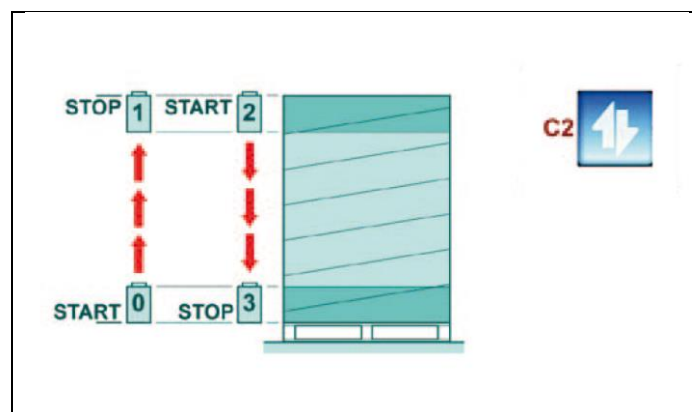

### 6.17.3. WRAPPING CYCLE WITH FEEDER

To select the cycle, press the button (C3) in order to display the corresponding icon.

The machine performs a cycle aimed at making it easier for the operator to completely cover the pallet and ensuring the higher possible level of protection.

The film carriage rises until reaching the carriage upper end, moves down again by approximately 300 mm and stops in this position.

At this point, the operator, after placing the covering sheet onto the top of the pallet, activates the cycle again by pressing the "START" button.

The carriage rises until reaching the pallet upper end, performs the programmed upper wrapping turns and moves down to complete the cycle.

In this way, the position of the covering sheet, tightly bound to upward and downward film turns, is the most suitable for ensuring an optimum protection of the load against external agents (water, dust, etc.).

Please refer to "Wrapping cycle page".

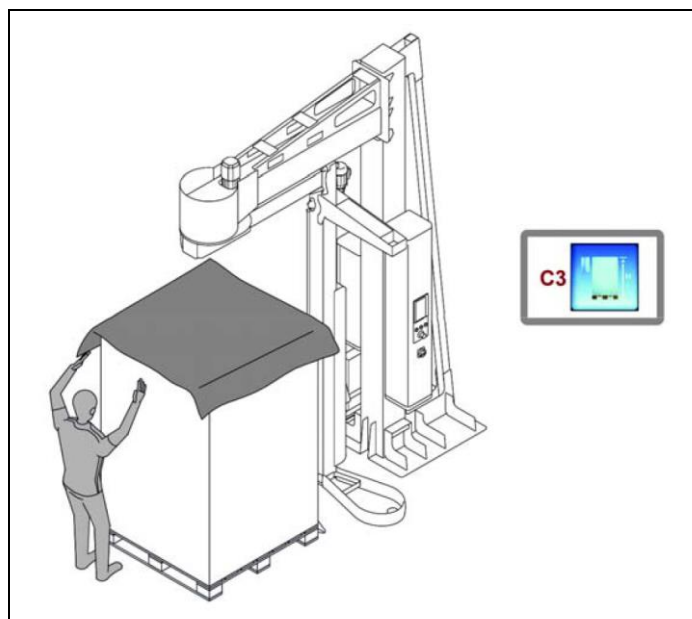

## 6.18. CYCLE START AND STOP

Proceed as follows.

1. Place the pallet in the middle of the packaging area and move the loading device away.
2. Block the film edge at the bottom of the product to be packed.
3. Press the "Cycle Start" button (A).  
The machine completes the cycle and stops automatically.
4. Cut the film (If necessary).
5. Remove the pallet and position a new pallet to start a new cycle.



### Important

To temporarily suspend the cycle, press the "Cycle stop" button (B).  
Press the "Cycle Start" button (A) to restart it.

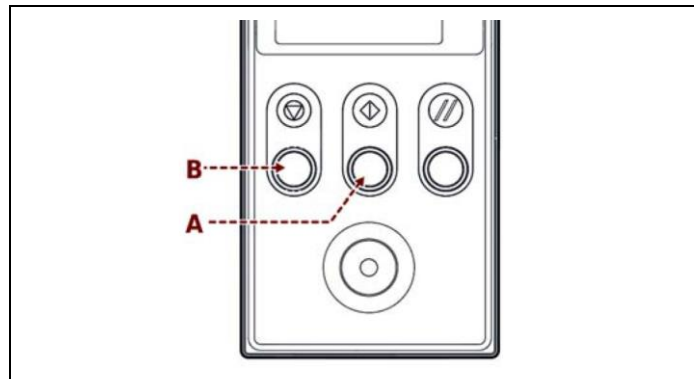

## 6.19.SPOOL LOADING

1. Insert the film reel into its seat on the film carriage.
2. Gather the film to make a thin cord and make it pass between the double-cone surfaces.



### Important

Unwind the film following the path engraved on the film carriage plate.

3. Pull the cord outwards.  
The film automatically moves down to the roller and covers it over its entire length.
4. Block the film edge to the pallet's corner or, if present, to the clamp.

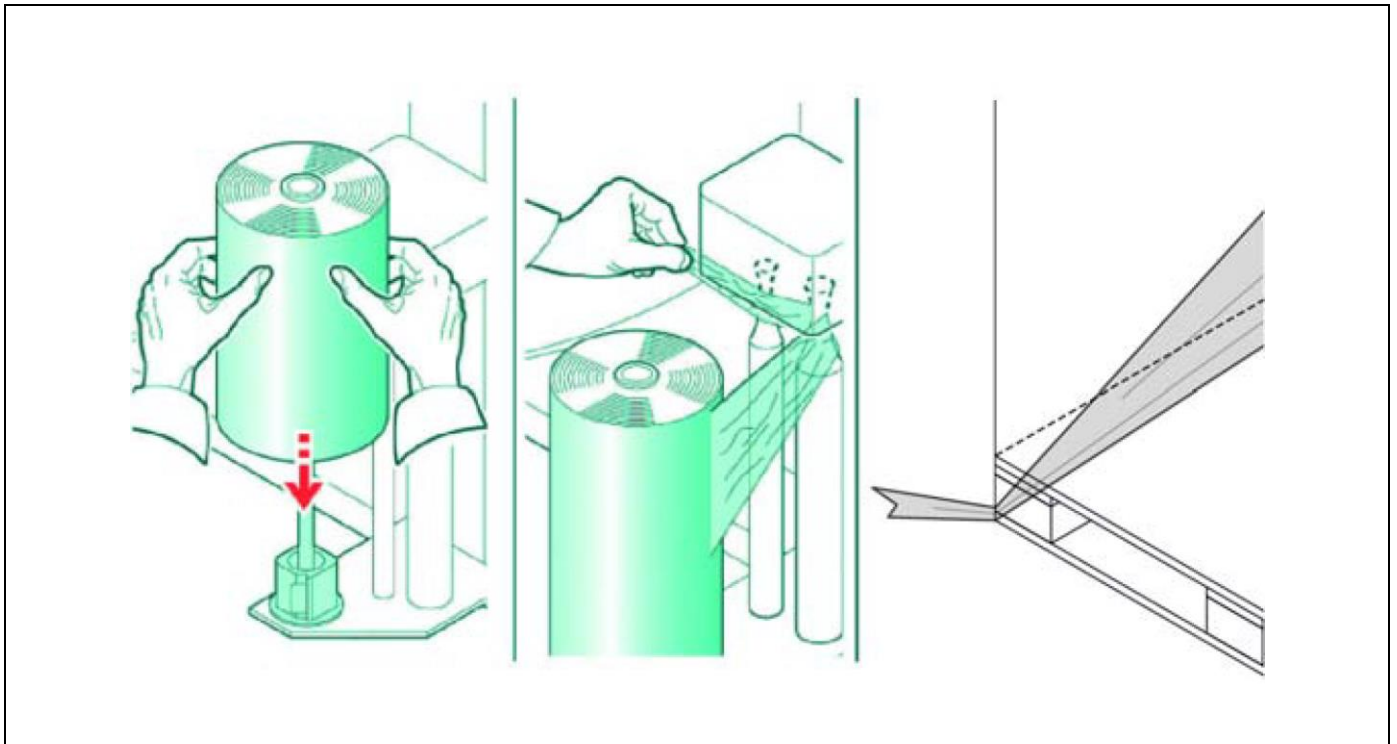

To allow the unwinding of the film on carriages of “PVS” - “PDS” type, it is necessary to press the roller rotation button (C) on the film carriage.

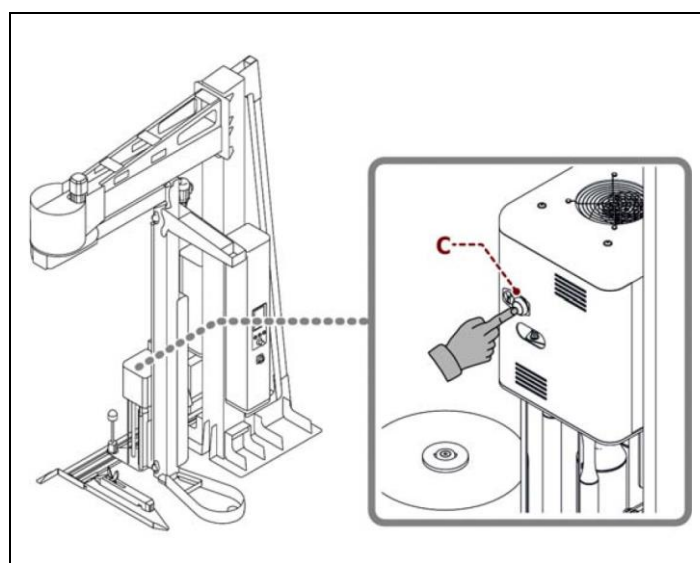

## 7. MAINTENANCE INFORMATION

### 7.1. RECOMMENDATIONS FOR MAINTENANCE

- Proper maintenance will allow a longer life span and constant compliance with safety requirements.
- Before performing any operation, the authorised operator must make sure to have understood the "Instructions for use".
- Pay attention to the safety warnings, do not misuse the machine and assess the possible residual risks.
- Carry out the interventions with all the safety devices enabled and wear the required PPE.
- Indicate the intervention areas and prevent access to the devices that, if activated, could cause unexpected hazards and compromise safety.
- Do not carry out interventions that are not described in the manual but contact an service centre authorised by the Manufacturer.
- Do not dispose of materials, polluting liquids and the waste generated during the interventions into the environment but dispose of them according to the standards in force.



#### **Danger - warning**

Before performing any maintenance operation, activate all safety devices provided and evaluate whether it is necessary to inform the personnel operating on the machine and the personnel nearby.

In particular, demarcate the neighbouring areas to prevent access to the devices that could, if activated, cause unexpected hazardous conditions posing a risk for people's safety and health.



#### **Danger - warning**

Maintenance operations must be performed with the machine disconnected from the power and pneumatic supplies.

The periodical check of the operation of some of the most important parts of the machine, may help to avoid operation problems and to maintain the machine to the maximum operating levels.

## 7.2. PERIODICAL MAINTENANCE INTERVALS



### Important

Keep the machine in maximum efficiency conditions and perform all the scheduled maintenance operations provided for by the Manufacturer.

Proper maintenance will provide the best performance, a longer life span and constant compliance with safety requirements.

Maintenance interval table



Frequency	Component	Type of intervention	Intervention mode	Reference
Every 40 hours	Machine	Cleaning	cloth or air blow	-
	Air filter unit	Condensate drainage	-	See "Condensate drainage"
		Filter cleaning	Clean with an air jet and alcohol	See "Cleaning the air filter"
Every 200 hours	Rubber rollers	Cleaning	Clean with alcohol	-
	Lifting belt and pulleys	Check	Visual check of the wear condition	Please refer to "Lifting belt and pulley inspection"
		Tensioning check	Adjust	See "Film carriage lifting chain adjustment"
	Slewing ring	Greasing	-	See "Lubrication point diagram"
	Carriage sliding guide shoes	Check	-	-
	Reduction units and gearmotors	Checking lubricant level <sup>1</sup>	Top up, if necessary, with lubricant of the same type	See lubricant table
	Gear wheels of carriage pre-stretch gears	Greasing	-	See "Lubrication point diagram"
Every 2000 hours	Carriage sliding guide shoe seal	Replacement	Replace	Please refer to "Replacement of carriage sliding guide shoe seal"
	Safety devices	Efficiency check	-	-
	Cutting wire (optional)	General check	Check for wear and replace, if necessary. Contact the Assistance Service	Please refer to "Cutting wire replacement (optional)"
Every 5000 hours	Reduction units and gearmotors	Lubricant change <sup>1</sup>	Use lubricant with the same characteristics	See lubricant table

<sup>1</sup> Reduction units and gearmotors can be lubricated with grease, oil or for life, depending on their type. Topping up and/or change must not be performed in case of life-lubed reduction units and gearmotors.

### 7.3. LUBRICATION POINT DIAGRAM

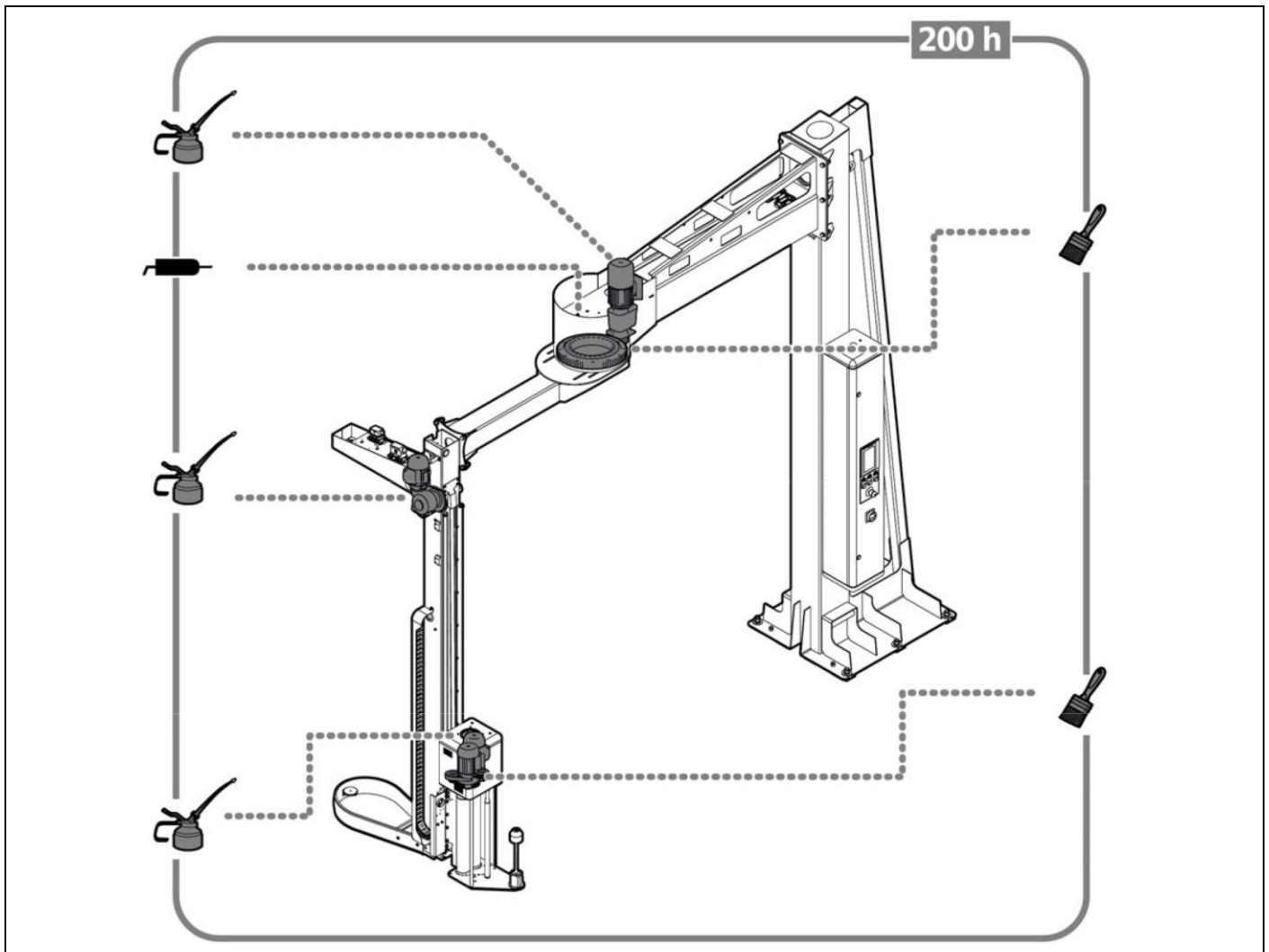
The diagram shows the main parts concerned by the lubrication interventions and their intervals.



	Spread grease over it.
	Check the lubricant level. Do not top up and/or change in life-lubed reduction units and gearmotors.
	Inject grease.

#### 7.4. LUBRICANT TABLE

The table below lists the specifications of the lubricants recommended by the Manufacturer for each component and/or areas of reference.

**Use lubricants (oils and greases) recommended by the Manufacturer or with similar chemical-physical features.**

##### Lubricant characteristics

Lubricant type	Code	Parts to be lubricated
Mineral oil	23°C / 50°C - 320 CST 40°C MELLANA OIL 320 IP SPARTAN EP 320 ESSO BLASIA 320 AGIP MOBILGEAR 632 MOBIL OMALA EP 320 SHELL ENERGOL GR-XP 320 BP	Gear reduction unit
Mineral oil	32°C / 50°C - 460 CST 40°C MELLANA OIL 460 IP SPARTAN EP 460 ESSO BLASIA 460 AGIP MOBILGEAR 634 MOBIL OMALA EP 460 SHELL ENERGOL GR-XP 460 BP	Worm screw reduction unit
Grease	TELESIA COMPOUND B IP STRUCTOVIS P LIQUID KLUBER TOTALCARTER SYOO TOTAL	Gear reduction unit and worm screw reduction unit
Synthetic oil	TELESIA OIL IP SYNTHESO D 220 EP KLUBER BLASIA S 220 AGIP	Gear reduction unit and worm screw reduction unit
Lithium grease	ALVANIA R2 SHELL HL 2 ARAL ENERGREASE LS2 BP BEACON 2 ESSO MOBILIX MOBIL	Bearings with support
Grease	-20°C / +110°C GR MU EP 2 AGIP <sup>1</sup> -20°C / +130°C ARALUB HLP 2 ARAL -20°C / +130°C ENERGREASE LS-EP 2 BP -20°C / +120°C SPHEEROL EPL 2 CASTROL -20°C / +130°C LAGERMEISTER EP 2 LUBRITECH -20°C / +120°C BEACON EP 2 ESSO -20°C / +120°C MOBILUX EP 2 MOBIL -20°C / +130°C ALVANIA EP 2 SHELL -25°C / +120°C MULTIS EP 2 TOTAL -25°C / +130°C CENTOPLEX EP 2 KLUBER	Lubrication of the roller bearings (slewing ring)

Grease	-20°C / +110°C GR MU EP 2 AGIP <sup>1</sup> -25°C / +180°C ARALUB MKA-Z-1 ARAL -30°C / +140°C ENERGREASE LC2 BP -20°C / +120°C LMX CASTROL -10°C / +140°C CEPLATTYN KG 10 HMF LUBRITECH -20°C / +130°C Multi purpose grease (Molly) ESSO -20°C / +120°C MOBILGEAR OGL 461 MOBIL -10°C / +200°C MALLEUS OGH SHELL -20°C / +200°C GARDREXA GR-1 AL TOTAL -30°C / +200°C GRAFLOSCON C-SG 0 ULTRA KLUBER	Lubrication of slewing ring and pinion teeth
--------	--	--

- <sup>1</sup> Reduction units and gearmotors can be lubricated with grease, oil or for life, depending on their type. Topping up and/or change must not be performed in case of life-lubed reduction units and gearmotors.



**Important**

Do not mix together oils of different brands or having different characteristics.

## 7.5. CONDENSATE DRAINAGE

1. Close the tap (A) and check the level of condensation in the container (B).
2. Unscrew, if necessary, the valve (C) to drain the condensation.
3. Push the valve (C) upwards until all condensation is let out.
4. Tighten the valve (C) again.

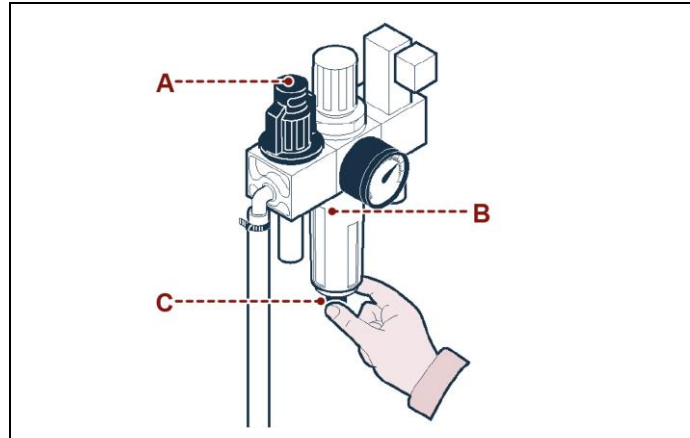

## 7.6. AIR FILTER CLEANING

1. Unscrew the container (B) with the specific wrench.
2. Remove the filter, clean it with compressed air and wash it, if necessary, with petrol or trichloroethylene.
3. Refit the filter and tighten the container (B).

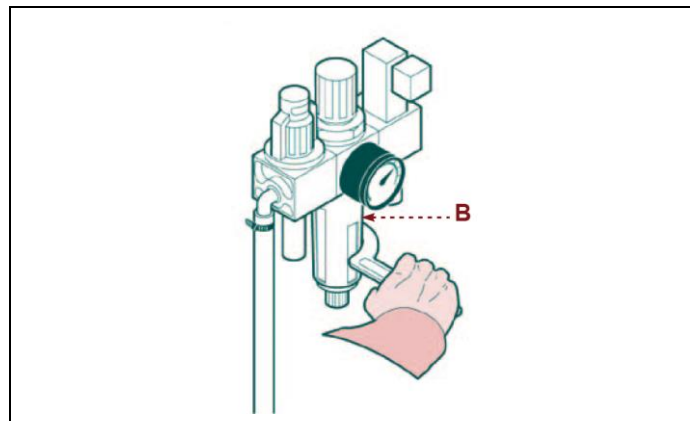

## 7.7. LIFTING BELT AND PULLEY INSPECTION

1. Loosen the screws (A) and remove the inspection guards (B-C).
2. Check the wear condition of the belt and the pulleys.  
If replacement is necessary, contact the assistance service.
3. Refit the guards (B-C) by tightening the screws (A).

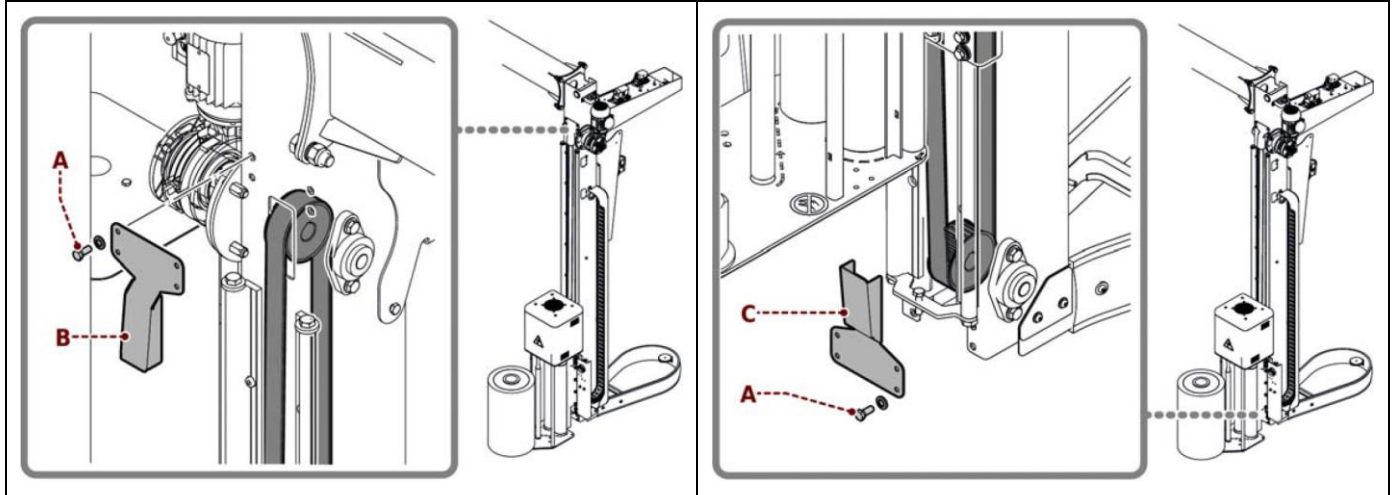

## 8. FAULT INFORMATION

### 8.1. ALARM MESSAGES

In the event of a breakdown during operation the machine stops automatically and alarm messages appear on the display.

The table lists the displayed messages, the type of problem, the causes and possible solutions.



#### Important

For these operations a precise technical expertise or ability is required; therefore, these operations must be exclusively performed by qualified personnel with certified experience acquired in the specific field of intervention.

#### List of alarms

Code	Problem	Cause	Solution
E01	Emergency mushroom-head button alarm.	Emergency push button pressed	Reset by turning the button in the direction of the arrow and press "Reset"
E04	Protection alarm	Intervention of safety barriers or open door	Remove the obstacle and press the "Reset" button
E30	Inverter alarm: 1. Table 2. Carriage 3. Stretch 4. Pre-stretch	POWER DRIVER LOW POWER DRIVER HIGH OVER VOLTAGE MAX VOLTAGE UNDER VOLTAGE HW POWER CURRENT OVER HEAT PHASE FAIL CURRENT MAX CURRENT INT MAX PARAMETER WRONG COM.ERROR	Contact technical support
E60	"Film breakage" alarm	The film has broken or the reel is finished	Insert the film or replace reel.
E61	Blocked arm alarm	A fault or an obstacle is preventing the arm from rotating	Solve the fault or remove the obstacle and press the "Reset" button
E64	Blocked carriage alarm	The carriage has stopped its travel	Remove the obstacle and press the "Reset" button
E67	Thermal cutout alarm	Possible overheating on the rotation brake.	Contact technical support
E68	Crash with CW alarm	Possible crash between rotating arm and sealing unit (only for CW machines)	Move back the sealing device with a manual control from H.M.I. and check the operation of the corresponding positioning sensor
E83	MODBUS alarm.	Electronic fault	Contact technical support

## 9. REPLACEMENT INFORMATION

### 9.1. RECOMMENDATIONS FOR REPLACING MACHINE PARTS

- Before performing any operation, the authorised operator must make sure to have understood the "Instructions for use".
- Carry out the interventions with all the safety devices enabled and wear the required PPE.
- Demarcate the surrounding areas and put in place adequate safety measures, as provided for by the standards on workplace safety, in order to prevent and minimise the risks.
- Do not carry out interventions that are not described in the manual but contact an service centre authorised by the Manufacturer.
- Do not dispose of materials, polluting liquids and the waste generated during the interventions into the environment but dispose of them according to the standards in force.
- Replace the components only with original spare parts or parts with similar design and construction features. The use of similar but non-original spare parts may result in improper repairs, altered performance and economic damage.
- Safety components and/or devices must be replaced only with original spare parts to preserve the safety level required.



#### **Important**

Before performing any maintenance operation, activate all safety devices provided and evaluate whether it is necessary to inform the personnel operating on the machine and the personnel nearby.

In particular, demarcate the neighbouring areas to prevent access to the devices that could, if activated, cause unexpected hazardous conditions posing a risk for people's safety and health.

When replacing worn parts, use only original spare parts.

The Manufacturer is not responsible for any damage to property or injuries to people caused by the use of non-genuine spare parts or which may result from repairs not authorised by the Manufacturer.

When ordering new spare parts, follow the instructions given in the spare parts catalogue.

## 9.2. CUTTING WIRE REPLACEMENT (OPTIONAL)

1. Loosen the fastening screws (A).
2. Place the new wire (B).
3. Tighten the screws (A) when finished.

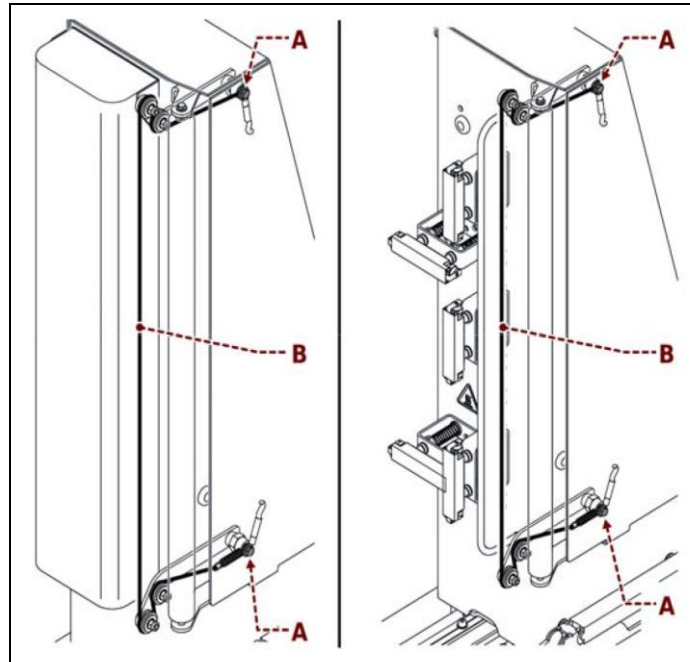

### 9.3. REPLACEMENT OF CARRIAGE SLIDING GUIDE SHOE SEAL

1. Remove the screws (A).
2. Remove the screw (B).
3. Turn the plate (E) so as to avoid interfering with guide shoe disassembly.
4. Disassemble the guide shoes (C) by making them slide along the guide.  
Replace the guide shoes with the seal.
5. Refit the guide shoes on the guide and fasten them with the screws (A).
6. Refit the screw (B).
7. Repeat the operations described so as to replace the seals on the other guide shoes.



**Danger - warning**

Replace them on one side at a time.

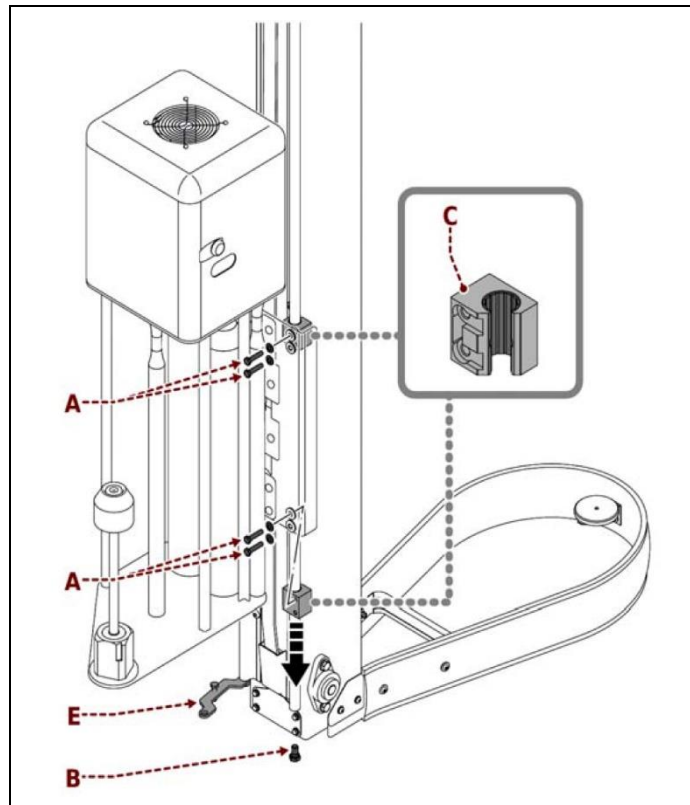

## 9.4. RECOMMENDED SPARE PARTS LIST

List of the spare parts that wear easily and that should be always available to avoid long machine downtimes:

- Cutting wire.
- No. 4 sliding guide shoes for sealing/spreading device activation.
- No. 4 sliding guide shoes for carriage activation.
- No. 1 carriage clutch (Only for "PDS" type film carriages).
- No. 1 drive belt (Only for "PDS-PVS" type film carriages).

To order them, contact your local dealer and refer to the spare parts catalogue.



### Important

Replace worn parts with original spare parts.  
Use oils and greases recommended by the Manufacturer.  
All the above will ensure the proper operation of the machine and the correct level of safety.

## 9.5. MACHINE DECOMMISSIONING AND SCRAPPING

### 9.5.1. MACHINE DECOMMISSIONING

- Cut off any supply to the machine (power, pneumatic, etc.) so that it cannot be restarted and position it in a place that cannot be easily accessed.
- Empty the systems, which contain hazardous substances, in a proper manner and in compliance with the laws in force at workplaces and with those on environmental protection.

### 9.5.2. MACHINE SCRAPPING

- Scrapping must be performed by authorised centres with experienced personnel and by using the appropriate equipment for safe operating conditions.
- The person who performs the scrapping must identify any possible residual energies and implement a "safety plan" to eliminate unexpected risks.
- The components must be selected according to the chemical and physical features of the material and disposed of separately, in accordance with the applicable laws.
- Empty the systems, which contain hazardous substances, in a proper manner and in compliance with the laws in force at workplaces and with those on environmental protection.

## 10. ANNEXES

### 10.1. WARRANTY CONDITIONS

**Robopac S.p.A.** commits, within the limits described herein, to replace or repair, free of charge, the parts that are defective during the 12 (twelve) months following the date indicated on the company's shipping documents.

To utilise the warranty, the user must immediately notify the company of the detected fault, always referring to the machine serial number.

**Robopac S.p.A.**, in its final judgement, will decide whether to replace the defective part or request it to be shipped for tests and/or repair.

By replacing or repairing the defective part, **Robopac S.p.A.** fully complies with its warranty obligations and will be released from all liabilities and obligations relative to transport, travel and lodge expenses for technicians and installers.

**Robopac S.p.A.** will in no case be held responsible for any losses due to lack of production or injuries to persons or damage to things caused by malfunctions or forced downtime of the machine covered by the warranty.

#### THE WARRANTY DOES NOT COVER:

- Transport failures.
- Damage due to incorrect installation.
- Improper use of the machine or negligence.
- Tampering with or repairs by unauthorised personnel.
- Lack of maintenance.
- Parts subject to normal wear and tear.

For purchased components and parts, **Robopac S.p.A.** offers the user the same warranty conditions that the company obtains from the suppliers of the aforementioned components and/or parts.

**Robopac S.p.A.** does not guarantee the conformity of machines to current standards in countries that are not part of the European Union.

Any adjustment to the regulations in force in the Country in which the machine is installed, will fall under the full responsibility of the user, who will be responsible also for the changes made, releasing **Robopac S.p.A.** from any obligation and/or liability relative to any claim that may be submitted by third parties due to non-compliance with the referenced standards.

## 10.2.PNEUMATIC DIAGRAM

### Legend:

- A. Sealer actuating pneumatic cylinder
- B. Clamp actuating pneumatic cylinder

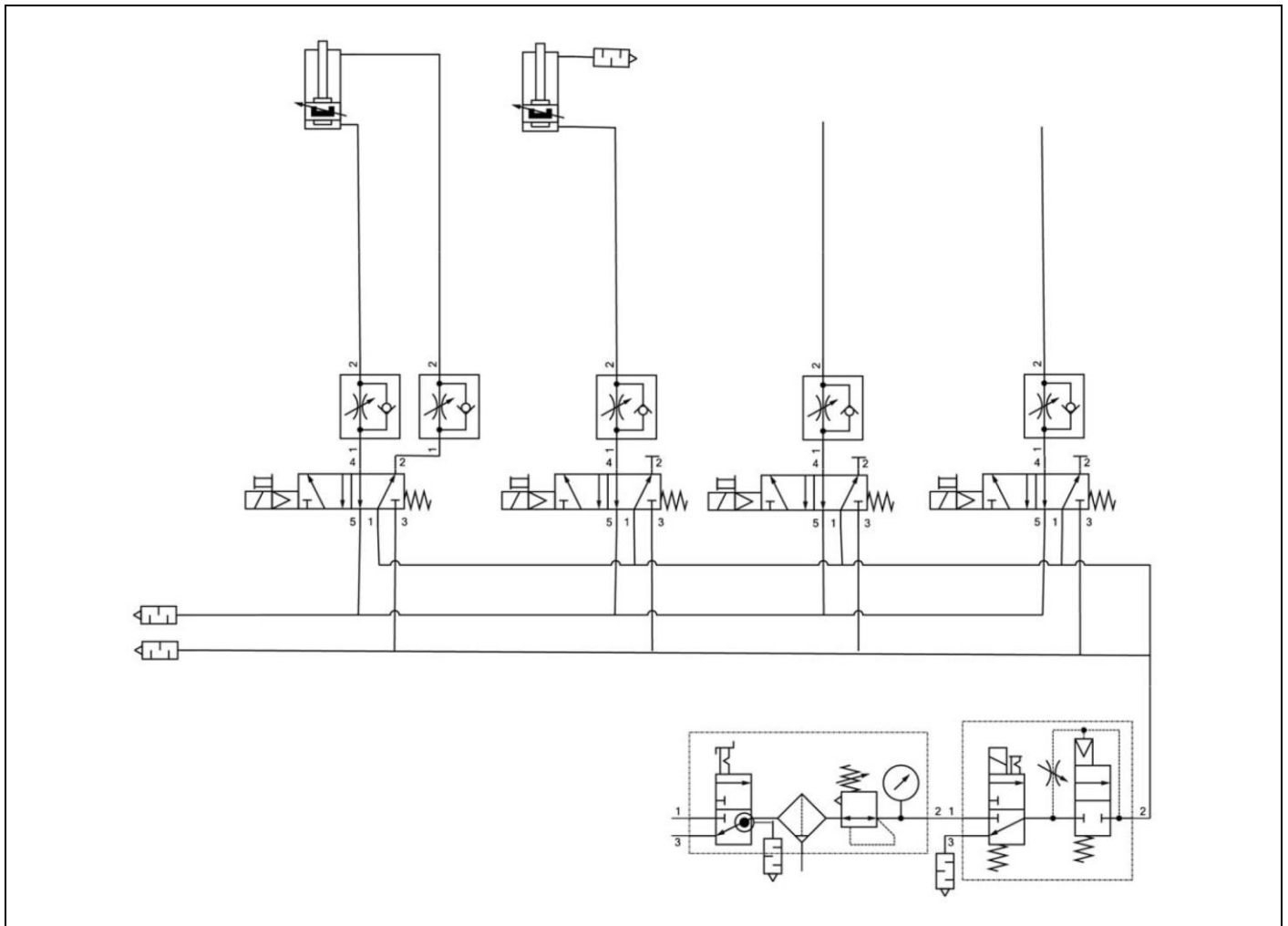

# DECLARATION OF CONFORMITY

(Annex II 1.A of Directive 2006/42/EC)

**The manufacturer:**

**Robopac S.p.A.**  
**Via Fabrizio da Montebello, 81**  
 47892 - Gualdicciolo  
 Republic of San Marino

of the machine identified as follows:

DENOMINAZIONE DENOMINATION	
MODELLO MODEL	
MATRICOLA SERIAL NUMBER	

## DECLARES

under its own responsibility that this machine is compliant with the following European directives:

DIRECTIVE 2006/42/EC OF THE EUROPEAN PARLIAMENT AND OF THE COUNCIL of 17 May 2006 on machinery, and amending Directive 95/16/EC;

DIRECTIVE 2014/30/EU OF THE EUROPEAN PARLIAMENT AND OF THE COUNCIL of 26 February 2014 on the harmonisation of the laws of the Member States relating to electromagnetic compatibility;

and with the following harmonised standards at the applicable points:

EN ISO 12100:2010, EN 60204-1:2018, EN 415-10:2014.

**THE PERSON AUTHORISED BY THE MANUFACTURER TO PREPARE THE TECHNICAL REPORT AND DRAW UP THE DECLARATION OF CONFORMITY IS:**

**Engineer Cristiano Casale**  
**R&D Manager**

**c/o Aetna Group S.p.A.**

**S. P. Marecchia, 59**

**47826 Villa Verucchio**

**Rimini (Italy)**

**Date and place of signature**

**Robopac S.p.A.**

**San Marino,**

**Engineer Cristiano Casale**  
**R&D Manager**

---

**ROBOPAC SPA**

Via Fabrizio da Montebello, 81 – 47892 Gualdicciolo, Repubblica S. Marino (RSM)  
Phone (+378) 0549 910511 - Fax (+378) 0549 908549 – 905946  
<http://www.robopac.com>