

TECHNICAL DOCUMENTATION

- ROTARY



TECHNICAL DOCUMENTATION - ROTOTECH





Norm. Tecn.
60.2.66_08

TECHNICAL DOCUMENTATION
ROTARY-ROTOTECH


Date:
November 2021

Rev.12

ENGLISH


Pag. 3 / 100

Date	Revisions	Revision Reasons	Issue	Chechek by	Approved by
03/11/2016	00	First Issue	<i>Zavoli G.</i>	<i>Zavoli G.</i>	<i>Zavoli G.</i>
21/04/2017	01	New carriages / Stretch control / Dip switches	<i>Baldinini F.</i>	<i>Baldinini F.</i>	<i>Baldinini F.</i>
18/09/2017	02	New photocell for black products	<i>Baldinini F.</i>	<i>Baldinini F.</i>	<i>Baldinini F.</i>
20/02/2018	03	New parameters P31-P40	<i>Baldinini F.</i>	<i>Baldinini F.</i>	<i>Baldinini F.</i>
14/06/2018	04	P35 parameter – new / old PID	<i>Baldinini F.</i>	<i>Baldinini F.</i>	<i>Baldinini F.</i>
10/07/2018	05	Index realization and new radio control	<i>Baldinini F.</i>	<i>Baldinini F.</i>	<i>Baldinini F.</i>
29/01/2019	06	Setting procedure for emergency bumper photocells	<i>Baldinini F.</i>	<i>Baldinini F.</i>	<i>Baldinini F.</i>
18/06/2019	07	R-connect, change in configuration parameters, counters page	<i>Baldinini F.</i>	<i>Baldinini F.</i>	<i>Baldinini F.</i>
25/09/2019	08	Alarm E67 and Thermal Alarm (E62, E66)	<i>Baldinini F.</i>	<i>Baldinini F.</i>	<i>Baldinini F.</i>
05/12/2019	09	Appendix 1 : Security Module for TP photocells	<i>Baldinini F.</i>	<i>Baldinini F.</i>	<i>Baldinini F.</i>
12/04/2021	10	Alarm E83 upgrade	<i>Baldinini F.</i>	<i>Baldinini F.</i>	<i>Baldinini F.</i>
23/04/2021	11	New Kinko panel	<i>Baldinini F.</i>	<i>Baldinini F.</i>	<i>Baldinini F.</i>
12/2021	12	Change of some motor parameters	<i>Baldinini F.</i>	<i>Baldinini F.</i>	<i>Baldinini F.</i>


 Norm. Tecn. 60.2.66_08	TECHNICAL DOCUMENTATION ROTARY-ROTOTECH	Date: November 2021	Rev.12
	ENGLISH	Pag. 4 / 100	

Index


MACHINE LAY-OUT.....	8
CARRIAGE DESCRIPTION.....	9
OPERATOR PANEL DESCRIPTION.....	12

 Norm. Tecn. 60.2.66_08	TECHNICAL DOCUMENTATION ROTARY-ROTOTECH	Date: November 2021	Rev.12
	ENGLISH	Pag. 5 / 100	

DESCRIPTION AND MAIN ELECTRICAL PANEL LAYOUT	13
DESCRIPTION AND MAIN ELECTRICAL PANEL LAYOUT (USA Version only)	15
ELECTRICAL PANEL ON ROTATION ARM DESCRIPTION	17
ELECTRICAL PANEL CLUMP-CUTTER-WELDER EQUIPMENT DESCRIPTION	18
ELECTRONIC CARDS DESCRIPTION	19
PLC Main Board (U1) - – CODE 1430300238	19
Inverter Card INV01ROB_2 (T1) – CODE 1430300271	22
Inverter card INV01ROB_2 (T2) – CODE 1430300271	24
Expansion Card PRES04ROB (U11) - – CODE 1430300256.....	26
Check function of load cell (on carriage connector).....	27
Control Pressure Card DCM01ROB (U14) – CODE 1430300268	28
Control Roping Device Card DCM01ROB (U14) – CODE 1430300268.....	29
Leds Status Machine Card LED01ROB (U13) – CODE 1430300245	30
LIST OF RECIPES DATA	31
MACHINE OPTIONS.....	35
OPERATOR PANEL PASSWORD USE.....	36
INITIAL TOUCH SCREEN PANEL SETTINGS (ROBOPAC USE ONLY)	38
VARIOUS TOUCH SCREEN OPERATOR PANEL FUNCTIONS	39
HMI Setting.....	39
SW / HW Information.....	39
Counter Reset	39

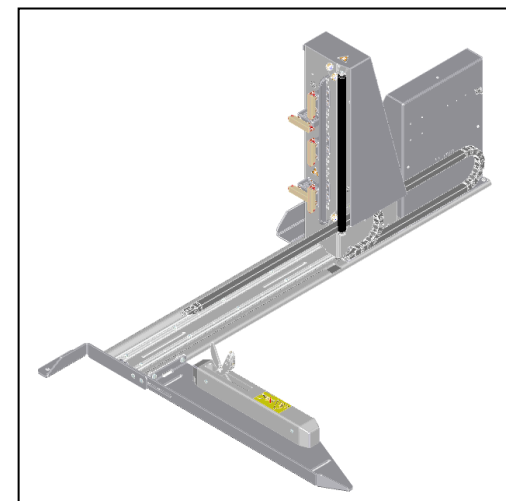
 Norm. Tecn. 60.2.66_08	TECHNICAL DOCUMENTATION ROTARY-ROTOTECH	Date: November 2021	Rev.12
	ENGLISH	Pag. 6 / 100	

MACHINE CONFIGURATION AND INTERNAL PARAMETER LIST	40
Machine Configuration Parameters.....	40
Machine Configuration Parameters <i>(from Software Pack 118.4.2 OCTOBER 2018)</i>	43
Motors Parameters	46
PROCEDURE FOR REPLACING, LOADING SOFTWARE AND CALIBRATION OF ELECTRONIC CARDS	47
TOUCH SCREEN PANEL (U9)	47
New installation MT4414TE-RO KINCO --- till January 2021	47
New installation K-GL070E-RO KINCO --- since January 2021	52
Software update	54
PLC CARD (U1).....	61
EXPANSION CARD (U11)	63
LOAD CELLA CALIBRATION	65
INVERTER CARD (T1 – T2)	66
PRODUCT HEIGHT DETECTION PHOTOCELL CALIBRATION.....	72
Standard photocell (for clear products).....	72
Dark product photocell.....	72
Photocell for black products S65	73
SETTING PROCEDURE FOR PHOTOCELLS ON EMERGENCY BUMPER on U12 Safety Control Unit.....	74
REMOTE CONTROL INSTALLATION & SETTING --- until September 2016 ---	79
RECEIVER RADIO CARD (code 1430300157)	80
REMOTE CONTROL EMITTER CARD CONFIGURATION (code 0590300000).....	82
NEW RADIO CONTROL INSTALLATION --- from September 2016 ---	83
RECEIVER Installation	83
TRANSMITTER Installation.....	85
R-CONNECT DEVICE ACTIVATION.....	86

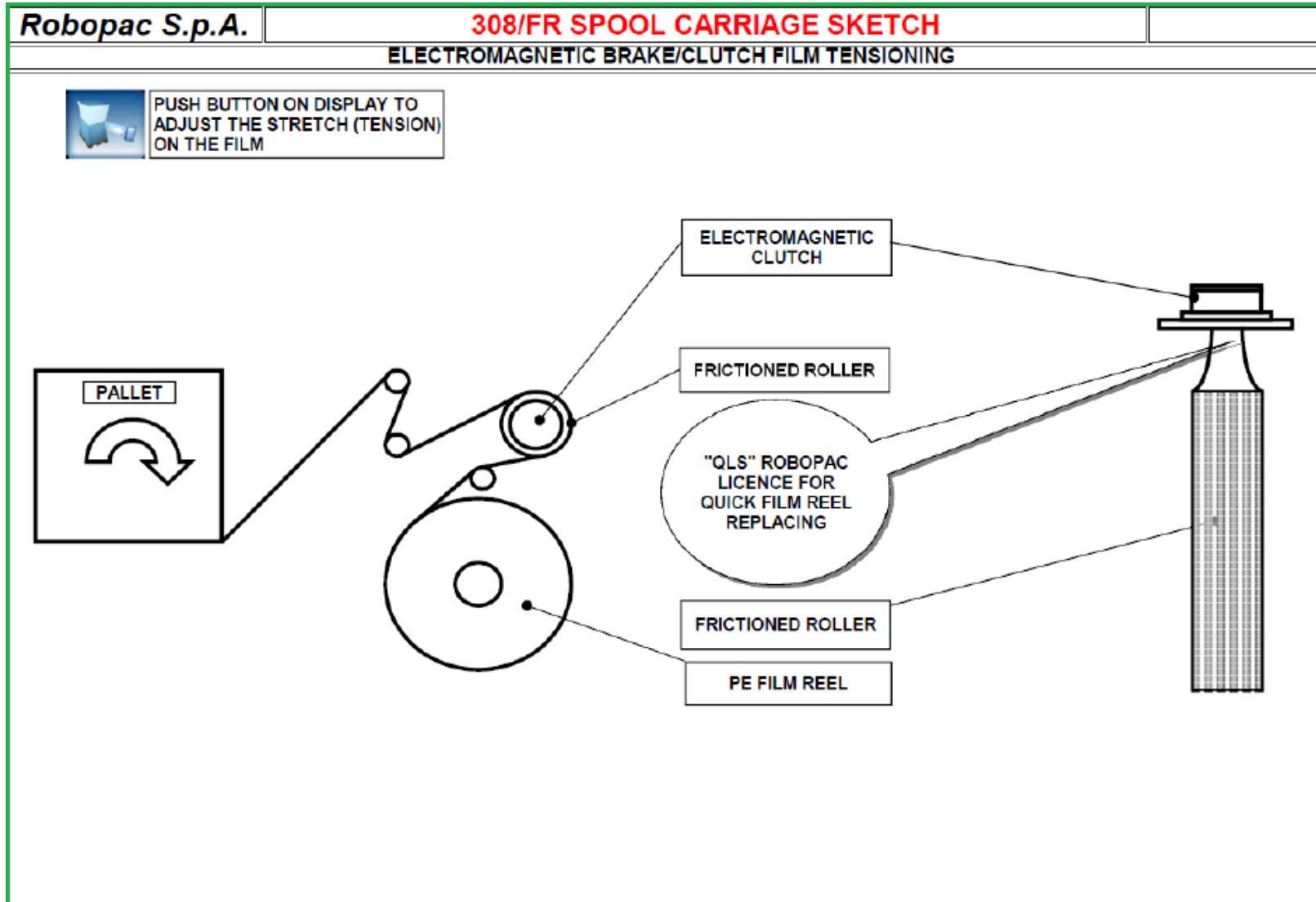
 Norm. Tecn. 60.2.66_08	TECHNICAL DOCUMENTATION ROTARY-ROTOTECH	Date: November 2021	Rev.12
	ENGLISH	Pag. 7 / 100	

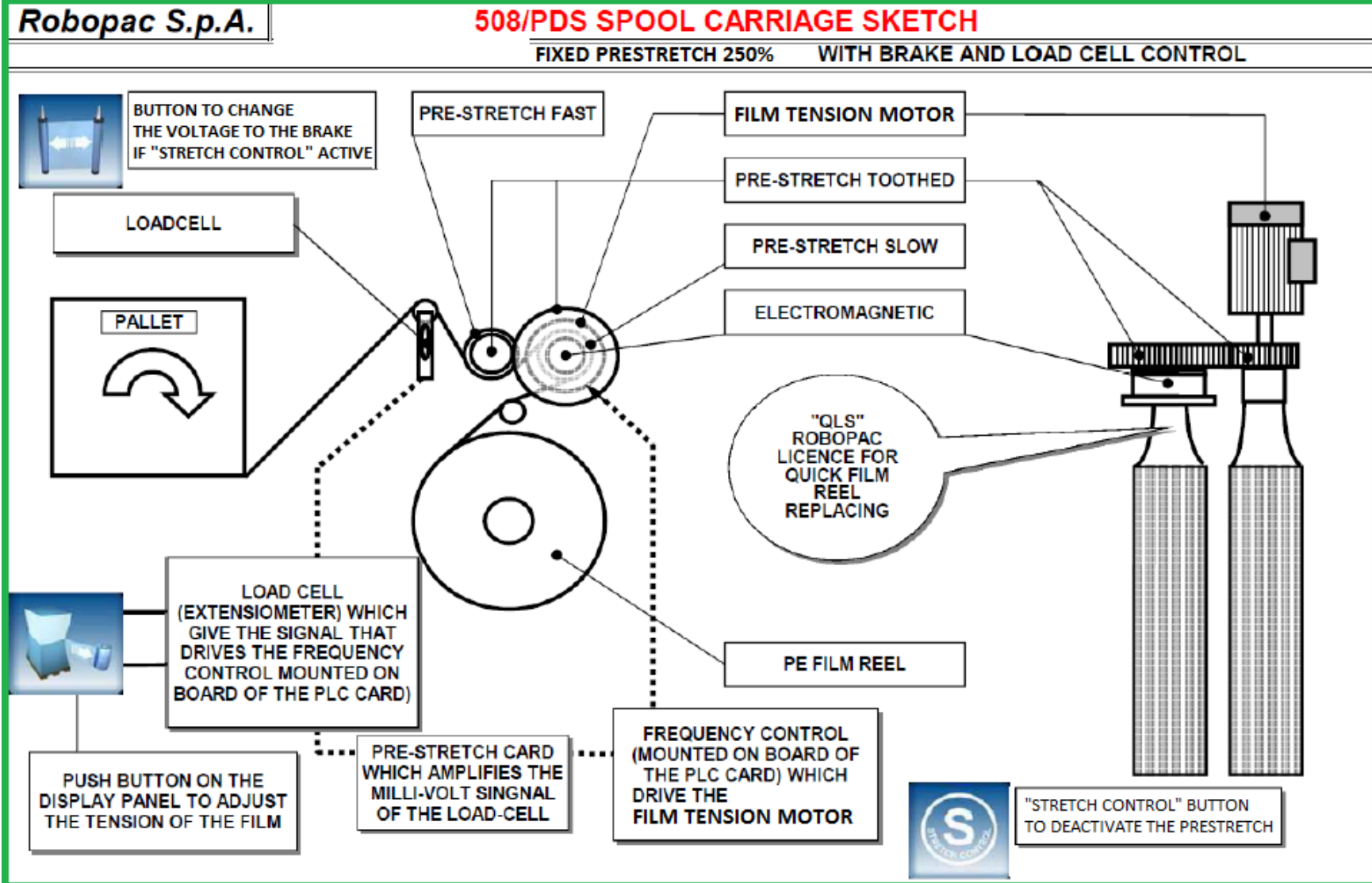
ALARM LIST AND TROUBLESHOOTING.....	87
MECHANICAL AND PNEUMATIC ADJUSTMENTS	97
Rotating arm length adjustment	97
APPENDIX 1 : Security module SG BWS T4 for emergency BUMPER	100

MACHINE LAY-OUT



CARRIAGE DESCRIPTION

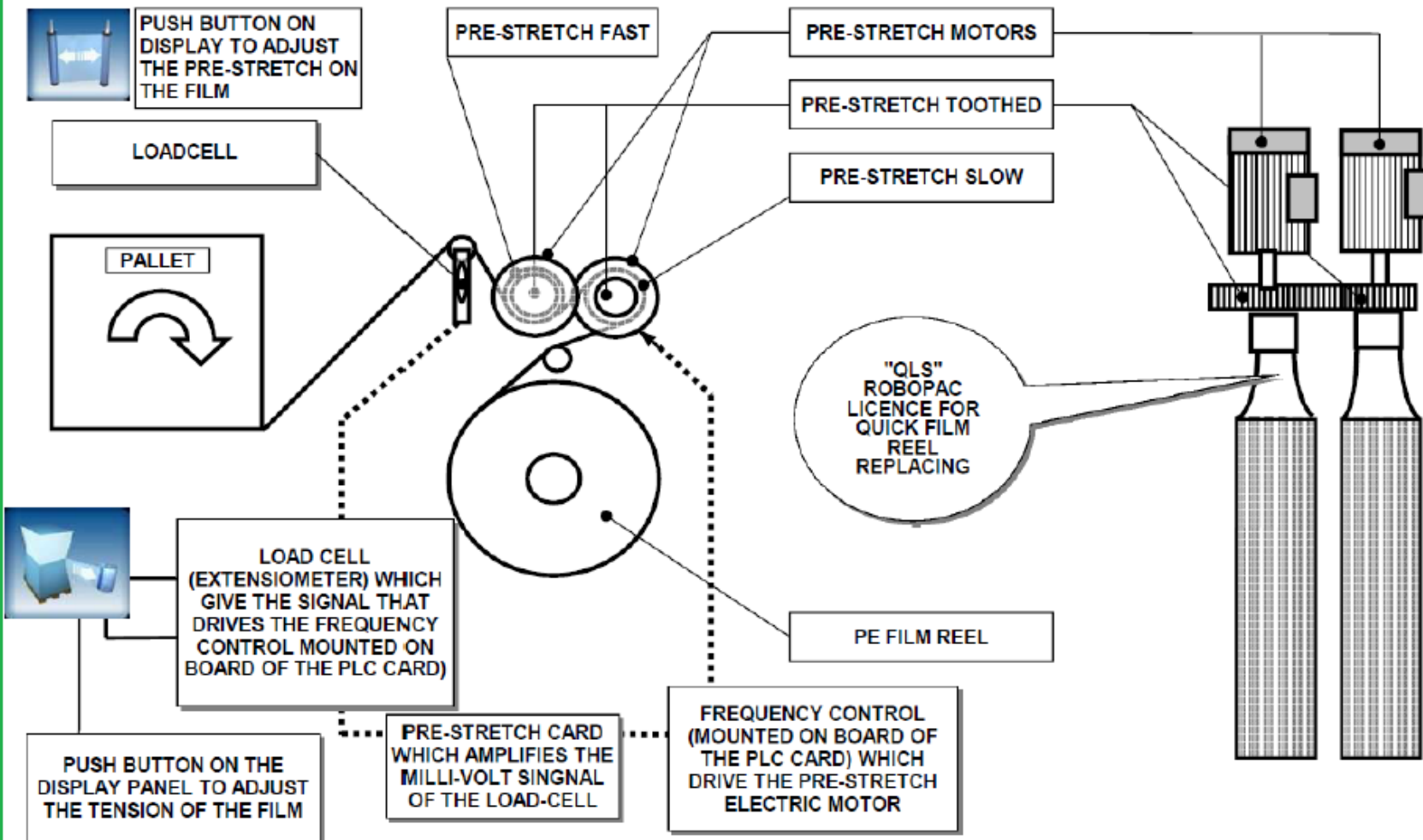




Robopac S.p.A.

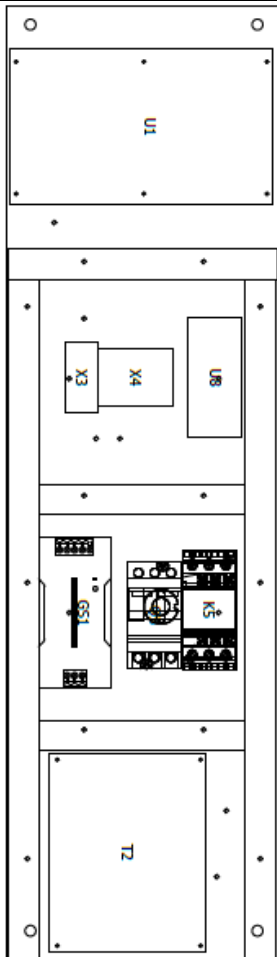
708/PVS SPOOL CARRIAGE SKETCH

POWERED PRE-STRETCH 150% - 400% WITH DOUBLE POWER MOTOR AND LOAD CELL



OPERATOR PANEL DESCRIPTION

<p>Fig.1</p> <p>Fig.1a</p>			<p>“Stop cycle” button It is used to stop the automatic wrapping Cycle</p>
			<p>“Start cycle” push-button It is used to start the automatic wrapping cycle</p>
			<p>“Reset” push-button It is used to reset the machine before restarting after an emergency stop or to restart it after stopping with power supply cut-off.</p>
			<p>Emergency stop push-button It is used to stop with a voluntary action, in case of imminent risk, the organs of the machine that may pose a risk. For further details consult the paragraph “Description of safety devices”</p>
			<p>Main switch for machine’s ON / OFF Turn main switch (A)) (Pic. 1a) on I (ON) to turn on electric power supply.</p>
			<p>Buzzer</p>

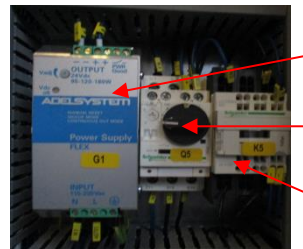
DESCRIPTION AND MAIN ELECTRICAL PANEL LAYOUT

**The part numbers are for information only.
Always check and verify the codes on the wiring diagram
supplied with the machine**

U1 - PLC Card PLC01ROB_1
code 1430300238



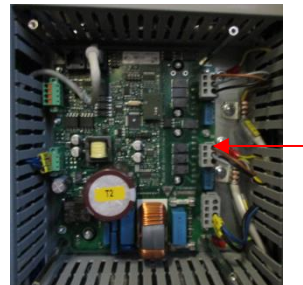
U8 - Safety Module CS-AT-10V024-TF0.3
code 1400300007



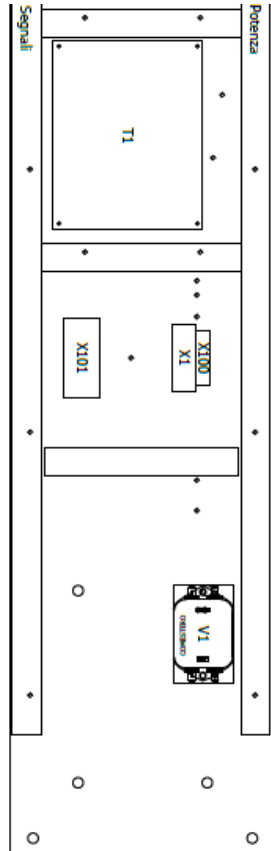
G1 - Stabilized power supply FLEX17024A (ADELSYSTEM) - code 0001346618
G1 - Stabilized power supply S8VKG24024 (OMRON) - code 00L0312760

Q5 - Rotation Motor Brake Thermal Protection
code 0001351718

KM5 - Rotation Motor Brake Enable
code 0001357195



T2 - Inverter Card INV01ROB_2
code 1430300271



T1 - Inverter Card INV01ROB_2
code 1430300271

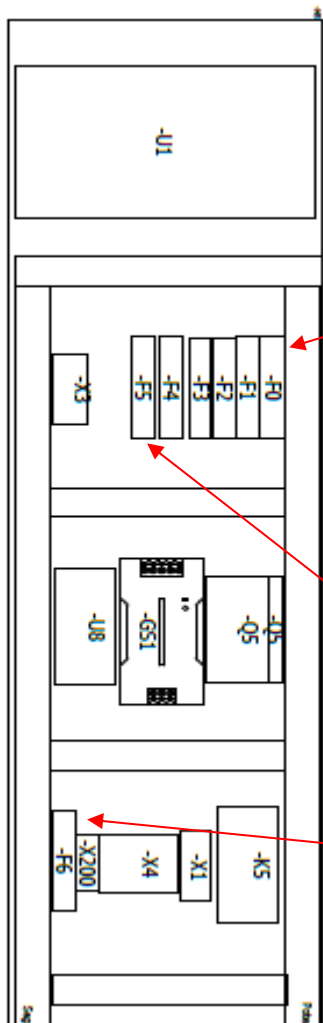


V1 - Main filter
code 00L0202680
code 00L0287639 (new BM 1214 - 1217)

U30 - Radio Remote Receiver
code 1430300157

DESCRIPTION AND MAIN ELECTRICAL PANEL LAYOUT (USA Version only)

**The part numbers are for information only.
Always check and verify the codes on the wiring diagram
supplied with the machine**



F0 – Power fuse (10,3X38 RIT 10A 600V CC UL/CSA)
code 0001304313

F1 - Inverter T1 Fuse (10,3X38 RIT 8A 600V CC UL/CSA)
code 0001304312

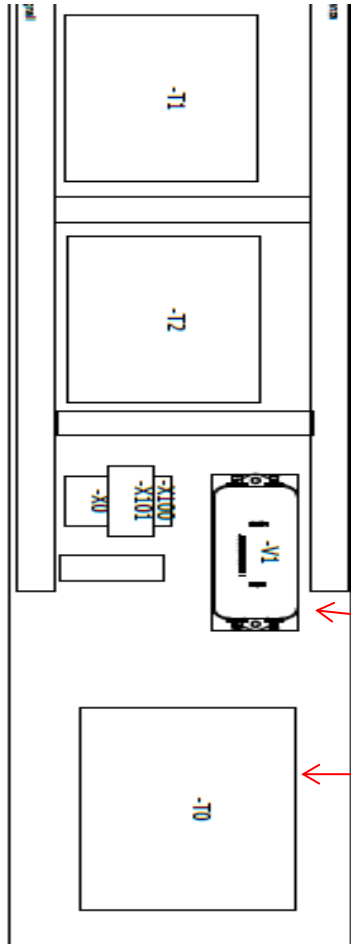
F2 - Inverter T2 Fuse(10,3X38 RIT 8A 600V CC UL/CSA)
code 0001304312

F3 - PLC U1 Fuse (10,3X38 RIT 1A 600V CC UL/CSA)
code 0001304300

F4 - 24VDC Fuse (10,3X38 RIT 4A 600V CC UL/CSA)
code 0001304307

F5 - OUTPUT Power Supply 24VDC Fuse (10,3X38 RIT 4A 600V CC UL/CSA)
code 0001304307

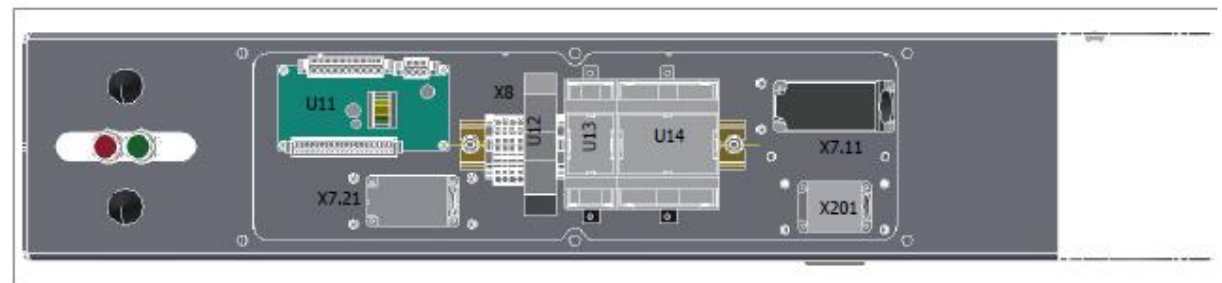
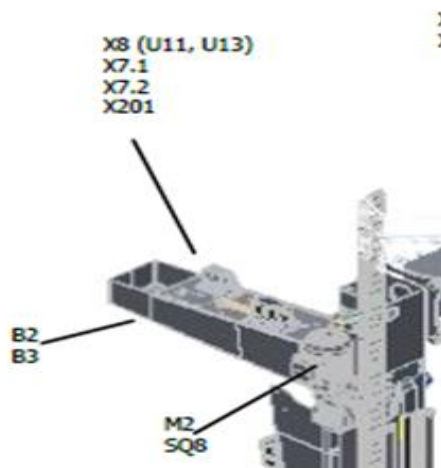
F6 - INPUT Power Supply 24VDC Fuse (10,3X38 RIT 1A 600V CC UL/CSA)
code 0001304300

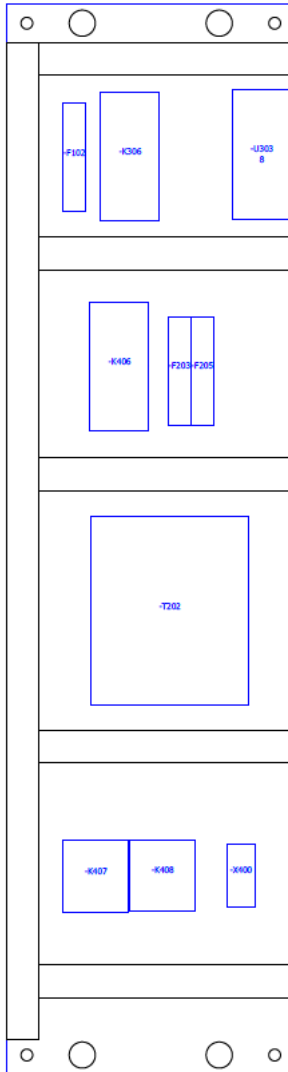


V1 Main Filter
code 00L0202680
Not provide 00L0287639 code because no UL

T0 - Power Auto-Transformer 2500VA 120/240
code 00L0198704

ELECTRICAL PANEL ON ROTATION ARM DESCRIPTION



ELECTRICAL PANEL CLUMP-CUTTER-WELDER EQUIPMENT DESCRIPTION

Power Supply Fuse **F102** 10,3x38 GG 4A 500VAC
code 0001304232

Welder Safety Contactor **K306**
code 0001357195

Welder Safety Module **U303** CS-FS-52VU24
code 00L0230421

Transformer Enable **K406**
code 0001357195

Cutting Fuse **F203** 10,3x38 GG 32A 500VAC
code 0001304238

Welder Fuse **F205** 10,3x38 GG 32A 500VAC
code 0001304238

Transformer **T202**
code 0001300895

Welder Relay **K407** NBD20024DL
code 00L0214603

Cutting Relay **K408** NBD20024DL
code 00L0214603

ELECTRONIC CARDS DESCRIPTION

PLC Main Board (U1) - - CODE 1430300238

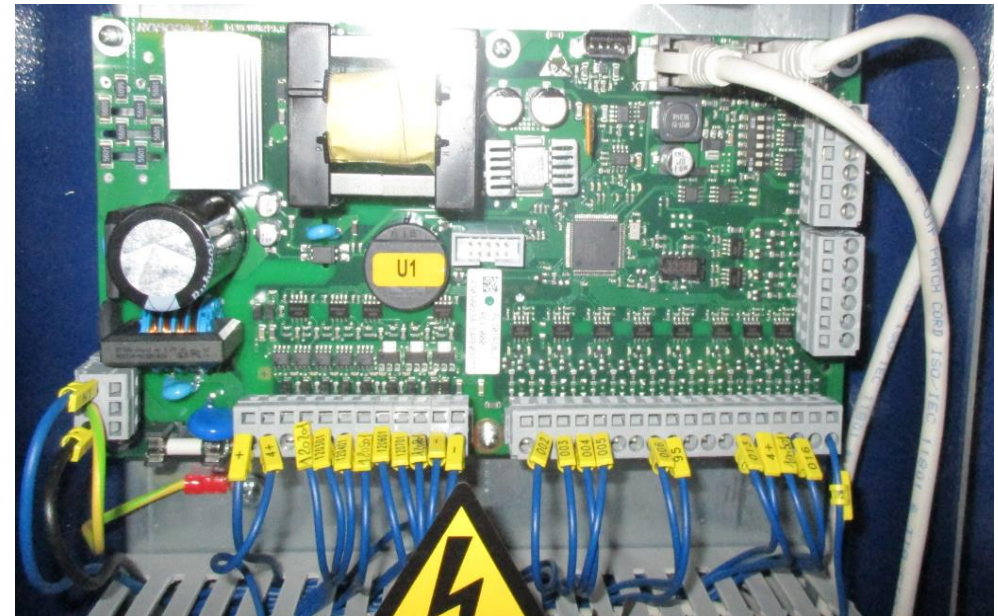
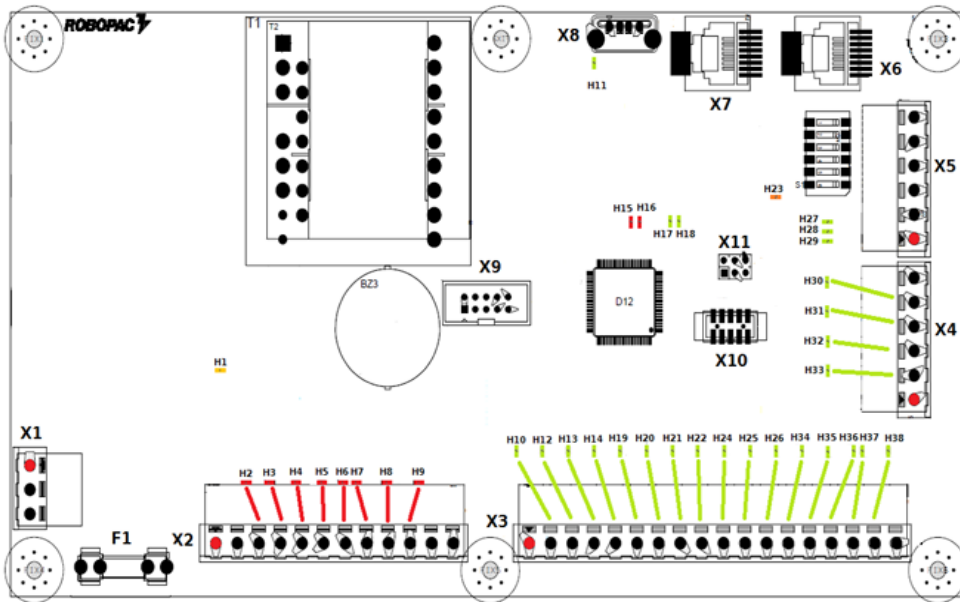


Table description U1 - Connectors and leds

X1	220Vac Power Supply
X2	Digital output terminal board (1-8)
X3	Digital input terminal board (1-16)
X4	Fast input terminal board (1-4)
X5	MB1 Communications
X6	MB2 + CAN Communications
X7	MB2 + CAN Communications
X8	USB for SW update
X9	RDMS Connector
X10	Debug
X11	ISP
H1	24V Led
H2..9	Output LED (see arrows)
H11	USB LED (blinking during programming)
H15	Start Status
H16	Error LED
H17	SUP status LED
H18	Microcontroller LED
H23	3,3V Led
H27	MB1 Led
H28	MB2 Led
H29	CAN Led
H30..33	Fast input LED (see arrows)
Hxx	Digital input LED (see arrows)

Table description status inputs – X3 Connector

Input Number	Input description	Led status	Contact type
H10	Emergency	ON	N.O.
H12	RESET	ON	N.O.
H13	START	ON	N.O.
H14	STOP	OFF	N.C.
H19	Free	OFF	N.O.
H20	Rotation Phase 2 (Optional)	ON	N.O.
H21	Rotation Phase	ON	N.O.
H22	Bumper Alarm	OFF	N.C.
H24	Free	ON	N.O.
H25	Free	ON	N.O.
H26	Free	ON	N.O.
H34	Backward Cut-Welder Arm (Only CS-CW))	ON	N.O.
H35	Safety Module	ON	N.C.
H36	Thermic relay Protection	ON	N.C.
H37	Welding emergency timer (Only CW))	ON	N.C.
H38	Remote Control Stop (Optional)	ON	N.O.

Table description status outputs – X2 Connector

Output Number	Output description
H2	Buzzer (Optional)
H3	Brake Rotation Arm Enable
H4	Forward Cut-Welder Arm Command (Optional)
H5	Closing Clamp Command (Optional)
H6	Welder Transformer Enable (Optional)
H7	Film Welder Enable (Optional)
H8	Film Cutting Enable (Optional)
H9	Opening Clamp Command (Optional)
	Exhaust Air (Optional)

Inverter Card INV01ROB_2 (T1) – CODE 1430300271

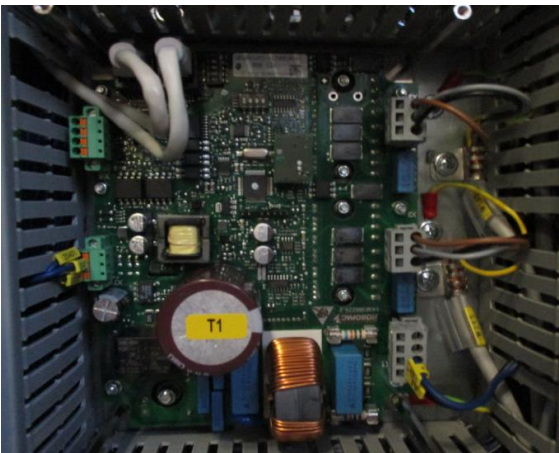
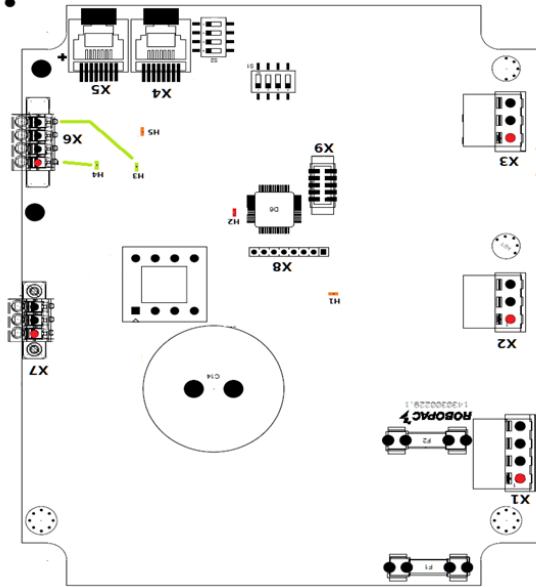
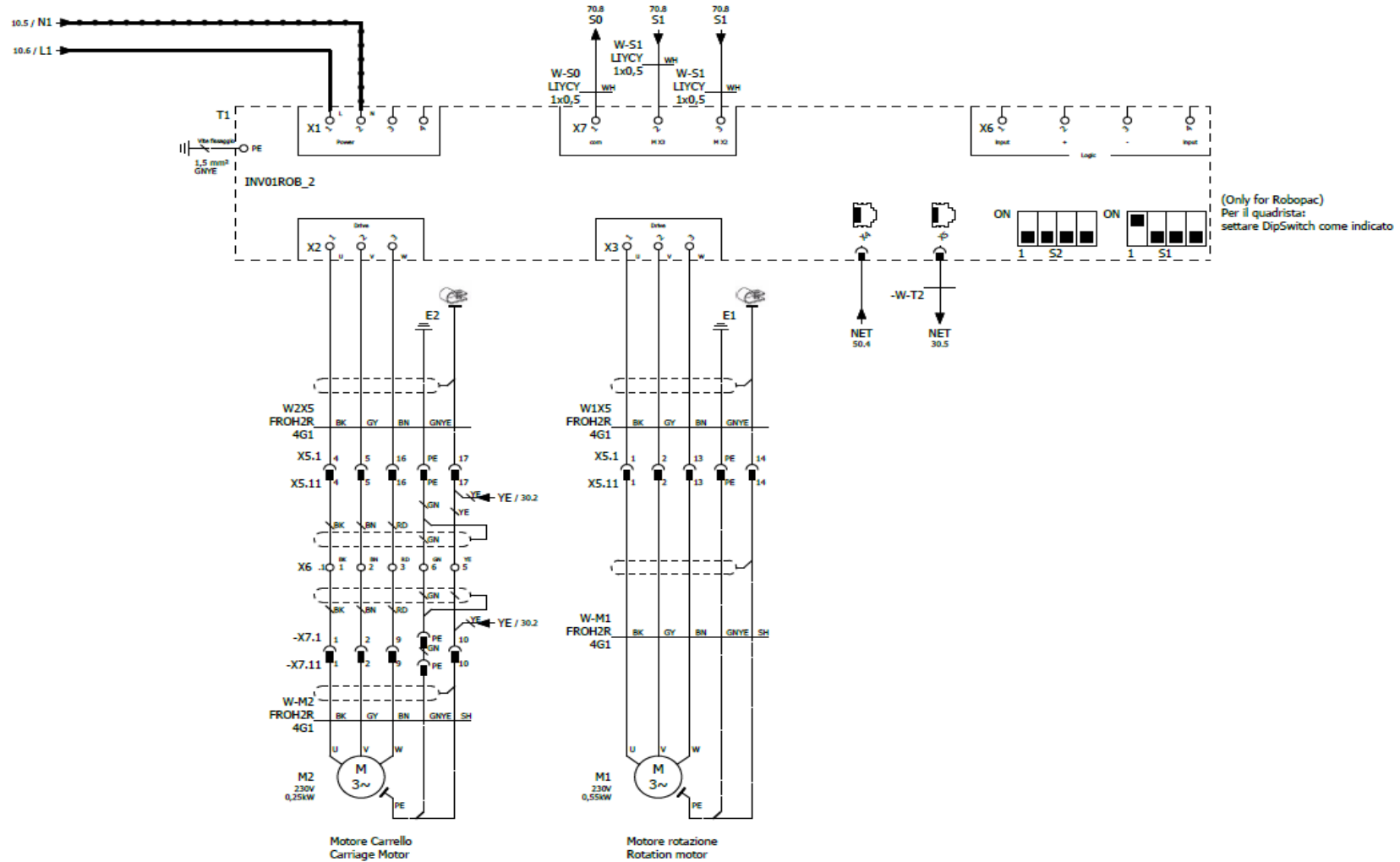


Table description: status input (T1) Arm Rotation Motor and Carriage Lift Motor

LED Number	Input description	Led Status	Contact Type
H1	230 VAC Power	ON	
H2	Error Led	1 regular blink	
H3	Input 1 on X6	OFF	N.O.
H4	Input 2 on X6	N/A	
H5	24V Modbus Power	ON	

Table description (T1): X1 – X2 – X3 – X4 – X5 – X6 – X7 – X8 – X9 Connectors

Connector Number	Description
X1	230 VAC – Card Power Supply
X2	Motor 2 – Carriage Lift
X3	Motor 1 – Arm Rotation
X4	Communication Out
X5	Communication In
X6	Digital Inputs
X7	Driver Enable
X8	SD for SW update
X9	Debug



Inverter card INV01ROB_2 (T2) – CODE 1430300271

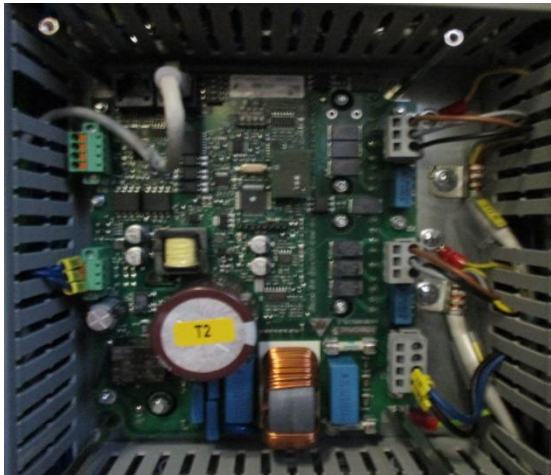
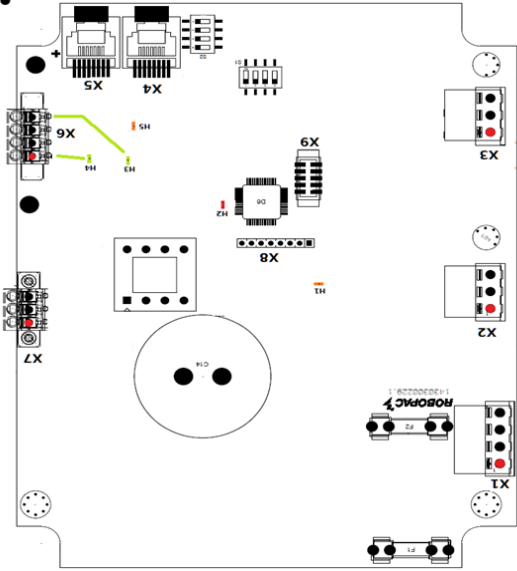
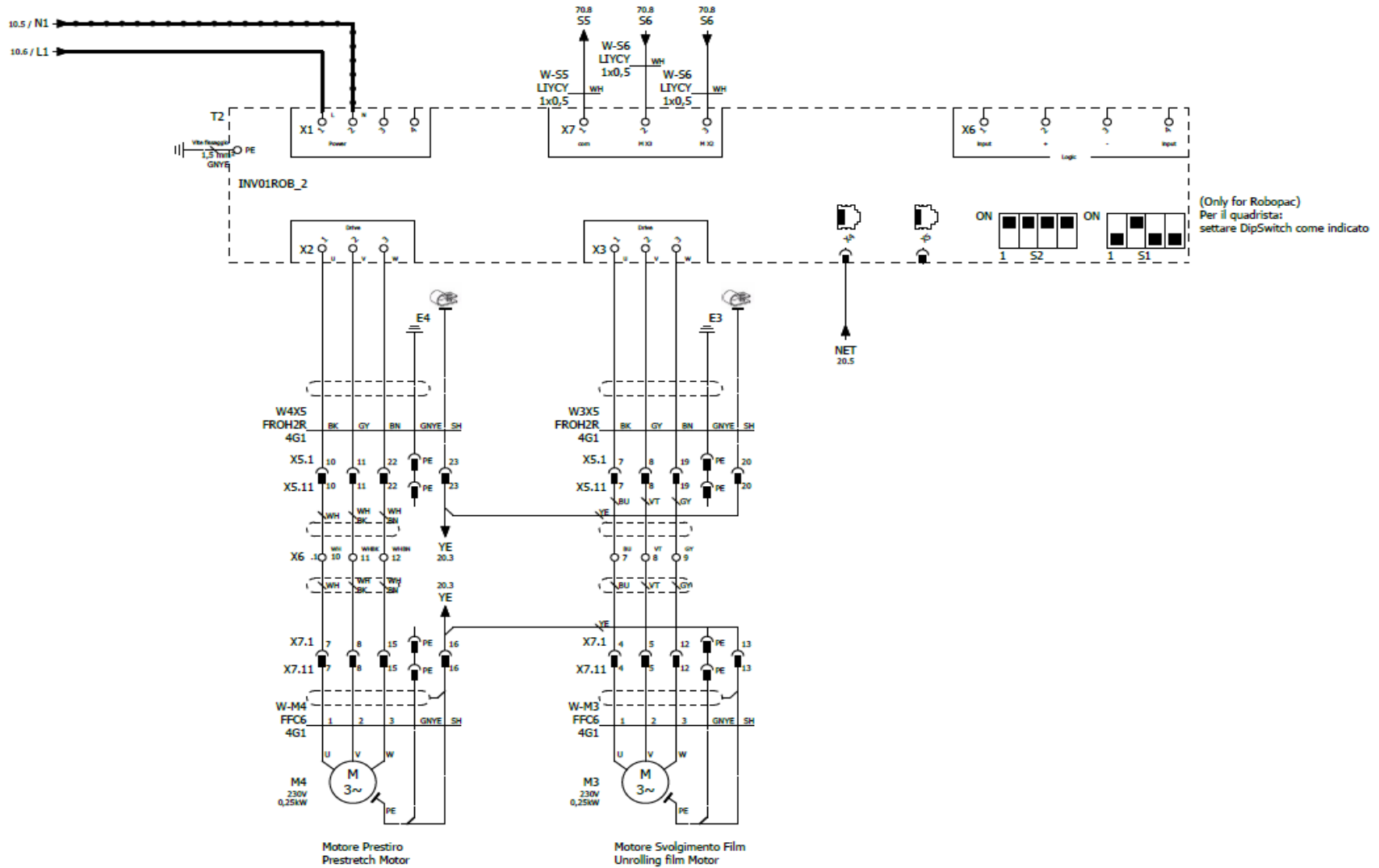


Table description status input (T2) Unrolling Film Motor and Pre-Stretch Film Motor

LED Number	Input description	Led Status	Contact Type
H1	230 VAC Power	ON	
H2	Error Led	1 regular blink	
H3	Input 1 on X6	OFF	
H4	Input 2 on X6	N/A	
H5	24V Modbus Power	ON	

Table description (T2): X1 – X2 – X3 – X4 – X5 – X6 – X7 – X8 – X9 Connectors

Connector Number	Description
X1	230 VAC – Card Power Supply
X2	Motor 4 – Pre-Stretch Film Motor
X3	Motor 3 – Unrolling Film Motor
X4	Communication Out
X5	Communication In
X6	Digital Inputs
X7	Driver Enable
X8	SD for SW update
X9	Debug



Expansion Card PRES04ROB (U11) - – CODE 1430300256

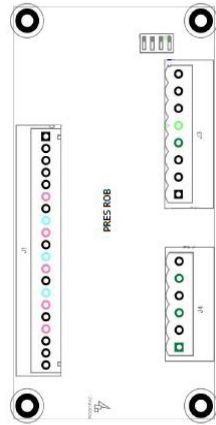
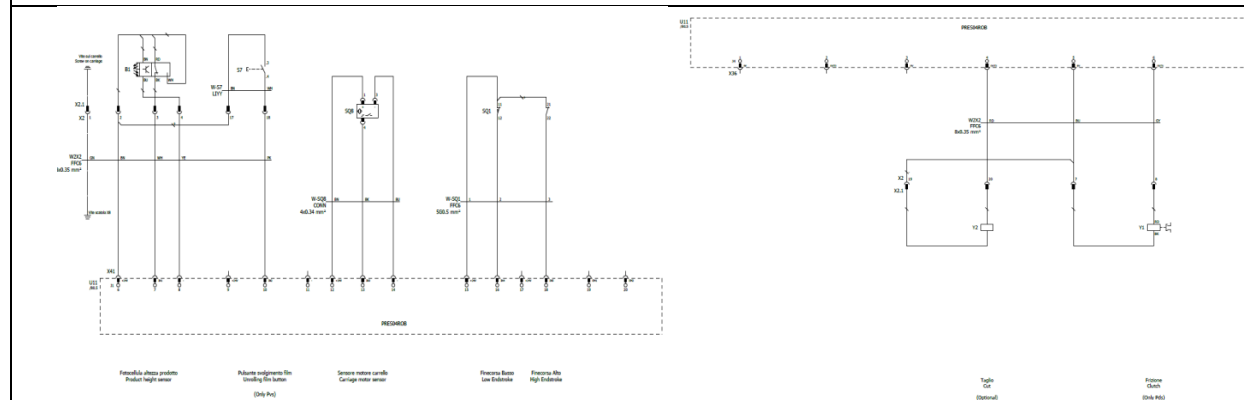
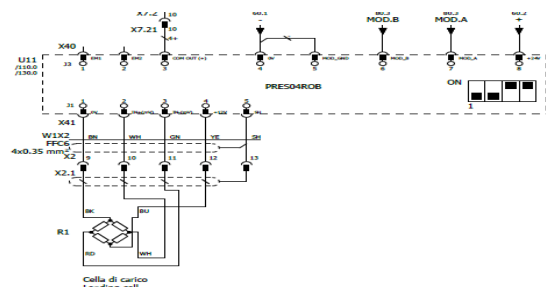


Table description status input/output (U11)

J1 Connector (Pin)	Input Description	Led Status	Contatto
+ (6)	+24 VDC		
In1 (7)	Product Height Photocell	ON	N.O.
- (8)	0 VDC		
In2 (10)	Unrolling Film Push-Button (PVS Only)	ON	N.O.
+ (12)	+24 VDC		
In3 (13)	Carriage Motor Encoder Sensor	ON	N.O.
- (14)	0 VDC		
+ (15)	+24 VDC		
In4 (16)	Low Endstroke Carriage	OFF	N.C.
In5 (18)	High Endstroke Carriage	OFF	N.C.
J4 Connector (Pin)	Output Description		
Out1 - S10 (6)	Clutch (PDS Carriage Only)		
Out2 - S11 (4)	Cuttin Film on Carriage (Optional)		

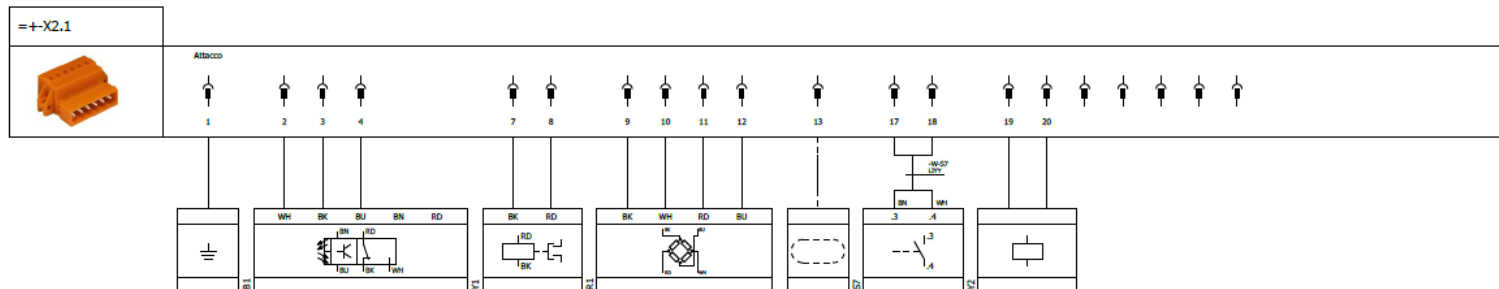
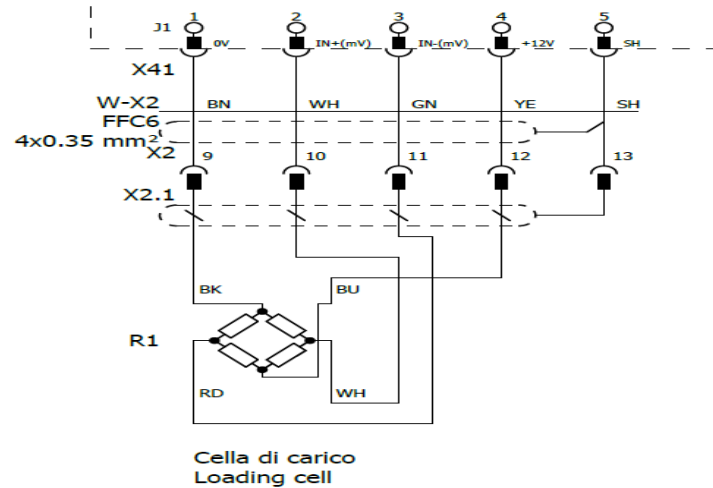
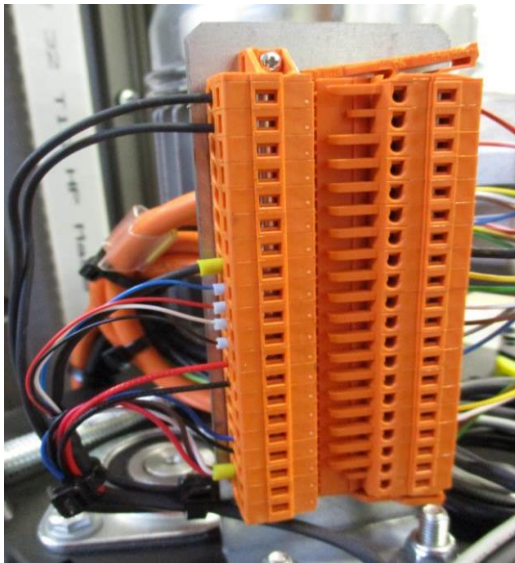
J1 Connector (Pin)	Signal Description
0V (1)	0V Load Cell Power (Black)
In+ (2)	Signal LoadCell (+ mv) (White)
In- (3)	Signal LoadCell (- mv) (Red)
12V (4)	12V Load Cell Power (Bleu)
SCH (5)	Cable shield



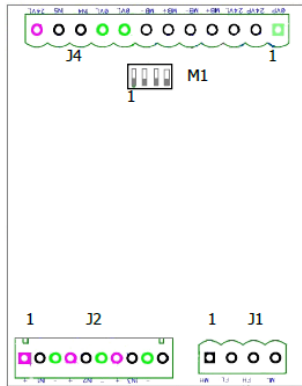
Check function of load cell (on carriage connector)

To verify the correct operation of the load cell must be checked on carriage connector , which between the Blue and Black wires of the same there are the 12 VDC representing the power.

Among White and Red wires must detect the output signal of the cell that will vary from 0 mV to 24 mV DC DC (being the ratio of 2 mV x Volt DC power supply) applying by hand a variable traction roller anchored to the cell to simulate the film's shooting.



Control Pressure Card DCM01ROB (U14) – CODE 1430300268

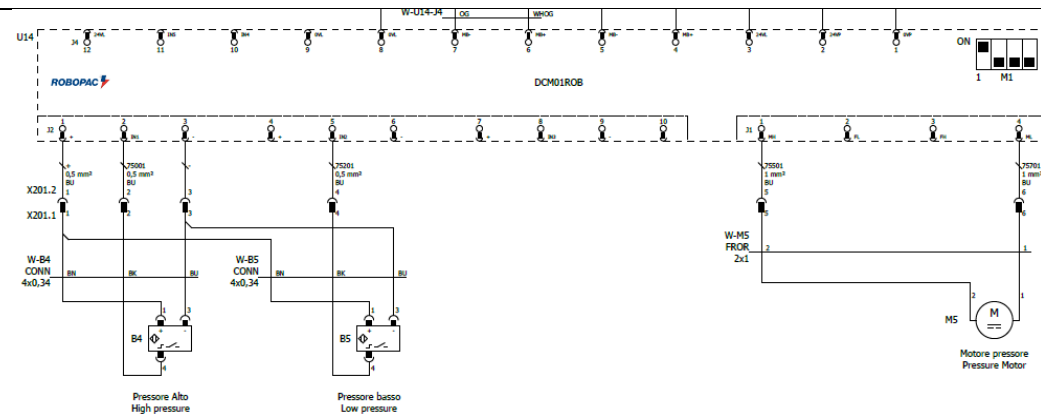


M1 Switch Configuration

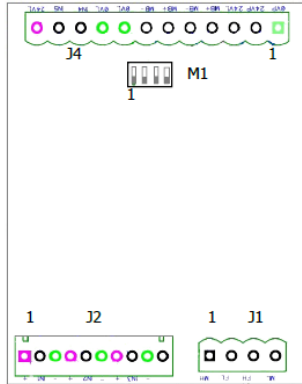


Table description status input/output (U14)

J1 Connector (Pin)	Input Description	Led Status	Contact Type
MH (1)	Pressure Motor	ON	N.O.
Libero (2)		ON	N.O.
Libero (3)		ON	N.O.
ML (4)	Pressure Motor	OFF	N.C.
J2 Connector (Pin)	Input Description		
+ (1)	Pressure Platen High Sensor		
In1(2)	Pressure Platen High Sensor	ON	N.O.
- (3)	Pressure Platen High Sensor		
+ (4)	Pressure Platen Low Sensor		
In2(5)	Pressure Platen Low Sensor	ON	N.O.
- (6)	Pressure Platen Low Sensor		



Control Roping Device Card DCM01ROB (U14) – CODE 1430300268

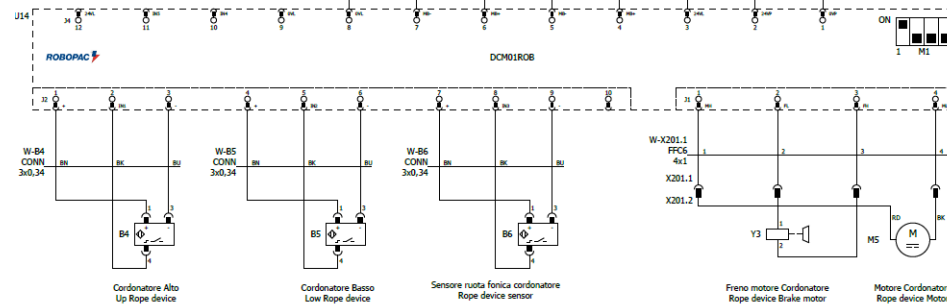


M1 Switch Configuration

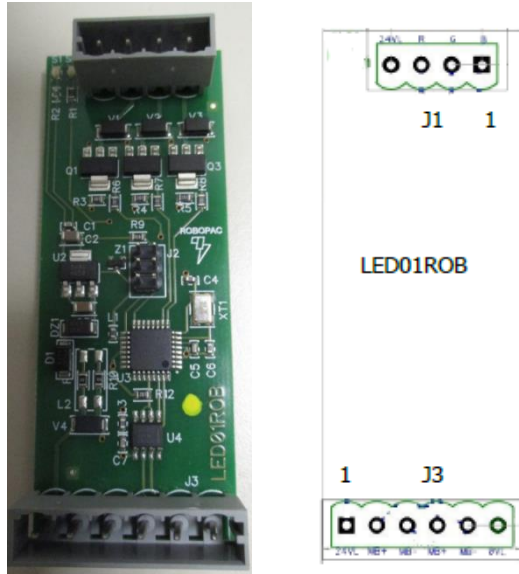


Table description status input/output (U14)

J1 Connector (Pin)	Input Description	Led Status	Contact Type
MH (1)	Roping Device Motor		
FL (2)	Brake Roping Devider		
FH (3)	Brake Roping Devider		
ML (4)	Roping Device Motor		
J2 Connector (Pin)	Input Description	Led Status	Contact Type
+ (1)	Up Sensor Roping device		
In1(2)	Up Sensor Roping device	ON	N.O.
- (3)	Up Sensor Roping device		
+ (4)	Low Sensor Roping device		
In2(5)	Low Sensor Roping device	ON	N.O.
- (6)	Low Sensor Roping device		
+ (7)	Encoder Sensor Roping device		
In3(8)	Encoder Sensor Roping device	ON	N.O.
- (9)	Encoder Sensor Roping device		



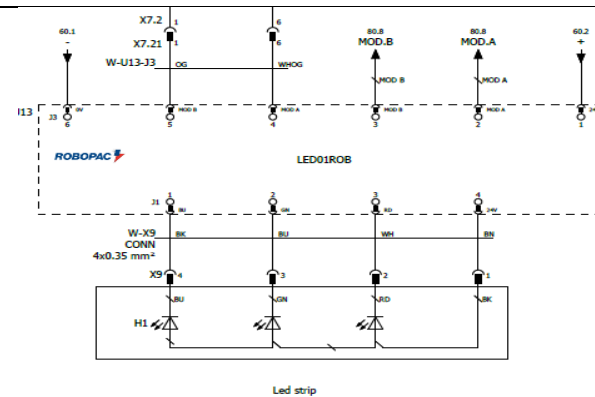
Leds Status Machine Card LED01ROB (U13) – CODE 1430300245



Led S1 – Power supply (Red Led – Continuous)
Led S2 – Modbus (Green Led – Flashing)








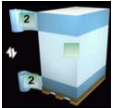


Table description function (U13)














J1 Connector (Pin)	Function description
Blu (1)	Blu Led
Green (2)	Green Led
Red (3)	Red Led
24V (4)	Common Power 24 VDC
J3 Connector (Pin)	Function description
+24V (1)	Power 24 VDC
Mod A (2)	ModBus Channel A
Mod B (3)	ModBus Channel B
Mod A (4)	ModBus Channel A
Mod B (5)	ModBus Channel B
- 0V (6)	Power 0 VDC



Led strip

LIST OF RECIPES DATA

Parameter		Min. – Max.	Step	Unit of measure / Notes		
Type of packaging cycle		Up and Down cycle				
		Up only cycle or Down only cycle				
		Top sheet cycle				
		Packaging cycle with Pressure platen		Option activation	ON BLUE COLOURED BUTTON	OFF GREY COLOURED BUTTON
		Packaging cycle with Roping unit		Option activation	ON BLUE COLOURED BUTTON	OFF GREY COLOURED BUTTON
		Packaging Cycle with cutting clamp/arm		Option activation	ON BLUE COLOURED BUTTON	OFF GREY COLOURED BUTTON
		Packaging Cycle with Welding on		Option activation	ON BLUE COLOURED BUTTON	OFF GREY COLOURED BUTTON
Bottom wraps		0 – 20	1	Wraps		
Top wraps		0 – 20	1	Wraps		
Photocell delay		0 – 50	1	cm		
Ground Offset		0 – (P5-50)	1	cm		

Reinforcement height and reinforcement wraps			20 – (P5-50)	1	cm
			0 – 20	1	Wraps
Arm Rotation speed		7 – 12		1	Rpm
Carriage up/down speed			2.5 – 5.5	0.1	m/minute
			2.5 – 5.5		
Altimeter (H Max defined to 5 Parameter)		65 – 400		1	cm
Roping Device Parameters		0 – 100		10	%
		0 - 10		1	Wraps
Cutting time			0.1 – 10.0	0.1	Sec.
Welding time		0.1 – 10.0		0.1	Sec.

FR CARRIAGE (Rotary – Rototech 308)

Film Drive		0 – 100	1	Dimensionless
------------	--	---------	---	---------------

PDS CARRIAGE (Rotary – Rototech 508)

Film Drive		0 – 100	1	Dimensionless
Film pre-stretch		0 -- 25	10	%



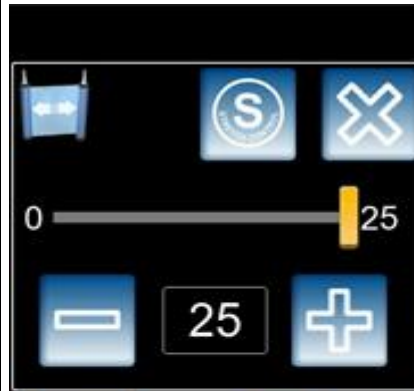
Stretch control off.

Pre-stretch is not a variable but always set to maximum. The obtained pre-stretch depends on the gear ratio applied on the carriage (200% - 250% - 300%).

Standard operations includes 250% maximum applied pre-stretch.

While pressing for about 4 sec.

the icon enables the management of the shot into 4 values (Bottom wraps – Carriage up - Top wraps – Carriage down)

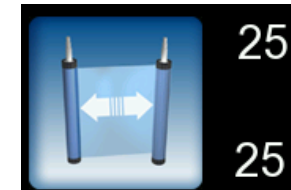


Stretch control on.

It's possible to DEACTIVATE the prestretch. With values from 0 to 6/7/8/9 (it depends on many elements) the prestretch is DEACTIVATED, with values over that value the Prestretch is ACTIVATED. The obtained pre-stretch depends on the gear ratio applied on the carriage (200% - 250% - 300%). Standard operations includes 250% maximum applied pre-stretch.

While pressing for about 4 sec.

the icon enables the management of the pre-stretch into 2 values (Carriage up – Carriage down)





Norm. Tecn.
60.2.66_08

TECHNICAL DOCUMENTATION
ROTARY-ROTOTECH



Date:
November 2021






Rev.12

ENGLISH

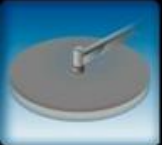



Pag. 34 / 100

PVS CARRIAGE (Rotary – Rototech 708)

Film Drive		0 – 100	1	Dimensionless
Film pre-stretch		150 -- 400	10	%

 → 	<p>Enabling Special packaging cycles</p> <ul style="list-style-type: none"> DISABLED FUNCTION → ICON GREY BACKGROUND. 		<p>Cycle standard packing with bottom wraps at end of cycle (SPECIAL CYCLE DISABLED – icon background color gray)</p>
	<ul style="list-style-type: none"> FUNCTION ENABLED ICON BACKGROUND BLUE 		<p>Special cycle for packaging products with bottom wraps at the start of cycle (SPECIAL CYCLE ENABLED – icon background color blue)</p>

MACHINE OPTIONS

Optional function	Description	Mechanical settings	Electrical settings	Pneumatic settings
	Mechanical pressure platen	✓	✗	N/A
	Roping Device Unit	✓	✗	✗
	Clamp and Cutting Unit	✓	✗	✗
	Welding Unit	✓	✗	✗

OPERATOR PANEL PASSWORD USE

Proceed as follows to change the operator panel password:



From the main page (the one that appears when the machine is turned on), press the "TOOLS" icon.



In the applications page, press the "ACCOUNT" icon.



In the account page, press the "USER" icon until the required user icon is displayed (see specifications below). Press the button to confirm

Default "CUSTOMER USER" password reset procedure (factory settings).











If the first level password is lost (**CUSTOMER USER operator**), the default password can be reset (**1111**).

Open the RESET page and press the four corners of the TOUCH screen operator panel, starting from the top left in counter-clockwise order, within 5 seconds. When finished, the panel will beep and display a key for several seconds. The new default password (**1111**) will appear to confirm the new settings..













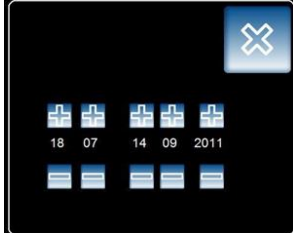


The key with password **1111** appears on the touch screen panel display to confirm that the password was reset to DEFAULT

Enter the new password and press ENT. The new password is displayed in the image below (example 2222). Press the green button to confirm changes or press the red button to keep the current password.

MACHINE USER CUSTOMER SELECTION	  <p>No access password to higher use levels. Touch-screen operator panel locked..</p>	 <p>Machine use for packaging.</p>
	  <p>CUSTOMER USER (Machine manager/User) Enter password = 1111</p>	
<p>Utilizzo della macchina limitato alla impostazione dei valori di ciclo ed impostazione di una diversa password di accesso.</p>		
ROBOPAC DEALER SECTION	  <p>MAINTENANCE TECHNICIAN USER (Robopac dealer) Password = 6161</p>	 <p>Maintenance technician password accepted confirmation.</p>
<p>Possibilità di utilizzo della macchina come "Utente cliente" ed accesso alle funzioni ed alla diagnostica per la manutenzione.</p>		
ROBOPAC SECTION	 <p>ROBOPAC TECHNICIAN USER For exclusive ROBOPAC technician use</p>	 <p>ROBOPAC technician password accepted confirmation.</p>

INITIAL TOUCH SCREEN PANEL SETTINGS (ROBOPAC USE ONLY)

	<p>Press the configuration button</p>		
	<p>Insert the USB key containing file erw0.erp in the panel (in the Robopac access EXMEM folder). Press the user key until the user with the Robopac symbol appears</p>		
	<p>Enter password 3333 and press  Enter</p> <p>The correct password is confirmed by the user image with the Robopac "lightening bolt" in the tool bar.</p>		
	<p>Press the HMI key</p>		
	<p>Press the date and time settings key</p> <p>Set the time and date and press the close key  followed by the  HOME key</p>		

VARIOUS TOUCH SCREEN OPERATOR PANEL FUNCTIONS

HMI Setting

Press the "Beeper" key to turn off panel key touch beep.



Press the padlock key to lock/unlock program editing by the base operator.



Press the flag key to change the panel display language



SW / HW Information

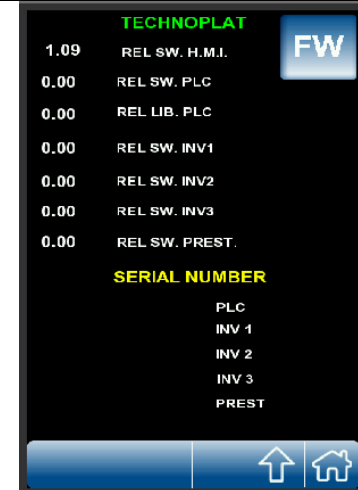
Press the info key.



The screen displays the PLC software (SW + library), 3 inverters (main, carriage and pressure platen) and touch screen panel versions.

Press the FW key to display touch screen panel version details at the bottom.

Hardware version 0
Kernel version 0
Rootfs version 0



Counter Reset

Press the reset key to the left of the 'Total' to reset all screen values.

The reset key to the left of 'Partial' ONLY resets the partial counter.



CONTATORI

- 0 Totale
- 0 Parziale
- 0 Total wrapp. height (cm)
- 0 Time Run (h)
- 0 CNT Fungo
- 0 CNT Emerg. Bump
- 0 CNT Rott Film
- 0 Time Alarm (h)
- 0 Time Wait (h)
- 0 Last Sent
- 0 Film Consumption (dm)





Norm. Tecn.
60.2.66_08

TECHNICAL DOCUMENTATION
ROTARY-ROTOTECH

Date:
November 2021

Rev.12

ENGLISH

Pag. 40 / 100

MACHINE CONFIGURATION AND INTERNAL PARAMETER LIST

To edit the parameters in the list below, we suggest you contact a Robopac technician

Machine Configuration Parameters

PARAMETER	DESCRIPTION	VALUE	PDS 508 (DEF)	FR 308	PVS 708
P1	Carriage Type	2 = 308 FR 4 = 508 PDS 5 = 708 PVS	4	2	5
P2	Cutting Type	0 = not cuto 1 = Cut on carriage 2 = CS (Cut and Spalming) 3 = CW (Cut and Welding)	0	0	0
P3	Film Brake Alarm On	0-1	1	0	1
P4	Reel Height (mm) It's the dimension of the film SPOOL	0 = 500 mm 1 = 750 mm	0	0	0
P5	Maximum adjustable height as an altimeter in cm	200 cm – 400 cm	215	215	215
P6	Enable U.S.A. display	0-1	0	0	0
P7	Enable Optional Unit function	0 = not optional Unit 1 = Roping Device 2 = Pressure Platen	0	0	0
P8	final ascent of the carriage (cm) (CS-CW only).	0-100	7	7	7
P9	Film stretch during cutting	0-100	20	20	20
P10	Tail length film upon cutting (mm)	0-300	60	60	60
P11	Homepage (page number used as homepage)	10-18	10	10	10
P12	Down-ward distance spool carriage for top sheet cycle (cm)	0-200	50	50	50
P13	Not used				

P14	Stretch Value in the final part of the cycle (PDS only)	0-100	0	0	0
P15	Not Used				
P16	K_GAIN Never change, inside software parameter	0-200	130	130	118
P17	K_TMIN (Minimum Drive) Never change, inside software parameter	0-200	30	30	10
P18	K_PMIN (Costant pre-stretch) Never change, inside software parameter	0-200	30	30	30
P19	Enable Simulation	0-1	0	0	0
P20	Max Cell Drive Changing in load cell sensibility, high value – high sensibility, low value – low sensibility	0-100	15	15	32
P21	Not Used				
P22	Maximum friction voltage (FR) Maximum value of the clutch in FR carriage (50 = 12 VDC, 100 = 24VDC)	0-100	50	50	50
P23	Pre-stretch value (Only PDS)	0=150% 1=200% 2=250% 3=300%	2	2	2
P24	Not Used				
P25	Not Used				
P26	Restart Time	0 = Disattivato xx = secondi attesa	0	0	0
P27	Not Used				
P28	Enable Protection	0-1	0	0	0
P29	Safety Door	0-1	0	0	0



Norm. Tecn.
60.2.66_08

TECHNICAL DOCUMENTATION
ROTARY-ROTOTECH

Date:
November 2021

Rev.12

ENGLISH

Pag. 42 / 100

P30	FN Enable Special Cycles	0-1	0	0	0
P31	P-KP1	0-500	0	0	0
P32	P-KI1	0-500	0	0	0
P33	P-KP2	0-500	0	0	0
P34	P-KI2	0-500	0	0	0
P35	P-KPID	0=New PID, 1=Old PID	1# / ##	1##	1##
P36	Air blow height Height for air blow stop	0-100 cm	35	35	35
P37	Enable MLC Enabling of the Multi Layer Control	1 = Robopac	1	1	1
P38	Not Used				
P39	Not Used				
P40	Not Used				

DEFAULT is **1** for machines produced up to July 2018, DEFAULT is **0** for machines produced from July 2018 – serial number 30171045 -
the value has to be **1** for machines produced up to July 2018, and **0** for machines produced from July 2018 – serial number 30171045 -



Norm. Tecn.
60.2.66_08

TECHNICAL DOCUMENTATION
ROTARY-ROTOTECH

Date:
November 2021

Rev.12

ENGLISH

Pag. 43 / 100

Machine Configuration Parameters *(from Software Pack 118.4.2 OCTOBER 2018)*

PARAMETER	DESCRIPTION	VALUE	PDS 508 (DEF)	FR 308	PVS 708
P1	Carriage Type	2 = 308 FR 4 = 508 PDS 5 = 708 PVS	4	2	5
P2	Cutting Type	0 = not cuto 1 = Cut on carriage 2 = CS (Cut and Spalming) 3 = CW (Cut and Welding)	0	0	0
P3	Film Brake Alarm On	0 = allarme disable 1 = allarme with only load cell 2 = allarme with film consumption roll 3 = allarme with load cell and roll	1	0	1
P4	Reel Height (mm) It's the dimension of the film SPOOL	0 = 500 mm 1 = 750 mm	0	0	0
P5	Maximum adjustable height as an altimeter in cm	200 cm – 300 cm	215	215	215
P6	Enable U.S.A. display	0-1	0	0	0
P7	Enable Optional Unit function	0 = not optional Unit 1 = Roping Device 2 = Pressure Platen	0	0	0
P8	final ascent of the carriage (cm) (CS-CW only).	0-100	12	12	12
P9	Film stretch during cutting	0-100	20	20	20
P10	Tail length film upon cutting (mm)	0-300	60	60	60
P11	Homepage (page number used as homepage)	10-18	10	10	10
P12	Down-ward distance spool carriage for top sheet cycle (cm)	0-200	50	50	50
P13	Roping angle	0-345	0	0	0

P14	Stretch Value in the final part of the cycle (PDS only)	0-100	0	0	0
P15	Not Used				
P16	K_GAIN Never change, inside software parameter	0-200	118	118	118
P17	K_TMIN (Minimum Drive) Never change, inside software parameter	0-200	35	35	25
P18	K_PMIN (Costant pre-stretch) Never change, inside software parameter	0-200	2	2	2
P19	Enable Simulation	0-1	0	0	0
P20	Max Cell Drive Changing in load cell sensibility, high value – high sensibility, low value – low sensibility	0-100	39	39	39
P21	Not Used				
P22	Maximum friction voltage (FR) Maximum value of the clutch in FR carriage (50 = 12 VDC, 100 = 24VDC)	0-100	50	50	50
P23	Pre-stretch value (Only PDS)	0=150% 1=200% 2=250% 3=300%	2	2	2
P24	Not Used				
P25	Not Used				
P26	Restart Time	0 = Disattivato xx = secondi attesa	0	0	0
P27	Not Used				
P28	Enable Protection	0-1	0	0	0
P29	Safety Door	0-1	0	0	0



Norm. Tecn.
60.2.66_08

TECHNICAL DOCUMENTATION
ROTARY-ROTOTECH

Date:
November 2021

Rev.12

ENGLISH

Pag. 45 / 100

P30	FN Enable Special Cycles	0-1	0	0	0
P31	P-KP1	0-500	50	50	50
P32	P-KI1	0-500	25	25	25
P33	P-KP2	0-500	0	0	0
P34	P-KI2	0-500	0	0	0
P35	P-KPID	0=New PID, 1=Old PID	1# / ##	1##	1##
P36	Air blow height Height for air blow stop	0-100 cm	35	35	35
P37	Enable MLC Enabling of the Multi Layer Control	1	1	1	1
P38	Not Used				
P39	Not Used				
P40	Not Used				

DEFAULT is **1** for machines produced up to July 2018, DEFAULT is **0** for machines produced from July 2018 – serial number 30171045 -
the value has to be **1** for machines produced up to July 2018, and **0** for machines produced from July 2018 – serial number 30171045 -



Norm. Tecn.
60.2.66_08

TECHNICAL DOCUMENTATION
ROTARY-ROTOTECH

ENGLISH

Date:
November 2021

Rev.12

Pag. 46 / 100

To edit the parameters in the list below, we suggest you contact a Robopac technician

Motors Parameters

PARAMETER	DESCRIPTION	VALUE	DEFAULT VALUES			
			ARM ROTATION	CARRIAGE LIFT	FILM DRIVE	FILM PRE-STRETCH
1	FW version					
2	Bootloader version					
3	Minimum frequency	0-20 (Hz)	0	0	0	0
4	Maximum frequency	0-100 (Hz)	90	90	100	100
5	Acceleration	0-999 (Hz/sec)	7	25	170	170
6	Deceleration	0-999 (Hz/sec)	12	200	170	170
7	Maximum current	0-10 (A)	7	5	5	5
8	Average current	0-100 (dA)	50	25	25	25
9	Rated frequency	0-100 (Hz)	50	72	72	72
10	Boost voltage	0-100 (%)	10	20	5	5
11	Point 1 frequency	0-100 (Hz)	10	10	10	10
12	Point 1 voltage	0-100 (%)	20	25	16	16
13	Motor type	0-5	0	0	0	0
14	Positioning on	0-1	0	1	0	0
15	I Max Low Frequency	0-100	50	25	25	25
16	Feedback Value	0-6	0	1	0	0
17	Early low speed	0-999	0	35	0	0
18	Low speed value	0-999 (dHz)	50	220	50	50
19	Fast deceleration (Hz/sec)	0-999 (Hz/sec)	200	65	65	65
20	Communication Timeout	0-100 (ms)	30	30	30	30

To 750 carriage PVS USA modify the following parameters of the lift motor:

P4 = 85 , P5 = 25, P6 = 400, P8 = 30. P10 = 35, P11 = 25, P12 = 40, P15 =30

PROCEDURE FOR REPLACING, LOADING SOFTWARE AND CALIBRATION OF ELECTRONIC CARDS

TOUCH SCREEN PANEL (U9)

In case you need to perform a software update on both touch screen panel (HMI) and the PLC card, you must always start from the download of the panel software.



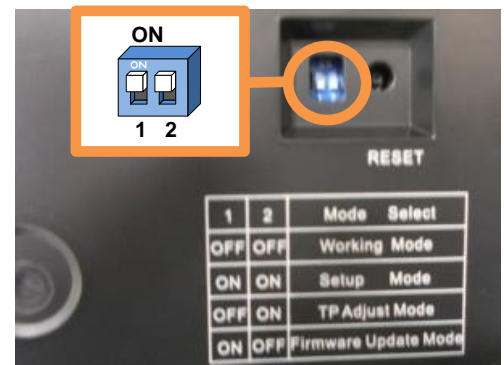
New installation MT4414TE-RO KINCO --- till January 2021 CODE : 1490300020


The new Touch Screen panel is supplied as a spare part WITHOUT software

- Mount mechanically the new touch-screen panel in place of the faulty part.
- Wire electrically the new touch-screen panel.
- Switch on the machine

Install the touch-screen panel software by following this procedure:

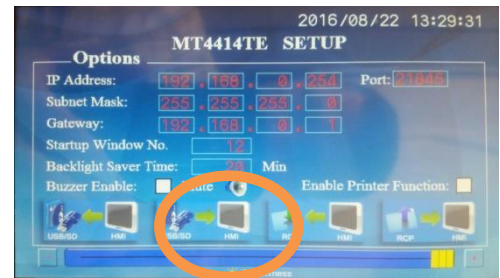
Set the dip switches 1 and 2 to ON to enable the Setup Mode, then press the RESET pushbutton



 Norm. Tecn. 60.2.66_08	TECHNICAL DOCUMENTATION ROTARY-ROTOTECH	Date: November 2021	Rev.12
	ENGLISH	Pag. 48 / 100	

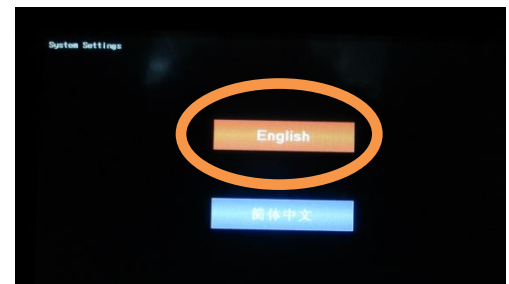
(Old bootloader Kinco Panel)


On the HMI screen, press the “USB/SD → HMI” button to open the file manager:

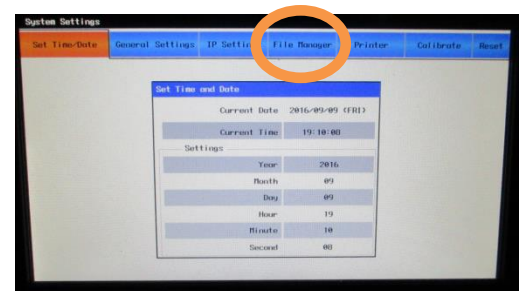


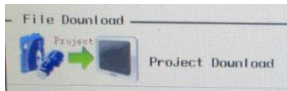
(New bootloader Kinco Panel)

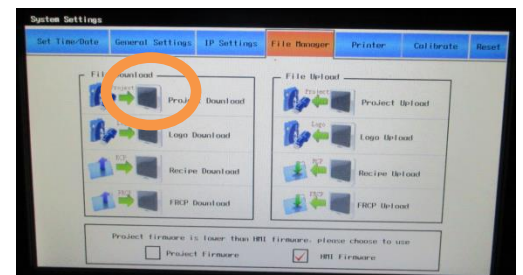
On the HMI screen, press  button to open the System Setting.



From the System Setting page, press the button 



From the File Manager page, press the button  to open the page copy of the file:



Retrieve the USB pen drive containing the original software versions which is supplied with the machine.



Robopac provides the original machine software with the USB 2.0 pen drive housed in the switchboard with all the technical machine documentation.

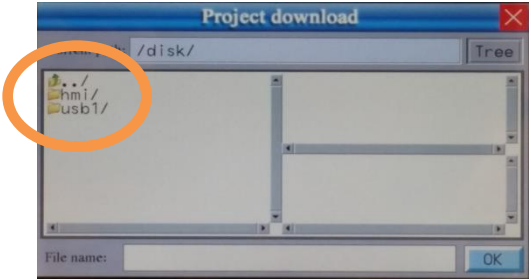
N.B.: In case it's necessary to create a new installation support (e.g: the original pen drive is lost) with a commercial pen drive:

- use a USB 2.0 pen drive only
- copy the PLC board software files provided by Robopac at first directory level of pen drive

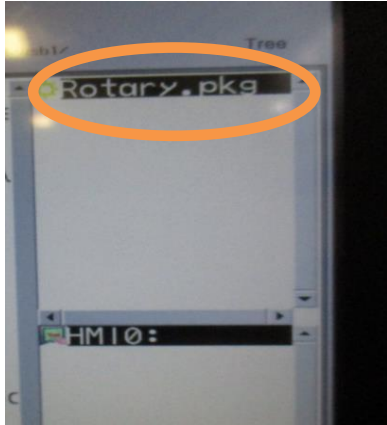
Insert the USB pen drive containing the original software version (file named ROTARY.pkg) into USB plug (USB HOST) of the touch-screen panel.



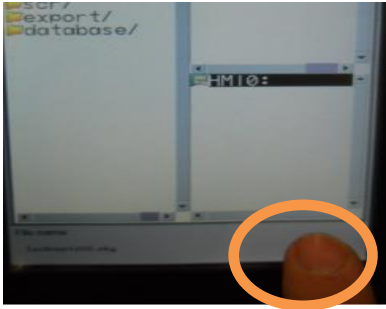
On the left screen side, press 'usb1 /'.



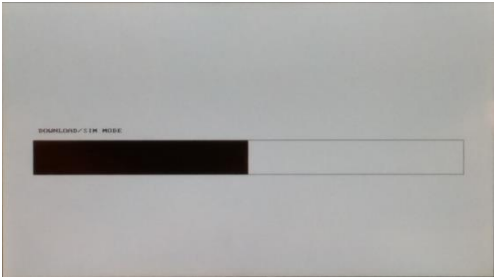
On the right screen side, select the file "ROTARY.pkg".



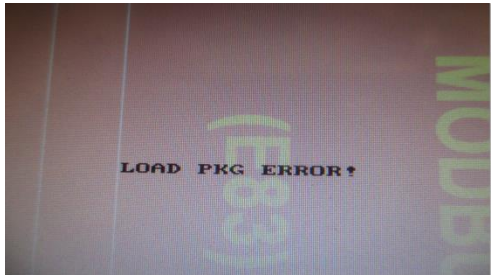
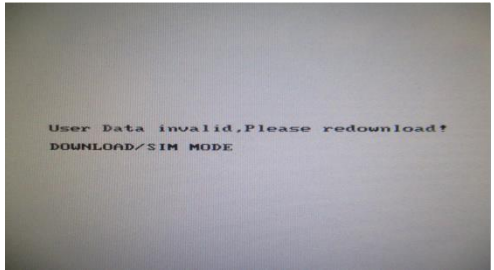
Press the OK button



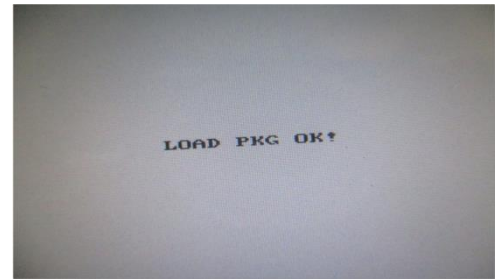
Wait for the end of the procedure



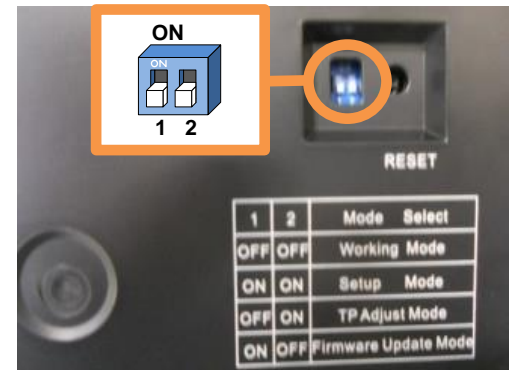
If at the end of the procedure the following messages appear loading has failed and must repeat the procedure as if you were installing a new panel.



If at the end of the procedure the following message loading was successful

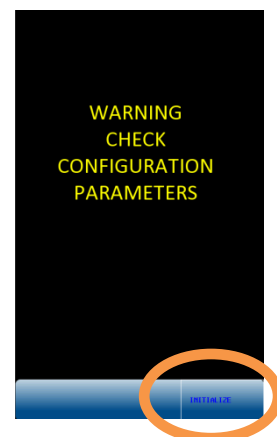


When the loading is complete, enable the Working Mode by putting the dip switches 1 and 2 to OFF, then press the RESET pushbutton.




If the panel is not initialized (update of previous software release) the warning page shown aside could appear. In this case, press the "INITIALIZE" button (at the lower right corner) to initialize the HMI, then turn off and on the machine. The warning window should no longer appear (HMI correctly initialized).

If the warning window doesn't appear, go ahead and press the RESET button.



The software installation procedure is now complete.

It's now necessary to run the **Default Parameters** and configuration of machine parameters and **Default Recipes** (see procedures) to fully restore the machine operation.

 Norm. Tecn. 60.2.66_08	TECHNICAL DOCUMENTATION ROTARY-ROTOTECH	Date: November 2021	Rev.12
	ENGLISH	Pag. 52 / 100	

New installation K-GL070E-RO KINCO --- since January 2021

CODE : 1490300034

The new Touch Screen panel is supplied as a spare part WITHOUT software

- Mount mechanically the new touch-screen panel in place of the faulty part.
- Wire electrically the new touch-screen panel.

Install the touch-screen panel software by following this procedure:

Retrieve the USB pen drive containing the original software versions which is supplied with the machine.




Robopac provides the original machine software with the USB 2.0 pen drive housed in the switchboard with all the technical machine documentation.

N.B.: In case it's necessary to create a new installation support (e.g: the original pen drive is lost) with a commercial pen drive:

- use a USB 2.0 pen drive only
- copy the PLC board software files provided by Robopac at first directory level of pen drive

Insert the USB pen drive containing the original software version (file named ROTARY.pkg) into USB plug (USB HOST) of the touch-screen panel

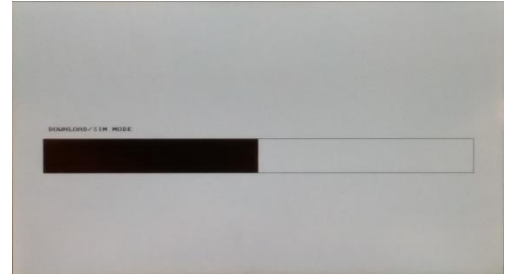


 Norm. Tecn. 60.2.66_08	TECHNICAL DOCUMENTATION ROTARY-ROTOTECH	Date: November 2021	Rev.12
	ENGLISH	Pag. 53 / 100	

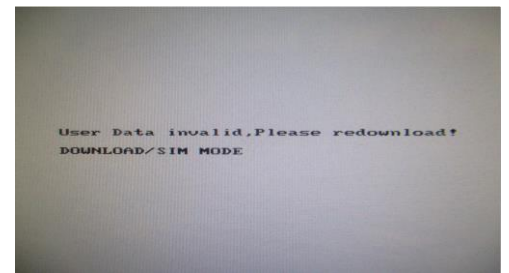
Switch on the machine

THE DOWNLOAD PROCEDURE IS AUTOMATIC

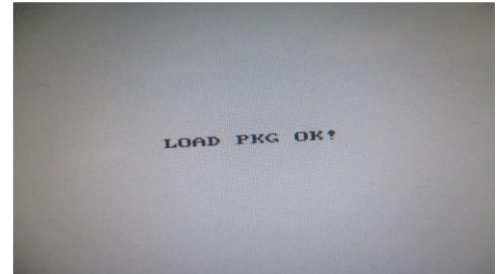
Wait for the end of the procedure



If at the end of the procedure the following messages appear loading has failed and must repeat the procedure as if you were installing a new panel.

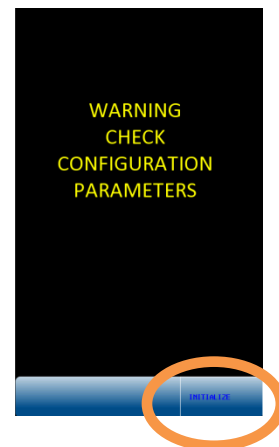


If at the end of the procedure the following message loading was successful




If the panel is not initialized (update of previous software release) the warning page shown aside could appear. In this case, press the "INITIALIZE" button (at the lower right corner) to initialize the HMI, then turn off and on the machine. The warning window should no longer appear (HMI correctly initialized).

If the warning window doesn't appear, go ahead and press the RESET button.



The software installation procedure is now complete.

It's now necessary to run the **Default Parameters** and configuration of machine parameters and **Default Recipes** (see procedures) to fully restore the machine operation.

 Norm. Tecn. 60.2.66_08	TECHNICAL DOCUMENTATION ROTARY-ROTOTECH	Date: November 2021	Rev.12
	ENGLISH	Pag. 54 / 100	

Software update

With the machine switched on, insert the USB pen drive containing the updated version of the panel software (file name: "ROTARY.pkg") into the USB port ("USB HOST") of the touch-screen panel.




On startup screen, press the "Configuration" button:



On Configuration page, press the "Service" button:

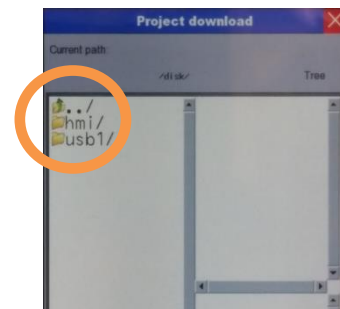


 Norm. Tecn. 60.2.66_08	TECHNICAL DOCUMENTATION ROTARY-ROTOTECH	Date: November 2021	Rev.12
	ENGLISH	Pag. 55 / 100	

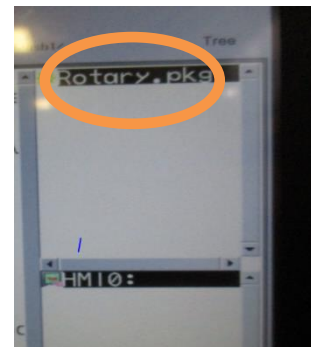
On Service page, press the “Download”  button to open the file manager:



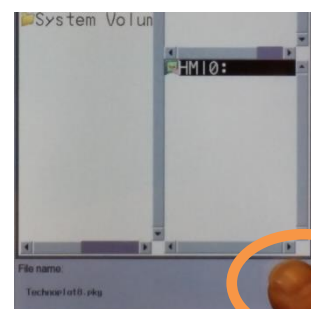
On the file manager left panel, press “usb1”.



On the file manager right panel, select the file “ROTARY.pkg”.




Press the “OK” button and wait until the software update ends.

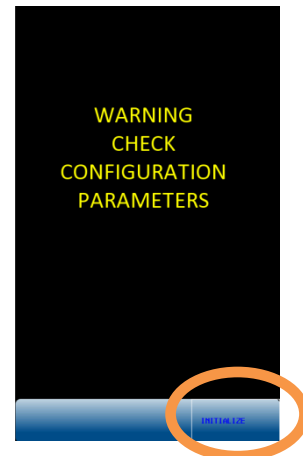


When loading ends, a communication error page could appear. Switch off and on the machine to reinitialize the communication and cancel the error.




 Norm. Tecn. 60.2.66_08	TECHNICAL DOCUMENTATION ROTARY-ROTOTECH	Date: November 2021	Rev.12
	ENGLISH	Pag. 56 / 100	

If the panel is not initialized (update of previous software release) the warning page shown aside could appear. In this case, press the "INITIALIZE" button (at the lower right corner) to initialize the HMI, then turn off and on the machine. The warning window should no longer appear (HMI correctly initialized).
If the warning window doesn't appear, go ahead and press the RESET button.



It's now necessary to run the **Default Parameters** and configuration of machine parameters and **Default Recipes** (see procedures) to fully restore the machine operation.

 Norm. Tecn. 60.2.66_08	TECHNICAL DOCUMENTATION ROTARY-ROTOTECH	Date: November 2021	Rev.12
	ENGLISH	Pag. 57 / 100	

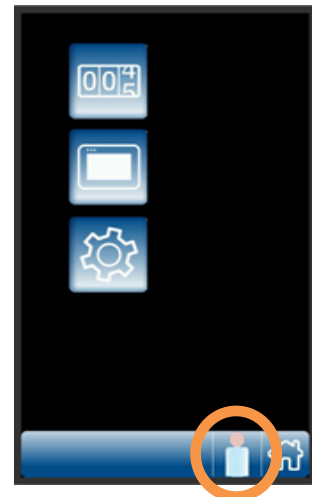
Default Parameters and re-configuration of machine parameters

After the software installation on touch screen panel (USB HOST), it's necessary to execute the "Machine Parameters Default" by following this procedure:

On startup screen press the Configuration button 



On Configuration page press the user password selection button.



Select the "maintenance technician" user level by pressing the user icon

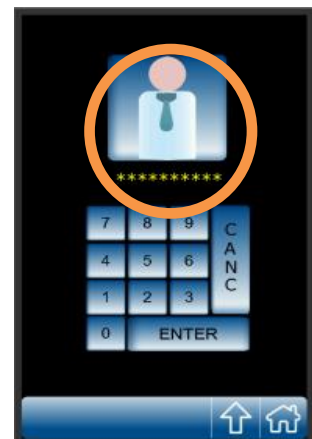


until the icon



appears.

Now, on the onscreen keyboard enter the password **6161**, then press .



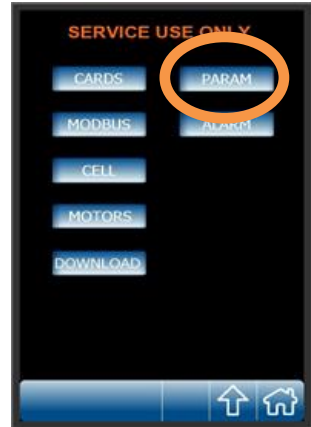
If the password is correctly entered and accepted, the Configuration page returns, with the “maintenance technician” icon on the bottom status bar.



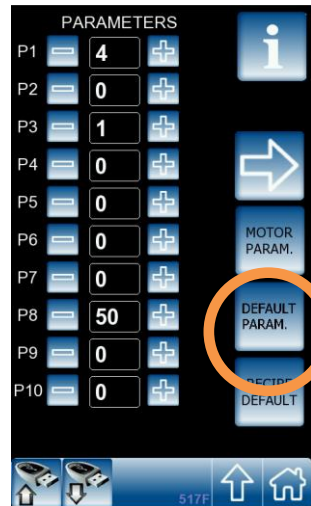
Press now the Service button:



On “Service” page, press the “PARAM” button to enter the Page 1 of Machine Parameters.

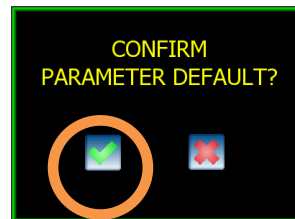




Press the button to start the procedure for setting all machine parameters with their default values.




Confirm with the green button to complete the **Parameters Default** procedure. In this way, the Parameters Default is performed.


Press the red button to abort the **Parameters Default** procedure.

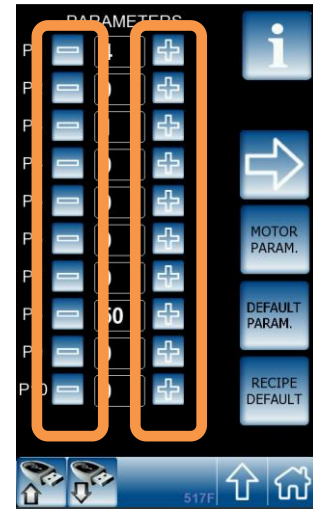



Depending on machine configuration, use the  and  buttons to modify the appropriate parameter values.

The new parameter value is automatically saved.

The Info button  shows the various parameters name.


Press the  button to change the parameters page.

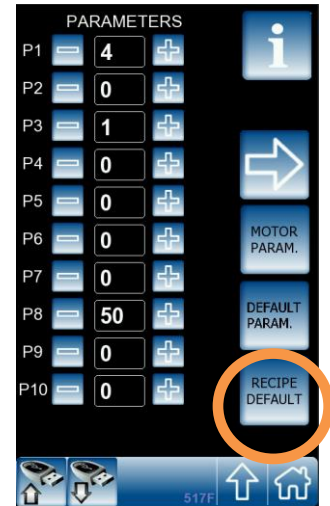


 Norm. Tecn. 60.2.66_08	TECHNICAL DOCUMENTATION ROTARY-ROTOTECH	Date: November 2021	Rev.12
	ENGLISH	Pag. 60 / 100	


Recipes Default

After the Parameters Default procedure, or to reinitialize all work program recipes, it's necessary to perform the Recipes Default procedure in the following way:

Press the "RECIPE DEFAULT"  button to start the procedure for setting all work program recipes with their default values



Confirm with the green button  to complete the **Recipe Default** procedure. In this way, the Recipes Default is performed.

Press the red button  to abort the **Recipe Default** procedure.



PLC CARD (U1)

New Installation or Software Update

This electronic card is supplied as spare part WITHOUT software.



- Switch off the machine.
- Mount mechanically the new card in place of the faulty card.
- Wire electrically the new card.

Follow the PLC card software loading procedure as described below:

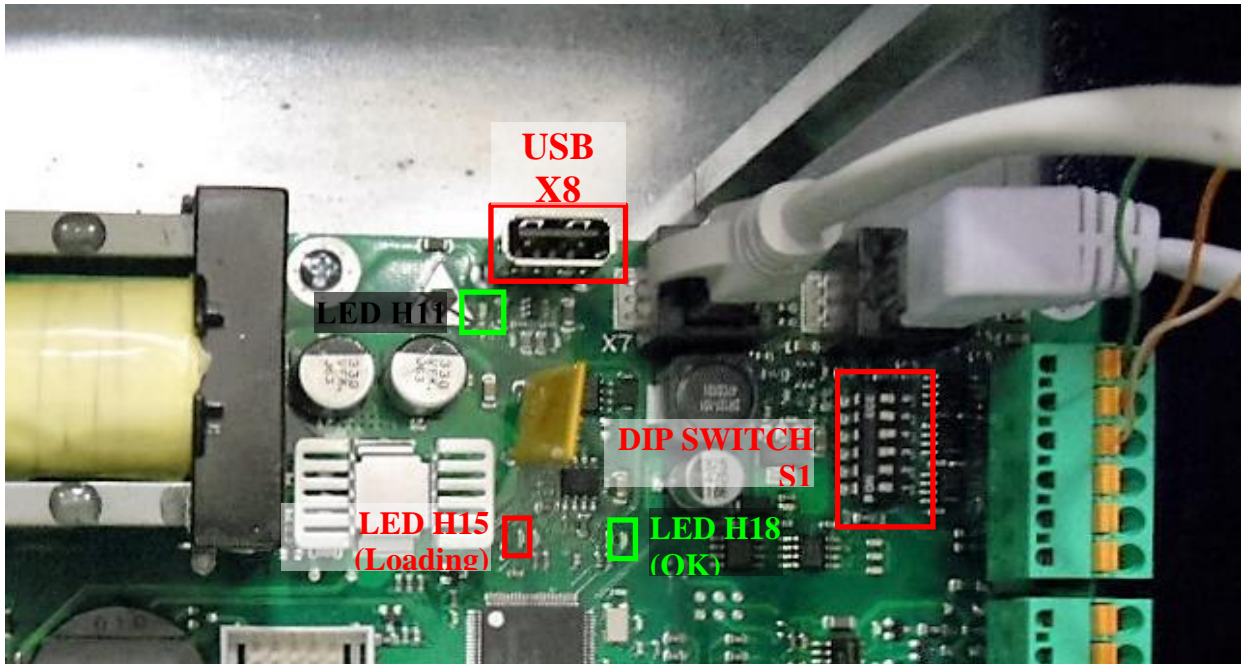
Retrieve the USB pen drive containing the original software versions which is supplied with the machine.



Robopac provides the original machine software with the USB 2.0 pen drive housed in the switchboard with all the technical machine documentation.

N.B.: In case it's necessary to create a new installation support (e.g: the original pen drive is lost) with a commercial pen drive:

- *use a USB 2.0 pen drive only*
- *copy the PLC board software files provided by Robopac at first directory level of pen drive*

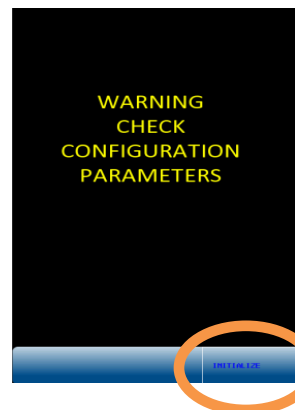


- Insert the USB pen drive into the port (X8 - USB), highlighted in red.
- Switch on the machine by turning the main switch.
- The green LED H11 begins to flash, indicating that the software download is in progress.
- The red LED H15 goes off as soon as the download of the software is successfully completed, and simultaneously the green LED H18 begins to flash.
- Switch off the machine.
- Remove the USB pen drive.
- Place the S1 switches of the card as follows:

Model Machine: FR	
Model Machine PDS – PVS	

If the panel is not initialized (update of previous software release) the warning page shown aside could appear. In this case, press the "INITIALIZE" button (at the lower right corner) to initialize the HMI, then turn off and on the machine. The warning window should no longer appear (HMI correctly initialized).

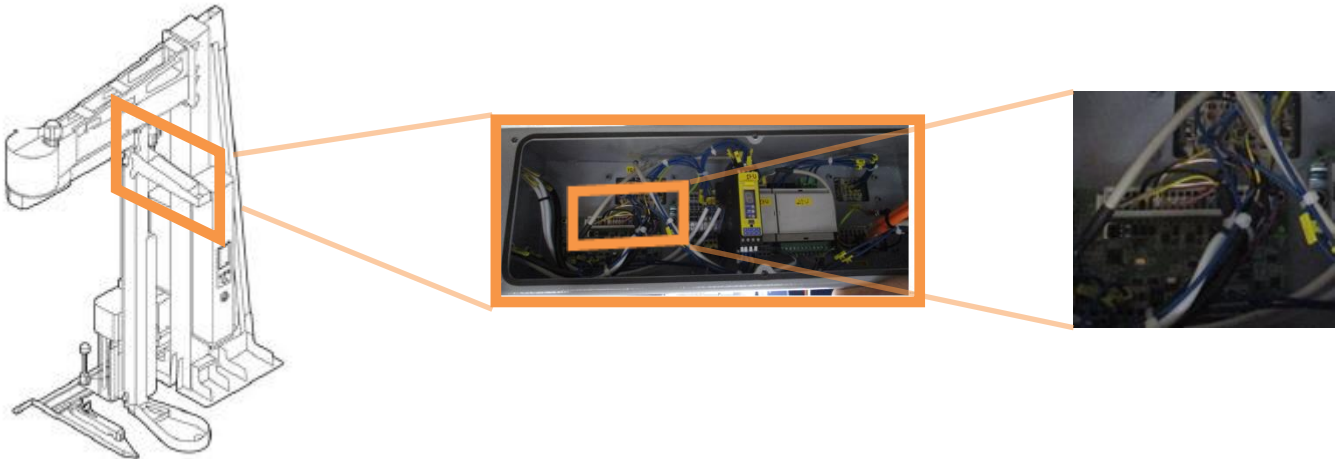
If the warning window doesn't appear, go ahead and press the RESET button.



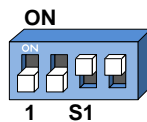
EXPANSION CARD (U11)

New Installation on the carriage of the PDS - PVS version machines.

This electronic card is provided as spare part COMPLETE with software.



- Switch off the machine.
- Mount mechanically the new card in place of the faulty card.
- Wire electrically the new card.
- Place the S1 switches of the card as follows:



- Switch on the machine.
- Remove the film from the last carriage reel (the one connected to the load cell)
- Calibrate the load cell by following the procedure below:

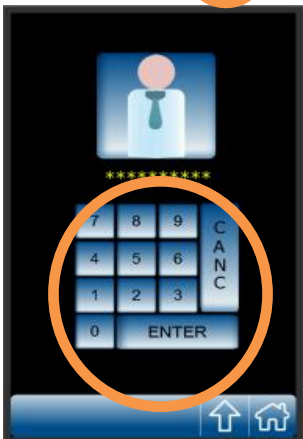
On startup screen, press the “Configuration” button:



On Configuration page press the user password selection button



With the onscreen keyboard enter the password **1111**, then press



If the password is correctly entered and accepted, the Configuration page returns, with the “maintenance technician” icon on the bottom status bar.



Press now the Service button:



LOAD CELLA CALIBRATION

On “Service” page press the “CELL” button



To access the Load Cell Calibration page.



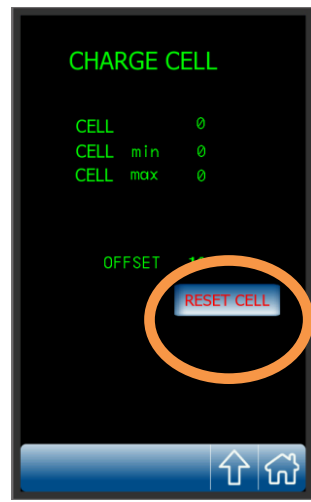
Press the Reset Cell button  to perform the calibration.

The new “CELL min” value must be about 10 units higher than the present value of “CELL”, while the “CELL max” value is equal to:

$$CELL\ min + (internal\ machine\ parameter\ P20) * 10$$

N.B.: CELL values are acceptable when in range:

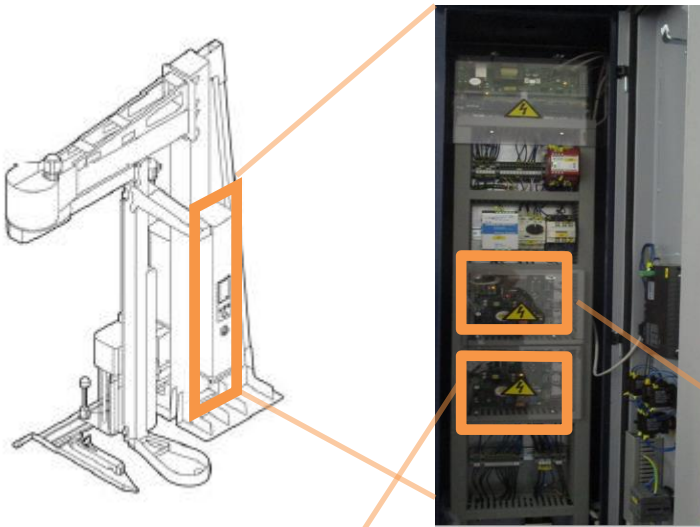
CELL min	CELL max
- 35	+ 15



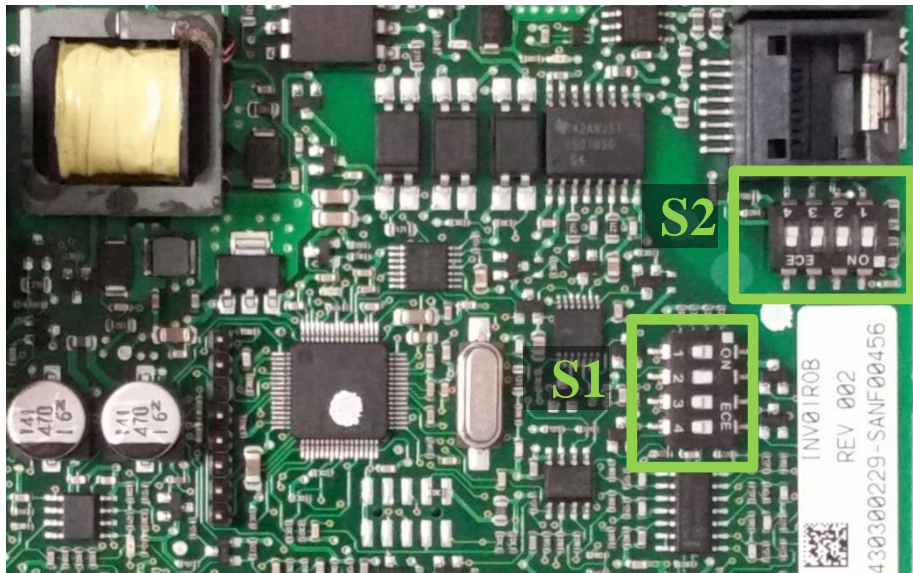
INVERTER CARD (T1 – T2)

New Installation

This electronic card is provided as spare part COMPLETE with software.



- Switch off the machine.
- Mount mechanically the new card in place of the faulty card.
- Wire electrically the new card.
- Place the S1 and S2 switches of the card as follows:



<p>Inverter Card U1</p> <ul style="list-style-type: none"> - Table Rotation Motor - Carriage Up/Down Motor 	<p>ON</p> <p>1 S1</p>	<p>ON</p> <p>1 S2</p> <p>if U2 PRESENT</p>	<p>ON</p> <p>1 S2</p> <p>if U2 NOT PRESENT</p>
<p>Inverter Card U2 (Pre-stretch Motors)</p> <ul style="list-style-type: none"> - PDS Pre-stretch Reel Motor - PVS Pre-stretch Reel Motor 	<p>ON</p> <p>1 S1</p>	<p>ON</p> <p>1 S2</p>	

- Switch on the machine
- Set the card configuration using the following procedure:

On startup screen press the Configuration button



On Configuration page press the user level password selection button.



Select the “maintenance technician” user level by pressing the user icon

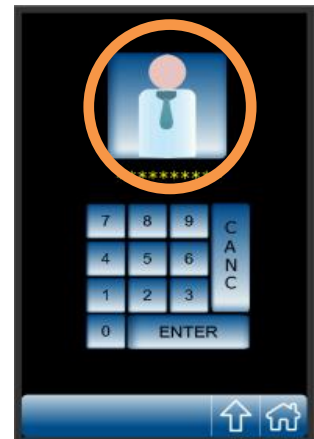


until the icon



appears.

Now, on the onscreen keyboard enter the password **6161**, then press



If the password is correctly entered and accepted, the Configuration page returns, with the “maintenance technician” icon on the bottom status bar.



Press now the Service button:



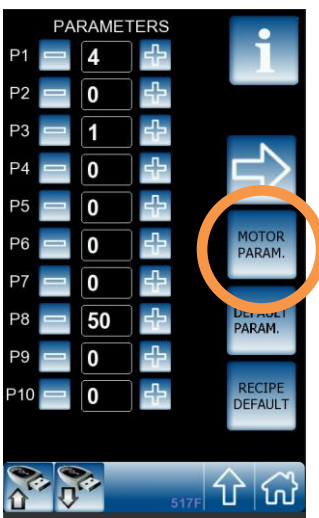
On "Service" page, press the "PARAM" button



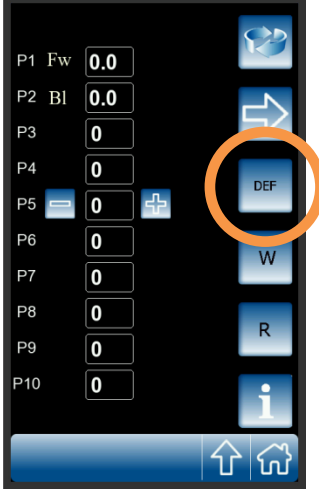
Press the



button to start the procedure for setting all machine parameters with their default values.

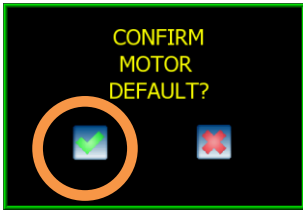


The "DEF" button starts the procedure for setting ALL motor parameters with their default values.



Confirm with the green button to complete the **Motors Parameters Default** procedure.

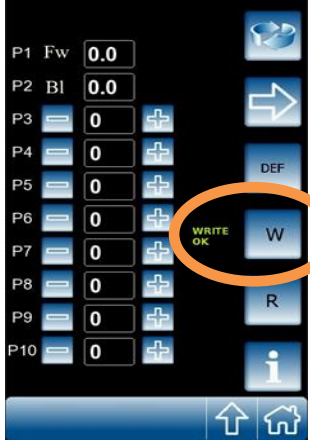
Press the red button to abort the **Motors Parameters Default** procedure.





To send the new inverter board the default parameters necessary press the button until the message “WRITE OK” appears on the screen, to confirm the new value has been correctly written.





In this way, the new card configuration is finished.

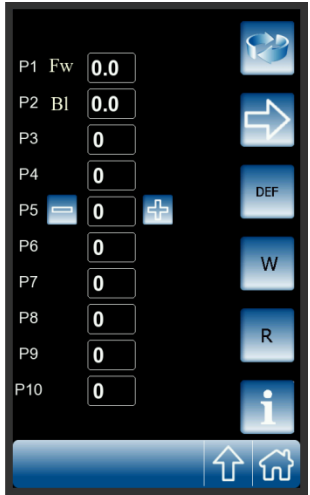



Motor parameters modification


Normally the modification of motors parameter is not necessary and it has to be specified by Service staff. At “maintenance technician” user level, the only modifiable parameter is the “Acceleration” parameter P5. To modify any other parameter, please contact Service staff.



The button at the top right shows the motor that is currently selected, in the following order:


-  Arm Rotation motor parameters
-  Roll Carriage Up/Down motor parameters
-  Stretch control motor parameters
-  Pre-stretch control motor parameters

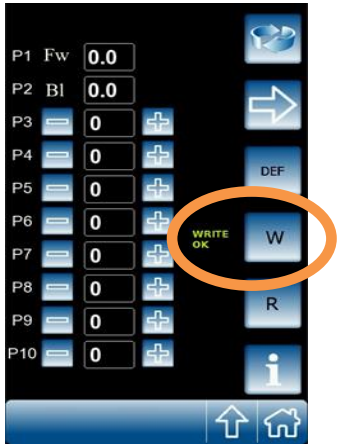


Press the  button to display the next page.
Each engine has 20 parameters (2 pages)

The Info button  displays the name of various parameters.

At "Robopac technician" user level, if it is necessary to change the value of a motor parameter, after the parameter modification by the  and  keys, it's necessary to

press the  button until the message “WRITE OK” appears on the screen, to confirm the new value has been correctly written.



ROBOPAC Norm. Tecn. 60.2.66_08	TECHNICAL DOCUMENTATION ROTARY-ROTOTECH	Date: November 2021	Rev.12
	ENGLISH	Pag. 72 / 100	

PRODUCT HEIGHT DETECTION PHOTOCELL CALIBRATION

Standard photocell (for clear products)

Adjust the photocell sensitivity trimmer to load centre



Dark product photocell

Suppression distance setting

1. Object detection

Position object to detect in front of the sensor at the distance required.
Turn distance adjustment trimmer (ADJ) to minimum: yellow LED OFF and green LED ON.



Rotate trimmer in a clockwise direction until the yellow LED and green LED turn ON. Object detection condition (A status of position indicator)



A

2. Background suppression

Remove object and ensure that the background is in front of the sensor: yellow LED OFF and green LED ON.



Rotate trimmer in a clockwise direction until the yellow LED and green LED turn ON: background detection condition (B status of position indicator).



B

The trimmer reaches maximum level with yellow LED OFF if the background is outside the operating range.

Rotate trimmer in an anticlockwise direction until yellow LED turns OFF and green LED ON: condition where background is outside operating range (C status of position indicator).



C

3. Setting and control

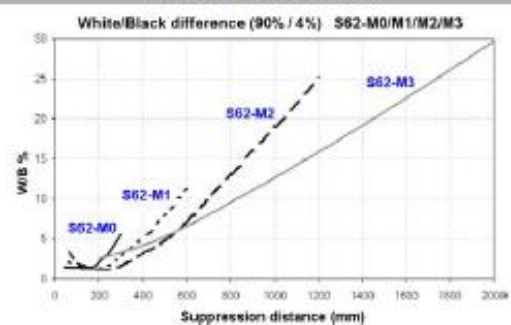
Rotate trimmer in an anticlockwise direction until the indicator reaches an intermediate point between position A and C.




If position A and C are close to each other, leave trimmer on position C. The sensor is now ready to function correctly and in stable conditions:


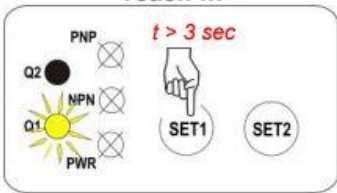


DETECTION DIAGRAM



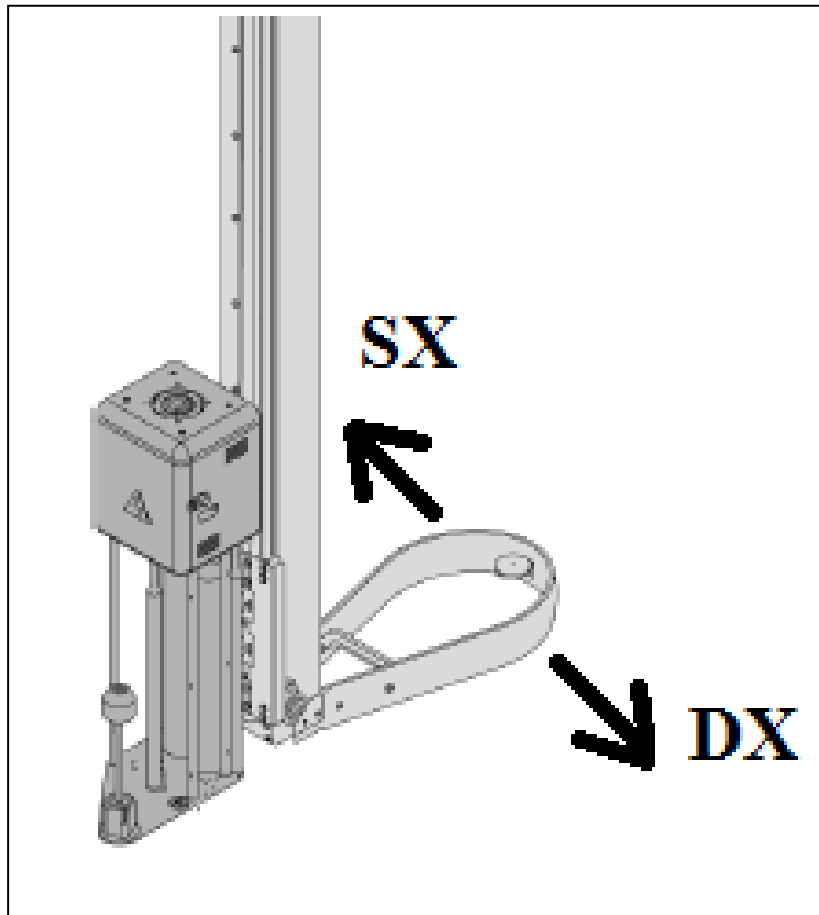
 Norm. Tecn. 60.2.66_08	TECHNICAL DOCUMENTATION ROTARY-ROTOTECH	Date: November 2021	Rev.12
	ENGLISH	Pag. 73 / 100	

Photocell for black products S65


	Place the target at the center of the pallet
<p style="text-align: center;">Teach-In</p> 	Keep pressed the Set1 button for more than 3 seconds, till led Q1 flashing
	Release the button, target detected

SETTING PROCEDURE FOR PHOTOCELLS ON EMERGENCY BUMPER on U12 Safety Control Unit

- Place the reflex
- Adjust the 2 photocells until the control unit switches on the GREEN led "Normal" = working condition
- If the control unit is in alarm, always displays the number 1 indicating the only pair of photocells present NOT aligned



Move the bumper to the right (DX) and left (SX) to be able to adjust the reflector so that it is as central as possible with the photocells

 Norm. Tecn. 60.2.66_08	TECHNICAL DOCUMENTATION ROTARY-ROTOTECH	Date: November 2021	Rev.12
	ENGLISH	Pag. 75 / 100	

Notions about PHOTOCELLS:

Emitter photocells (WB2):

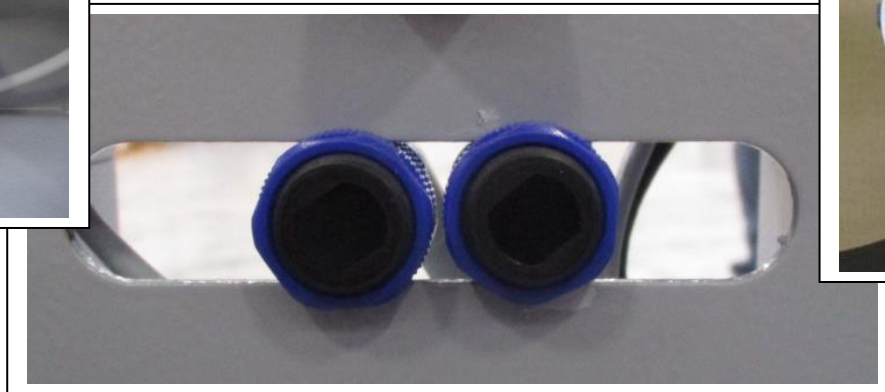
led power on (green), advise that the photocell is functioning.

Receiver photocell (WB3):

The red led (output led) advise the out-put status; when it is ON, it means that the photocell receives the signal from the emitter, so, the **alignment is fine**.

The green led got two meanings:

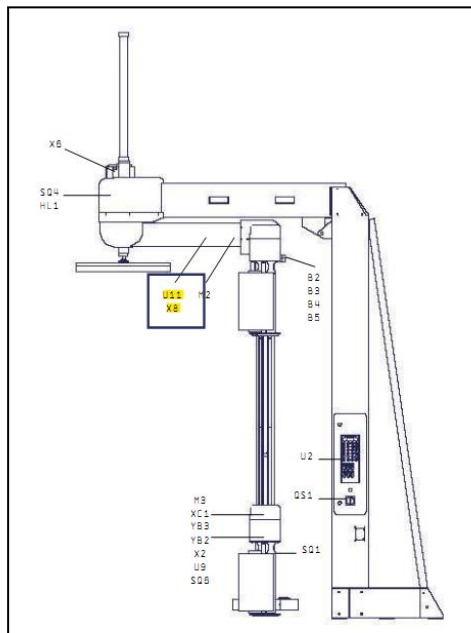
1. When the green led is ON and the red led is OFF, it advise that the photocell got the power supply, but it doesn't receive the signal from the emitter, so, the **alignment is NOT correct**.
2. When the green led is ON and the red led too, it advise that the received signal got a safety margin over the 30% compared to the communication value of the out-put.



Notes on the safety module:

Diagnostic and warnings

LED	Indication
● Power	Device is powered correctly
● NORMAL	No danger: safety outputs closed
● SAFE	Danger or fault: safety outputs open
	The 7-segment display shows detailed information on control unit current status



Normal operation signalling


INDICATION	STATUS	DESCRIPTION	TO DO
<ul style="list-style-type: none"> ● POWER ○ NORMAL ○ SAFE 	Alignment	The display shows the first device to be aligned and then the others in a sequence (1 to 4).	Align the safety devices (see 5.2)
<ul style="list-style-type: none"> ● POWER ○ NORMAL ○ SAFE 	Alignment	All connected devices are aligned	Close the Test contact (Pin 2) and restart the control unit to switch to normal operation (see 5.2)
<ul style="list-style-type: none"> ● POWER ○ NORMAL ● SAFE 	SAFE	The indicated safety device beam is interrupted. If many devices are in this status, the first one is indicated, then the others in a sequence (1 to 4).	Clear the area or check device connections
<ul style="list-style-type: none"> ● POWER ● NORMAL ○ SAFE 	NORMAL OPERATION	The device is in normal operating conditions and monitored area is safe.	
<ul style="list-style-type: none"> ● POWER ● NORMAL ● SAFE 	Interlock	Waiting for the START command in manual reset mode	Push reset control
<ul style="list-style-type: none"> ● POWER ●/○ NORMAL ○/● SAFE 	NORMAL OPERATION/ SAFE	The decimal point indicates that the EDM function is active (see 4.7)	
<ul style="list-style-type: none"> ● POWER ○ NORMAL ● SAFE 	SAFE	TEST push-button pressed (contact 2 open)	Check TEST push-button connections (see 4.6)



Failure status

INDICATION	STATUS	DESCRIPTION	TO DO
<p>○ POWER ○ NORMAL ○ SAFE</p> <p>8.</p>	Off	Power disconnected or inner fuse blown due to overload.	Check power supply
<p>● POWER ○ NORMAL ● SAFE</p> <p>A. ↻ B.</p>	FAILURE LOCKOUT	It is impossible to determine selected reset mode	Check MAN/AUTO switch connection (terminal 6, see 4.3)
<p>● POWER ○ NORMAL ● SAFE</p> <p>A. ↻ 0.</p>	FAILURE LOCKOUT	OSSD test routine has failed.	Check OSSD outputs connections (see 4.3). Make sure there is no short-circuit and check the features of the load downstream of the OSSD (see section 9)
<p>● POWER ○ NORMAL ● SAFE</p> <p>A. ↻ E.</p>	FAILURE LOCKOUT	EDM test has failed	Check EDM connections (see 4.5) or disable EDM function (see 4.3) if you do not wish to use it.
<p>● POWER ○ NORMAL ● SAFE</p> <p>A. ↻ A.</p>	FAILURE LOCKOUT	Start signal time-out tripped.	Make sure you hold the Start button depressed for less than 5s.
<p>● POWER ○ NORMAL ● SAFE</p> <p>A. ↻ 0.</p>	FAILURE LOCKOUT	One of microprocessor tests has failed	Disconnect power supply and reconnect it. If error persists, please contact the Technical Service.
<p>● POWER ○ NORMAL ● SAFE</p> <p>A. ↻ A ÷ 4.</p>	FAILURE LOCKOUT	Test of indicated safety sensor has failed.	Make sure there is no interference across different photocell sets.



 Norm. Tecn. 60.2.66_08	TECHNICAL DOCUMENTATION ROTARY-ROTOTECH	Date: November 2021	Rev.12
	ENGLISH	Pag. 79 / 100	

REMOTE CONTROL INSTALLATION & SETTING --- until September 2016 ---

To install the remote control it is necessary to perform the procedure of RX & TX codes in self-learning of the receiver.

New code setting

- 1.1. Set the dip switch 1 & 2 to OFF.
- 1.2. For the channel 1, press the button P1 till the related led will become ON (LED1).
- 1.3. Press the (START) push button of the remote and keep it pressed until the second led will become ON too (the second led makes a blink).
- 1.4. Release the (START) push button of the remote
- 1.5. The receiver will confirm the successful setting by a double blinks (2) of the two leds
- 1.6. In case of failed setting, the receiver will turn OFF the related led of the channel and will not make any double blink of setting confirmation. If the memory of the codes is full, the receiver will advise this event by seven (7) blinks of the two leds.
- 1.7. For the channel 2, press the push button P2; the other operations works the same as above (setting the STOP push button of the remote).

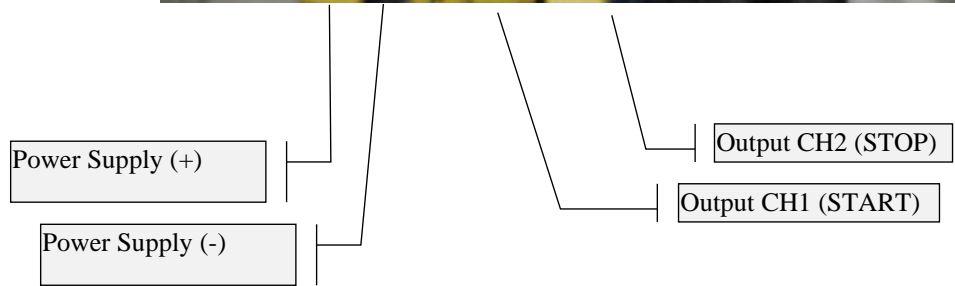
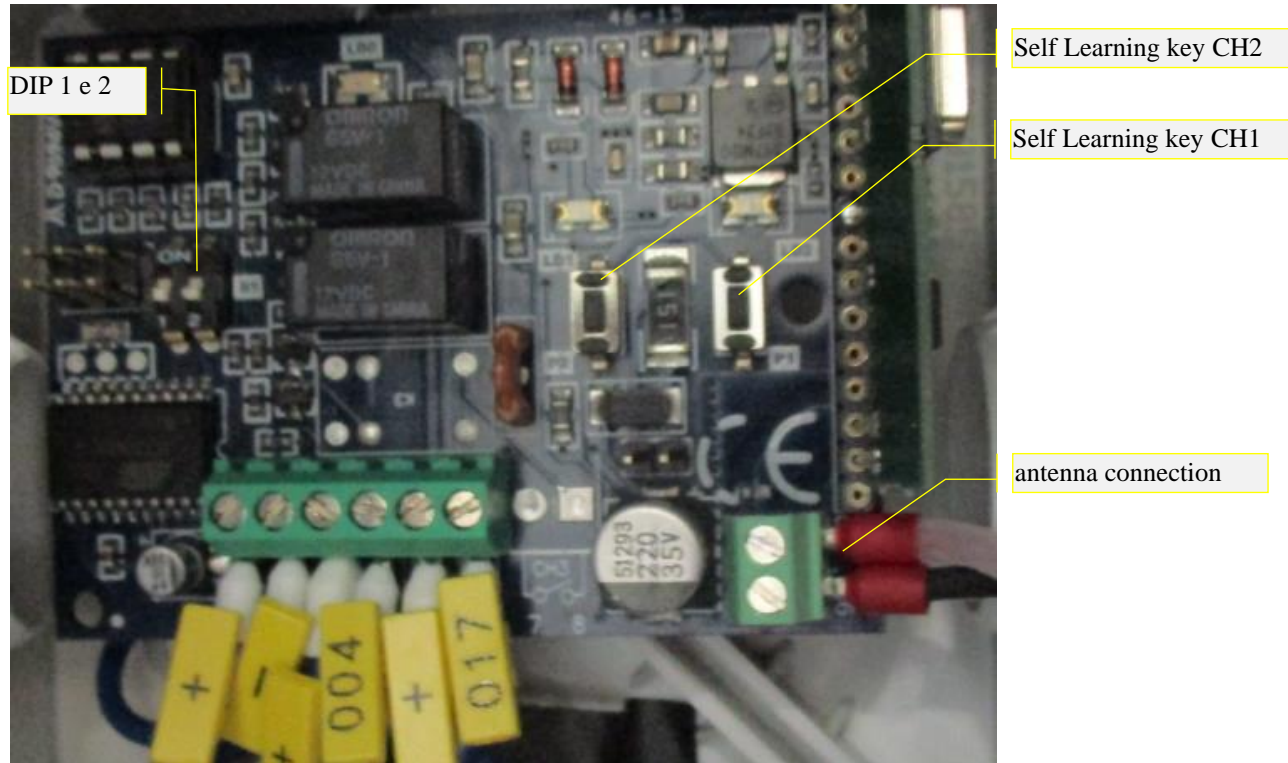
Set code deleting

- 2.1. Press the push button P1 (or P2) until the related led will become ON LED1 (or LED2).
- 2.2. Press the push button Ch.1 (or Ch.2) of the remote.
- 2.3. The receiver will confirm the successful deleting by five (5) blinks of the two leds
- 2.4. In case of failure on the receiver the related led of the selected channel and will not make the five blinks of confirmation.

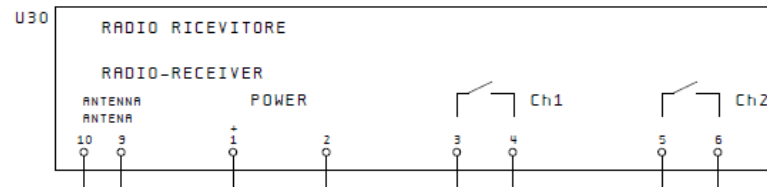
All set code deleting

- 3.1. Press the push button P1 until the LED1 will become ON and keep it pressed until it will become OFF again..
- 3.2. On the receiver will become ON the LED1, and after 7 seconds will become OFF again giving confirmation of the deleted codes.

RECEIVER RADIO CARD (code 1430300157)



RECEIVER RADIO CARD DESCRIPTION

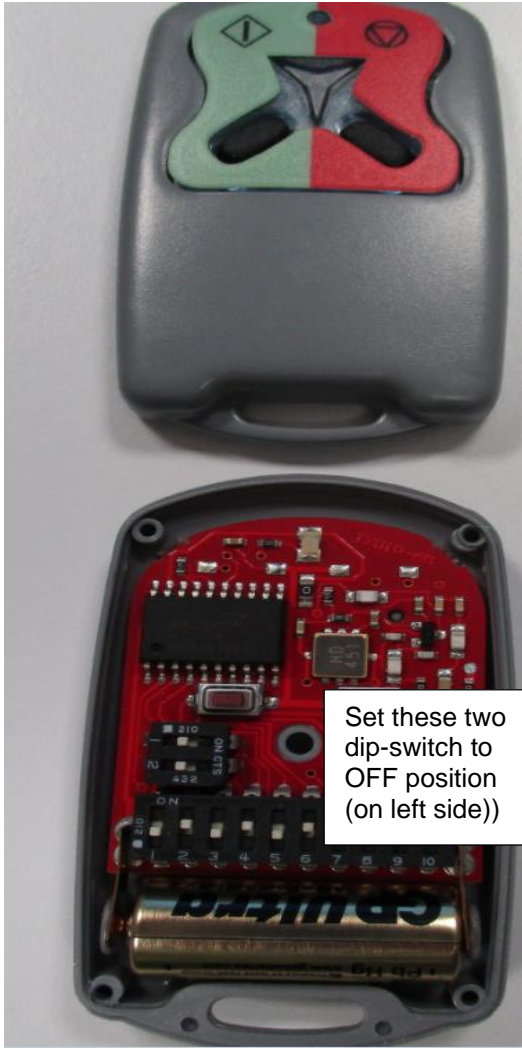


ELECTRICAL CONNECTION

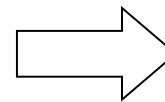
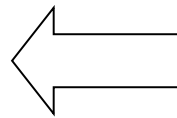
9,10	Central "Antenna" – Sock "Antenna"
3,4	N.O. contact channel 1 (START)
5,6	N.O. contact channel 2 (STOP)
1	0 V ac,dc
2	+12V,+24V ac,dc

TECHNICAL CHARACTERISTICS

Power supply	+12V,+24V ac,dc
Consumption	50 mA
Receiver Frequency	433.92 MHz e 30.875 MHz
Min / Max. temperature of workng	-25°C +70°C
Dimensions	+12V,+24V ac,dc

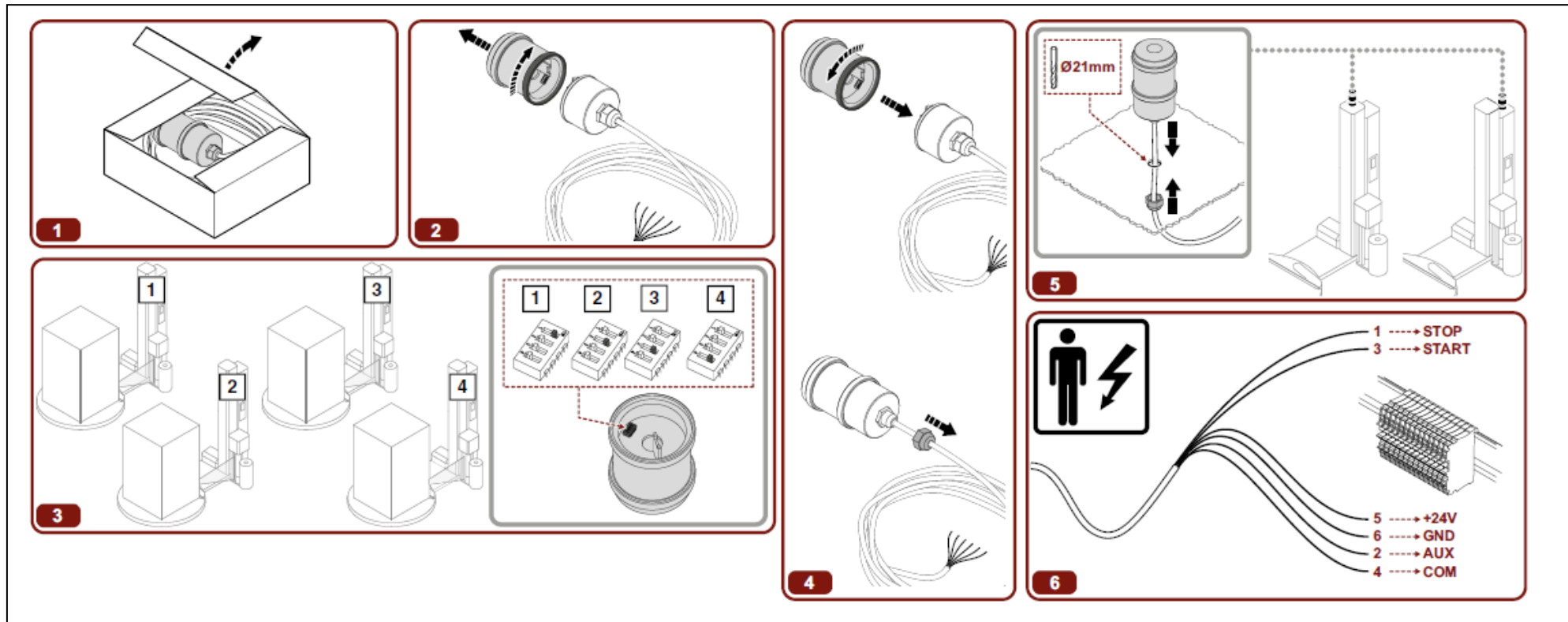
REMOTE CONTROL EMITTER CARD CONFIGURATION (code 0590300000)

Set these two dip-switch to OFF position (on left side)



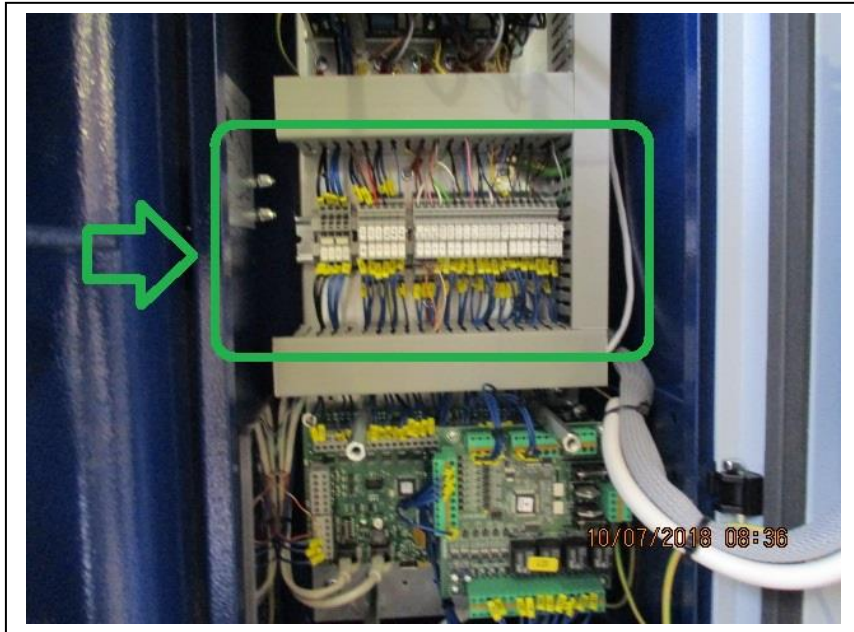
Set these two dip-switch to ON position (on right side)

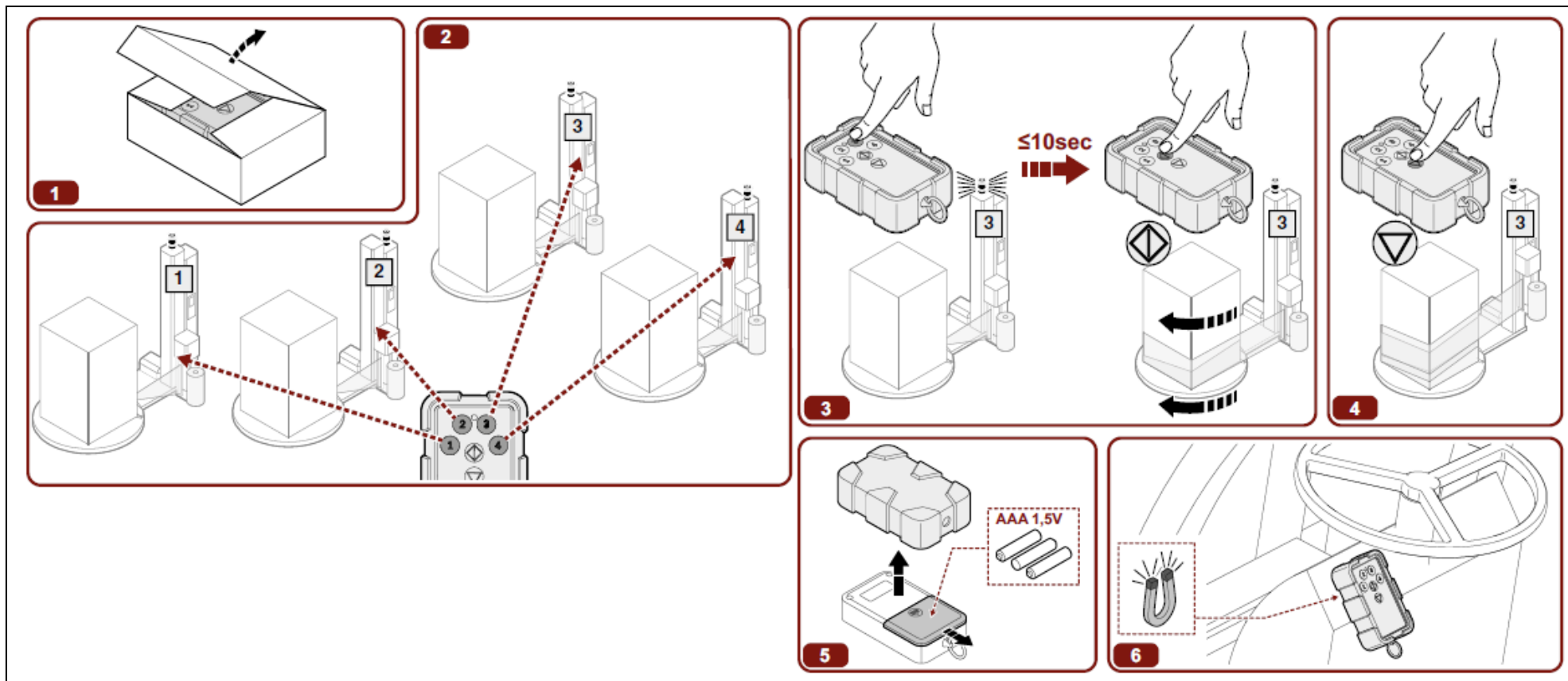
1.


NEW RADIO CONTROL INSTALLATION --- from September 2016 ---**RECEIVER Installation**

ROBOPAC Norm. Tecn. 60.2.66_08	TECHNICAL DOCUMENTATION ROTARY-ROTOTECH	Date: November 2021	Rev.12
	ENGLISH	Pag. 84 / 100	


Check the wiring diagram for the correct connection to machine connector





TRANSMITTER Installation

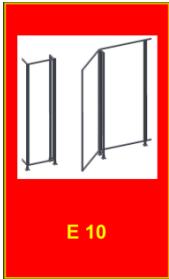
 Norm. Tecn. 60.2.66_08	TECHNICAL DOCUMENTATION ROTARY-ROTOTECH	Date: November 2021	Rev.12
	ENGLISH	Pag. 86 / 100	

R-CONNECT DEVICE ACTIVATION

<p>Rconnect device registration</p> <p>check that the FW Release and GSM field fields have values other than 0. Press the 'REGISTER' button and wait for all 4 LEDs to be green</p>	
---	---

ALARM LIST AND TROUBLESHOOTING

Alarm code	Alarm description	Troubleshooting	Cause of the fault	Solution
	Emergency push button pressed			Turn and lift the mushroom head button and press RESET
		Check the SB1 emergency press button contact	Contact broken	Replace the SB1 emergency limit stop contact
	Active Bumper Safety	Remove any obstacle that blocks the barriers photocells	The bumper security has encountered an obstacle.	
		Check the alignment of the sensors (bumper and their related reflectors)	Wrong photocells alignment with related reflectors	Make the photocells alignment as indicated in above paragraph
		Check the appropriate working of the safety device photocells Emitter and receiver for bumper safety (see paragraph on).	Default photocells Emitter and receiver for bumper safety	Replacement and setting of the safety device (as indicated in paragraph on).
		Check the appropriate working of the safety device which manage the emergencies (see paragraph on).	Defect of the emergency manager device	Replacement and setting of the safety manager device (as indicated in paragraph on).
		Check the appropriate working of the correspondent input of the PLC Card	Possible damage of the PLC's input	Replace PLC Card.



Opened security doors.

Check micro-switch closing doors.


Wrong connection micro-switch
closing doors




Active protection barriers.




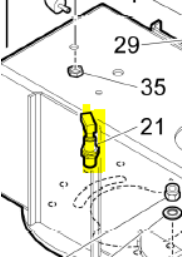
Remove any obstacle that blocks the
barriers photocellsWrong photocells alignment with
related reflectors



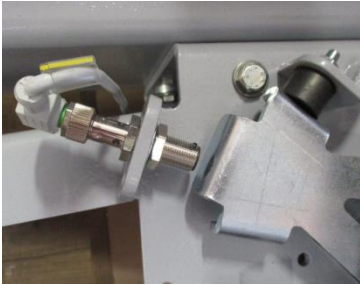
<div style="background-color: red; color: yellow; padding: 5px;"> <p>FAULT ALARM (E30) MOTOR</p> <ul style="list-style-type: none"> POWER DRIVER LOW POWER DRIVER HIGH OVER VOLTAGE MAX VOLTAGE UNDER VOLTAGE HW OVER CURRENT OVER HEAT PHASE FAIL CURRENT MAX CURRENT INT MAX PARAMETER WRONG COM. ERROR ENABLE DRV A ENABLE DRV B <p>FFFF</p> </div> <p>Motor Index: 1 = Table rotation 2 = Carriage 3 = Stretch 4 = Pre-Stretch</p>	<p><u>Fault motore</u></p> <p>POWER DRIVER LOW/HIGH Incorrect voltage Motor Enable</p> <p>ENABLE DRV A/B Absence Motor Enable</p> <p>OVER / MAX / UNDER VOLTAGE Incorrect voltage Motor supply</p> <p>OVER HEAT High temperature</p> <p>PHASE FAIL Motor incorrectly connected</p> <p>CURRENT (INT) MAX Overcurrent (short / full) of the motor (as a function of motor parameters)</p> <p>HW OVER CURRENT Instantaneous overcurrent (non programmable)</p> <p>COMM.ERROR Communication error (see 83)</p>	<p>Disconnect the motor indicated in the error message from the inverter card and start a cycle.</p>	<p>If the error message no longer appears, it could be a motor fault</p> <p>If the message persists, it could be an inverter card fault</p>	<p>Replace the motor.</p> <p>Replace the inverter card.</p>
	<p>Possible gear motor fault.</p>	<p>Possible gear motor fault.</p>	<p>Replace the gear motor</p>	

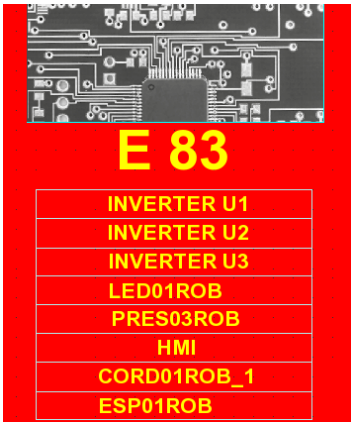
	<p>Film break alarm for carriages with driven pre-stretch only</p>	<p>Check correct load cell operations (extensometer)</p>	<p>The load cell does not send the signal to the signal amplifier board.</p> <p>The load cell correctly operates</p>	<p>Replace the film reel on the carriage or re-attach the edge of the film to the product and press START.</p> <p>Replace the load cell (extensometer).</p> <p>Replace the cell signal amplifier/pre-stretch motor inverter board.</p>
	<p>Arm rotation alarm</p> <p>Lack of phase sensor reading for a time greater than 2 wraps of the rotation arm.</p>	<p>Check revolution counter sensor position (the alarm appears with there is no PLC input signal for at least 2 table revolutions)</p> <p>Check correct sensor operations</p> <p>Check IN07 input on the PLC board</p> <p>Check motor arm rotation</p> <p>Check brake motor arm rotation</p> <p>Check the gearbox connected to the rotation arm motor</p>	<p>Incorrect sensor position.</p> <p>Possible sensor and relevant wiring fault</p> <p>Possible PLC board fault</p> <p>Possible motor arm rotation fault</p> <p>Possible Inverter Card T1 fault</p> <p>Possible brake motor arm rotation fault</p> <p>Possible PLC board or brake enable command K5 fault</p> <p>Possible fault of the gearbox</p>	<p>Correctly reposition the sensor</p> <p>Correctly reposition the sensor</p> <p>Replace the PLC board.</p> <p>Replace the Arm rotation gearmotor</p> <p>Replace the inverter card T1</p> <p>Replace the Brake Arm rotation motor</p> <p>Replace the PLC board or the Brake Enable K5</p> <p>Replace the Arm rotation gearmotor</p>

	<p>Thermal Alarm E62 from OCTOBER 2019</p> <p>The thermal protection brake has detected overheating.</p>	<p>Possible overheating caused by the brake that is not disconnected from the engine</p>	<p>Possible overheating caused by the brake that is not disconnected from the engine</p>	<p>Check the arm rotating motor and the brake connected to it.</p> <p>Check the function of the brake and replace it necessary</p> <p>Check the electrical circuit that supplies the brake and when to replace the faulty part electric.</p>
	<p>Carriage speed alarm or Blocked Carriage</p> 	<p>The carriage is not lifted at the set speed. Check correct carriage encoder positioning.</p>	<p>Incorrect sensor position.</p>	<p>Correctly reposition the sensor</p>
		<p>Check correct carriage encoder operations and wiring</p>	<p>Possible encoder sensor fault or wiring fault.</p>	<p>Replace the sensor or restore wiring</p>
		<p>Check the carriage speed encoder sensor input on the U11 card The H3 led blinks quickly.</p>	<p>Possible U11 card fault</p>	<p>Replace the U11 card</p>
	<p>Anomaly of the Roping Device circuit.</p>	<p>Check electrical connections and card of the Roping Device.</p>	<p>The Roping Device control card may be fault.</p>	

 <p>E 66</p>	<p>Anomaly of the current flow in the Welder circuit</p>	<p>Check electrical connections of the welder circuit.</p>	<p>The welder relays may be blocked.</p>	<p>Check the arm rotating motor and the brake connected to it.</p>
 <p>E 66</p>	<p>Thermal Alarm E62 till OCTOBER 2019</p> <p>The thermal protection brake has detected overheating.</p>	<p>Possible overheating caused by the brake that is not disconnected from the engine</p>	<p>Possible overheating caused by the brake that is not disconnected from the engine</p>	<p>Check the function of the brake and replace it necessary</p>
 <p>E 67</p>	<p>Low air pressure in the pneumatic circuit</p>	<p>Check air connection in the pneumatic system.</p>	<p>Lack of air in pneumatic system</p>	<p>Check the electrical circuit that supplies the brake and when to replace the faulty part electric.</p>

	<p>Attempting to start the cycle with the -Welding cutting arm on the correct setting of back.</p> <p>Exceeded time-out for -Welding cutting arm not in the correct position of forward.</p> 	<p>Check the air pressure in the pneumatic system</p>	<p>Lack air in the pneumatic system or failure of the link.</p>	
	<p>Attempting to start the Welding cutting cycle without the arm rotation on phase position.</p> 	<p>Check the back position sensor on the cutting-welding arm..</p> <p>Check the phase sensor of arm rotation position.</p>	<p>Possible failure of the sensor arm into back position or failure associated wiring.</p> <p>Possible failure of the phase sensor arm rotation or failure associated wiring.</p>	<p>Sensor replacement or restore wiring.</p> <p>Phase Sensor arm rotation replacement or restore wiring.</p>

 <p>E 69</p>	<p>Top platen (Pressure) blocked alarm</p>  	<p>The pressure platen did not reach the product (or limit stop) within the set time. Check motor drive</p>	<p>Possible motor fault.</p>	<p>Replace the motor</p>
	<p>Check pressure sensors on plate and limit stop</p>	<p>Possible sensor or limit stop and relevant wiring fault.</p>	<p>Replace the sensor or limit stop or restore wiring</p>	
	<p>Check (U14) card operation</p>	<p>Possible (U14) card fault</p>	<p>Replace (U14) card</p>	



INVERTER1
(Table Rotation + Carriage)

INVERTER2
(Stretch + pre-Stretch)

INVERTER3
(Pressor)

LED01ROB ***
(Control Card for leds)

PRES03ROB
(Control Card for load cell)

HMI
(Touch screen Panel)

CORD01ROB_1 ***
(Control Card for roping)

ESP01ROB ***
(Expansion inputs / output card)

The screen shows the electronic cards that show the communication alarm simultaneously.

*** from July 2018

*** from July 2018

*** from July 2018

Check connections with the various devices

Note. To exit the alarm screen, press the button hidden in the upper right vertex

Possible communication wire fault

Replace connection wire

Try connecting one device at a time.

Note. To exit the alarm screen, press the button hidden in the upper right vertex

Possible electronic card fault

Replace the electronic card.

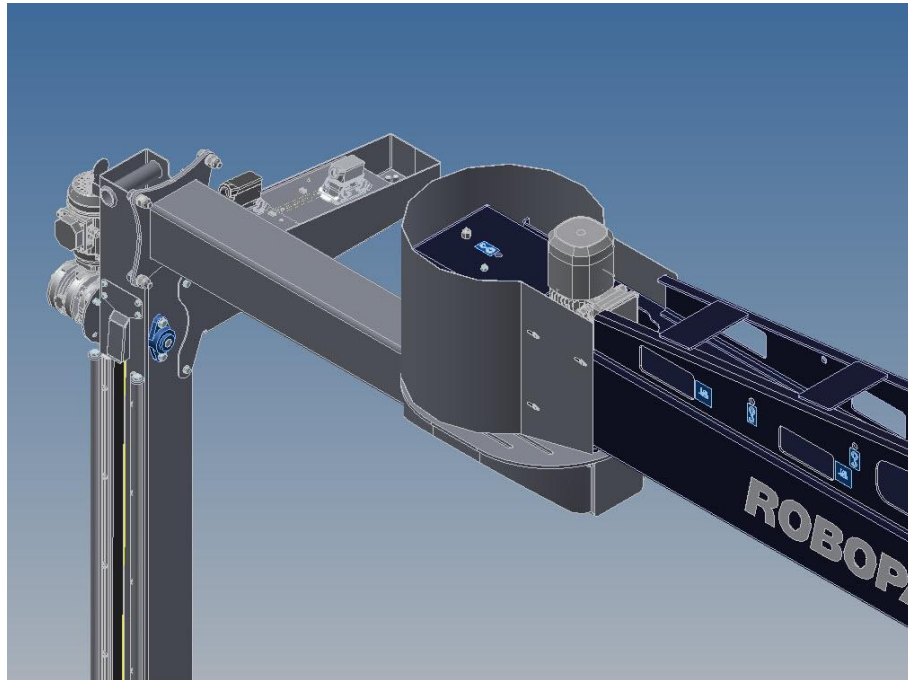
	<p>Wrong configuration of parameters</p> <p>The list of parameters is not 'consistent with the value of Csum stored.</p>	<p>When the machine turn on it was found a discrepancy between the configuration parameters stored in the memory and the set.</p>	<p>Possible is a "damaging the machine configuration parameters</p>	<p>Restore the correct parameters by copying from the USB stick with the machine</p> <p>Or, to manually set the parameters, press the button</p>
<p>E90</p>	<p>Emergency Feedback alarm</p>	<p>During machine start up, checking the status of contactor has failed.</p>	<p>Check the contactor release and / or its connections.</p>	<p>Replace the contactor, or restore correct wiring.</p>

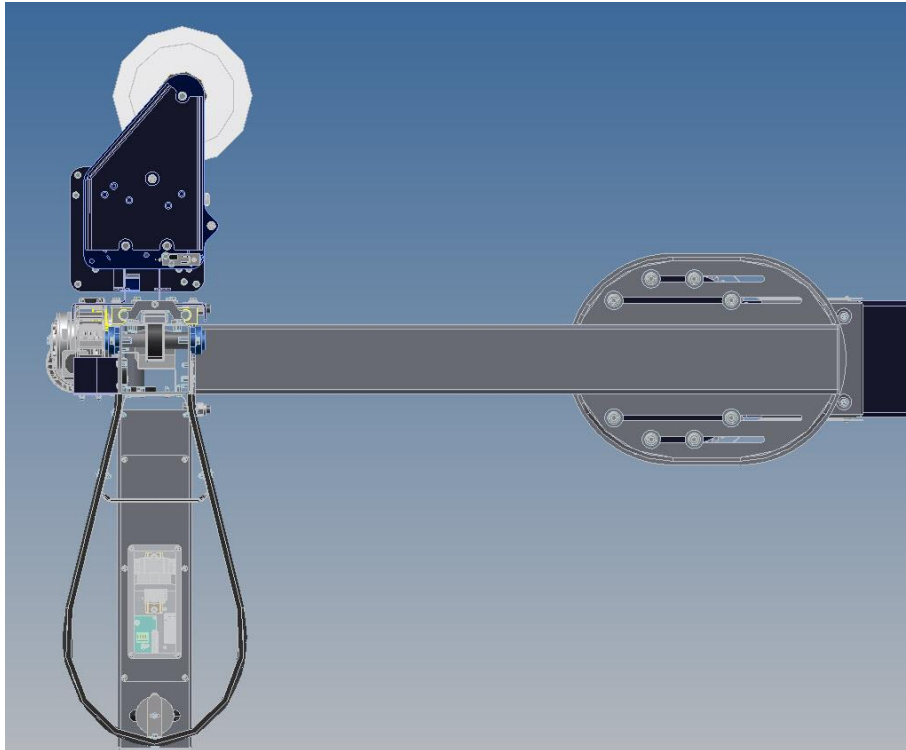
ROBOPAC Norm. Tecn. 60.2.66_08	TECHNICAL DOCUMENTATION ROTARY-ROTOTECH	Date: November 2021	Rev.12
	ENGLISH	Pag. 97 / 100	

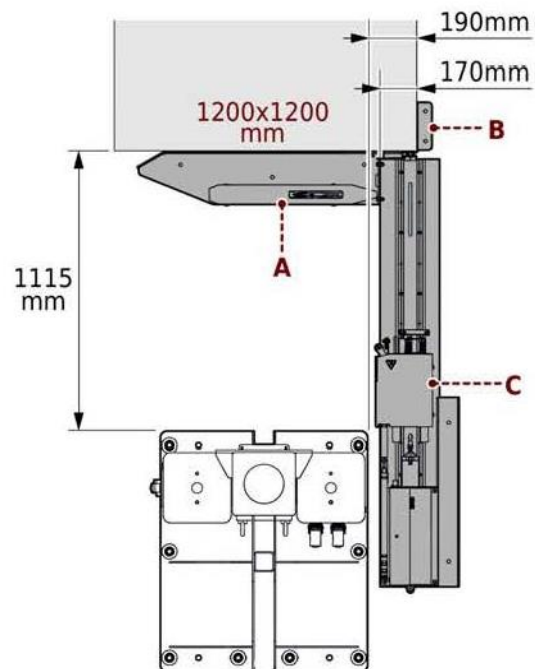
MECHANICAL AND PNEUMATIC ADJUSTMENTS

Rotating arm length adjustment

The Rotary / Rototech is designed to work with the maximum variable size products between 1200x1200 mm and 1400x1400 mm. Unless otherwise indicated, the machine (including the stapling and cutting device) must be tested and shipped with adjustment for a product of 1200x1200 mm maximum size as following pictures.







ROBOPAC Norm. Tecn. 60.2.66_08	TECHNICAL DOCUMENTATION ROTARY-ROTOTECH	Date: November 2021	Rev.12
	ENGLISH	Pag. 100 / 100	

APPENDIX 1 : Security module SG BWS T4 for emergency BUMPER

Below is an extract from the technical manual of the SG BWS T4 safety module for emergency BUMPER



for a more in-depth analysis of the component, please read the technical manual of the component (ask Robopac service)



> SG-BWS-T4
Safety Control Unit

4.3. Minimum connections (1 photocell, no EDM, automatic restart)

The control unit terminals layout and the minimum connection to check system operation are shown below. The photocells power (blue and brown wires) must be connected to the same power supply of SG-BWS-T4.

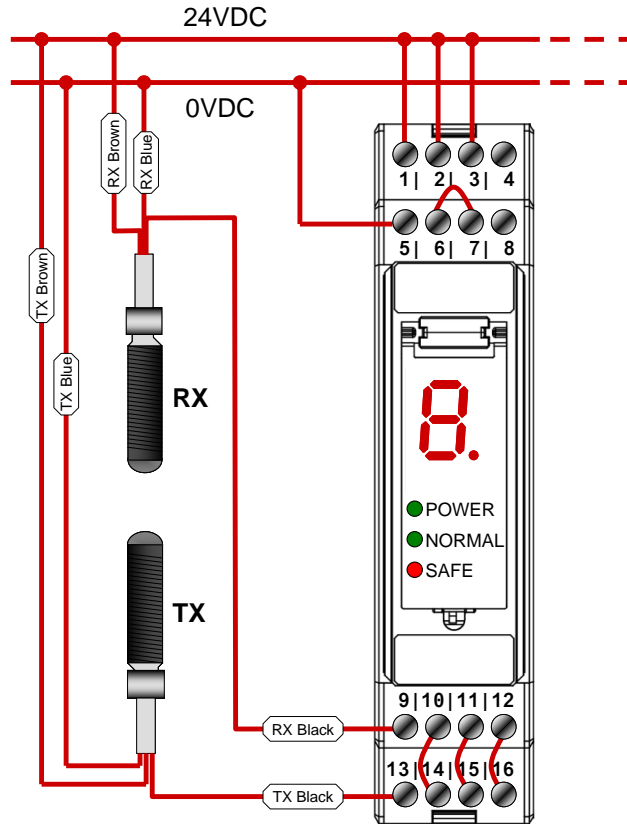


Fig. 13 Minimum connection for function test

SIGNAL	CONTACT	CONNECTION
VDC	1	24 Vdc ext.
START/TEST/RESET	2	24 Vdc ext.
EDM ENABLE	3	24 Vdc ext.
OV	5	0 Vdc ext.
MAN/AUTO	6	OSSD1 (7)
RX1	9	PNP output of receiver photocell 1 (black)
RX2	10	TX2 (14)
RX3	11	TX3 (15)
RX4	12	TX4 (16)
TX1	13	TEST of emitter photocell 1 (black)

Tab. 5 Minimum connection details for function test

4.5. Connecting the safety photocells:

0 to 4 safety photocells can be connected to the SG-BWST-4.
Connections required for installing 4 photocells:

SIGNAL	CONTACT	CONNECTION
RX1	9	PNP output of receiver photocell 1 (black)
RX2	10	PNP output of receiver photocell 2 (black)
RX3	11	PNP output of receiver photocell 3 (black)
RX4	12	PNP output of receiver photocell 4 (black)
TX1	13	TEST of emitter photocell 1 (black)
TX2	14	TEST of emitter photocell 2 (black)
TX3	15	TEST of emitter photocell 3 (black)
TX4	16	TEST of emitter photocell 4 (black)

Tab. 7 Safety photocells connections

If not all 4 photocells are installed, it is necessary to make a jumper to connect the set of TXn-RXn contacts not in use.

The diagram below shows an example where two sets of photocells are connected. **The control unit does not power** the photocells, it is hence necessary to **connect all power cables** (brown and blue cables) **to the same power supply as SG-BWS-T4.**

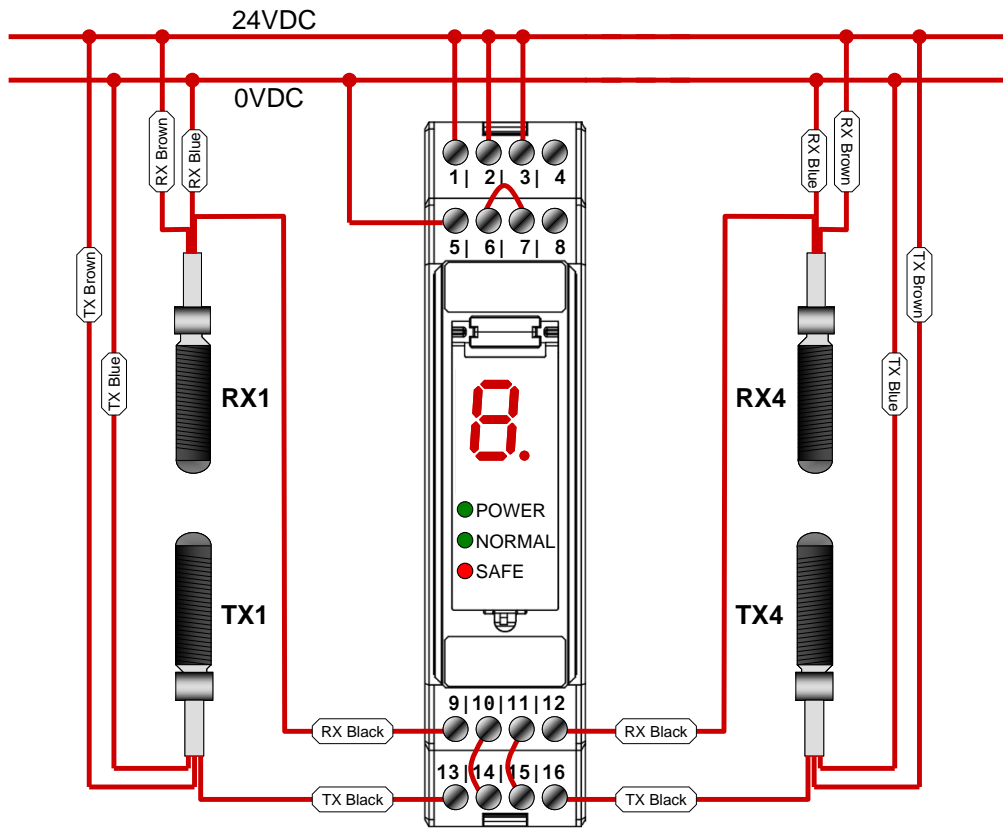


Fig. 15 Safety photocells connection

Photocell connectors are hard-wired as follows:



4.6. Connecting the safety photocells for SG-BWS-T4-2 model:

0 to 8 safety photocells can be connected to the SG-BWS-T4 in series of 2.
Connections required for installing 8 photocells:

SIGNAL	CONTACT	CONNECTION
RX2	9	PNP output of receiver photocell 2 (black)
RX4	10	PNP output of receiver photocell 4 (black)
RX6	11	PNP output of receiver photocell 6 (black)
RX8	12	PNP output of receiver photocell 8 (black)
TX1	13	TEST of emitter photocell 1 (black)
TX3	14	TEST of emitter photocell 3 (black)
TX5	15	TEST of emitter photocell 5 (black)
TX7	16	TEST of emitter photocell 7 (black)

Tab. 8 Safety photocells connections

If not all 8 photocells are installed, it is necessary to make a jumper to connect the set of TXn-RXn contacts not in use.

To each TXn-RXn can also be connected a single TX/RX couple as in SG-BWS-T4 model.

The diagram below shows an example where 4 sets of photocells are connected in series of 2.

The control unit does not power the photocells, it is hence necessary to connect all power cables (brown and blue cables) to the same power supply as SG-BWS-T4.

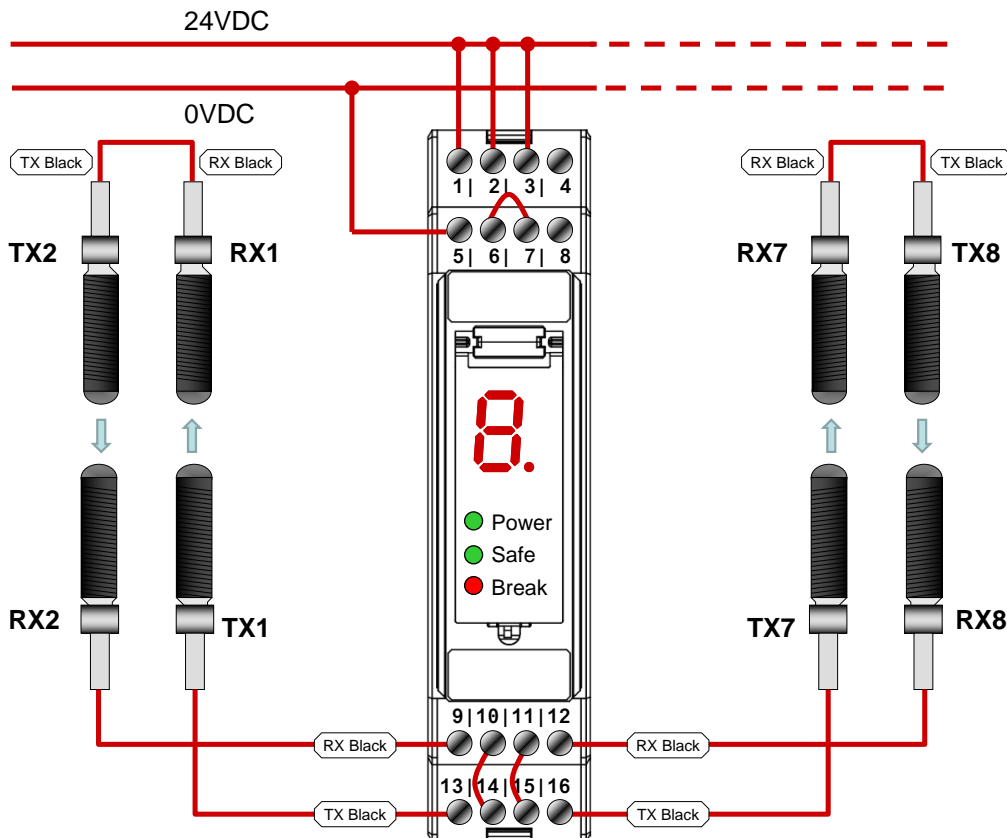


Fig. 16 Safety photocells series connection for SG-BWS-T4-2 model only



Carefully check there is no mutual interference between photocells connected in series on the same channel. This can be achieved mounting Transmitters and Receivers on opposite side as in Fig. 16

4.7. Connecting the external relays and EDM

To use the EDM function available in the BW-ST4, simply connect devices as shown below.

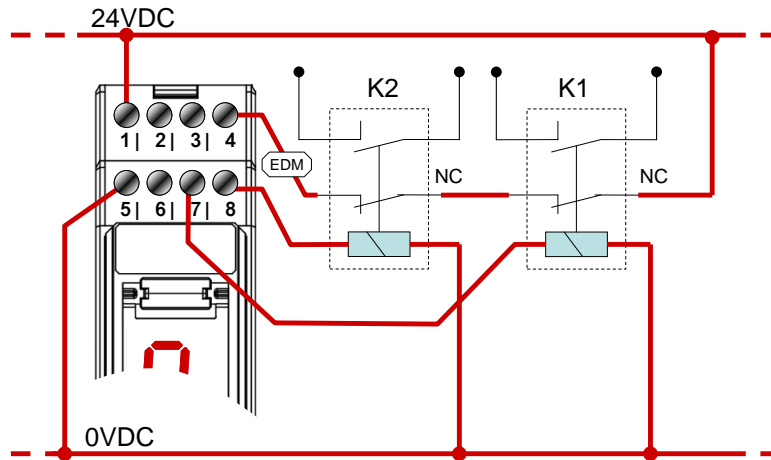


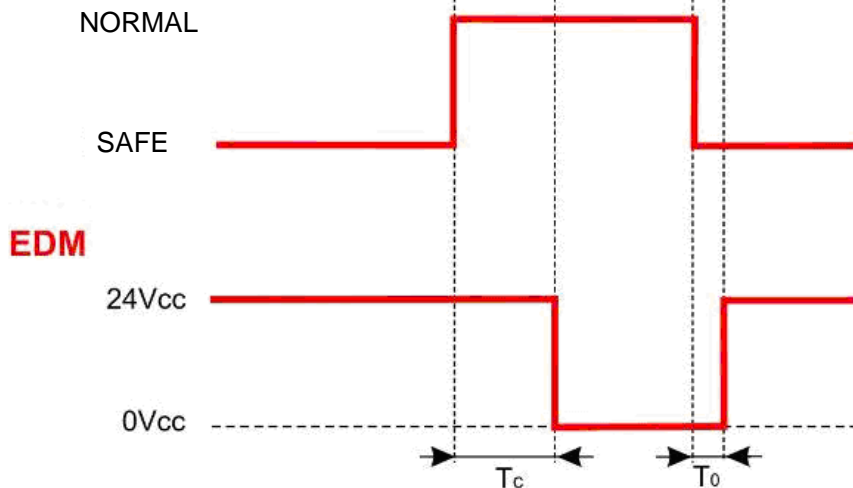
Fig. 17 EDM connections

External devices monitoring (EDM) checks whether the relays (or other control devices) have really opened the power circuit due to a dangerous condition detected by the safety sensors. This function monitors normally closed contacts upon OSSD status change.

EDM function is enabled, terminal 3 is left disconnected (see 4.3 “Complete list of connections”). Activation is confirmed by the decimal point (dot) being displayed on control unit screen.

If EDM is not used, it will be necessary to leave terminal 4 disconnected or consider 0VDC (see 4.3).

OSSDs STATE



- $T_c \geq$ 350 msec: time after SAFCN OFF-ON switch when EDM test is performed.
- $T_o \geq$ 100 msec: time after SAFCN ON-OFF switch when EDM test is performed.

Fig. 18 EDM Timings

To exploit the EDM function available in the SG-BWS-T4 system, you simply have to connect in series the two NC contacts of the external relays, then connect the free ends respectively to 24V and contact 4 of control unit, as shown in the above diagram.

- **Test function**

The Test command temporarily disables beam emission in order to check switching to SAFE status. This function can be activated by opening (for at least 0.5 seconds) an NC outer contact (START/TEST/RESET push-button).

The TEST signal is active low.

When this function is activated, ESPE switches to SAFE status and displays the relevant warning (see section 6 “Diagnostics and warnings”).

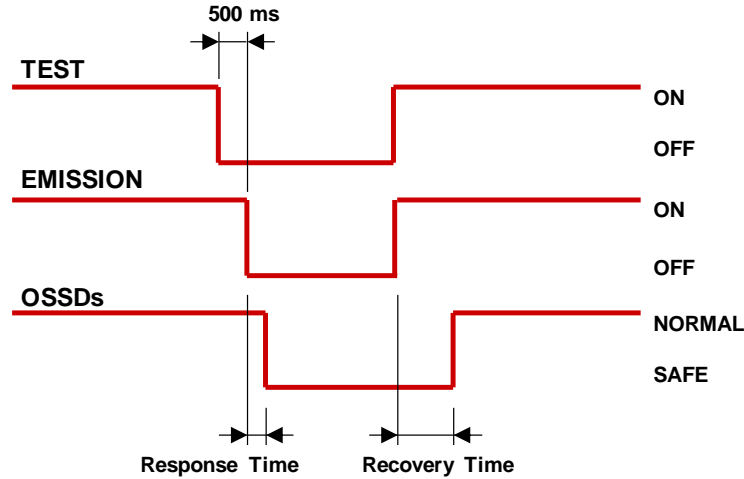


Fig. 20 Test function timings

- **Reset function**

The same push-button can be used to reset the system after a lockout and the relevant error warning. Hold the push-button for **at least 5s** to activate the **reset function**.

If the push-button is held depressed when device is being turned on, the control unit switches to “alignment” mode: please refer to paragraph 5.2 “Safety devices alignment”.

The RESET signal is active low.

5. COMMISSIONING



Before commissioning a system protected by SG-BWS-T4 it shall be inspected and checked by a qualified technician who shall state its suitability. Please refer, for further details on this subject, the instructions given under paragraph 3.1 “Safety information”.

5.1. Screen indications upon switch-on

As soon as control unit is powered, all 7 display segments will turn on. The display will then switch off and all segments are quickly activated one after the other. The display will then switch off again meaning that the device is ready for use. When the display does not switch off, there is an error in the device (see section 6 “Diagnostics and warnings”).

The meaning of displayed values is as follows:

Display	Meaning
	7-segment display test routine. All segments are activated one after the other.
Nothing on screen (only decimal point if EDM on)	The device is ready for use
Any other view	System failure. Refer to section 6 “Diagnostics and warnings”

Tab. 9 Startup visualization sequence

5.2. Safety devices alignment

Once all components are in place and connected, emitters and receivers shall be mutually aligned.

In alignment mode, the SAFCN safety outputs are open. The alignment mode and relevant procedure are described here below:

- **Cut off control unit power supply.**
- **Hold the Test push-button depressed (open Test contact).**
- **Power on the control unit.**
- **The 7-segment display shows the first device to be aligned (Photocells 1-4, light curtains 5-6)**
- **Align the indicated device until display will indicate the following device to be aligned or alignment completed warning (H flashing).**

When alignment is completed, cut off control unit power, release Test push-button (close the contact) and restore control unit power.

The control unit will run the initial test routines and display a countdown, the display will then turn off and the control unit will switch to NORMAL OPERATION status (● NORMAL).

Now carry out the following inspections:

- **The ESPE stays in ●SAFE mode during photocells and light curtains beam interruption using the suitable “Test Piece”, along the entire protected area.**
- **Enabling the TEST function, the SAFCN outputs should open (●SAFE and the controlled machine stops).**
- **The response time upon machine STOP (including response time of the ESPE and of the machine) is within the limits defined for the calculation of the safety distance (see section 3 “Installation”).**
- **The safety distance between the dangerous areas and the safety sensors is in accordance with the instructions included in section 3 “Installation”.**
- **Access of a person between sensors and machine dangerous parts is not possible nor is it possible for him/her to stay there.**
- **Access to the dangerous area of the machine from any unprotected area is not possible.**

During alignment or normal operation, make sure that the photocells connected to the same or other units do not interfere with each other. Should you find interference, change their position, for instance you could set some emitter sets on the side of the other receivers. In case of interference, the control unit will lock out and display the relevant error code.

6. DIAGNOSTICS AND WARNINGS

SG-BWS-T4 is equipped with a user interface featuring 3 LEDs and a 7-segment display.

LED	Indication
● Power	Device is powered correctly
● NORMAL	No danger: safety outputs closed
● SAFE	Danger or fault: safety outputs open
	The 7-segment display shows detailed information on control unit current status

Tab. 10 Signalling interface

6.1. Normal operation signalling

The table below specifies all possible screen indications and the system status or failure associated to each of them.

INDICATION	STATUS	DESCRIPTION	TO DO
<ul style="list-style-type: none"> ● POWER ○ NORMAL ○ SAFE 	Alignment	The display shows the first device to be aligned and then the others in a sequence (1 to 4).	Align the safety devices (see 5.2)
<ul style="list-style-type: none"> ● POWER ○ NORMAL ○ SAFE 	Alignment	All connected devices are aligned	Close the Test contact (Pin 2) and restart the control unit to switch to normal operation (see 5.2)
<ul style="list-style-type: none"> ● POWER ○ NORMAL ● SAFE 	SAFE	The indicated safety device beam is interrupted. If many devices are in this status, the first one is indicated, then the others in a sequence (1 to 4).	Clear the area or check device connections
<ul style="list-style-type: none"> ● POWER ● NORMAL ○ SAFE 	NORMAL OPERATION	The device is in normal operating conditions and monitored area is safe.	
<ul style="list-style-type: none"> ● POWER ●* NORMAL ● SAFE 	Interlock	Waiting for the START command in manual reset mode	Push reset control
<ul style="list-style-type: none"> ● POWER ●/○ NORMAL ○/● SAFE 	NORMAL OPERATION/ SAFE	The decimal point indicates that the EDM function is active (see 4.7)	
<ul style="list-style-type: none"> ● POWER ○ NORMAL ● SAFE 	SAFE	TEST push-button pressed (contact 2 open)	Check TEST push-button connections (see 4.6)

Tab. 11 Normal operation signalling

6.2. Failure state signalling

INDICATION	STATUS	DESCRIPTION	TO DO
<ul style="list-style-type: none"> ○ POWER ○ NORMAL ○ SAFE 	Off	Power disconnected or inner fuse blown due to overload.	Check power supply
<ul style="list-style-type: none"> ● POWER ○ NORMAL ● SAFE 	FAILURE LOCKOUT	It is impossible to determine selected reset mode	Check MAN/AUTO switch connection (terminal 6, see 4.3)
<ul style="list-style-type: none"> ● POWER ○ NORMAL ● SAFE 	FAILURE LOCKOUT	OSSD test routine has failed.	Check OSSD outputs connections (see 4.3). Make sure there is no short-circuit and check the features of the load downstream of the OSSD (see section 9)
<ul style="list-style-type: none"> ● POWER ○ NORMAL ● SAFE 	FAILURE LOCKOUT	EDM test has failed	Check EDM connections (see 4.5) or disable EDM function (see 4.3) if you do not wish to use it.
<ul style="list-style-type: none"> ● POWER ○ NORMAL ● SAFE 	FAILURE LOCKOUT	Start signal time-out tripped.	Make sure you hold the Start button depressed for less than 5s.
<ul style="list-style-type: none"> ● POWER ○ NORMAL ● SAFE 	FAILURE LOCKOUT	One of microprocessor tests has failed	Disconnect power supply and reconnect it. If error persists, please contact the Technical Service.
<ul style="list-style-type: none"> ● POWER ○ NORMAL ● SAFE 	FAILURE LOCKOUT	Test of indicated safety sensor has failed.	Make sure there is no interference across different photocell sets.

Tab. 12 Failure state signalling

9. TECHNICAL DATA

- **SG-BWS-T4**

Electrical data	
Supply voltage:	24 Vdc \pm 15%
Power Consumption:	2.1 W max
Response Time:	SG-BWS-T4: 29 ms SG-BWS-T4-2: 33 ms
Safety category:	Type 4 (ref. EN 61496-1) SIL3 (ref. EN 62061) PL e – Cat. 4 (ref EN ISO 13849-1 2008)
Outputs:	2 PNP
Short-circuit protection:	1.4 A max
Output current:	0.5 A max / each output
Output voltage – status ON:	Vdd –1 V min
Output voltage – status OFF:	0.2 V max
Capacitive load:	2.2 μ F @ 24Vdc max
Cables length (for power supply):	50 m. max
Pollution rating:	2
Mechanical and environmental data	
Operating temperature:	0...55°C
Storage temperature:	-25...+ 70 °C
Temperature rating:	T6
Humidity:	15...95 % (no condensation)
Mechanical protection:	IP 20 (EN 60529)
Vibrations:	Width 0.35 mm, frequency 10 ... 55Hz; 20 sweep per axis, 1octave/min (EN 60068-2-6)
Shock resistance:	16 ms (10 G) 1,000 shocks per axis (EN 60068-2-29)
Housing material:	Nylon PA66
Weight:	125 g

Tab. 13 SG-BWS-T4 technical data