

<b>ROBOPAC</b> Norm. Tech. 60.2.60_00	<b>TECHNICAL DOCUMENTATION</b> - ECOWRAP / ECOWRAP XL -	<b>Date:</b> <b>July 2018</b>	<b>Rev.03</b>
	ENGLISH	<b>PAGE 1 / 26</b>	

# TECHNICAL DOCUMENTATION

## - ECOWRAP



Date	Revisions	Revisions reasons	Issued by	Checked by	Approved by
10/09/2013	00	General revision	<i>Saravelli D.</i>	<i>Saravelli D.</i>	<i>Saravelli D.</i>
09/05/2017	01	General revision	<i>Baldinini F.</i>	<i>Baldinini F.</i>	<i>Baldinini F.</i>
18/09/2017	02	Pallet photocell regulation	<i>Baldinini F.</i>	<i>Baldinini F.</i>	<i>Baldinini F.</i>
10/07/2018	03	Index realization	<i>Baldinini F.</i>	<i>Baldinini F.</i>	<i>Baldinini F.</i>

 <b>Norm. Tech.</b> <b>60.2.60_00</b>	<b>TECHNICAL DOCUMENTATION</b> <b>- ECOWRAP / ECOWRAP XL -</b>	<b>Date:</b> <b>July 2018</b>	<b>Rev.03</b>
	<b>ENGLISH</b>	<b>PAGE 2 / 26</b>	

## Index

SPOOL CARRIAGE SKETCH DETAIL ECOWRAP.....	4
OPERATOR PANEL DESCRIPTION .....	5
PACKING SETTING PARAMETERS RANGE.....	6
FILM DATA.....	6
KEYBOARD LOCK FUNCTION.....	6
MANUAL OPERATIONS FOR ARM ROTATION AND FOR SPOOL CARRIAGE .....	7
RE-INFORCEMENT WRAPS SETTING.....	7
PROCEDURE TO INSTALL THE SOFTWARE ECOWRAP.....	8
INTERNAL PARAMETER SETTING PROCEDURE AND INTERNAL PARAMETER ECOWRAP .....	9
INTERNAL PARAMETER RESETING TO DEFAULT VALUES .....	9
OPERATOR PANEL CARD DETAIL ECOWRAP .....	10
ELECTRIC BOX DETAIL ECOWRAP.....	11

 <b>Norm. Tech.</b> <b>60.2.60_00</b>	<b>TECHNICAL DOCUMENTATION</b> <b>- ECOWRAP / ECOWRAP XL -</b>	<b>Date:</b> <b>July 2018</b>	<b>Rev.03</b>
	<b>ENGLISH</b>	<b>PAGE 3 / 26</b>	

DESCRIPTION LIST FOR “LED” (INPUT / OUTPUT) ON MAIN BOARD START\_02 ECOPAT ECOWRAP ..... 12

EXPASION CARD P&P03 DETAIL AND I/O DESCRIPTION ECOWRAP ..... 13

ELECTRICAL AND MECHANICAL SETTINGS ON ECOWRAP ..... 14

    UP-WARD AND DOWN-WARD MECHANICAL SWITCH TO LIMIT THE CARRIAGE MOVEMENT ..... 14

    DEVICES EQUIPPED ON ECOWRAP’S PE SPOOL CARRIAGE ..... 15

    CHAIN TENSION ADJUSTMENT ..... 16

PRODUCT HEIGHT DETECTION PHOTOCCELL CALIBRATION ..... 19

    Standard photocell (for clear products) ..... 19

    Dark product photocell ..... 19

    Photocell for black products S65 ..... 20

ALARM LIST AND TROUBLESHOOTING ECOWRAP ..... 21

ALARM LIST AND CONDITION OF STATUSI/ALARMS ECOWRAP ..... 25

**SPOOL CARRIAGE SKETCH DETAIL ECOWRAP**

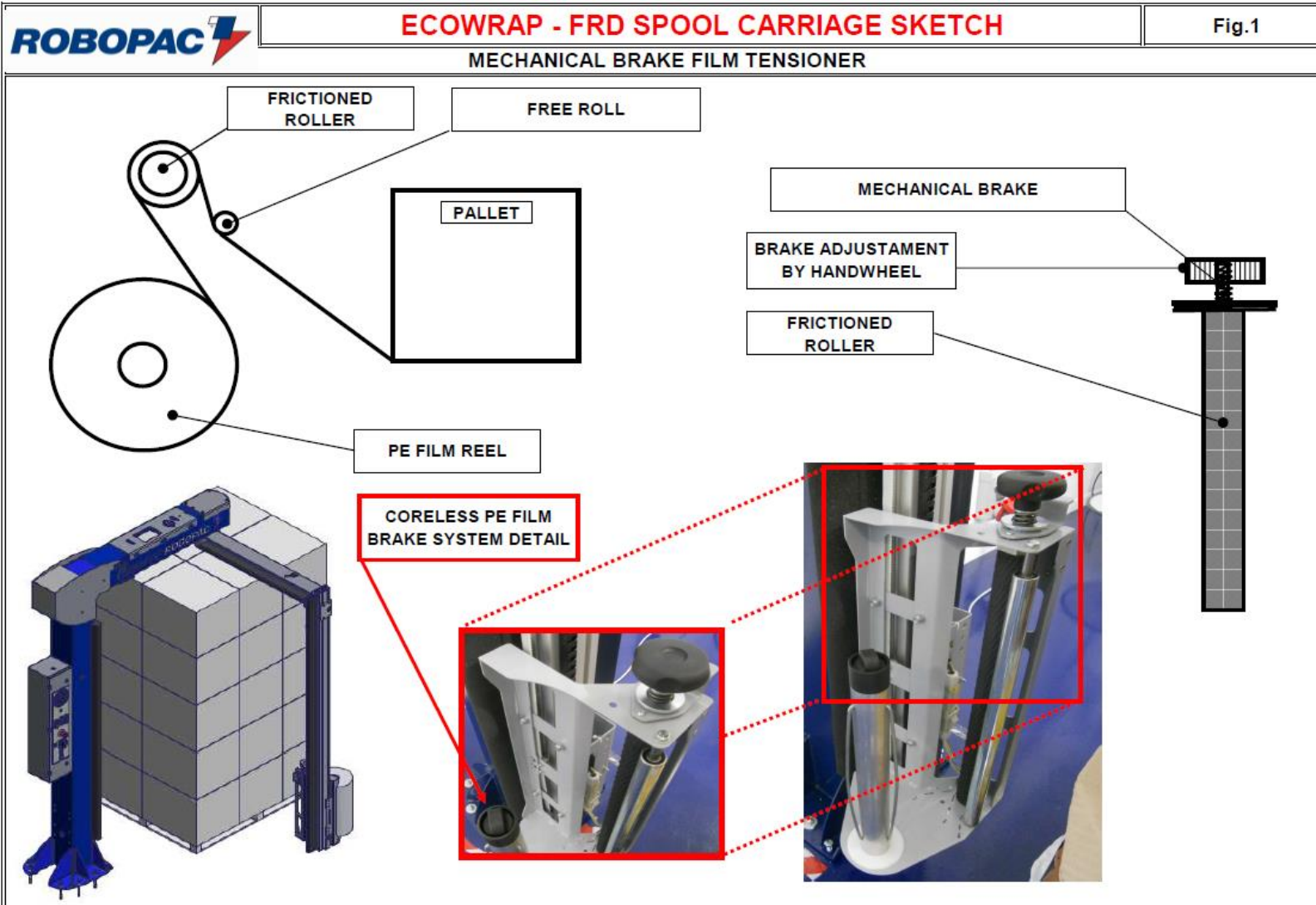

















**OPERATOR PANEL DESCRIPTION**



Push button / multi-function selector JOG

**Flg.2**

	Detection product photocell delay setting
	Up / Down packing cycle selection
	Only one direction packing cycle selection
	Spool carriage position setting after packing cycle complete
	Spool carriage Up / Down speed setting
	Top over wraps setting
	Spool carriage manuals movements
	Bottom over wraps setting
	Arm rotation speed setting
	START push button
	Main switch for machine's ON / OFF
	RESET push button
	STOP push button
	EMERGENCY push button
	Manual push bitton for un-lock fo rotation Arm's motor break

 <b>Norm. Tech.</b> <b>60.2.60_00</b>	<b>TECHNICAL DOCUMENTATION</b> <b>- ECOWRAP / ECOWRAP XL -</b>	<b>Date:</b> <b>July 2018</b>	<b>Rev.03</b>
	<b>ENGLISH</b>	<b>PAGE 6 / 26</b>	

## PACKING SETTING PARAMETERS RANGE



Parameter	Min. – Max.	Step	Measure unit
Bottom over wraps	0 – 10	1	Rounds
Top over wraps	0 – 10	1	Rounds
Over wraps rounds	1 – 5	1	Rounds
Product detection photocell delay time	0 – 40	1	Cmss
Arm rotation speed	7 – 11	1	Rpm
Up-ward spool carriage speed	2,6 – 6,0	0.2	mt/minute
Down-ward spool carriage speed	2,6 – 6,0	0.2	mt/minute
Spool carriage position after packing cycle complete	0 – 150	10	Cms

### FRD SPOOL CARRIAGE

Parameter	Min. – Max.	Step	Measure unit
Film stretch (mechanical)	--	--	--

## FILM DATA





















To see the DATA FILM menu, turn ON the machine keeping the “JOG ” push button pressed.

When the display will show the indication ‘DAT’, release the “JOG ” button. Rotating the “JOG ” it is possible to scroll-down the values list shown in the below table. The new value will be memorized as soon the machine will be turned OFF and the related value on P4 of the internal parameters as well. To reset the partial counter, it is necessary to press the “JOG ” button for 4 seconds at least.

<b>D1</b>	Partial packing cycle counter (0-999) re-settable	<b>D5</b>	V on bus DC (volt)
<b>D2</b>	Total packing cycle counter (thousand)	<b>D6</b>	Electronic card temperature (°C)
<b>D3</b>	Total packing cycle counter (units – not reseptable)	<b>D7</b>	Free
<b>D4</b>	Free		

## KEYBOARD LOCK FUNCTION

It is possible to lock the keyboard of the machine following the next procedure:

1. Turn the machine ON.
2. Rotate the “JOG ” till get on the command “Top over wraps setting ”, the related led must light ON.
3. Press for about 5 seconds the “JOG ” till get on the display the message “FrE”.
4. Rotate the “JOG ” clockwise direction for 6 steps (the leds on the next commands must light ON “ -  -  -  - ”).
5. Rotate the “JOG ” counter clockwise direction for 5 steps (the leds on the next commands must light OFF “ -  -  -  - ”).
6. Rotate the “JOG ” clockwise direction for 5 steps (the leds on the next commands must light ON “ -  -  - ”).
7. Press the “JOG ” till the get on the display of the machine the message “LoC”.

When the operator panel is locked, it is possible to press the push buttons of “RESET”, “START”, “STOP”, “ROTATION BREAK UNLOCK” & “EMERGENCY”, and gives E70 message trying to change any of the packing settings.





8. To unlock the operator panel, repeat the same procedure above (steps from 1 to 7) till get the message on the display “FrE”.

 <b>Norm. Tech.</b> <b>60.2.60_00</b>	<b>TECHNICAL DOCUMENTATION</b> <b>- ECOWRAP / ECOWRAP XL -</b>	<b>Date:</b> <b>July 2018</b>	<b>Rev.03</b>
	<b>ENGLISH</b>	<b>PAGE 7 / 26</b>	

## MANUAL OPERATIONS FOR ARM ROTATION AND FOR SPOOL CARRIAGE





### 6.1. Rotation arm manual movements

To manually run the rotation for the arm of the machine proceed as follows:

1. Rotate the "JOG " push button till get the position of the command "Arm rotation speed setting ".
2. Keep pressed the "JOG " push button for 2 seconds approx. till get on the machine's display the message "Ret" and the rotation arm start to move till reaching the phase position. To stop the rotation arm, press the button "STOP ".
3. Upon a machine's "stop" of the arm rotation, to re-start it is necessary to press the "JOG " push button for about 2 seconds.

### 6.2. PE film spool carriage manual movements









To manually run the up-ward and down-ward PE film spool carriage movement, proceed as follows:

1. Rotate the "JOG " push button till get the position of the command "Spool carriage manual movements ".
2. Press the "JOG " push button to enable the manual function.
3. Rotate the "JOG " push button in the required direction for the necessary time to perform the desired movement (movement with operator's presence).

## RE-INFORCEMENT WRAPS SETTING

It is possible to make re-inforcement wraps to the product during the up-ward movement of the spool carriage, to make the packing stronger and more stable.

It is necessary to follow the next procedure step by step:

- A. Run a packing cycle by pressing the "Start " push button. During PE film spool carriage movement, upon being sure that the "JOG " is set to the function "Spool carriage manual movements ", keeping pressed the "JOG " push button, the carriage will stop its up-ward movement, applying the PE film in the same position till the "JOG " will become released, allowing the carriage to re-start its up-ward running (re-inforcement wraps with operator presence).
- B. Run a packing cycle by pressing the "Start " push button. During PE film spool carriage movement, upon being sure that the "JOG " is set to the function "Spool carriage manual movements ", press few times the "JOG " push button for the number of re-inforcement wraps desired, the carriage will stop its up-ward movement applying the PE film in the same position for the number of wraps set (re-inforcement wraps without operator presence with wraps countdown).

## PROCEDURE TO INSTALL THE SOFTWARE ECOWRAP

The START\_02 Mother-board equipped on Ecowrap machines, get the machine's software implemented into the electronic card.

To install the machine's software into the Mother-board START\_02 it is necessary to follow the next procedure:

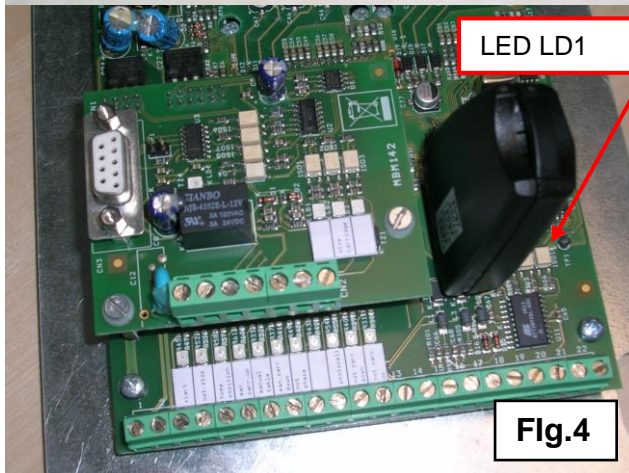
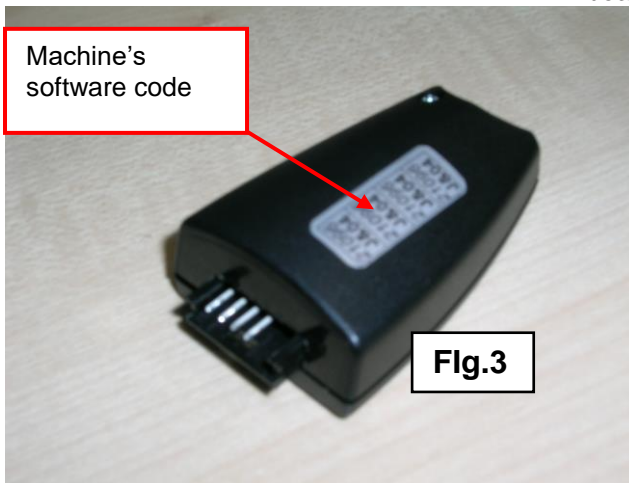

1. Turn the machine OFF (START02 mother-board not fed and capacitor completely discharged).
2. Insert the program KEY-PRG02 (fig.6) indicating the appropriate code of the software into the connector CN4 equipped on START02 mother-board (fig.7)
3. Turn the machine ON and check that the led **LD1** mounted on the START\_02 mother-board (fig.7) make the following blinking sequence:
  - **ON** for about **3 seconds** (*insertion key checking phase*).
  - OFF for about 0.5 seconds.
  - **ON** for about **8 seconds** (*microcontroller master memory flash deleting pahse*).
  - OFF for about 0.5 seconds.
  - **ON** for about **28 seconds** (*EEPROM reading and microcontroller master writing pahser*).
  - Definitely OFF (download completed)
4. Turn the machine OFF and wait that all the LEDS on the mother-board are completely OFF (*capacitor discharged*).
5. Extract the KEY-PRG02 from the socket CN4 on the PLC electronic card START02 to complete the machine's software installation and run the machine for packaging.

 <b>Norm. Tech.</b> <b>60.2.60_00</b>	<b>TECHNICAL DOCUMENTATION</b> <b>- ECOWRAP / ECOWRAP XL -</b>	<b>Date:</b> <b>July 2018</b>	<b>Rev.03</b>
	<b>ENGLISH</b>	<b>PAGE 9 / 26</b>	

## INTERNAL PARAMETER SETTING PROCEDURE AND INTERNAL PARAMETER ECOWRAP

To access and modify the internal parameter of the machine proceed like following:

1. Turn the machine OFF
2. Move the deep switch SW1,1 of the display card (Fig.8) in position ON
3. Turn the machine ON (the display will shows parameter P1 alternatively to its set value)
4. To scroll-down the parameters, press the encoder "JOG" push button
5. To modify the visualized parameter, rotate the "JOG" button
6. When the operation is completed, move again the deep switch SW1,1 in its OFF original position (working cycle mode).
7. Turn the machine OFF to exit from the internal parameter setting mode and run the machine for packing.

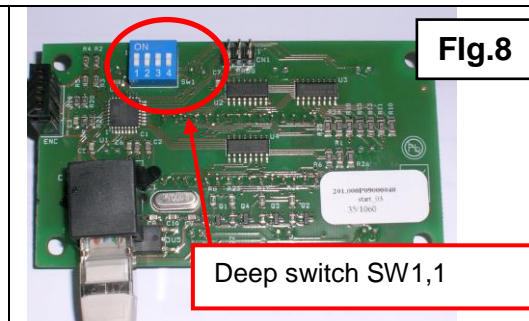

Parameter	Range	Default (producer values)	Parameter description	Set value on machine's end- user
P1	--	--	Free	
P2	--	--	Free	
P3	0 - 1	0	Enable for motors current consumption test for arm rotation motor and up-ward / down-ward spool carriage	
P4	--	--	Free	
P5	--	--	Free	
P6	--	--	Free	
P7	--	--	Free	
P8	--	--	Free	
P9	0 - 255	0	FOR ROBOPAC USES ONLY	
P10	0 - 1	0	Enable for film data RESET	

## INTERNAL PARAMETER RESETTING TO DEFAULT VALUES

It is suggestible to reset the internal parameter values to producer default every time that will be necessary to replace the software on the machine, and then, re-set the suitable internal parameter according the machine configuration.

1. Scroll-down the internal parameter till reaching the parameter P10
2. Keep pressed the encoder "JOG" push button till will be shown on the display of the machine the message 'DEF'
3. Release the "JOG" button

**If during the DEFAULT operation, if the internal parameter P10=1, the packing partial cycle counters (only) will be reset too.**

**OPERATOR PANEL CARD DETAIL ECOWRAP**

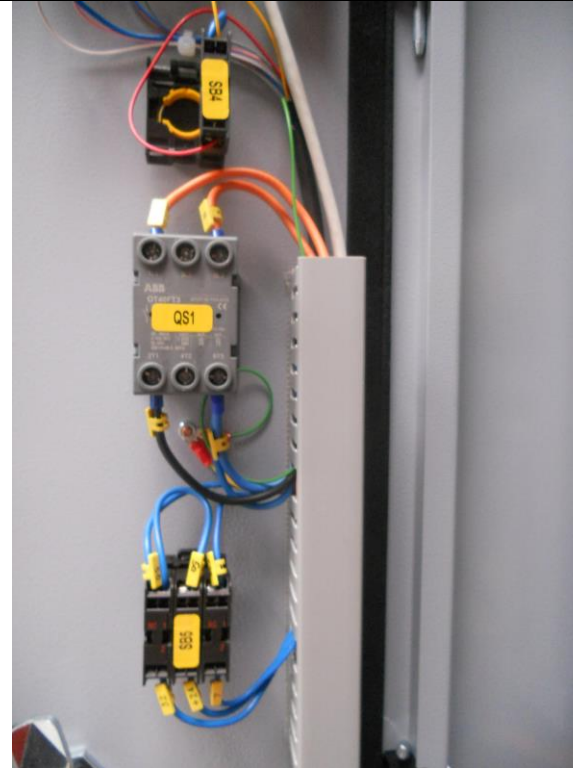
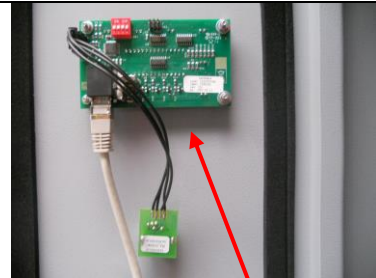

Display card detail code 1430300164

JOG card detail code 143030125

**ELECTRIC BOX DETAIL ECOWRAP**

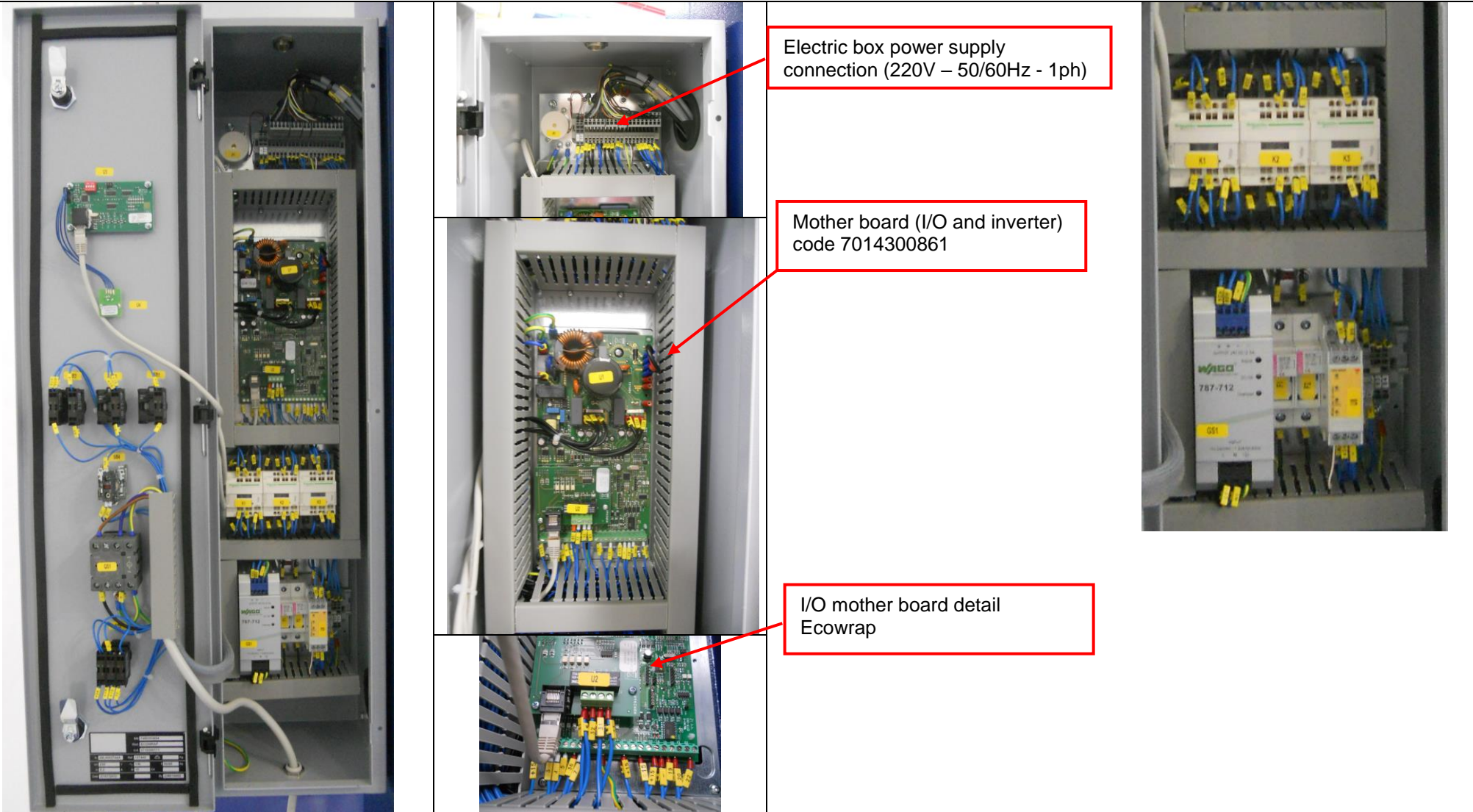

**DESCRIPTION LIST FOR "LED" (INPUT / OUTPUT) ON MAIN BOARD START 02 ECOPAT ECOWRAP**

**Fig.6**

- Ground for plate
- Alimentazione scheda
- K2 relay & sticker identification machine software
- Serial port connector for keypad programmer
- Input Main connector
- Output Inverter pre-stretch
- Up-ward / down-ward spool
- P&P03 expansion card code 1430300170
- LED (LD1) Diagnostics & software
- CN4 CONNETTOR (to download machine's software)

When it is necessary to install/replace the mother.-board START\_02 into the electric box of the ECOWRAP machine, upon its mechanical correct monting and ist appropriate wiring, it is necessar to check that the bridges shown on the above picture are present on the card, otherwise, provide accordingly.

To dismantle the START\_02 mother-board from machine's electric box, unwire it from behind firstly, and then, take it out from the back side, after dismantled the close plate, as shown in the above pictues

**EXPASION CARD P&P03 DETAIL AND I/O DESCRIPTION ECOWRAP**

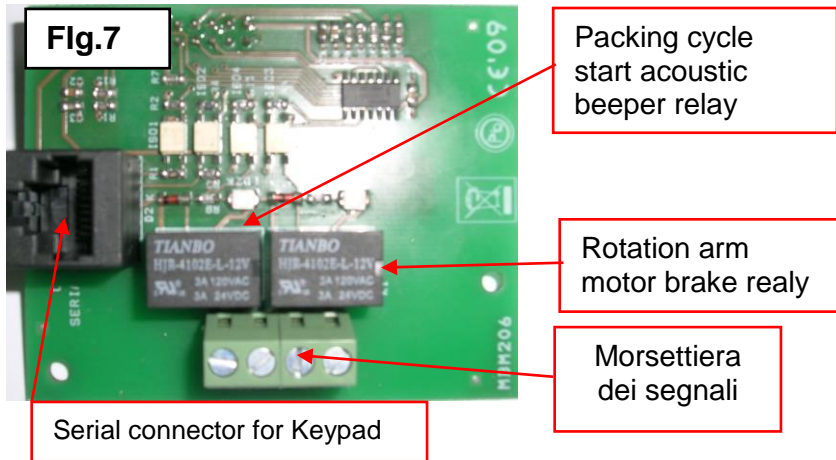

**Output description P&P03 expansion card**

Led #	Led description	Led status
LD1	Output led for acoustic (beeper)	Beeper output enabled = led ON
LD2	Output led for motor brake	Brake output enabled = led ON

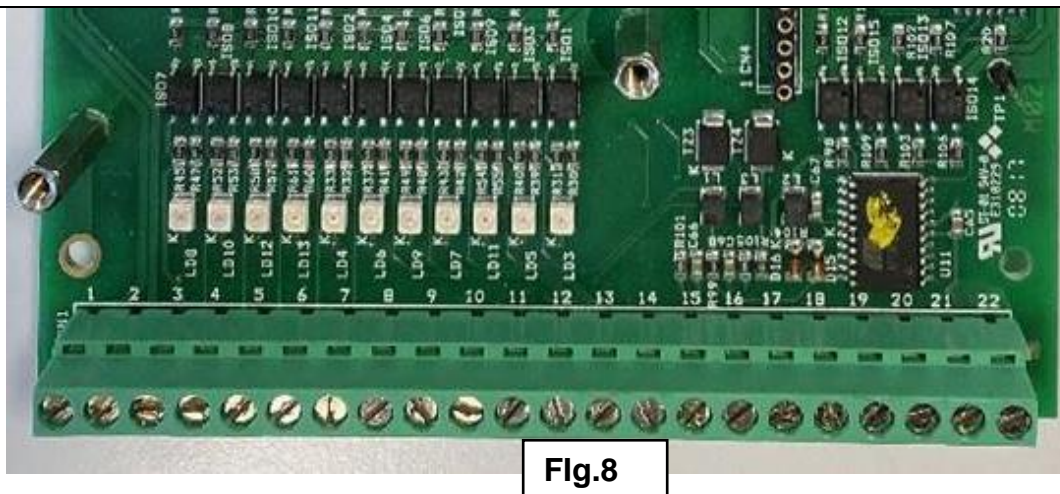

**Input description START\_02 Mother-board**

Led #	Led description (from left to right on Fig.8)	Led status
LD8	Reset	Push button pressed = led ON
LD10	Stop	Push button pressed = led OFF
LD12	Start	Push button pressed = led ON
LD13	Emergency (safety module disconnected)	Emergency activated = led OFF
LD4	Brake un-lock	Push button pressed = led ON
LD6	Free	
LD9	Rotating arm mechanical switch	Rotating arm in phase position = led OFF
LD7	Free	
LD11	Product detection photocell	Detected product = led ON
LD5	Bottom carriage switch	Carriage in bottom position = led OFF
LD3	Top carriage switch	Carriage in top position = led OFF

**ELECTRICAL AND MECHANICAL SETTINGS ON ECOWRAP****UP-WARD AND DOWN-WARD MECHANICAL SWITCH TO LIMIT THE CARRIAGE MOVEMENT**

The pictures on the side, shown the top and bottom position cam and the mechanical switch which limit the movement of the PE film spool carriage for top and bottom high.

**DEVICES EQUIPPED ON ECOWRAP'S PE SPOOL CARRIAGE**

The picture on the side shown the fast connector for the easy mounting and electrical wiring of the PE film spool carriage



The picture on the side, shown the product detection photocell which detect the high shape of the product. The photocell is equipped of a trimmer to adjust the sensitivity (detection distance).

<b>ROBOPAC</b> Norm. Tech. 60.2.60_00	<b>TECHNICAL DOCUMENTATION</b> - ECOWRAP / ECOWRAP XL -	Date: July 2018	Rev.03
	ENGLISH	PAGE 16 / 26	

## CHAIN TENSION ADJUSTMENT

The rotation chain must have a contained free movement in order to limit the freedom of movement of the rotating arm when the brake is operating.

To verify the correct tension of the arm rotation chain, proceed as follows:

- Make sure the machine is switched off, with the rotating arm stationary
- Place a long strip of paper scotch approximately 250 mm around the fixed mast on the opposite side of the control panel, about 1.5 m high.



<b>ROBOPAC</b> Norm. Tech. 60.2.60_00	<b>TECHNICAL DOCUMENTATION</b> - ECOWRAP / ECOWRAP XL -	Date: July 2018	Rev.03
	ENGLISH	PAGE 17 / 26	

- Go to the side of the rotating arm where the carriage is fixed
- Place a marker on the aluminum profile on the carriage mounting side, at the height of the previously placed scotch strip



Pull the rotating arm, turning it counter-clockwise to the normal working direction, until the end of stroke and keeping it in tension. Be careful not to exceed by force.

- While holding the marker resting on the profile, make a vertical stroke on the scotch strip.
- Push the rotating arm, turning it in the normal working direction, until possible end and keep it in tension. Be careful not to exceed by force.
- While holding the marker resting on the profile, make a vertical stroke on the scotch strip.
- Measure with the meter the distance between the two markers drawn on the scotch.

<b>ROBOPAC</b> Norm. Tech. 60.2.60_00	<b>TECHNICAL DOCUMENTATION</b> - ECOWRAP / ECOWRAP XL -	Date: July 2018	Rev.03
	ENGLISH	PAGE 18 / 26	

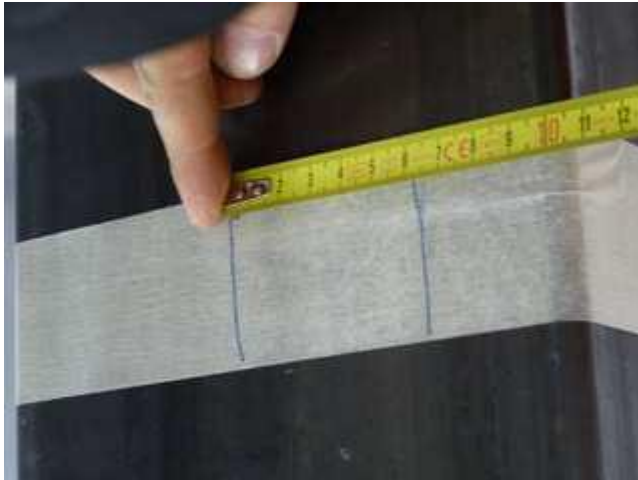

- The distance between the two should be 45mm +/- 15mm
- If the distance does not fall within the required values, you must adjust the chain again.  
Do as follows:
- Loosen the 6 mounting screws on the motor support plate, located on the sides of the fixed arm.
  - If the previously detected free movement was excessive, tighten the free movement adjustment screw set to above the fixed arm.
  - If the free movement was too low, loosen the free movement screw above the fixed arm and adjust the sheet to the screw itself.
  - Tighten the 6 mounting screws on the motor support plate.
  - Re-test the correct tension check described at the top of the page.

## PRODUCT HEIGHT DETECTION PHOTOCELL CALIBRATION

### Standard photocell (for clear products)

Adjust the photocell sensitivity trimmer to load centre



### Dark product photocell

#### Suppression distance setting

##### 1. Object detection

Position object to detect in front of the sensor at the distance required.  
Turn distance adjustment trimmer (ADJ) to minimum: yellow LED OFF and green LED ON.



Rotate trimmer in a clockwise direction until the yellow LED and green LED turn ON. Object detection condition (A status of position indicator)



A

##### 2. Background suppression

Remove object and ensure that the background is in front of the sensor: yellow LED OFF and green LED ON.



Rotate trimmer in a clockwise direction until the yellow LED and green LED turn ON: background detection condition (B status of position indicator).



B

The trimmer reaches maximum level with yellow LED OFF if the background is outside the operating range.

Rotate trimmer in an anticlockwise direction until yellow LED turns OFF and green LED ON: condition where background is outside operating range (C status of position indicator).



C

##### 3. Setting and control

Rotate trimmer in an anticlockwise direction until the indicator reaches an intermediate point between position A and C.



If position A and C are close to each other, leave trimmer on position C. The sensor is now ready to function correctly and in stable conditions:



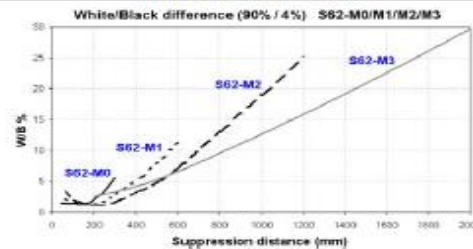

#### DETECTION DIAGRAM

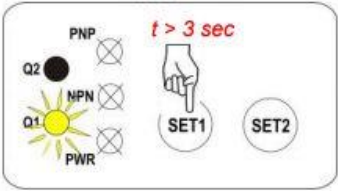

 <b>Norm. Tech.</b> <b>60.2.60_00</b>	<b>TECHNICAL DOCUMENTATION</b> - ECOWRAP / ECOWRAP XL -	<b>Date:</b> <b>July 2018</b>	<b>Rev.03</b>
	ENGLISH	<b>PAGE 20 / 26</b>	

### Photocell for black products S65

	Place the target at the center of the pallet
<p style="text-align: center;"><b>Teach-In</b></p> 	Keep pressed the Set1 button for more than 3 seconds, till led Q1 flashing
	Release the button, target detected

 <b>Norm. Tech.</b> <b>60.2.60_00</b>	<b>TECHNICAL DOCUMENTATION</b> <b>- ECOWRAP / ECOWRAP XL -</b>	<b>Date:</b> <b>July 2018</b>	<b>Rev.03</b>
	<b>ENGLISH</b>	<b>PAGE 21 / 26</b>	

## ALARM LIST AND TROUBLESHOOTING ECOWRAP

Alarm code	Alarm description	Troubleshooting	Cause of the fault	Solution
<b>E01</b>	Emergency push button pressed, or safety bumper crash	Check the electrical contact of the emergency push button	The electrical contact is damaged or the wiring is interrupted	Replaced the electric contact or restore the electrical wiring
		Check that safety bumper works properly	The safety bumper is mechanical damaged or electrically interrupted	Replaced the safety bumper or restore the electrical wiring
		Check the appropriate functioning of the safety module U8	Safety module is defective	Replace safety module.
<b>E10</b>	Traspallet photocell alarm (actually not working - disabled).			
<b>E30</b>	Rotation arm inverter comand overload	Disconnect motor rotation arm from the mother-board and start a packing cycle.	If the alarm message disappears there is a fault of the rotation arm motor	Replace rotation arm motor
			If the alarm message doesn't disappears, there is a fault on the mother-board.	Replace mother-board.
		Check the gearbox connected to the rotation arm motor	Possible fault of the gearbox	Replace the gearbox
<b>E31</b>	Up-ward / down-ward spool carriage inverter alarm	Disconnect the up-ward / down-ward spool carriage motor from the mother-board and start a packing cycle.	If the alarm message disappears there is a fault of the up-ward / down-ward spool carriage motor	Replace up-ward / down-ward spool carriage motor
			If the alarm message doesn't disappears, there is a fault on the mother-board.	Replace mother-board.
		Check the gearbox connected to the up-ward / down-ward spool carriage motor	Possible fault of the gearbox	Replace the gearbox

<b>E34</b>	Inverter overtemperature alarm	Check that a mechanical impediment obstruct the appropriate machine's working	A mechanical impediment gives the alarm message	Remove the mechanical obstacle and start the cycle
		Disconnect all the motors from the mother-board and play a cycle	If the alarm message doesn't disappears, there is a fault on the mother-board.	Replace mother-board.
			If the alarm message disappears there is a fault of one of the motors or gearboxes	Replace motor or gearboxes in fault
<b>E41</b>	Serial communication error	Check the phone cable which connect expansion card and display card	Phone cable defective	Replace phone-cable
		Check the conditions of the connectors for phone-cable on expansion card and display card	The connector on one of the two cards is defected	Replace the defected card.
		Check the connector between mother-board and expansion card	The connector is open	Plug the connector properly
		Check the expansion card and mother-board working	Defect on mother-board or expansion card	Replace the defected card
<b>E42</b>	Missing cycle parameters list initialization		Installation of the operator panel display card or machine's software not completed	Make the initialization procedure as indicared in paragraph 9 and 10.
<b>E43</b>	Data flash not writable	Check the wiring conditions of all card	Defect on mother-board	Replace mother-board card.
<b>E44</b>	Csum data flash non correct	Check the wiring conditions of all card	Defect on mother-board	Replace mother-board card.
<b>E46</b>	Communication error between rotation arm inverter's micro and carriage (signal from arm micro/sensor)	Check the wiring conditions of all card	Connection cable defected	Replace cable.
			Defect on mother-board	Replace mother-board card.
<b>E47</b>	Communication error between turntable inverter's micro and carriage (signal from carriage micro)	Check the wiring conditions of all card	Connection cable defected	Replace cable.
			Defect on mother-board	Replace mother-board card.



Norm. Tech.  
60.2.60\_00

**TECHNICAL DOCUMENTATION**  
- ECOWRAP / ECOWRAP XL -

Date:  
July 2018

Rev.03

ENGLISH

PAGE 23 / 26

<b>E61</b>	Blocked rotation arm alarm	Check the tension of the rotation arm chain	Chain not appropriate tensioned or possible break of the chain	Properly tension the chain or replace it in case it is break.
		Check rotation arm motor	Motor damaged	Replate rotation arm motor.
		Check rotation arm gearbox	Gearbox damaged	Replate rotation arm gearbox.
		Check the position of the mechanical switch/sensor compared to its cam	Wrong positioning of the mechanical switch/sensor	Fit the mechanical switch/sensor in the appropriate position.
		Check that the mechanical switch/sensor is working properly	Damage of the mechanical switch/sensor or related wiring	Replace the mechanical switch/sensor
		Check that input (DL9) on the mother-board card works properly	Possible fault on the mother-board card.	Replace mother-board card
<b>E62</b>	Blocked PE film spool carriage alarm	Check the tension of the lifting spool carriage belt	Belt not appropriate tensioned or possible break of the belt	Properly tension the belt or replace it in case it is break.
		Check lifting carriage motor	Motor damaged	Replate lifting carriage motor
		Check lifting carriage gearbox	Gearbox damaged	Replate lifting carriage gearbox
		Check the position of the mechanical switch compared to its cam	Wrong positioning of the mechanical switch	Fit the mechanical switch in the appropriate position.
		Check the appropriate working of the top and bottom position mechanical switch	Possible fault of the mechanical switch (top position or bottom position) or related wiring	Replace the defected mechanical switch or restore its wiring.
		Check the inputs (DL5 or DL3) on the mother-board	Possible fault of the mother-board	Replace mother-board card.
<b>E70</b>	Function not active information	Option not active		
		Operator panel display locking activated		Unlock the operator panel as indicated in paragraph 5.
		Check the control operator panel display card and mother-board card.	Possible fault of one of the two cards.	Replace mother-board card or operator panel display card.

 <b>Norm. Tech.</b> <b>60.2.60_00</b>	<b>TECHNICAL DOCUMENTATION</b> <b>- ECOWRAP / ECOWRAP XL -</b>	<b>Date:</b> <b>July 2018</b>	<b>Rev.03</b>
	<b>ENGLISH</b>	<b>PAGE 24 / 26</b>	

<b>E90</b>	Low power supply voltage alarm	Check the power supply that must be according the machine's specifications	The power supply isn't according the technical specification.	Adjust the power supply according the specification
			The mother-board card is defected	Replaced mother-board card
<b>E91</b>	High power supply voltage alarm	Check the power supply that must be according the machine's specifications	The power supply isn't according the technical specification.	Adjust the power supply according the specification
			The mother-board card is defected	Replaced mother-board card
The carriage does not move (not going up and not going down)		Check bottom and top micro switches	One or both are damaged.	Replace the / both damaged microswitches
		Check that the bottom and top microswitches send correct signal to the main board	Top / bottom microswitches electrical fault possible or incorrect electrical wiring	If the electrical wiring of the wiring is compromised, it must be restored, and if the problem is related to the mechanical limit switches, it will be necessary to replace them
		Check the working conditions of the main board	The main board could be damaged	If the main board receives signals from the mechanical limit switches properly, the card is faulty and must be replaced.
The film broken during the packing of it is not properly applied to the pallet (too light or too tight)		Check that the film is running through the last dancing roller of the spool carriage (where it is connected the sensitivity sensor – load cell)	Wrong film insertion onto the spool carriage.	Insert the film on the spool carriage in the proper way following the instructions in the user manual.

 <b>Norm. Tech.</b> <b>60.2.60_00</b>	<b>TECHNICAL DOCUMENTATION</b> <b>- ECOWRAP / ECOWRAP XL -</b>	<b>Date:</b> <b>July 2018</b>	<b>Rev.03</b>
	<b>ENGLISH</b>	<b>PAGE 25 / 26</b>	

## ALARM LIST AND CONDITION OF STATUS/ALARMS ECOWRAP

The START02 PLC card got an LED for feeding / diagnostic signals (please refer to led "LD1" fig.6) that according the number of blinking gives information about the status of the machine, possible faults and protection alarms

Blinkings led LD1	State/Alarm	State/alarm description	Solution
1	Stop mode	Machine waiting for the START input	Press START push button
2	Machine in RUN	Machine working in automatic mode	-----
3	Arm rotation motor current alarm	Hardware alarm because of a current peak like a shortcut.	Check that there isn't a mechanical impediment of the arm rotation. Disconnect the arm rotation motor by mother-board side and play a packing cycle (START). If the problem persists replace the mother-board, otherwise replace the arm rotation motor.
4	Rotation arm motor overload	Alarm on the current average absorbed	Check that there isn't a mechanical impediment of the rotation arm. Disconnect the arm rotation motor from the mother-board and play a packing cycle (START). If the problem persists replace the mother-board, otherwise replace the arm rotation motor.
5	Over voltage alarm	Alarm for voltage too high (above than 276VAC i.e. 390VDC)	Carefully check the power supply of the facility connected to the machine. If the power supply is according the technical specification, replace the mother-board of the machine.
6	Low voltage alarm	Alarm for voltage too low (below than 183VAC i.e. 190VDC)	Carefully check the power supply of the facility connected to the machine. If the power supply is according the technical specification, replace the mother-board of the machine.
7	Temperature alarm	Temperature alarm. The card reached the maximum limit acceptable of temperature during the working status. The temperature near the power module is higher than 85°C.	Turn the machine OFF for few minutes to cool it. Then turn it ON again. If the problem persists, replace the mother-board.
8	Communication alarm	Communication fault between the microcontroller master & microcontroller slave.	Check the electrical continuity of the wiring/connections. In case, replace the mother-board.
9	Up-ward / down-ward spool carriage motor current alarm	Hardware alarm because of a current peak like a shortcut.	Check that there isn't a mechanical impediment of the spool carriage up/down movement. Disconnect the turntable rotation motor and play a packing cycle (START). If the problem persists replace the mother-board, otherwise replace the turntable motor.

 <b>Norm. Tech.</b> <b>60.2.60_00</b>	<b>TECHNICAL DOCUMENTATION</b> <b>- ECOWRAP / ECOWRAP XL -</b>	<b>Date:</b> <b>July 2018</b>	<b>Rev.03</b>
	<b>ENGLISH</b>	<b>PAGE 26 / 26</b>	

<b>10</b>	Up-ward / down-ward spool carriage motor overload	Alarm on the current average absorbed	Check that there isn't a mechanical impediment of the spool carriage up/down movement. Disconnect the turntable rotation motor and play a packing cycle (START). If the problem persists replace the mother-board, otherwise replace the turntable motor.
<b>11</b>	Communication alarm	Communication alarm indicated by I microcontroller slave (only for producer use).	Contact Robopac's after sales service dpt.
<b>12</b>	Tiny alarm	Tiny program alarm, analogical inputs (only for producer use).	Contact Robopac's after sales service dpt.
<b>13</b>	Initialization phase	(only for producer use).	Contact Robopac's after sales service dpt.
<b>14</b>	Rotating arm phase position alarm	Missing signal from phase limit switch/sensor during turntable rotation	Check that the mechanical switch/sensor gives the appropriate signal to the mother-board (led LD9). If the signal doesn't arrive, check the mechanical switch/sensor position and working conditions and its wiring too. If the signal arrive to the mother-board, replace it (defect on input connector).